

CONDUCTOR™ W4

Technical Manual

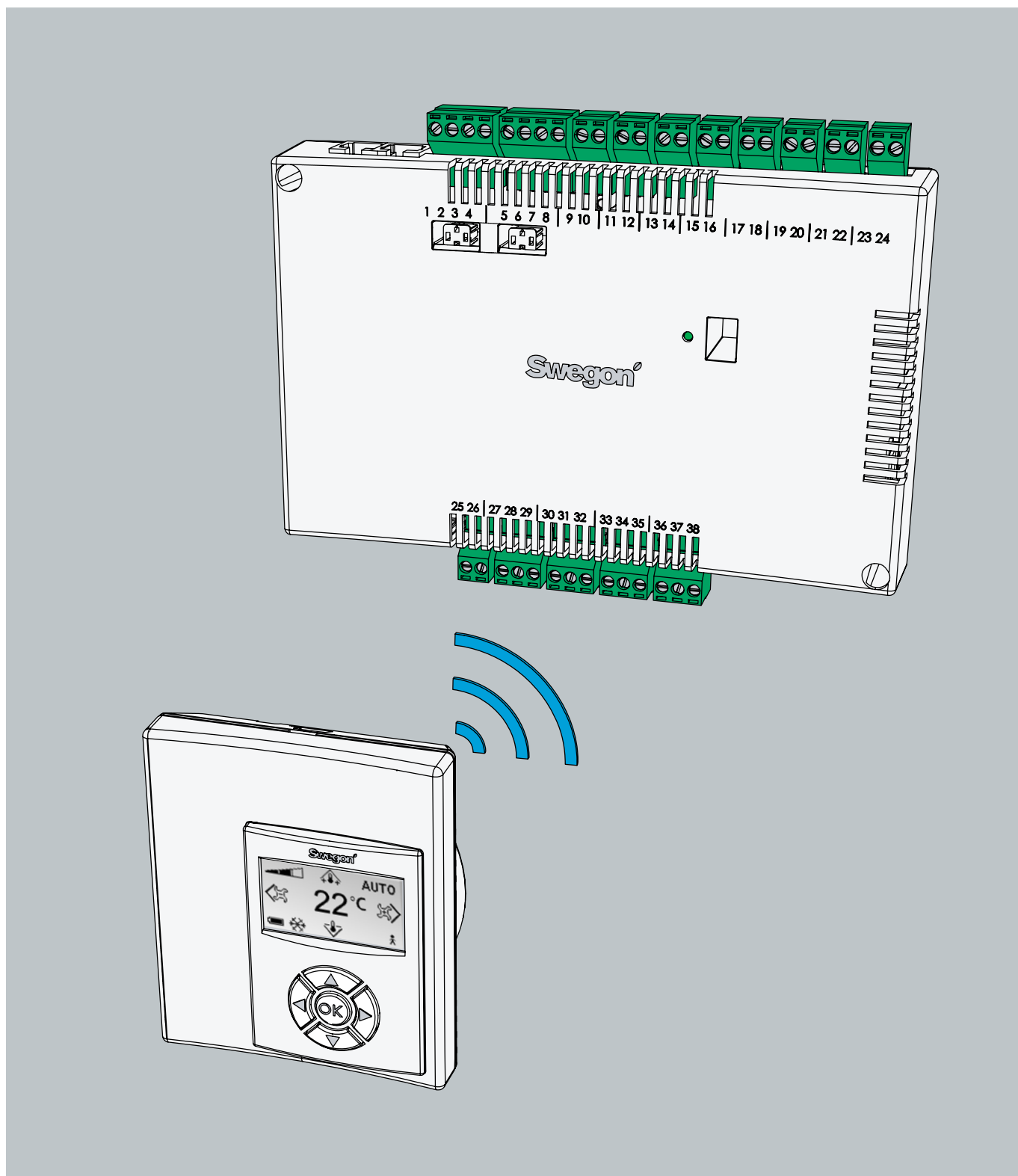

Updated: 2013-05-28
SW version 0.76

Swegon

Contents

Introduction and Safety	5
About this Manual.....	5
Product Design Changes.....	5
Safety Precautions	5
Technical Description	7
About Conductor W4.....	7
Controller and Room Unit (thermostat).....	7
Installation Examples	10
Adjustable Sequences for Cooling.....	13
Operating Mode.....	14
Operating Modes	15
Functions.....	16
C-Factor and Offset	18
Technical Data	19
Installation	21
Ordering, Delivery and Electrical Installation.....	21
Preparations	22
Step 1, To Mount the Controller.....	23
Step 2, To Connect the Units	25
Step 3, Commissioning	29
Step 4, To Install the Room Unit (thermostat).....	31
The Menus of the Room Unit (thermostat).....	33
The Main Image and the Key Pad of the Room Unit.....	33
Overview of the Menu System of the Room Unit. ...	35
Navigating in the Menus of the Room Unit	36
Changes in the Main Image	37
Changes and Settings in the Service Menu	38
Service	49
Parameters	49
System Parameters.....	49
Application Parameters.....	51
Indication on the Controller	57
Trouble shooting	58
ModBus Register	60



Introduction and safety

About this manual

This manual is intended for use by the members of the staff who are responsible for maintenance of the climate system and it contains the following information:

- Technical description of the CONDUCTOR W4 controller.
- Installing and commissioning the CONDUCTOR W4 controller .
- Instructions on how the various settings should be entered in the room unit (thermostat).

The Service section is intended for personnel who are specially trained by Swegon.

Product design changes

Swegon reserves the right to change the specifications in the manual and change the design of the product without notice.

Safety precautions

Responsibility

It is the responsibility of the user to do the following:

- Assess all the risks involved in the activities which are related to this manual.
- Make sure that all necessary safety precautions are made before starting the activities which are related to this manual.

Safety levels

The following levels of safety warnings are used in this manual:

**WARNING:**

Used when there is risk of damage to persons or equipment.

**N.B.!**

Used to point out important information.

Technical Description

About Conductor W4

CONDUCTOR W4 is a controller application in the CONDUCTOR series. The W designation indicates that the application is applicable to water-borne climate systems.

CONDUCTOR is a control system for the individual control of room temperature and airflow. It can operate independently or in combination with a central system.

CONDUCTOR W4.2/W4.1

CONDUCTOR W4 is available in two variants. W4.2 especially adapted for conference rooms, and CONDUCTOR W4.1 especially adapted for partitioned offices and hotel rooms.

Controller and Room Unit (thermostat)

The main components in the CONDUCTOR W4 control system are a controller and a room unit (thermostat).

Controller

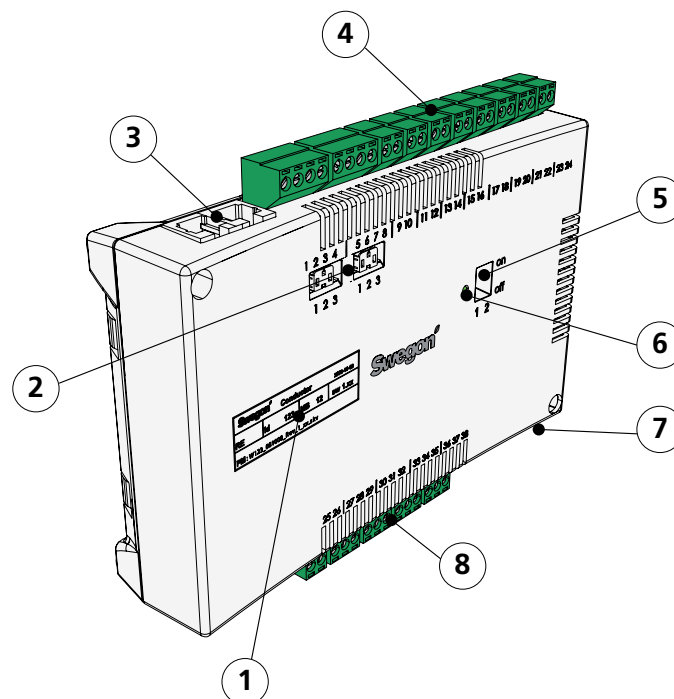

Figure 1. Overview of the Controller.

- Pos 1. Product marking.
- Pos 2. Termination resistance.
- Pos 3. Modbus RTU units.
- Pos 4. Inputs: Wiring terminals for the connection of sensors.
- Pos 5. DIP switch for ModBUS RTU.
- Pos 6. LED, indicates the status of the controller.
- Pos 7. Input and output for signal to external relay.
- Pos 8. Outputs: Wiring terminals for the connection of valve and damper actuators.

The controller is equipped with inputs for connection of a condensation sensor, carbon dioxide sensor, window switch, presence detector and outputs for the connection of actuators for valves and air dampers.

Up to twelve pairs of actuators (twelve for cooling + twelve for heating) can be wired to each controller. Or you can connect up to four complete units per controller for controlling both the airflow (supply air and central extract air, 5 damper actuators) and cooling and heating (cooling and heating circuit, valve actuators).

The controller provides proportional and integral (PI) control. Through so-called PWM control (pulse width modulation), the I section senses both the size and the duration of the control deviation and adjusts the actuator opening time accordingly. It is possible to switch over from PWM control to 0-10 V control, if needed.

The user can easily configure the controller functions and parameters by means of the room unit (thermostat).

The controller has a built-in communication port that enables connection to an RS 485 network with ModBus RTU for supervising and override control via a main control system.

Product Identification Label

The product identification label affixed to the front of the controller, indicates rated data, the controller ID-number, which you will need when you install the CONDUCTOR.

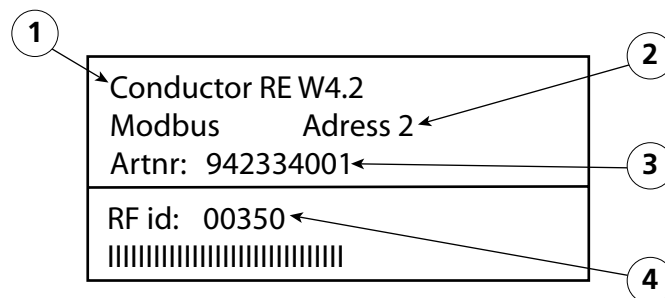

Figure 2. Product identification label on the controller.

- Pos 1. Name of the product.
- Pos 2. ModBus RTU address.
- Pos 3. Part number.
- Pos 4. Controller ID number.

Room Unit

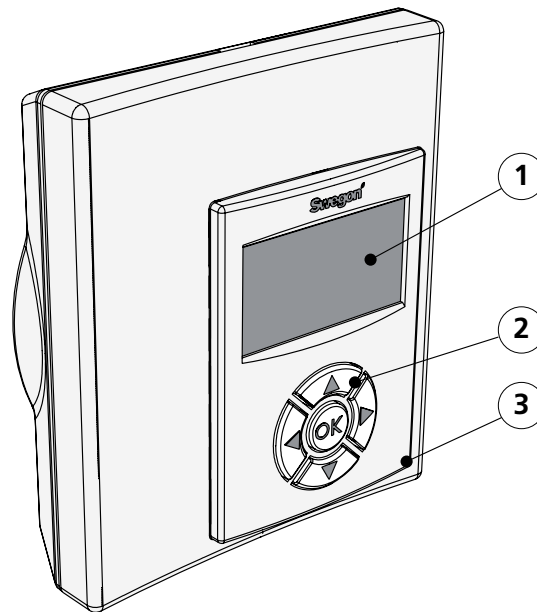

Figure 3. Overview of the room unit (thermostat).

Pos 1. Display

Pos 2. Keypad.

Pos 3. Temperature sensor.

The room unit is simple to use and has an easy-to-interpret design that makes it user-friendly. The digital display shows the current preset temperature and airflow settings.

The function of the room unit is to measure the temperature in the room, communicate with the controller and to serve as a tool for adjusting the climate in the room.

The internal communication between the controller and the room unit is wireless, which makes it easier to find an appropriate spot in the room where the room unit can be installed.

If requested, the room unit can be wire-connected to the controller. All cable connections are hidden above the false ceiling and all wiring is carried out with detachable standard connections, i.e. screw wiring terminals.

Installation Examples

The illustration below shows a typical arrangement of a complete installation with the CONDUCTOR W4.2 control system.

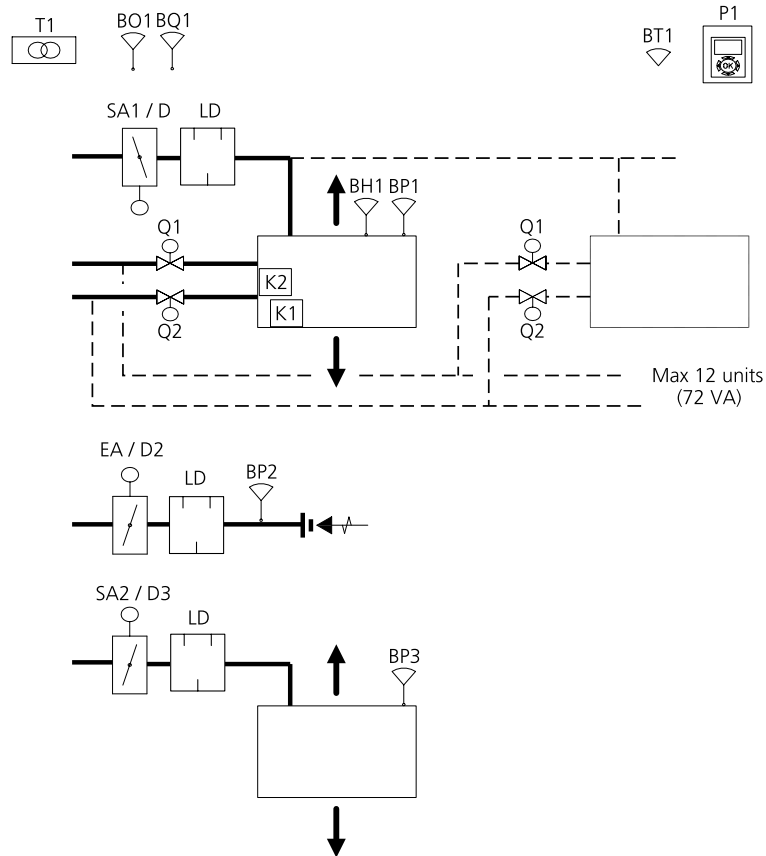

Figure 4. Example of a CONDUCTOR W4.2 installation.

CONDUCTOR W4.2 (Conference Room)		
PARASOL	PARASOL-xxxx-B	Comfort module
K1/ K2	CONDUCTOR RE W4.2	Controller
BT1 / P1	CONDUCTOR RU	Room unit
BH1	SYST CG	Condensation sensor
BP1 SA	SYST PS	Pressure sensor, supply air
BP2 EA	SYST PS	Pressure sensor, exhaust air
BP3 SA2	SYST PS	Pressure sensor, supply air 2
BO1	DETECT Occupancy	Presence detector
BQ1	DETECT Quality	CO ₂ sensor, 2-10 V
SA1 / D1	CRTc-(aaa)-2	Supply air damper 1 including motor
EA / D2	CRTc-(aaa)-2	Extract air damper including motor
SA2 / D3	CRTc-(aaa)-2	Supply air damper 2 including motor
Q1	LUNA a AT-2	Valve actuator, cooling
Q2	LUNA a AT-2	Valve actuator, heating
T1	SYST TS-1	Transformer
LD	CLA 125-500	Sound attenuator

Installation Examples

The illustration below shows a typical arrangement of a complete installation with the CONDUCTOR W4.1 control system.

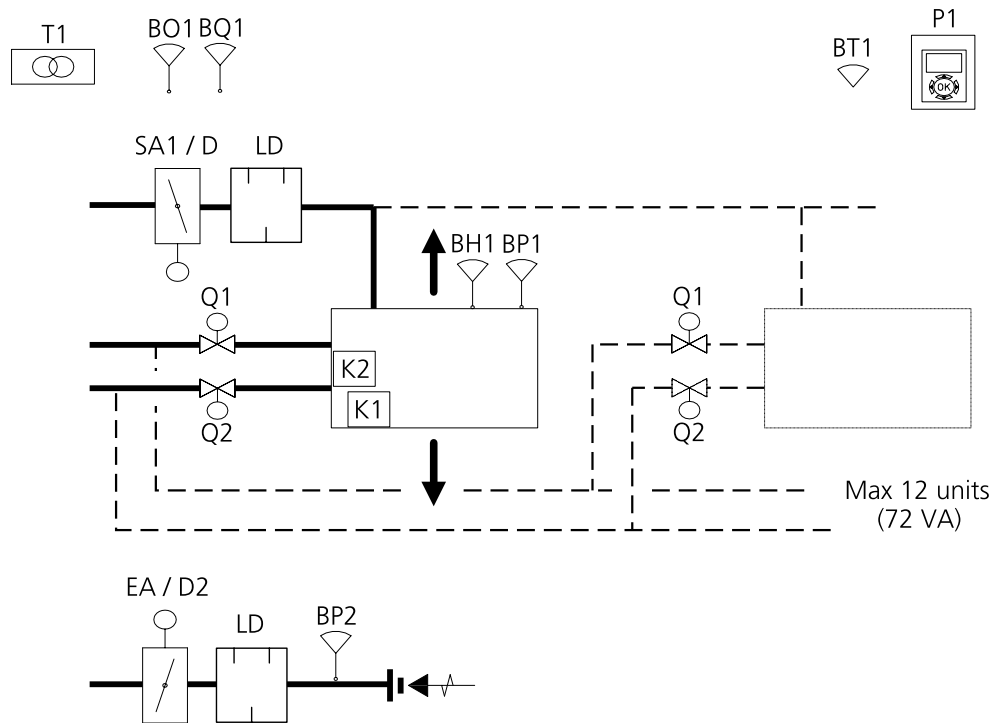

Figure 5. Example of a CONDUCTOR W4.1 installation..

CONDUCTOR W4.1 (Hotel/Office)		
PARASOL	PARASOL-xxxx-B	Comfort module
K1/ K2	CONDUCTOR RE W4.1	Controller
BT1 / P1	CONDUCTOR RU	Room unit
BH1	SYST CG	Condensation sensor
BP1 SA	SYST PS	Pressure sensor, supply air
BP2 EA	SYST PS	Pressure sensor, exhaust air
BO1	DETECT Occupancy	Presence detector
BQ1	DETECT Quality	CO ₂ sensor, 2-10 V
SA1 / D1	CRTc-(aaa)-2	Supply air damper 1 including motor
EA / D2	CRTc-(aaa)-2	Extract air damper including motor
Q1	LUNA a AT-2	Valve actuator, cooling
Q2	LUNA a AT-2	Valve actuator, heating
T1	SYST TS-1	Transformer
LD	CLA 125-500	Sound attenuator

Installation Examples

The illustration below shows a typical arrangement of a complete installation with the CONDUCTOR W4.1 control system.

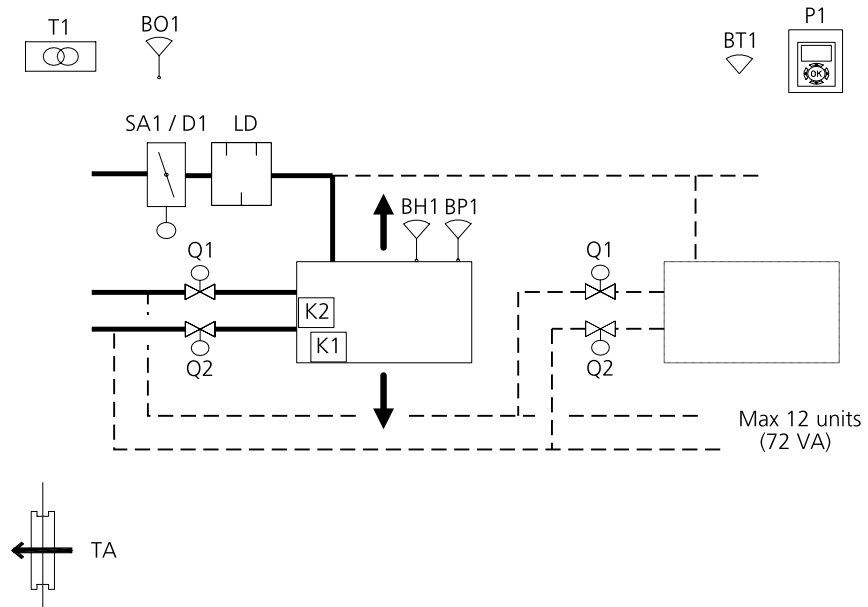

Figure 6. Example of a CONDUCTOR W4.1 installation..

CONDUCTOR W4.1 (Hotel/Office)		
PARASOL	PARASOL-xxxx-B	Comfort module
K1/ K2	CONDUCTOR RE W4.1	Controller
BT1 / P1	CONDUCTOR RU	Room unit
BH1	SYST CG	Condensation sensor
BP1 SA	SYST PS	Pressure sensor, supply air
BO1	DETECT Occupancy	Presence detector
SA1 / D1	CRTc-(aaa)-2	Supply air damper 1 including motor
Q1	LUNA a AT-2	Valve actuator, cooling
Q2	LUNA a AT-2	Valve actuator, heating
T1	SYST TS-1	Transformer
LD	CLA 125-500	Sound attenuator
TA	RGVb	Transfer grille

Adjustable Sequences for Cooling

The controller can be set for one of two different sequences for cooling:

- Air – Water with temperature - and carbon dioxide control
- Water – Air with temperature - and carbon dioxide control

Air – Water with temperature - and carbon dioxide control

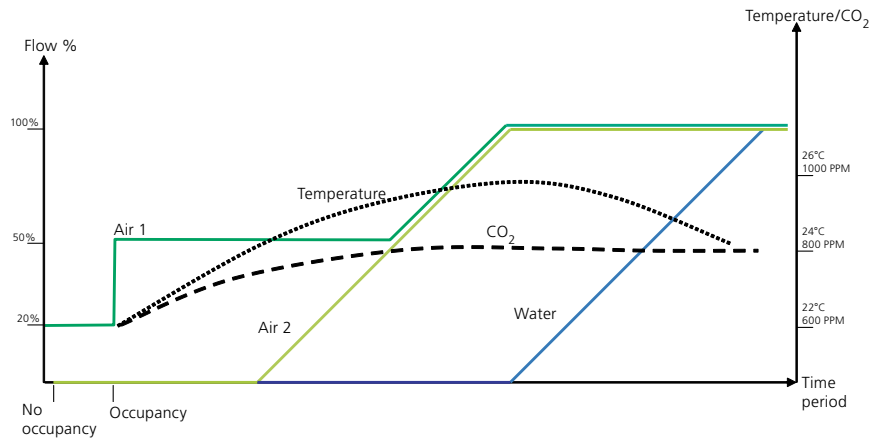

Figure 7. Typical diagram dealing with the air-to-water sequence with temperature control.
Note! Air 2 is valid only for W4.2

The sequence involves the following: If occupancy is registered in the room and if the temperature is at a certain level, the system starts a cooling process that cools down the room by increasing the airflow.

If the temperature rises more and the increased airflow is not sufficient for maintaining the required temperature, the cooling process is supplemented with cooling by circulating chilled water in the water pipes.

If the level of carbon dioxide in the room exceeds a certain level, the air system is activated in order to reduce the level and keep it constant.

Water – Air with temperature control

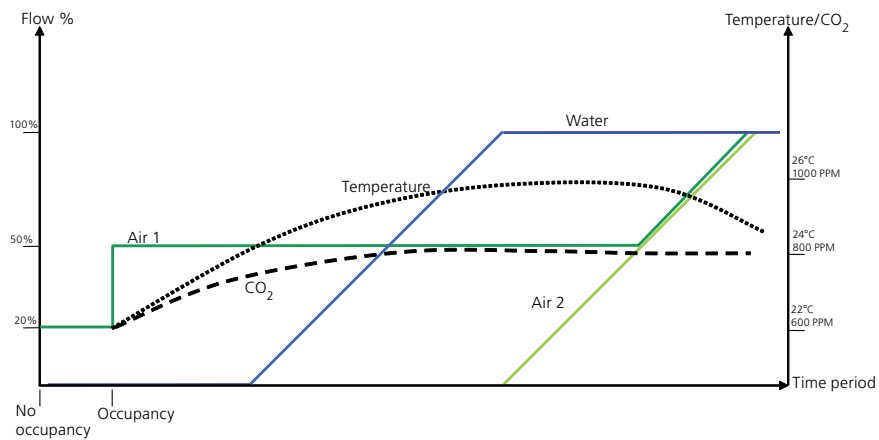

Figure 8. Typical diagram dealing with the water-to-air sequence with temperature control.
 Note! Air 2 is valid only for W4.2

The sequence involves the following: If occupancy is registered in the room and if the temperature is at a certain level, the system starts a cooling process that cools down the room by circulating chilled water in the water pipes.

If the temperature rises more and the chilled water is not sufficient for maintaining the required temperature, the cooling process is supplemented by increasing the airflow.

If the level of carbon dioxide in the room exceeds a certain level, the airflow is increased in order to reduce the level and keep it constant.

Operating Mode

Depending on the status of connected sensors, the controller adjusts the outputs from any of several possible operating conditions.

The various operating conditions described here are based on occupancy in the room and the status of the window contact, condensation sensor, carbon dioxide sensor and the current pressure.

Occupancy	Window	Condensation	Carbon dioxide	Airflow	Cooling
No	No	No	No	Low	ECON
Yes	No	No	No	Normal	Normal
Yes	Yes	No	No	Low	Closed
Yes	No	Yes	No	High	Closed
Yes	No	No	Yes	High	Normal
Yes	No	No	No	Normal	Normal

Operating Modes

There are a variety of functions built into the CONDUCTOR:

- MAN, manual mode.
- AUTO, automatic mode.
- ECON, energy-saving mode.
- Holiday, energy-saving mode.
- Boost, extra air supply.
- Timer, timed extra air supply.
- Stand-by mode, idle position.
- EMERG, emergency mode.

MAN, Manual operating mode.

Whenever the CONDUCTOR registers occupancy in the room in response to signals from a presence detector, the user can regulate the temperature and airflow rate by entering settings in the room unit. When the user enters a new desired setting, the controller switches over to the manual operating mode (MAN).

AUTO, Automatic operating mode.

When the CONDUCTOR no longer registers occupancy in the room, the controller automatically decreases the supply air flow to the low airflow setting and the system automatically returns to the AUTO mode.

The controller also switches automatically to the AUTO mode after a predefined number of minutes after the most recent change, manually entered on the room unit.

When the controller is set to the automatic mode, the valve actuators for chilled water and hot water respectively and the supply air damper and extract air damper respectively are adjusted in response to occupancy in the room and the level of carbon dioxide as well as the status of the window contact and the condensation sensor.

The automatic control system controls the airflow, cooling and heating until the user manually enters a new airflow or temperature setting.

ECON, energy-saving mode.

When the energy-saving function is enabled, the system switches automatically to the ECON energy-saving mode, when no occupancy has been registered for a predefined number of minutes. The system returns to the AUTO mode when occupancy is registered again.

In the energy-save mode, the valve actuator is controlled for chilled water and hot water respectively according to the status on other sensors in the room, but with a greater permissible difference between actual value and setpoint than in the AUTO mode.

Holiday, Energy-saving operating mode

When a room is not in use, it is possible via a main control system to continue RE in the holiday mode.

The required airflow and switch in times for cooling and heating can be selected in the holiday mode.

Boost, extra air supply

When the need for more air arises, the RE switches over to operate in the Boost mode. This can occur for example when the CO₂ level increases, or if the temperature rises above the desired level in the room and more air needs to be pressed in to increase the cooling capacity.

Timer, timed extra air supply.

The timer function is used for ventilating the room extra when the first occupant enters the room after the room ventilation system has been operating in the ECON/Holiday mode. The RE then operates in the Boost mode.

The time is set with one parameter, factory preset to 5 min.

Stand-by mode.

When the control system registers a signal indicating that a window is open, the controller switches over to the standby mode. When the window is closed, the controller switches to the AUTO operating mode.

While the controller is in the Stand-by mode, the room temperature is maintained above the predefined level for the Frost protection function.

EMERG, emergency mode.

In the event of a fire alarm, the air damper in the extract air duct is opened or closed, depending on the setting entered in the control system. The cooling and heating functions are shut off while the system is in the EMERG mode. The supply air is normally shut off.

The EMERG mode can only be managed in control systems that are connected to a main control system via ModBus RTU.

Functions

There are a variety of functions built into the CONDUCTOR W4:

- Exercising of valves
- First open
- 0-point calibration
- Frost protection
- Change over
- Night cool
- Time-set setpoint restoration

Exercising of valves

The function involves regularly exercising the water valves by utilising automated functions in order to prevent them from becoming sluggish or jamming. During the exercising period, all the valves that are wired to the controller are opened for a maximum of 6 minutes and are then closed. The valves for the cooling system are exercised first. Then the valves for the heating system are exercised.

First open

The function means that the water valves are open when the system is installed, which makes it easier to fill, pressure test and vent the water system.

The function will be automatically disabled after the actuator has been energized for approx. 6 minutes. A clicking noise will be heard when the valves and the dampers change over to the NC mode (=normally closed) and the normal control function is enabled.

Zero Calibration

Zero calibration of the pressure sensors connected to the RE: The dampers are closed and a calibration signal is transmitted to the pressure sensor, after which the RE returns to the relevant operating mode.

The time interval is set with the appropriate system parameter and is specified in hours.

Frost protection

The function involves the following: Heating operation is started at a predefined room temperature in order to counteract the risk of damage that otherwise can arise due to freezing.

Change over

The function involves the use of only one valve actuator connected to the cooling output. This valve actuator then controls both the heating water and the cooling water, which are transported in the same pipe.

In the wintertime, when heating is required, the valve opens if the water in the pipe is hotter than the temperature setpoint. If the water is colder, the valve is not opened.

In the summer, when cooling is required, the valve opens if the water in the pipe is colder than the temperature setpoint.

An external temperature sensor must be mounted on the water pipe with continuous inlet water circulation in order to be able to use the function.

Night cool

The function involves using cold air from outdoors for cooling the room at night to the predefined level.

The function can only be managed in control systems that are connected to a main control system via ModBus RTU.

Time-set setpoint restoration

The function involves adjusting the room temperature to the predefined level when the controller switches to the AUTO operating mode.

The controller also switches automatically to the AUTO mode after a predefined number of minutes after the most recent change, manually entered on the room unit.

C-Factor and Offset

C-Factor

The controller calculates how the air dampers should open and close in order to achieve the required airflow.

A so-called C-factor, which is a value for resistance, is used in the calculation. Utilizing the C-factor and the pressure in each air duct, the controller calculates the flow in the air duct.

Offset

A balanced pressure, a positive pressure or a negative pressure can be created in order to provide satisfactory ventilation in the room. Using a so-called Offset value, the controller carries out a calculation in order to achieve the required pressure in the room.

$\text{Pressure} = \text{SA1} + \text{SA2} + \text{Offset}$

The value 0 for Offset gives rise to a balanced pressure. A negative value for Offset gives rise to a positive pressure whereas a positive value gives rise to a negative pressure.

- Balanced pressure = Just as much supply air as extract air.
- Negative pressure = More extract air than supply air.
- Positive pressure = Less extract air than supply air.



Technical Data

CONDUCTOR RE Controller

Technical data applicable to the CONDUCTOR RE controller (W4) is specified below.

Item	Data
Designation	CONDUCTOR RE (W4)
Storage temperature	-40 °C to +80 °C
Operating temperature	-20 °C to +50 °C
Degree of protection	IP 32
Dimensions	121 x 193 x 44 mm
Supply voltage	24V AC \pm 10%
Power consumption	1 VA
Control function	PI
P-band, cooling/heating increments	1 K
Valve installation	1 time/48h period (fully open for 3 minutes)
Installation	Mounting holes in enclosure or onto DIN rail
Connections	Wiring terminal for 2.5 mm ² multicore cable
Data communication	ModBus RTU
Wireless communication	433 MHz band radio modem with room unit (thermostat)
Frost protection	10 °C
Switch in temperatures	
Occupancy, cooling	23 °C
Occupancy, heating	21 °C
No occupancy, cooling	24 °C
No occupancy, heating	20 °C
Inputs	
Condensation sensor	Resistance
Temperature sensor	Resistance
Presence detector	No occupancy/NO/NC (optional), default = NC for occupancy
Window contact	No occupancy/NO/NC (optional), default = NC for closed window
Carbon dioxide sensor	2 - 10 V, or 24 V
Pressure sensor/ModBus RTU sensor	2 - 10 V / RJ12 cable
Modular contact	RJ12 6-pole for connecting up to the room unit (thermostat) RJ12 6-pole for connecting up to ModBus RTU
Outputs	
Actuator, heating W4.2	24 V AC, (on/off) max load 72 VA = 12 actuators
Actuator, heating W4.1	24 V AC, PWM (on/off or 0 - 10 V) max load: 72 VA = 12 actuators
Actuator, cooling	24 V AC, PWM (on/off or 0 - 10 V) max load: 72 VA = 12 actuators
Supply air damper	0 - 10 V DC (low/normal/high) max load 25 VA = 5 actuators.
Extract air damper	0 - 10 V DC (low/normal/high) max load 25 VA = 5 actuators.

CONDUCTOR RU room unit (thermostat)

Item	Data
Designation:	CONDUCTOR RU
Storage temperature	-40 °C to +80 °C (*)
Operating temperature	0 °C to +50°C
Degree of protection	IP 20
Dimensions	86 x 100 x 32 mm
Supply voltage	12 V, 4 size AAA batteries
Actual value, range	+10 °C to +32°C
Installation	Against a wall or in a 70 mm standard junction box. Must not be exposed to direct sunlight
In-operation LED, temperature	Cooling load
	Heating load
In-operation LED, air	Low airflow: One LED lit 
	Normal airflow: Two LEDs lit 
	High airflow: Three LEDs lit 
In-operation LED, enabled	Lit LED, AUTO
In-operation LED, disabled	Dimmed display, AUTO
Input	
Modular contact	RJ12 6-pole for connecting up to the controller (**)

(*) = Specified storage temperature applies to a room unit WITHOUT batteries.

(**) = Used only if wireless communication is not desired.

Installation

Ordering, delivery and electrical installation

Ordering key, Control equipment

Item	Data
Controller W4	CONDUCTOR RE W4.1 alt. W4.2
Room unit (Thermostat)	CONDUCTOR RU

Ordering Key, Accessories

Item	Data
Valve	SYST VD 115-CLC
Valve actuator	LUNA a AT-2
Ventilation damper incl. damper actuator	CRTc (aaa)-2
Condensation sensor	SYST CG
Carbon dioxide sensor	DETECT Qyality
Presence detector	DETECT Occupancy
Pressure sensor / ModBus sensor	SYST PS
Modular cable	SYST KABEL RJ12 6-LED. L=Xm
Transformer	SYST TS
External temperature sensor	CONDUCTOR T-TG
Adapter, actuator/valve	LUNA a T-VA-(aa)
(aa) = Fitted to valve type:	
32	Tour & Andersson
39	Oventrop
50	Honeywell, Reich, MNG, Böhnisch (H), Cazzaniga
54	Certain MMA-valves
59	Danfoss RAV/L
72	Danfoss RAV
78	Danfoss RA
80	Siemens and more (always included in the LUNA a AT-2 actuator)
(aaa) =	100 or 125

Ordering

Specify the desired number of ordered components or refer to drawing.

Delivery

- The valves are delivered to the plumbing contractor for installation in the system.
- The room controller is delivered to the electrical contractor, systems contractor or other contractor for installation onto the junction box.
- Controller is normally delivered factory fitted on the comfort module or climate beam. The controller is delivered to electrical contractor, systems contractor or other contractor for installation by means of screws at some other suitable place, if separate components are supplied.



WARNING:

All electrical installation, including wiring the actuators, valve actuators and various sensors is to be carried out by the electrical contractor or the systems contractor.

The electrical contractor or the systems contractor provides a 230 V earthed outlet for transformer, a fitted junction box for the room unit (thermostat) and possible external cables.

Preparations

The CONDUCTOR W4 should be installed in steps as follows:

1. To mount the controller.
2. To connect units.
3. Commissioning.
4. To mount the room unit (thermostat).

Check the following before installing the CONDUCTOR W4:

- The comfort module, with pre-fitted valve actuators for chilled and hot water, are mounted in the ceiling.
- The required sensors (e.g. presence detector, window contact and condensation sensor) are installed in the room.
- Required actuators are installed.
- Cables from all the units are marked and run up to the comfort module, or alternative location for the controller.

The following are required for installation:

- ordinary screwdriver or electric screwdriver
- Electric drill.

Step 1, To mount the controller.

Mounting on a DIN rail

If a DIN rail is mounted on the comfort module or at another suitable location, the controller should be fastened to this rail.

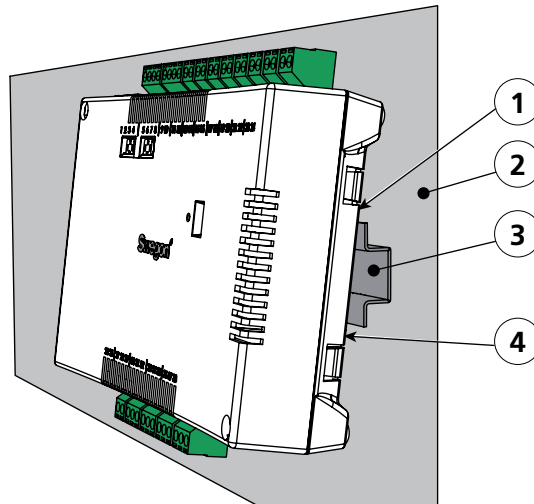

Figure 1. To mount the controller.

Pos 1. Plastic hooks

Pos 2. Supporting surface, for example a comfort module or climate beam.

Pos 3. DIN rail

Pos 4. Snap-on fastener.

1. Fasten the two plastic hooks on the backside of the controller on the upper control edge on the DIN rail.
2. Press to fasten the snap-on fasteners on the backside of the controller against the lower control edge on the DIN rail.

To be installed above a false ceiling

If a DIN rail is NOT available pre-mounted or is not available, the controller can be appropriately mounted above the false ceiling (**not** on the comfort module or climate beam).

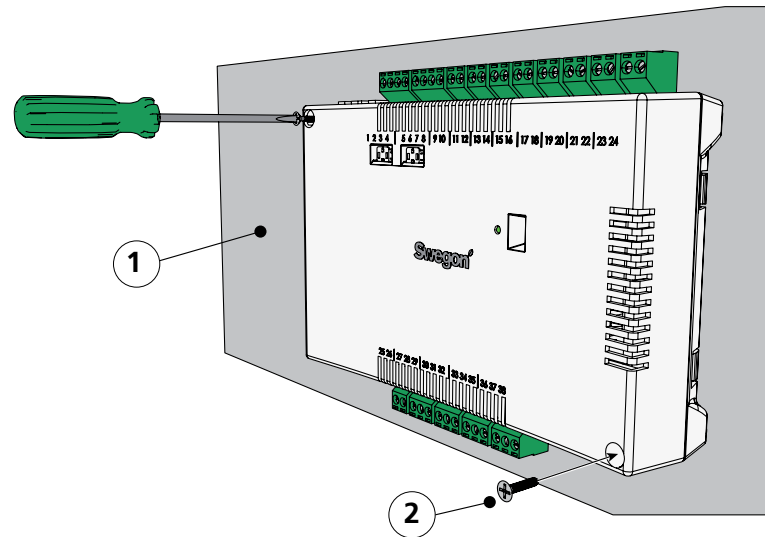

Figure 2. To mount the controller.

Pos 1. Supporting surface, NOT for the comfort module or climate beam.

Pos 2. Screws.

1. Secure the controller by means of screws in the upper left-hand and the lower right-hand corners. Use screws suitable for the supporting surface.

Step 2, Installation of units

The following units should be connected to the detachable wiring terminals of the controller:

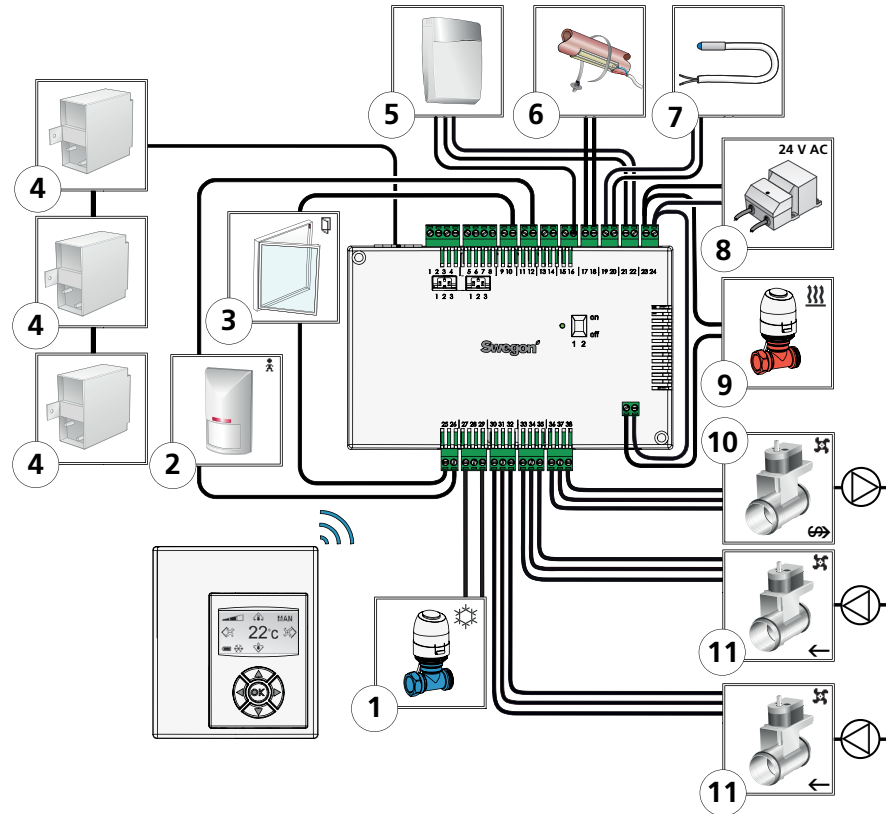

Figure 3. Overview of the units - W4.2. (Conference)

- Pos 1. Valve actuator for cooling water.
- Pos 2. Presence detector.
- Pos 3. Window contact.
- Pos 4. Pressure sensor.
- Pos 5. Carbon dioxide sensor.
- Pos 6. Condensation sensor
- Pos 7. Temperature sensor.
- Pos 8. Transformer
- Pos 9. Valve actuator for heating water.
- Pos 10. Damper motor for extract air.
- Pos 11. Damper motor 1 for supply air.
Damper motor 2 for supply air.

1. Connect the valve actuator for cooling water to wiring terminals 27 and 29 respectively.
2. Connect the presence sensor to wiring terminals 12 and 26 respectively.
3. Connect the window contact (normally closed or normally open) to wiring terminals 10 and 25 respectively.
4. Connect the pressure sensor to the Modular contact. Set the address on sensor.
SA1 = 3
SA2 = 6
EA = 4
5. Connect the carbon dioxide sensor as follows:
 - 0-10 V signal: Wiring terminal no. 16
 - G: Wiring terminal no. 21.
 - G0: Wiring terminal no. 22.
6. Connect the wires of the condensation sensor to wiring terminals 17 and 18 respectively.
7. Connect the wires of the temperature sensor to wiring terminals 19 and 20 respectively
8. Connect the secondary side cables of the transformer to wiring terminals 23 (G) and 24 (GO) respectively.
9. Connect the valve actuator for heating water as follows:
 - Relay contact located under the casing of the controller.
 - To wiring terminal no. 23.
 - To wiring terminal no. 24.
10. Connect the damper motor for extract air as follows:
 - G0: Wiring terminal no. 36.
 - 0-10 V signal: Wiring terminal no. 37.
 - 24 V: Wiring terminal no. 38.
11. Connect the damper motor 1 for supply air as follows:
 - G0: Wiring terminal no. 33.
 - 0-10 V signal: Wiring terminal no. 34.
 - 24 V: Wiring terminal no. 35.
12. Connect the damper motor 2 for supply air as follows:
 - G0: Wiring terminal no. 30.
 - 0-10 V signal: Wiring terminal no. 31.
 - 24 V: Wiring terminal no. 32.

Step 2, Installation of units

The following units should be connected to the detachable wiring terminals of the controller:

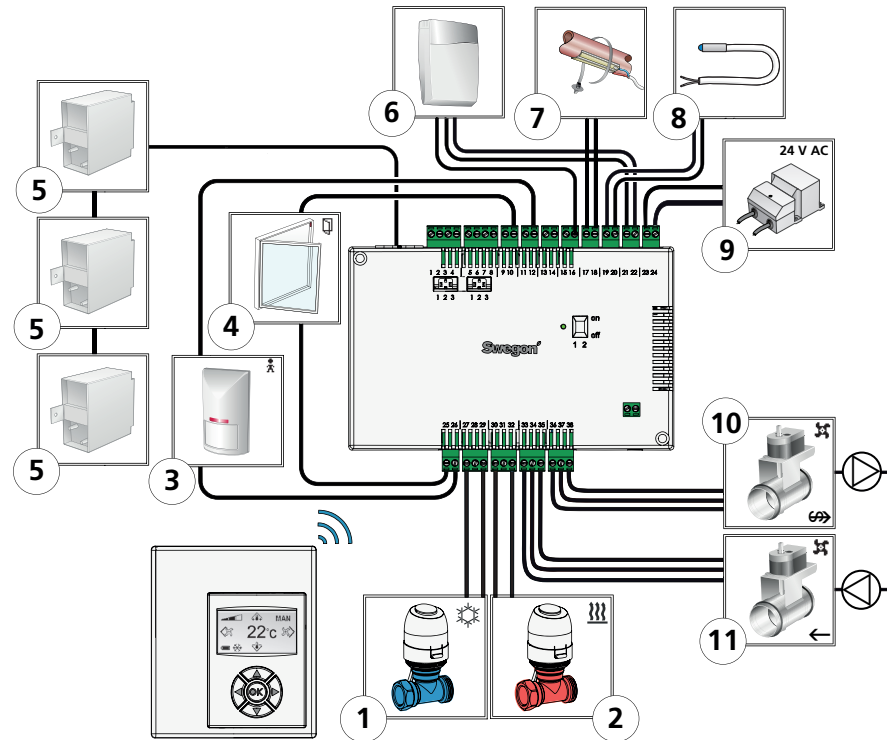

Figure 4. Overview of the units - W4.1. (Hotel/Office)

- Pos 1. Valve actuator for cooling water.
- Pos 2. Valve actuator for heating water.
- Pos 3. Presence detector.
- Pos 4. Window contact.
- Pos 5. Pressure sensor.
- Pos 6. Carbon dioxide sensor.
- Pos 7. Condensation sensor.
- Pos 8. Temperature sensor
- Pos 9. Transformer
- Pos 10. Damper motor for extract air.
- Pos 11. Damper motor for supply air.

1. Connect the valve actuator for cooling water to wiring terminals 27 and 29 respectively.
2. Connect the presence sensor to wiring terminals 12 and 26 respectively.
3. Connect the window contact (normally closed or normally open) to wiring terminals 10 and 25 respectively.
4. Connect the pressure sensor to the Modular contact. Set the address on sensor.
SA1 = 3
SA2 = 6
EA = 4
5. Connect the carbon dioxide sensor as follows:
 - 0-10 V signal: Wiring terminal no. 16
 - G: Wiring terminal no. 21.
 - G0: Wiring terminal no. 22.
6. Connect the wires of the condensation sensor to wiring terminals 17 and 18 respectively.
7. Connect the wires of the temperature sensor to wiring terminals 19 and 20 respectively
8. Connect the secondary side cables of the transformer to wiring terminals 23 (G) and 24 (GO) respectively.
9. Connect the valve actuator for heating water as follows:
 - Relay contact located under the casing of the controller.
 - To wiring terminal no. 30.
 - To wiring terminal no. 32.
10. Connect the damper motor for extract air as follows:
 - G0: Wiring terminal no. 36.
 - 0-10 V signal: Wiring terminal no. 37.
 - 24 V: Wiring terminal no. 38.
11. Connect the damper motor for supply air as follows:
 - G0: Wiring terminal no. 33.
 - 0-10 V signal: Wiring terminal no. 34.
 - 24 V: Wiring terminal no. 35.

Step 3, Commissioning

To connect the mains power supply cable

1. Connect the transformer's mains power supply cable to an electric outlet.

To insert batteries in the room unit (thermostat)

The room unit is normally supplied with electric current from four size AAA batteries.

As an alternative to batteries, the room unit can be energized from the controller, via a 6-pole cable with RJ12 modular connectors.



N.B.!

If the room unit is energized via a controller, the cable must be connected at this point.

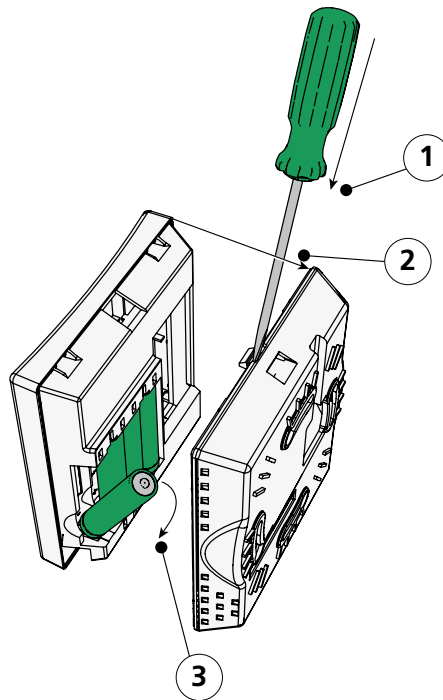

Figure 5. To insert batteries in the room unit (thermostat).

Pos 1. To open the snap-on fastener.

Pos 2. Remove the back piece.

Pos 3. To insert batteries.

2. Insert the batteries in the room unit (thermostat) as follows:
 - Open the snap-on fastener by pressing a screw driver in the notch between the front piece and back piece of the room unit.
 - Press on the snap-on fastener and remove the back piece.
 - Insert the batteries with the poles turned according to the relief markings in the battery compartment.

Booting

As soon as the controller and the room unit have been energized, the system boots up and the main view is shown in the display of the room unit.

The controller is in the AUTO operating mode when the system has finished booting.



Figure 6. Main view in the display of the room unit.

3. Check that the main view is shown in the display.

Selection of Language

On delivery, the room unit has factory-preset English language settings.

4. Change to desired language in accordance with instructions in the section: Room unit menus.

Check the factory settings

5. Make sure that the current application setting is in agreement with units connected to the controller. Check in accordance with instructions in the section: Room unit menus.

To connect units

In order for the controller to be able to properly communicate with the room unit, they must be connected up to one another.



N.B.!

If the room unit is operated via the controller, you need not connect it.

6. Connect the controller and the room unit to one another in accordance with the instructions in section: Room unit menus. The ID number of the controller should be given as address when connecting up.

Step 4, To install the room unit (thermostat)

The room unit contains a temperature sensor used for measuring the current room temperature. In order for the controller to regulate the temperature in relation to the preset setting, the room unit must be installed in such a way that enables it to correctly measure the temperature. The room unit should, for example, not be exposed to direct sunlight.

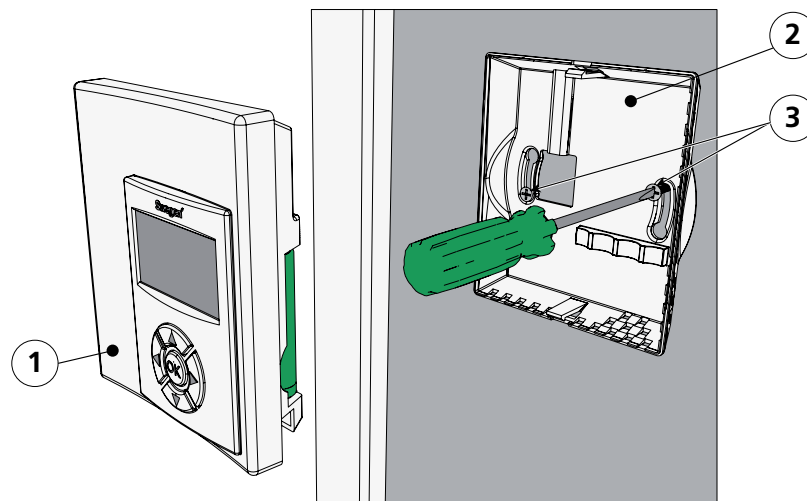

Figure 7. To mount the room unit (thermostat).

Pos 1. Front piece.

Pos 2. Back piece.

Pos 3. Screws suitable for the supporting surface.

1. Select a suitable location in the room for installing the room unit. The recommended height above the floor is standard height for of a light switch.
2. Remove the back piece from the room unit.



N.B.!

Tighten the back piece only in the right-hand and the left-hand fastening holes.

3. Then secure the back piece to the wall by means of two countersink screws, appropriate for the supporting surface.

The menus of the room unit (thermostat)

The main image and the key pad of the room unit

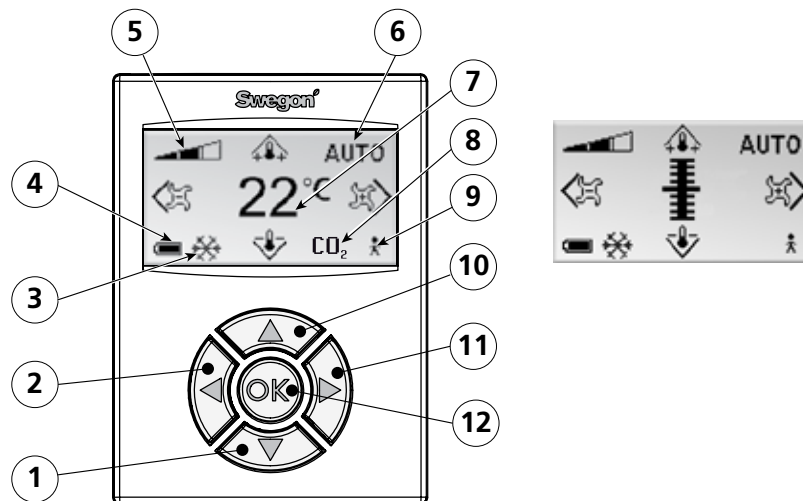



Figure 1. Overview of the main image of the room unit.

- Pos 1. Cursor key for moving DOWN.
- Pos 2. Cursor key for moving to the LEFT.
- Pos 3. Heating/cooling.
- Pos 4. Battery charge status/Window status.
- Pos 5. Current airflow.
- Pos 6. Operating mode.
- Pos 7. Current temperature.
- Pos 8. Carbon dioxide content.
- Pos 9. Occupancy status
- Pos 10. Cursor key for moving UP.
- Pos 11. Cursor key for moving to the RIGHT.
- Pos 12. OK key.

Heating/Cooling

The field shows whether the climate system is heating or cooling.

 Symbol for heating.

 Symbol for cooling.

Battery charge status/Window status

The field shows the battery level. If a window is open in the room this will be visible on the screen.

 Symbol for fully charged batteries.

 Symbol for half charged batteries.

 Symbol for empty batteries.

 Symbol for an open window.

Current airflow

The field shows the present airflow setting.

 Symbol for low airflow.

 Symbol for normal airflow.

 Symbol for high airflow.

Operating mode

The field shows the current operating mode. The field is empty if the unit is operating in the manual mode.

AUTO Automatic.

ECON Economy.

STOP Standby.

EMERG Emergency.

Current temperature

The field shows the current temperature setting. The temperature is specified in°C.

Level of carbon dioxide

The symbol is shown in the field when the carbon dioxide content in the room exceeds the pre-defined content.

 Symbol for carbon dioxide content.

Occupancy status

The symbol is shown in the field when someone is in the room.

 Symbol for occupancy.

Overview over the menu system of the room unit.

The menu system of the room unit consists of the following menus with associated submenus.

- Main menu
- Service menu

Main menu and Service menu

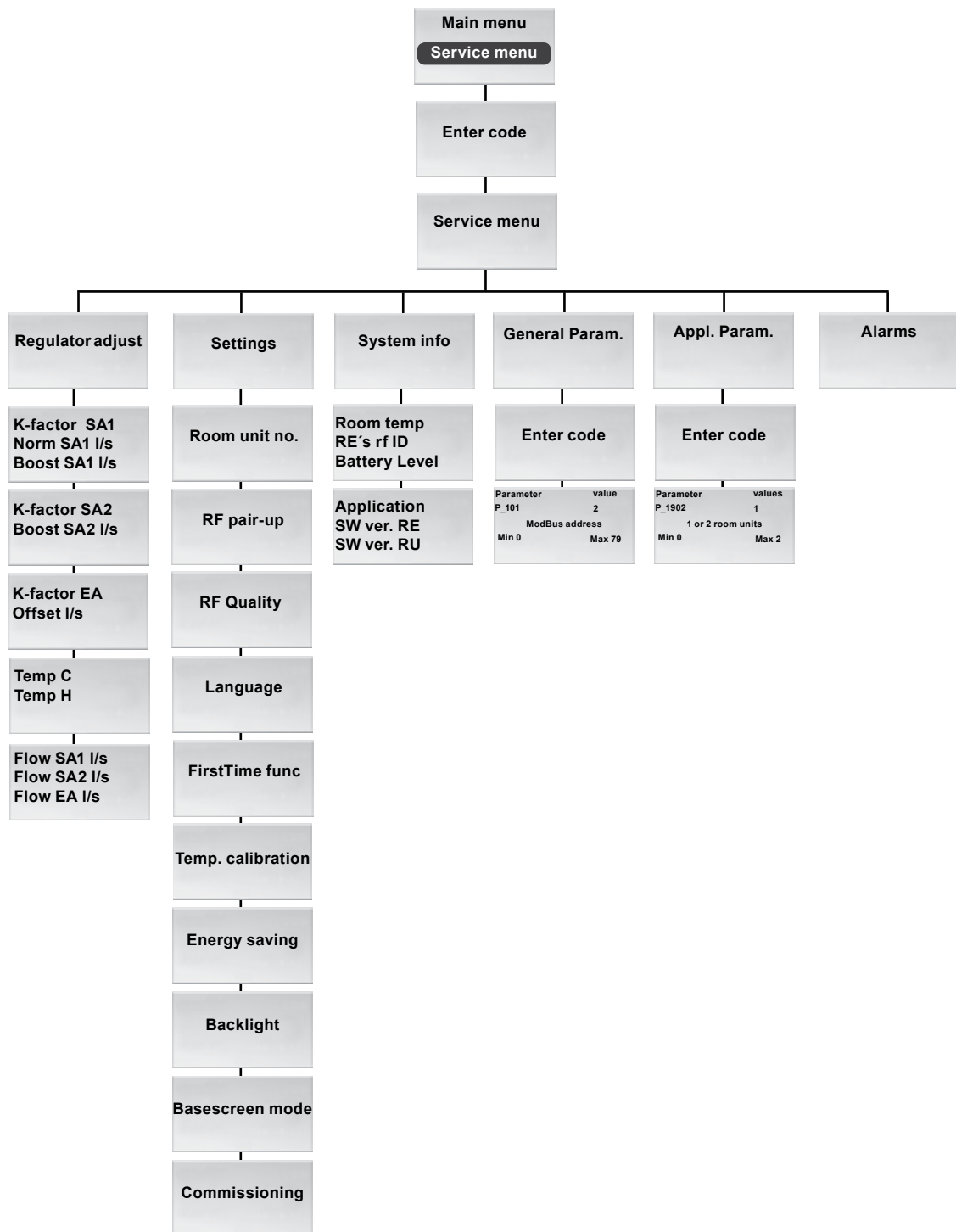

Navigating in the menus of the room unit

Go to the main menu

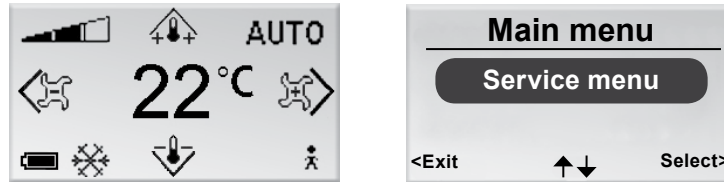

Figure 2. Main image and Main menu.

1. Press on the OK key while the main image is shown in the display and hold the key pressed down for 3 seconds.

Go to the Service menu

A authorization code must be entered in order to reach the Service menu.

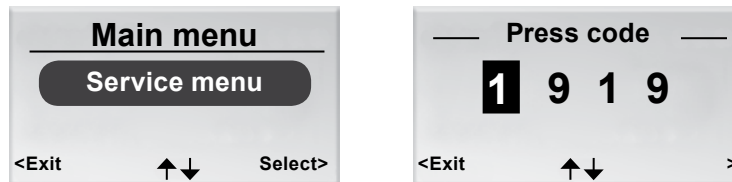

Figure 3. The image for selecting Service menu and to enter the code.

1. Go to the Main menu.
2. Highlight Service menu.
3. Press OK or on the ►Right key.
4. Enter the first digit in the code by pressing the ▲ UP or ▼ DOWN key.
5. Mark the next digit position by pressing the ► Right key.
6. Enter the remaining three digits in the code.
7. Press OK to confirm the code.
If you have entered the correct code, the Service menu will be shown. Otherwise the Main menu will be shown.

Changes in the Main image

To set the desired room temperature

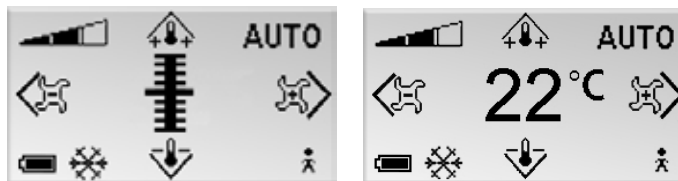

Figure 4. The Main image (Analog and Dialog display)

1. Check that the main image is shown in the display.
2. Press on:
 - The ▲ UP key to raise the temperature.
 - The ▼ DOWN key to lower the temperature.
3. Press OK or wait 3 seconds to confirm the setting.

To set the desired airflow



Figure 5. Main image.

1. Check that the main image is shown in the display.
2. Press on:
 - The ► Right key to increase the airflow.
 - The ◀ Left key to decrease the airflow.
3. Press OK or wait 3 seconds to confirm the setting.

Low airflow corresponds to the ECON operating mode. Normal airflow corresponds to the AUTO operating mode. High airflow corresponds to the BOOST operating mode.

Changes and settings in the Service menu

To set the air damper for supply air and to change the K-factor

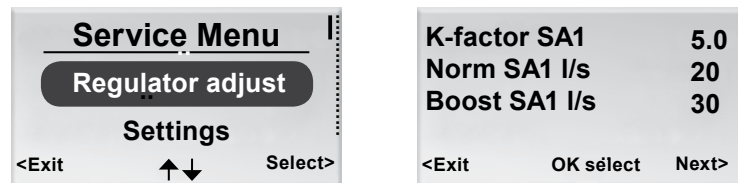

Figure 6. Image for selecting Regulator adjustment settings and view for setting the K-factor and the damper for supply air in air duct 1.

1. Go to the Service menu.
2. Highlight the Regulator adjustment settings.
3. Press OK or on the ►Right key.
4. Highlight the line of the value you want to change by pressing the ▲ UP key or the ▼ DOWN key.
5. Press OK to highlight the value.
6. To change the value:
 - K-factor.
 - Norm = the value applicable to normal airflow.
 - Boost = the value applicable to high airflow.
7. Press OK to confirm the change.
8. Press the ►Right key for advancing further and changing the values of K-factor and supply air in air duct 2. (W4.2 only)
9. Press the ◀ Left key twice to return to the Service menu.

Adjust the air damper for extract air and change the value for offset

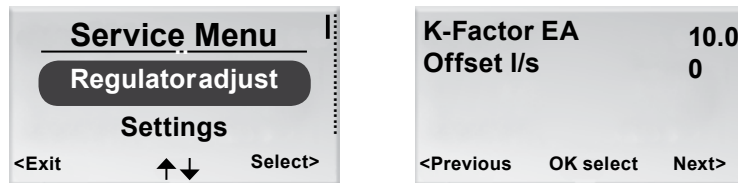

Figure 7. Image for selecting Regulator adjustment settings and image for setting the air damper for extract air and the value for offset.

1. Go to the Service menu.
2. Highlight the Regulator adjustment settings.
3. Press OK or on the ► Right key.
4. Press the ► Right key twice for showing the image for setting the air damper for extract air and offset.
5. Highlight the line of the value you want to change by pressing the ▲ UP key or the ▼ DOWN key.
6. Press OK to highlight the value.
7. Change to desired value.
8. Press OK to confirm the change.
9. Press the ◀ Left key three times to return to the Service menu.

Set the cut-in temperature for cooling and heating

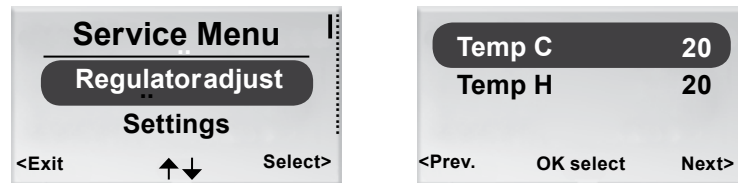

Figure 8. Image for selecting Regulator adjustment settings and image for setting the cut-in temperature for cooling and heating.

1. Go to the Service menu.
2. Highlight the Regulator adjustment settings.
3. Press OK or on the ►Right key.
4. Press the ► Right key three times to show the image for setting the cut-in temperature for cooling and heating.
5. Highlight the line of the value (cooling or heating) you want to change by pressing the ▲ UP or ▼ DOWN key.
6. Press OK to highlight and to be able to change the cut-in temperature.
7. Change the cut-in temperature by pressing the ▲ UP or ▼ DOWN key.
8. Press OK to confirm the change.
9. Press the ◀ Left key four times to return to the Service menu.

View current flows in the air ducts

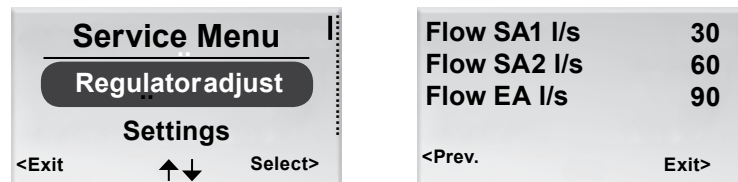

Figure 9. Image for selecting RE settings and image for setting the existing airflows.

1. Go to the Service menu.
2. Highlight the Regulator adjustment settings.
3. Press OK or on the ►Right key.
4. Press the ► Right key four times to show the image for current flows in the supply air ducts and in the extract air duct.
5. Return to the Service menu by pressing the ►Right key.

To change the id number of the room unit.

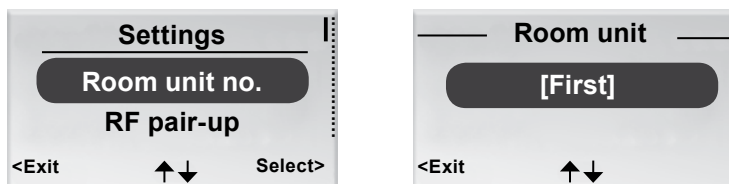

Figure 10. Image for selecting to change the id number of the room unit and the room unit image.

The unit must be assigned an address to enable connecting it up to ModBUS, when the room unit is connected via cable to the controller.

1. Go to the Service menu.
2. Highlight Settings
3. Press OK or on the ►Right key.
4. Highlight the id number of the Room unit.
5. Press OK.
6. Make one of the following selections:
 - Select First whether the room unit is the first one in the room.
 - Select Second if the room unit is the second one in the room.
7. Press OK in order to confirm the selection and return to the Service menu.

Connect units room unit (RU) to controller (RE)

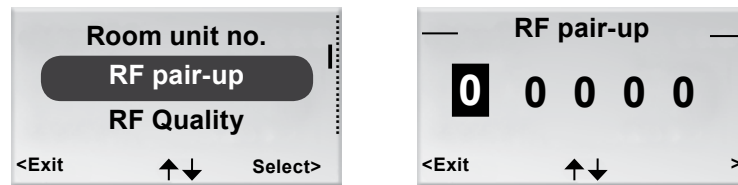

Figure 11. Image for selecting RF pair-up and the RF pair-up image.

The units must be connected together in order to control the controller by means of a hand-held micro terminal. This is done by entering the RF (radio frequency) ID of the controller, which is specified on the identification plate of the controller.

1. Go to the Service menu.
2. Highlight Settings.
3. Press OK or on the ► Right key.
4. Mark Connect units.
5. Press OK or on the ► Right key.
6. Enter the first digit in the RF ID number by pressing the ▲ UP key or ▼ DOWN key.
7. Highlight the next digit position by pressing the ► Right key.
8. Enter the remaining four digits in the RF ID number.
9. Press OK to confirm the RF ID number and connect the room unit to the controller.
If the connection is successful, the text: Connected will be shown.
10. Return to the Settings menu by pressing the ◀ Left key.
11. Return to the Service menu by pressing the ◀ Left key.

RF Quality

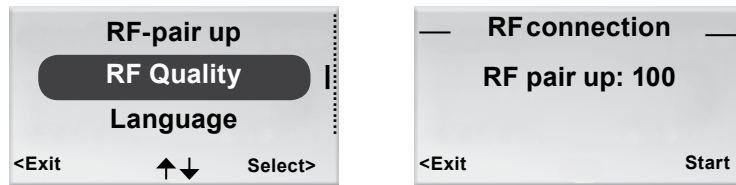

Figure 12. Image for selecting the RF Quality and the RF connection image.

If no cable is connected between the controller and the room unit, the two will communicate with one another via radio signals.

1. Go to the Service menu.
2. Highlight Settings.
3. Press OK or on the ► Right key.
4. Highlight RF pair up
5. Press OK or on the ► Right key.
6. Start the test by the ► Right key.
During the test, 100 messages are sent between the controller and the room unit. The room unit calculates the number of successful transmissions and displays them in the image.
 - The test can be cancelled by pressing the ► Right key.
7. Press the ◀ Left key when the test is finished to return to the Settings menu.
8. Return to the Service menu by pressing the ◀ Left key.

Change language

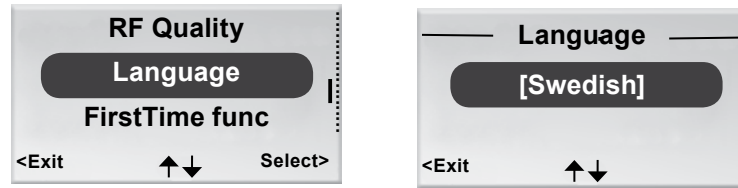

Figure 13. Image for selecting Language and the Language image.

1. Go to the Service menu.
2. Highlight Settings.
3. Press OK or on the ► Right key.
4. To highlight Language.
5. Press OK or on the ► Right key.
6. Select between the languages Swedish, English, Finnish, French and Russian by pressing the ▲ UP or ▼ DOWN key.
7. Press OK in order to confirm the change and return to the Settings menu.
8. Return to the Service menu by pressing the ◀ Left key.

To enable/disable the "first open" function

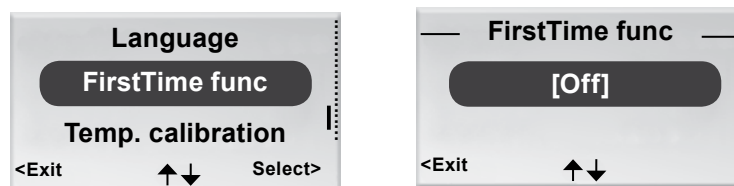

Figure 14. Image for selecting FirstTime function and the FirstTime function image.

1. Go to the Service menu.
2. Highlight Settings.
3. Press OK or on the ► Right key.
4. Highlight FirstTime function.
5. Press OK or on the ► Right key.
6. Enable the function by selecting [On], disable by selecting [Off].
7. Press OK in order to confirm the selection and return to the Settings menu.
8. Return to the Service menu by pressing the ◀ Left key.

Calibrate temperature

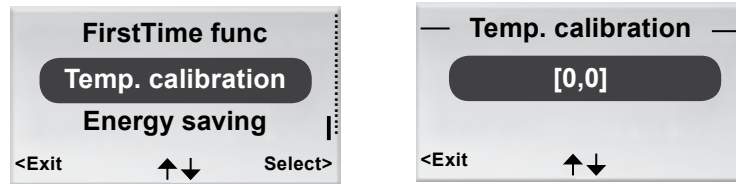

Figure 15. Image for selecting calibrate temperature and the Temp. calibration image .

The purpose of the Calibrate temperature action is to ensure that the temperature reading is in agreement with the actual room temperature.

1. Go to the Service menu.
2. Highlight Settings
3. Press OK or press on the ► Right key..
4. Highlight Temp. calibration.
5. Press OK or on the ► Right key.
6. Change the number of degrees to which the temperature reading should be adjusted.
 - Increase the number of degrees by pressing the ▲ UP key.
 - Decrease the number of degrees by pressing the ▼ DOWN key.
7. Press OK to confirm the calibration and return to the Settings menu.
8. Return to the Service menu by pressing the ◀ Left key.

Energy saving, function to save battery

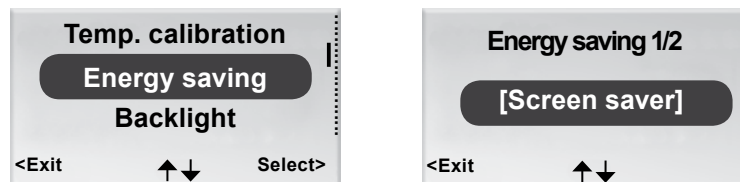

Figure 16. Image for selecting Energy saving and the first Energy saving image.

1. Go to the Service menu.
2. Highlight Settings.
3. Press OK or press on the ► Right key..
4. Highlight Energy saving.
5. Press OK or on the ► Right key.
6. Change the display backlight brightness by pressing the ▲ UP key or the ▼ DOWN key to choose between various alternative settings.
7. Press OK or the key to the right to acknowledge and advance to the spot where you set the backlight duration, if required, by pressing the ▲ UP key or ▼ DOWN key.
8. Press OK to confirm and return to the Settings menu.
9. Return to the Service menu by pressing the ◀ Left key.

Backlight

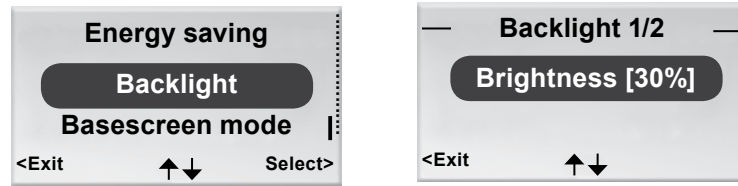

Figure 17. Image for selecting backlight and the backlight function..

1. Go to the Service menu.
2. Highlight Settings.
3. Press OK or the ► Right key.
4. To highlight the Energy-save mode.
5. Press OK or the ► Right key.
6. Change by pressing the ▲ UP key or ▼ DOWN key to choose between backlight brilliance and duration settings
7. Press OK to confirm the change and return to the Settings menu.
8. Return to the Service menu by pressing the ◀ Left key.

Basescreen mode for selecting analogue or digital temperature display



Figure 18. Image for selecting the basescreen mode and image for the Basescreen mode function..

1. Go to the Service menu.
2. Highlight Settings.
3. Press OK or on the ► Right key.
4. Highlight the Basescreen mode.
5. Press OK or the ► Right key.
6. Change by pressing the ▲ UP key or ▼ DOWN key to choose between analogue or digital display.
7. Press OK to confirm the change and return to the Settings menu.
8. Return to the Service menu by pressing the ◀ Left key.

Commissioning

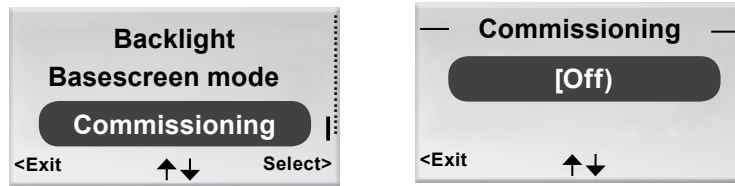

Figure 19. Image for selecting commissioning and image for the Commissioning function.

1. Go to the Service menu.
2. Highlight Settings
3. Press OK or press on the ► Right key..
4. Highlight Commissioning.
5. Press OK or on the ► Right key.
6. Change by pressing the ▲ UP key or ▼ DOWN key to choose between off and on
7. Press OK to confirm the change and return to the Settings menu
8. Return to the Service menu by pressing the ◀ Left key.

Show system information

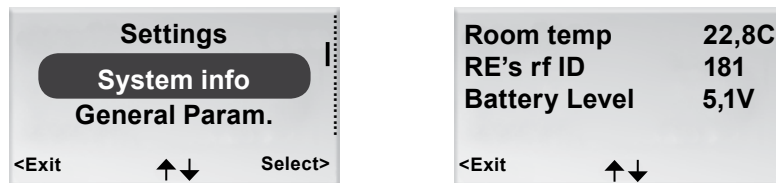
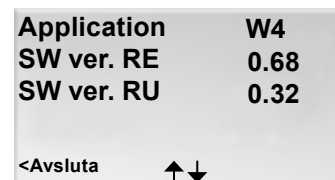

Figure 20. Image for selecting Info and the first image in System information.

1. Go to the Service menu.
2. Highlight Info.
3. Press OK or on the ► Right key.
Current information for the application is shown in the System information images. Navigate between the images by pressing the ▲UP or ▼ DOWN key.
4. Return to the Service menu by pressing the ◀ Left key.



Change parameters

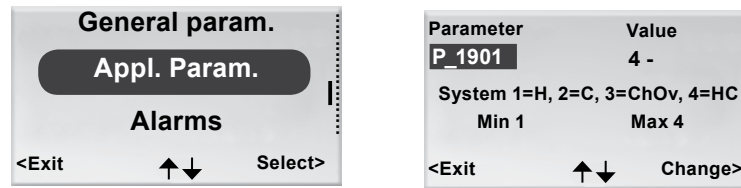

Figure 21. Image for selecting changes in the application parameters and typical parameter image.

1. Go to the Service menu.
2. Depending on which parameters you want to change, highlight the appropriate General parameter or Application parameter.
3. Press OK or on the ► Right key.
4. Enter the authorization code for General parameters or Application parameters.
5. Select the parameter to be altered by pressing the ▲ UP or ▼ DOWN key.
6. Highlight the value by pressing the ► Right key.
7. Change the value by pressing the ▲ UP or ▼ DOWN key.
8. Press OK to confirm the new value.
9. Press the ◀ Left key to exit the parameter change image.
10. Highlight:
 - Yes to save the changes you've made.
 - No to not to save the changes.
 - Cancel to return to parameter change image.
11. Press OK to return to the Service menu.

Show Alarms

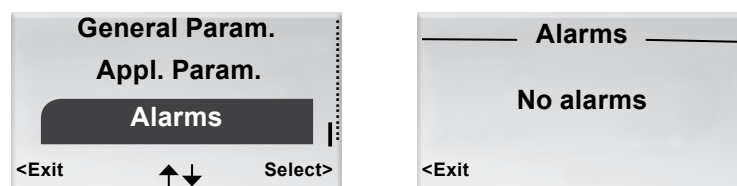

Figure 22. Image for selecting Show Alarms and the Alarm image.

1. Go to the Service menu.
2. Highlight Alarms.
3. Press OK or on the ► Right key.
All active alarms are shown in the image.
4. Return to the Service menu by pressing the ◀ Left key.

Service

This section is intended only for use by personnel who are specially trained by Swegon.

Parameters

In order to control the functions in the CONDUCTOR W4, there are a number of parameters, which can be changed in order to optimize the current installation. In the display of the room unit (thermostat) every parameter is shown in accordance with the figure below.

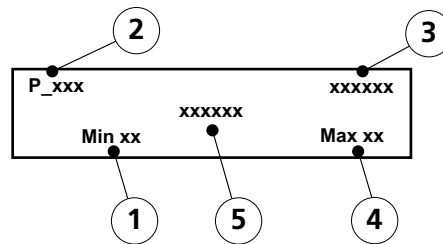

Figur 1. Main image in the display of the room unit.

- Pos 1. Minimal value.
- Pos 2. Parameter number.
- Pos 3. Factory-preset value
- Pos 4. Maximum value.
- Pos 5. Parameter text.

System parameters

System parameters are basic parameters which are common for several applications.

Display image	Description															
<table border="1" style="width: 100%;"> <tr> <td style="width: 20%;">P_101</td> <td style="width: 40%;"></td> <td style="width: 10%; text-align: right;">set</td> <td style="width: 10%; text-align: right;">2</td> <td style="width: 10%; text-align: right;">ID</td> </tr> <tr> <td></td> <td style="text-align: center;">Modbus Address</td> <td></td> <td></td> <td></td> </tr> <tr> <td>min</td> <td style="text-align: right;">1</td> <td></td> <td></td> <td style="text-align: right;">max 247</td> </tr> </table>	P_101		set	2	ID		Modbus Address				min	1			max 247	Indicates the ModBus address.
P_101		set	2	ID												
	Modbus Address															
min	1			max 247												
<table border="1" style="width: 100%;"> <tr> <td style="width: 20%;">P_102</td> <td style="width: 40%;"></td> <td style="width: 10%; text-align: right;">set</td> <td style="width: 10%; text-align: right;">3</td> <td></td> </tr> <tr> <td></td> <td style="text-align: center;">BMS Baudrate, 9.6 19.2 38.4</td> <td></td> <td></td> <td></td> </tr> <tr> <td>min</td> <td style="text-align: right;">1</td> <td></td> <td></td> <td style="text-align: right;">max 3</td> </tr> </table>	P_102		set	3			BMS Baudrate, 9.6 19.2 38.4				min	1			max 3	Indicates the transmission speed for connecting up to a Building Management System (BMS). 1 = 9.6 2 = 19.2 3 = 38.4
P_102		set	3													
	BMS Baudrate, 9.6 19.2 38.4															
min	1			max 3												
<table border="1" style="width: 100%;"> <tr> <td style="width: 20%;">P_103</td> <td style="width: 40%;"></td> <td style="width: 10%; text-align: right;">set</td> <td style="width: 10%; text-align: right;">2</td> <td></td> </tr> <tr> <td></td> <td style="text-align: center;">BMS Parity 0=Od. 1=Ev. 2=None</td> <td></td> <td></td> <td></td> </tr> <tr> <td>min</td> <td style="text-align: right;">0</td> <td></td> <td></td> <td style="text-align: right;">max 2</td> </tr> </table>	P_103		set	2			BMS Parity 0=Od. 1=Ev. 2=None				min	0			max 2	Parity setting for connection to BMS. 0 = Uneven 1 = Even 2 = None
P_103		set	2													
	BMS Parity 0=Od. 1=Ev. 2=None															
min	0			max 2												
<table border="1" style="width: 100%;"> <tr> <td style="width: 20%;">P_104</td> <td style="width: 40%;"></td> <td style="width: 10%;"></td> <td style="width: 10%; text-align: right;">1</td> <td></td> </tr> <tr> <td></td> <td style="text-align: center;">BMS Stop bits</td> <td></td> <td></td> <td></td> </tr> <tr> <td>min</td> <td style="text-align: right;">1</td> <td></td> <td></td> <td style="text-align: right;">max 2</td> </tr> </table>	P_104			1			BMS Stop bits				min	1			max 2	Number of stop bits for connection to BMS. 1 = 1 bit 2 = 2 bits
P_104			1													
	BMS Stop bits															
min	1			max 2												
<table border="1" style="width: 100%;"> <tr> <td style="width: 20%;">P_105</td> <td style="width: 40%;"></td> <td style="width: 10%;"></td> <td style="width: 10%; text-align: right;">3</td> <td></td> </tr> <tr> <td></td> <td style="text-align: center;">Component type, 2=DC, 3=RC</td> <td></td> <td></td> <td></td> </tr> <tr> <td>min</td> <td style="text-align: right;">2</td> <td></td> <td></td> <td style="text-align: right;">max 3</td> </tr> </table>	P_105			3			Component type, 2=DC, 3=RC				min	2			max 3	Indicates the current type of controller.
P_105			3													
	Component type, 2=DC, 3=RC															
min	2			max 3												

Display image	Description
<p>P_106 2</p> <p>Application type</p> <p>min 1 max 14</p>	Indicates which application the controller is set to run. 10 = W4
<p>P_107 1</p> <p>Relay at emer. 0=Op. 1=Cl. 2=No act.</p> <p>min 0 max 2</p>	Indicates the status of the relay for the EMERG mode. 0 = Open 1 = Closed 2 = No action
<p>P_108 48 hour</p> <p>Valve exercise (h) 0=Not used</p> <p>min 0 max 96</p>	Indicates how often the valves should be exercised (how many hours shall pass between two exercise runs).
<p>P_109 20 min</p> <p>Motion timer delay (min)</p> <p>min 0 max 60</p>	Indicates the number of minutes after which the controller should switch from AUTO to ECON after the last occupant has left the room.
<p>P_110 60 min</p> <p>Warning delay from start-up (min)</p> <p>min 0 max 720</p>	Indicates the number of minutes after which the controller shall be permitted to initiate an alarm following a start up.
<p>P_111 120 min</p> <p>Warning delay, PI-overload (min)</p> <p>min 0 max 720</p>	Indicates the number of minutes after which the system should initiate an alarm for a +100% or -100% output signal.
<p>P_112 120 min</p> <p>Warning delay, Set point (min)</p> <p>min 0 max 720</p>	Indicates the number of minutes after which the system should initiate an alarm, if the temperature, flow or pressure setpoint has not been reached.
<p>P_113 30 min</p> <p>Warning delay, pressure sensor (min)</p> <p>min 0 max 720</p>	Indicates the number of minutes after which the system should initiate an alarm if no signal is received from the pressure sensor or flow sensor
<p>P_114 0</p> <p>Room Number (optional)</p> <p>min 0 max 32000</p>	Indicates the room number.
<p>P_118 0 h</p> <p>Zero calibration (h) 0=not used</p> <p>min 0 max 720</p>	O-point calibration of MB pressure sensor. Enter hours between calibration.
<p>P_119 3 min</p> <p>Zero calibration wait (min)</p> <p>min 1 max 6</p>	Delay before calibration starts. (to allow the dampers time to close)
<p>P_120 set 2 ID</p> <p>BMS Modbus Address</p> <p>min 1 max 247</p>	Modbus address for the pipe work contractor in BMS mode (Modbus 1)

Application parameters

Application parameters are parameter-specific for the selected application.

Display image	Description
<p>P_1901 4</p> <p style="text-align: center;">System, 1=He, 2=Co, 3=ChOv, 4=HC</p> <p>Min 1 Max 4</p>	<p>Indicates how the climate system should operate for heating and cooling.</p> <p>1 = Heating only 2 = Cooling only 3 = Change-over function 4 = Heating/Cooling</p>
<p>P_1902 1</p> <p style="text-align: center;">0=ext.temp, 1 or 2 room units</p> <p>Min 0 Max 2</p>	<p>Indicates whether one or two room units are used. If 2 units are used they should be connected with a cable.</p> <p>0 = ext.temp, 1 = 1 unit 2 = 2 units</p>
<p>P_1903 10 °C</p> <p style="text-align: center;">Frost guard temp</p> <p>Min 5 Max 12</p>	<p>Indicates at which temperature the frost protection should switch in.</p>
<p>P_1904 1</p> <p style="text-align: center;">Economy mode available?</p> <p>Min 0 Max 1</p>	<p>Indicates whether the Economy mode is available.</p> <p>0 = No 1 = Yes</p>
<p>P_1907 18 °C</p> <p style="text-align: center;">Night cool, Set point</p> <p>Min 10 Max 32</p>	<p>Indicates the temperature setpoint applicable to the Night cool function.</p>
<p>P_1908 1</p> <p style="text-align: center;">Actuator Cool, 1=NC, 2=0-10V, 3=NO</p> <p>Min 1 Max 3</p>	<p>Indicates which sort of valve actuator is installed in the cooling water circuit.</p> <p>1 = Normally closed 2 = 0-10V 3 = Normally open</p>
<p>P_1909 0</p> <p style="text-align: center;">Window, 0=NP, 1=NC, 2=NO</p> <p>Min 0 Max 2</p>	<p>Indicates whether a window contact is installed and if so how it is installed.</p> <p>0 = No contact installed 1 = Normally closed 2 = Normally open</p>
<p>P_1910 0</p> <p style="text-align: center;">Occupancy, 0=NP, 1=NC, 2=NO</p> <p>Min 0 Max 2</p>	<p>Indicates whether a presence detector is installed and if so how it is installed.</p> <p>0 = No contact installed 1 = Normally closed 2 = Normally open</p>
<p>P_1911 480 min</p> <p style="text-align: center;">RU back to auto state</p> <p>Min 0 Max 1200</p>	<p>Indicates how long after the most recent manual room temperature adjustment that the controller should return to the AUTO mode.</p> <p>0 = Not used</p>
<p>P_1912 16 °C</p> <p style="text-align: center;">Room unit's min set point</p> <p>Min 10 Max 22</p>	<p>Indicates which lowest temperature is possible to adjust manually on the room unit in the MAN operating mode.</p>

Display image	Description
P_1913 28 °C Room unit's max set point Min 23 Max 32	Indicates which highest temperature is possible to adjust manually on the room unit in the MAN operating mode.
P_1914 10 % Heat ON limit Min 5 Max 50	Indicates at which output signal for heating the relay contact closes and the heat source is opened.
P_1915 10 % Heat OFF limit Min 5 Max 10	Indicates at which output signal for heating the relay contact opens and the heat source is disconnected.
P_1916 5 min Delay between heat ON/OFF Min 1 Max 25	Indicates what the delay should be between when the heat source is connected or disconnected. The purpose of this is to prevent the relay contact from closing and opening too often.
P_1917 5000 P term Heating Scale 1:100 Min 1 Max 10000	Indicates the value for P for heating. A high value denotes faster control. A low value denotes slower control.
P_1918 3 I term Heating Scale 1:100 Min 1 Max 10000	Indicates the value for I for heating. A high value denotes faster control. A low value denotes slower control.
P_1919 7000 P term Cooling Scale 1:100 Min 1 Max 10000	Indicates the value for P for cooling. A high value denotes faster control. A low value denotes slower control.
P_1920 5 I term Cooling Scale 1:100 Min 1 Max 10000	Indicates the value for I for cooling. A high value denotes faster control. A low value denotes slower control.
P_1921 5000 P term Change over Min 1 Max 10000	Indicates the value for P for the Change Over function. A high value denotes faster control. A low value denotes slower control.
P_1922 5 I term Change over Min 1 Max 10000	Indicates the value for I for the Change Over function. A high value denotes faster control. A low value denotes slower control.
P_1923 0 CO2 Control, 0=No, 1=Active Min 0 Max 1	Indicates whether the installed carbon dioxide sensor is connected or not. 0 = Not connected 1 = Connected
P_1924 500 ppm CO2 min level ppm Min 350 Max 1000	Indicates at which lowest carbon dioxide content in the room the airflow should increase.

Display image	Description
<p>P_1925 1000 ppm</p> <p style="text-align: center;">CO2 max level ppm</p> <p>Min 350 Max 2000</p>	Indicates at which carbon dioxide content in the room the airflow should be increased to the highest flow.
<p>P_1926 200 ppm/volt</p> <p style="text-align: center;">ppm CO2 / Volt</p> <p>Min 10 Max 500</p>	Indicates how the controller converts the CO ₂ signal to an 0-10V output signal. Example: At 200ppm/Volt, 800ppm will produce a 4V output signal.
<p>P_1927 0</p> <p style="text-align: center;">Emergency func, SA mode</p> <p>Min 0 Max 1</p>	Indicates which blade position the damper in the supply air duct should have in event of fire. 0 = Closed 1 = Open
<p>P_1928 0</p> <p style="text-align: center;">Emergency func, EA damper</p> <p>Min 0 Max 1</p>	Indicates which blade position the damper in the extract air duct should have in event of fire. 0 = Closed 1 = Open
<p>P_1929 2</p> <p style="text-align: center;">SA1 Flow sen, 0=NP, 1=Ana, 2=MB</p> <p>Min 0 Max 2</p>	Indicates whether pressure sensor in supply air duct 1 is connected and if so of what type. 0 = No sensor connected. 1 = Analogue sensor. 2 = ModBus.
<p>P_1930 0</p> <p style="text-align: center;">SA2 Flow sen, 0=NP, 1=Active</p> <p>Min 0 Max 1</p>	Indicates whether the pressure sensor in supply air duct 2 is connected. 0 = No sensor connected. 1 = Sensor connected.
<p>P_1931 0</p> <p style="text-align: center;">EA Flow sen, 0=NP, 1=Active</p> <p>Min 0 Max 1</p>	Indicates whether the pressure sensor is connected in the extract air duct. 0 = No sensor connected. 1 = Sensor connected.
<p>P_1932 1</p> <p style="text-align: center;">Reg. sequence, 0=A-W, 1=W-A</p> <p>Min 0 Max 1</p>	Indicates the sequence according to which the controller should manage air and water. 0 = Air - Water 1 = Water - Air
<p>P_1933 20 l/s</p> <p style="text-align: center;">Normal flow SA1 (l/s)</p> <p>Min 0 Max 1000</p>	Indicates which normal flow in supply air duct 1 should be set, in the AUTO operating mode.
<p>P_1934 30 l/s</p> <p style="text-align: center;">Boost flow SA1 (l/s)</p> <p>Min 0 Max 2500</p>	Indicates which flow in supply air duct 1 should be set for BOOST.
<p>P_1935 90 l/s</p> <p style="text-align: center;">Boost flow SA2 (l/s)</p> <p>Min 0 Max 2500</p>	Indicates which flow in supply air duct 2 that should be set for BOOST.
<p>P_1936</p>	Parameter not used.

Display image	Description
<p>P_1937 0 l/s</p> <p>Offset flow EA (l/s)</p> <p>Min -100 Max 100</p>	Indicates the offset flow in the extract air duct.
<p>P_1938 20 %</p> <p>Economy flow, % from Normal flow</p> <p>Min 0 Max 100</p>	Indicates how large portion of the normal flow that should be economy flow.
<p>P_1939 5 Pa</p> <p>Min SA1 Pressure (Pa)</p> <p>Min 5 Max 100</p>	Indicates what the lowest pressure could be in supply air duct 1, in order to ensure the function.
<p>P_1940 0 mV</p> <p>SA1 mV at 0% output</p> <p>Min 0 Max 5000</p>	Indicates the Volt signal transmitted to the actuator on a 0% output signal from the controller. Resolution = 50 mV
<p>P_1941 10000 mV</p> <p>SA1 mV at 100% output</p> <p>Min 5000 Max 10000</p>	Indicates the Volt signal transmitted to the actuator on a 100% output signal from the controller. Resolution = 50 mV
<p>P_1942 0 mV</p> <p>SA2 mV at 0% output</p> <p>Min 0 Max 5000</p>	Indicates the Volt signal transmitted to the actuator on a 0% output signal from the controller. Resolution = 50 mV
<p>P_1943 10000 mV</p> <p>SA2 mV at 100% output</p> <p>Min 5000 Max 10000</p>	Indicates the Volt signal transmitted to the actuator on a 100% output signal from the controller. Resolution = 50 mV
<p>P_1944 0 mV</p> <p>EA mV at 0% output</p> <p>Min 0 Max 5000</p>	Indicates the Volt signal transmitted to the actuator on a 0% output signal from the controller. Resolution = 50 mV
<p>P_1945 10000 mV</p> <p>EA mV at 100% output</p> <p>Min 5000 Max 10000</p>	Indicates the Volt signal transmitted to the actuator on a 100% output signal from the controller. Resolution = 50 mV
<p>P_1946 50 %</p> <p>SA1 damper after sensor error</p> <p>Min 0 Max 100</p>	Displays start position on supply air 1 after an error on the sensor.
<p>P_1947 10 %</p> <p>SA2 damper after sensor error</p> <p>Min 0 Max 100</p>	Indicates the start position on supply air 2 after an error on the sensor.
<p>P_1948 50 %</p> <p>EA damper after sensor error</p> <p>Min 0 Max 100</p>	Indicates start position on the extract air after an error on the sensor.

Display image	Description
<p>P_1949 150</p> <p>P term SA1 Scale 1:100</p> <p>Min 1 Max 10000</p>	Indicates the value for P in supply air duct 1. A high value denotes faster control. A low value denotes slower control.
<p>P_1950 50</p> <p>I term SA1 Scale 1:100</p> <p>Min 1 Max 10000</p>	Indicates the value for I in supply air duct 1. A high value denotes faster control. A low value denotes slower control.
<p>P_1951 150</p> <p>P term SA2 Scale 1:100</p> <p>Min 1 Max 10000</p>	Indicates the value for P in supply air duct 2. A high value denotes faster control. A low value denotes slower control.
<p>P_1952 50</p> <p>I term SA2 Scale 1:100</p> <p>Min 1 Max 10000</p>	Indicates the value for I in supply air duct 2. A high value denotes faster control. A low value denotes slower control.
<p>P_1953 150</p> <p>P term EA Scale 1:100</p> <p>Min 1 Max 10000</p>	Indicates the value for P in the extract air duct. A high value denotes faster control. A low value denotes slower control.
<p>P_1954 50</p> <p>I term EA Scale 1:100</p> <p>Min 1 Max 10000</p>	Indicates the value for I in the extract air duct. A high value denotes faster control. A low value denotes slower control.
<p>P_1955 1</p> <p>SA1 calc. type, 1=Ana, 2=MB</p> <p>Min 1 Max 2</p>	Indicates how the controller calculates the airflow in supply air duct 1 in relation to the C-factor. 1=Linear Analogue pressure sensors 2=Quadratic of MB pressure sensor.
<p>P_1956 50</p> <p>SA1 K-term, Scale 1:10</p> <p>Min 1 Max 15000</p>	Indicates the C-factor for actuator downstream of supply air duct 1. Resolution = 1:10
<p>P_1957 2</p> <p>SA2 calc. type, 2=MB</p> <p>Min 2 Max 2</p>	Indicates how the controller calculates the airflow in supply air duct 2 in relation to the C-factor. 2=Quadratic of MB pressure sensor.
<p>P_1958 50</p> <p>SA2 K-term, Scale 1:10</p> <p>Min 1 Max 15000</p>	Indicates the C-factor for supply air duct 2.
<p>P_1959 2</p> <p>EA calc. type, 2=MB</p> <p>Min 2 Max 2</p>	Indicates how the controller calculates the airflow in the extract air duct in relation to the C-factor. 2 = Quadratic of the MB pressure sensor.
<p>P_1960 50</p> <p>EA K-term, Scale 1:10</p> <p>Min 1 Max 15000</p>	Indicates the C-factor for the extract air duct.

Display image	Description
<p>P_1961 2</p> <p>Actuator Heat 1=NO, 2=NC (On Relay, X-15)</p> <p>Min 1 Max 2</p>	<p>Indicates the type of valve actuators that are used to heat water</p> <p>1=24V-NC 2=24V-NO</p>
<p>P_1962 0</p> <p>Boost at arrival 0=No 1=Active</p> <p>Min 0 Max 1</p>	<p>Indicates whether time-adjusted flow boost is accessible. (0=No, 1=Yes)</p>
<p>P_1963 5</p> <p>Boost at arrival time (min)</p> <p>Min 1 Max 300</p>	<p>Indicates how long the timeadjusted flow boost should be on ON when occupancy is activated</p>
<p>P_1964 2</p> <p>Conference or Office</p> <p>Min 1 Max 2</p>	<p>Select function. Conference room (two supply air dampers) or hotel/office</p> <p>1=W4.2 (Conference room) 2=W4.1 (Hotel)</p>
<p>P_1965 1</p> <p>ActuatorHeat 1=NC, 2=0-10V, 3=NO (30-31-32, X-12)</p> <p>Min 1 Max 3</p>	<p>W4.1 function for actuator, heat</p> <p>1= Normally closed 2= 0-10V 3= Normally open</p>
<p>P_1966 23</p> <p>TC_Normal</p> <p>Min 15 Max 30</p>	<p>Switch in cooling for normal operation.</p>
<p>P_1967 21</p> <p>TH_Normal</p> <p>Min 15 Max 30</p>	<p>Switch in heating for normal operation.</p>
<p>P_1968 25</p> <p>TC_Economy</p> <p>Min 10 Max 30</p>	<p>Switch in cooling for economic operation.</p>
<p>P_1969 19</p> <p>TH_Economy</p> <p>Min 10 Max 30</p>	<p>Switch in heating for economic operation.</p>
<p>P_1970 27</p> <p>TC_Holiday</p> <p>Min 10 Max 30</p>	<p>Switch in cooling for holiday operation.</p>
<p>P_1971 17</p> <p>TH_Holiday</p> <p>Min 10 Max 30</p>	<p>Switch in heating for holiday operation.</p>

Indication on the controller

There are two indicating LEDs on the controller, one on the front (No.1) and under the lid (No.2). The indications that can be shown, their importance and their relation to the DIP switches (DIP) is as follows:

No.	1st	2nd	DIP 1	DIP 2	Explanation	Remarks
1.	Green flashing for 1 second.	None.	Off.	Off.	Normal operation.	-
2.	Red and green flashing.	None.	Off.	Off.	Normal operation, but: The room unit or pressure sensor is missing. The temperature sensor in the room unit is defective. KTY sensor missing.	-
3.	Red flashing for 1 second.	None.	Off.	Off.	External memory error. AC output signals are incorrect. MB-ID = 0 or higher than 247.	X1 and X2 are "slaves" and X3 is a "master". MB-ID is 1. Set DIP 1 and DIP 2 to On.
4.	Orange flashing for 1 second.	None.	On.	Off.	Service position.	All MB ports are "slaves", 38400n1. Room unit does not operate in the service mode.
5.	-	-	Off.	On.	BMS mode.	The mode is automatically activated when required.
6.	Light orange.	Light orange.	-	-	The controller lacks bootloader or is in reset.	-
7.	Green.	Green.	-	-	The controller has bootloader but lacks software.	MB-ID is same as in the parameter file.
8.	Orange.	Green.	On.	-	The controller has bootloader but lacks software.	MB-ID is forced to 1.
9.	Fast green flashing.	Green.	-	-	The parameter file is being processed.	See to it that the power supply is maintained.
10.	-	Red.	-	-	The voltage is low (Supply voltage is <13V).	Safety measure for the AC output signals. All signals are Off.
11.	-	Very rapid green flashing.	-	-	Radio Frequency communication.	-
12.	-	Very rapid red flashing.	-	-	Further transmission of MB.	-

Trouble shooting

An alarm is initiated when an error arises in the control system. There are two types of alarms:

- General alarms.
- Application alarms.

Trouble shooting of the control system should always begin with investigating whether any alarm has been initiated and if so which.

Certain alarms are automatically reset (Auto) after the cause of the error has been remedied, while other alarms have to be manually (Man) reset.

If the control system is connected to a ModBus system, the alarms can be read within the 10100 – 10139 range.

Alarm No.	Alarm text	Description / Cause	Remedial measure	Resetting
0.	No active alarms	No active alarms present.	No measure required.	-
1.	No room unit 1	The controller has not received any signal from the room unit 1 within the given time (P_110).	Make a new connection – Radio Frequency mode. Check the cable.	Auto
2.	No room unit 2	The controller has not received any signal from the room unit 2 within the given time (P_110).	Check the cable.	Auto
3.	No pressure sensor	Pressure sensor is missing or is defective. Alarm is initiated after given time (P_113).	Install or replace the sensor.	Auto
4.	No supply flow sensor	Flow sensor is missing or is defective. Alarm is initiated after given time (P_113).	Install or replace the sensor.	Auto
5.	No exhaust flow sensor	Flow sensor is missing or is defective. Alarm is initiated after given time (P_113).	Install or replace the sensor.	Auto
6.	Room unit 1 temperature	No temperature from room unit 1.	Change room unit!	Auto
7.	Room unit 2 temperature	No temperature from room unit 2.	Change room unit!	Auto
8.	Controller KTY short circuit	KTY sensor defective.	Replace the KTY sensor.	Auto
9.	Controller KTY open circuit	KTY sensor missing.	Check connection of the KTY sensor.	Auto
10.	Room unit low battery	The level on the battery in the room unit is low.	Replace the batteries in the room unit!	Auto
11.	PT-controller overload	The output signal has been +100% or -100% during the given time (P_111).	Check water the temperature and the water flow.	Auto
12.	Set point not reached	Set temperature, set flow or pressure has not been reached within given time (P_112).	Check the water temperature, the water flow and the airflow.	Auto
13.	TBD	-	-	-
14.	TBD	-	-	-
15.	No device list	-	-	-
16.	AC overload	The supply voltage is too high.	Check the voltage source.	Auto
17.	System fault	Component error.	Replace the controller!	-
18.	No serial number	Program error.	Replace the controller!	-

Alarm No.	Alarm text	Description / Cause	Remedial measure	Resetting
19.	TBD	-	-	-
20.	Short circuit X11	Connected component is defective.	Troubleshoot to find the faulty component and replace the component.	Man.
21.	Short circuit X12	Connected component is defective.	Troubleshoot to find the faulty component and replace the component.	Man.
22.	Short circuit X13	Connected component is defective.	Troubleshoot to find the faulty component and exchange the component.	Man.
23.	Short circuit X14	Connected component is defective.	Troubleshoot to find the faulty component and exchange the component.	Man.
24.	SPI flash broken	Component error.	Replace the controller!	Man.
25.	Radio chip broken	Component error.	Replace the controller!	Man.
26.	Parameter file revision	Parameter file is incorrect.	Update with new parameter file.	Man.
27.	Parameter file format	Parameter file is incorrect.	Update with new parameter file.	Man.
28.	No Modbus ID	Parameter file is incorrect.	Update with new parameter file.	Man.
29.	No application	Parameter file is incorrect.	Update with new parameter file.	Man.
30.	No parameters	Parameter file is incorrect.	Update with new parameter file.	Man.
31.	Parameter missing	Parameter file is incorrect.	Update with new parameter file.	Man.
32.	Parameter value error	Parameter file is incorrect.	Update with new parameter file.	Man.
33.	Parameter file size	Parameter file is incorrect.	Update with new parameter file.	Man.
34.	Wrong parameter file	Parameter file is incorrect.	Update with new parameter file.	Man.
35.	Check duct group SM	-	-	-
36.	Check duct group DC	-	-	-
37.	Previous parameters are lost	Changes in parameter file has been lost.	To restart the controller.	Man.
38.	Factory parameters take up	Changes in parameter file have not been approved.	To restart the controller.	Man.
39.	TBD	-	-	-
40.	TBD	-	-	-
41.	No supply pressure from AHU	-	-	-
42.	No exhaust pressure from AHU	-	-	-
43.	Supply duct 100% open	-	-	-
44.	Exhaust duct 100% open	-	-	-
45.	Low voltage detect	The voltage for the controller is low.	Check the voltage source.	Auto
46.	TBD	-	-	-
47.	Duct group member missing	-	-	-
48.	Negative pressure	-	-	-

Modbus register

The information listed below applies when the CONDUCTOR W4 is connected to a so-called ModBus system.

Conductor W4 BMS, applies to software from 0.76

Default values from parameter file

Coil Status	Discrete Output (1 bit)	R/W		
Modbus	Name	Min/Max	Remarks	Default
0x0001	Not used			
0x0002	SA Emergency action	0/1		0
0x0003	EA Emergency action	0/1		0
0x0004	Not used			
0x0005	Economy mode	0/1	0=Unavailable, 1= Available	1
0x0006	Not used			
0x0007	Not used			

Input Status	Discrete Input (1 bit)	Read only		
Modbus	Name	Min/Max	Remarks	Default
1x0001	Condensation	0/1		
1x0002	Relay state	0/1		
1x0003	Occupancy switch	0/1		
1x0004	Window switch	0/1		
1x0005	Motion	0/1		
1x0006	Active alarms	0/1	Number of alarms	
1x0007	No Room Unit 1	0/1	ALARM, resets automatically	
1x0008	No Room Unit 2	0/1	ALARM, resets automatically	
1x0009	No Pressure sensor	0/1	ALARM, resets automatically	
1x0010	No Supply Flow sensor	0/1	ALARM, resets automatically	
1x0011	No Exhaust Flow sensor	0/1	ALARM, resets automatically	
1x0012	Room Unit 1 Temperature	0/1	ALARM, resets automatically	
1x0013	Room Unit 2 Temperature	0/1	ALARM, resets automatically	
1x0014	Regulator KTY short circuit	0/1	ALARM, resets automatically	
1x0015	Regulator KTY open circuit	0/1	ALARM, resets automatically	
1x0016	Room Unit Low Battery	0/1	ALARM, resets automatically	
1x0017	PI-controller overload	0/1	ALARM, resets automatically	
1x0018	Setpoint not reached	0/1	ALARM, resets automatically	
1x0019	Not used			
1x0020	Not used			
1x0021	No device list	0/1	ALARM, resets automatically	
1x0022	AC overload	0/1	ALARM, resets automatically	
1x0023	System fault	0/1	ALARM	
1x0024	No serial number	0/1	ALARM	
1x0025	Not used			
1x0026	Short circuit X11	0/1	ALARM, requires HW reset	
1x0027	Short circuit X12	0/1	ALARM, requires HW reset	
1x0028	Short circuit X13	0/1	ALARM, requires HW reset	

Conductor W4 BMS, applies to software from 0.76

Default values from parameter file

Input Status	Discrete Input (1 bit)	Read only		
Modbus	Name	Min/Max	Remarks	Default
1x0029	Short circuit X14	0/1	ALARM, requires HW reset	
1x0030	SPI Flash broken	0/1	ALARM, requires HW reset	
1x0031	Radio chip broken	0/1	ALARM, requires HW reset	
1x0032	Parameter file revision	0/1	ALARM, requires HW reset	
1x0033	Parameter file format	0/1	ALARM, requires HW reset	
1x0034	No ModBus ID	0/1	ALARM, requires HW reset	
1x0035	No Application	0/1	ALARM, requires HW reset	
1x0036	No parameters	0/1	ALARM, requires HW reset	
1x0037	Parameter missing	0/1	ALARM, requires HW reset	
1x0038	Parameter value error	0/1	ALARM, requires HW reset	
1x0039	Parameter file size	0/1	ALARM, requires HW reset	
1x0040	Wrong parameter file	0/1	ALARM, requires HW reset	
1x0041	Check Duct Group SM	0/1	ALARM, resets after right parameters	
1x0042	Check Duct Group DC	0/1	ALARM, resets after right parameters	
1x0043	Previous parameters are lost	0/1	ALARM, requires HW reset	
1x0044	Factory parameters take up	0/1	ALARM, requires HW reset	
1x0045	Not used			
1x0046	Not used			
1x0047	No supply pressure from AHU	0/1	ALARM, resets automatically	
1x0048	No exhaust pressure from AHU	0/1	ALARM, resets automatically	
1x0049	Supply duct 100% open	0/1	ALARM, resets automatically	
1x0050	Exhaust duct 100% open	0/1	ALARM, resets automatically	
1x0051	Low voltage detect	0/1	ALARM, resets automatically	
1x0052	Not used			
1x0053	Duct group member missing	0/1	ALARM, resets automatically	
1x0054	Negative pressure	0/1	ALARM, resets automatically	

Holding register	16 bit integer register	RW		
Modbus	Name	Min/Max	Remarks	Default
4x0001	Relay in Emergency	0/1	0=Close, 1=Open, 2=No Action	1
4x0002	Application transition	1/9	1=Auto Normal, 2=Economy, 3=Manual, 4=Stand-by, 5=Emergency, 6=Night Cool, 7=Timer-function, 9=Not used Some of these requires that window and occupancy parameter is set to 0=NP	
4x0003	Room number		Value can be 0-32000	0
4x0004	Valve exercise	0/72	Valve exercise 0=Not used (hours)	48
4x0005	Motion Timer	0/20	Motion timer (minutes)	20
4x0006	General warning time	0/60	Warning delay, general (minutes)	60
4x0007	PI-overload warning time	0/60	Warning delay, PI-overload (minutes)	120
4x0008	Set-point warning time	0/60	Warning delay, Set point (minutes)	60
4x0009	Pressure sensor warning time	0/60	Warning delay, pressure sensor (minutes)	15
4x0010	Not used			

Conductor W4 BMS, applies to software from 0.76

Default values from parameter file

Holding register 16 bit integer register RW

Modbus	Name	Min/Max	Remarks	Default
4x0011	Not used			
4x0012	Not used			
4x0013	Not used			
4x0014	System type	1/4	1= Heat, 2= Cool, 3= Change Over, 4=Heat+Cool	4
4x0015	Number of Room units	1/2	1=One room unit, 2= Two room units	1
4x0016	Window switch	0/2	0=Not used 1=Normaly Closed 2=Normaly Open	1
4x0017	Occupancy switch	0/2	0=Not used 1=Normaly Closed 2=Normaly Open	1
4x0018	Actuator Type Cool	1/3	ActuatorCool 1=NC,2=0-10V,3=NO	1
4x0019	Not used			
4x0020	Not used			
4x0021	TC Not used	10/30	(degC)	27
4x0022	TH Not used	10/30	(degC)	17
4x0023	Frost guard temp.	5/15	(degC)	10
4x0024	TC1 Normal	15/30	(degC)	23
4x0025	TH1 Normal	15/30	(degC)	21
4x0026	TC2 Economy	10/30	(degC)	25
4x0027	TH2 Economy	10/30	(degC)	19
4x0028	Night cool setpoint	10/20		18
4x0029	Room unit's min set point	0/20	only when room unit is manual state (degC)	16
4x0030	Room unit's max set point	25/50	only when room unit is manual state (degC)	28
4x0031	Not used			
4x0032	Not used			
4x0033	Not used			
4x0034	Not used			
4x0035	RU back to auto state	0/1200	Time when room unit come back from manual state to auto	480
4x0036	Normal flow SA1	0/1000	l/s	20
4x0037	Not used			
4x0038	Economy flow from Normal	0/100	(%)	20
4x0039	Not used flow from Normal	0/100	(%)	10
4x0040	Not used			
4x0041	Not used			
4x0042	Boost flow SA1	0/2500	l/s	30
4x0043	Boost flow SA2	0/2500	l/s	30
4x0044	Not used			
4x0045	Not used			

Conductor W4 BMS, applies to software from 0.76

Default values from parameter file

Holding register 16 bit integer register R/W

Modbus	Name	Min/Max	Remarks	Default
4x0046	Not used			
4x0047	Not used			
4x0048	P term Heat	1/10000	Scale 1:100	5000
4x0049	I term Heat	1/10000	Scale 1:100	5
4x0050	P term Cool	1/10000	Scale 1:100	5000
4x0051	I term Cool	1/10000	Scale 1:100	5
4x0052	P term Change over	1/10000	Scale 1:100	5000
4x0053	I term Change over	1/10000	Scale 1:100	5
4x0054	SA 0% value	0/5000		0
4x0055	SA 100% value	5000/10000		10000
4x0056	EA 0% value	0/5000		0
4x0057	EA 100% value	5000/10000		10000
4x0058	Not used			
4x0059	Not used			
4x0060	Not used			
4x0061	Not used			
4x0062	Not used			
4x0063	Manual Temp	0-50	(degC) Only used in Manual state	
4x0064	Relative flow in manual mode	1/3	1=Eco flow, 2=Normal flow, 3=Boost flow. Only used in Manual state	
4x0065	Not used			
4x0066	CO2 min level	350/1000	(ppm)	500
4x0067	CO2 max level	350/2000	(ppm)	1000
4x0068	CO2/Volt	10/500	(ppm/volt)	200
4x0069	Copy of Coil Status 1-16	0/65535	" Bit0=0x0001 Bit1=0x0002 Bit2=0x0003 Bit3=0x0004 Bit4=0x0005 ... Bit15=0x0016"	

Conductor W4 BMS, applies to software from 0.76

Default values from parameter file

Modbus	Name	Min/Max	Remarks	Default
3x0001	Component Name ID	0/10	ID for type of controller in Conductor and Wise system	00003
3x0002 - 0017	Component Name	0/999	Name built of max 16 chr, exch chr (ASCII standard)	0
3x0018	Applacation ID			
3x0019	HW Serial No.			
3x0020	SW version			
3x0021	Not used			
3x0022	Application state	0/8	0=Init, 1=Auto Normal, 2=Auto Economy, 3=Manual, 4=Standby, 5=Emergency, 6=NightCool, 7=TimerFunction, 9=Holiday	1
3x0023	Not used			
3x0024	Not used			
3x0025	Time since last boot (Year)			
3x0026	Time since last boot (Hours)	0/8760	After 8760h Year is updated	
3x0027	Time since last boot (Minutes)	0/60	After 60min Hour is updated	
3x0028	Temp sensor regulator		Cels. Scaling 1:10 (external tempsensor connected to 19-20)	
3x0029	Temp sensor RU1		Cels. Scaling 1:10	
3x0030	Temp sensor RU2		Cels. Scaling 1:10	
3x0031	Temp set point RU		Setpoint in regulator form parameter or Room Unit	
3x0032	Flow set point RU		Econ-Normal-Boost	
3x0033	Battery level RU		Volts. Scaling 1:10	
3x0034	SA2 flow pressure MB sensor		(Pa)	
3x0035	SA flow pressure MB sensor		(Pa)	
3x0036	EA flow pressure MB sensor		(Pa)	
3x0037	Input Analog 1	0/10000	(mV)	
3x0038	Input Analog 2	0/10000	(mV)	
3x0039	Input Analog 3	0/10000	(mV)	
3x0040	Input Analog 4	0/10000	(mV)	
3x0041	Output PWM 1	0/100	(%)	
3x0042	Output PWM 2	0/100	(%)	
3x0043	Output PWM 3	0/100	(%)	
3x0044	Output PWM 4	0/100	(%)	
3x0045	Output Analog 1	0/10000	(mV)	
3x0046	Output Analog 2	0/10000	(mV)	
3x0047	Output Analog 3	0/10000	(mV)	
3x0048	Output Analog 4	0/10000	(mV)	
3x0049	PID Water Out	-100/100	(%)	
3x0050	PID ChangeOver Out	-100/100	(%)	

Conductor W4 BMS, applies to software from 0.76

Default values from parameter file

Input register 16 bit integer register Read only

Modbus	Name	Min/Max	Remarks	Default
3x0051	PID SA Out	-100/100	(%)	
3x0052	PID EA Out	-100/100	(%)	
3x0053	Cool Water	0/100	(%)	
3x0054	Warm Water	0/100	(%)	
3x0055	SA Damper pos.	0/100	(%)	
3x0056	EA Damper pos	0/100	(%)	
3x0057	Airflow SA2		(l/s)	
3x0058	Airflow SA1		(l/s)	
3x0059	Airflow EA		(l/s)	
3x0060	Room temp to controller		(degC) (if 2 RU, the average temperature of these)	
3x0061	Change over temp		(degC)	
3x0062	CO2 in room		ppm	
3x0063	Copy of Input Status 1-16	0/65535	"Bit0=0x0001 Bit1=0x0002 Bit2=0x0003 Bit3=0x0004 Bit4=0x0005 ... Bit15=0x0016"	
3x0064	Copy of Input Status 17-32	0/65535	"Bit0=0x0017 Bit1=0x0018 ... Bit15=0x0032"	
3x0065	Copy of Input Status 33-48	0/65535	"Bit0=0x0033 Bit1=0x0034 ... Bit15=0x0048"	
3x0066	Copy of Input Status 49-64	0/65535	"Bit0=0x0049 Bit1=0x0050 ... Bit15=0x0064"	

