

# PARASOL b



Integrated Comfort Modules

www.eurovent-certification.com  
www.certiflash.com



PARASOL

- ▶ 4-way air distribution, where each side has readjustable airflow rate and adjustable direction of air discharge for maximum comfort.
- ▶ High capacity – occupies little ceiling surface
- ▶ Easily readjustable nozzles in combination with Swegon's ADC (Anti Draught Control) offer maximum flexibility both today and for future needs.
- ▶ Available with installed control equipment and wireless communication.
- ▶ Hinged faceplate for simple access to the coil.
- ▶ Supply air
- ▶ Supply air, cooling
- ▶ Supply air, cooling and heating (electric or water-borne)
- ▶ PlusFlow variant with extra high rates of airflow for e.g. conference rooms.

Primary airflow:	Up to 85 l/s
Pressure range:	50 to 150 Pa
Total cooling capacity:	Up to 2055 W
Heating capacity: Water:	Up to 2700 W
Electric:	Up to 1000 W
Sizes:	PARASOL 600: PARASOL 1200:
	584 x 584 mm 1184 x 584 mm
	592 x 592 mm 1192 x 592 mm
	598 x 598 mm 1198 x 598 mm
	617 x 617 mm 1242 x 617 mm
	623 x 623 mm 1248 x 623 mm
	642 x 642 mm 1292 x 642 mm
	667 x 667 mm 1342 x 667 mm
	Height: 220 mm Height: 220/240* mm
	*=Parasol 1200 PF





### Parasol Comfort Modules

Parasol is the generic name of a family of products consisting of comfort modules. The modules are designed to supplement one another and together create optimal room comfort.

Modules: Supply air  
 Supply air and cooling  
 Supply air, cooling and heating (water)  
 Supply air, cooling and heating (electric)

Installation: Flushed mounting for false ceiling constructions

### Function

The comfort modules operate on a basic principle that is closely akin to that of chilled beams. The difference is mainly that the comfort module distributes air in four directions instead of two. This maximizes the area where supply air is mixed with room air so that the modules discharge air at high capacity, yet they do not occupy more ceiling space than necessary.

The comfort modules are also optimized to quickly mix the discharged air with room air providing better comfort in the room. In heating applications, this technique can be advantageously utilized to efficiently provide provide heat along the ceiling.

### Flexibility

The easily adjustable nozzles in combination with Swegon ADC<sup>II</sup> (Anti-Draught Control), offer maximal flexibility if changes in the room layout become necessary.

All the sides can be set independently of one another so that the comfort module can distribute more or less air and simultaneously discharge air in whatever direction desired in the room.

### Design

The face plate of the Parasol has three different perforation patterns. As standard, the face plate has round perforations arranged in a triangular pattern however other variants are available as special order.

### Draught-free indoor climate

The Parasol has a four-way air distribution, providing low air velocities into the space. The low air velocity is reached by distributing the cooled air over a large surface area. The special design of the outlet creates a turbulent flow, which causes the air to be quickly mixed with the room air. The comfort module's closed design with a recirculation grille for return air in the face of the unit also contributes to the advantageous mixing performance.

### Variants

The Parasol is available in the following coil/heat exchanger variants:

Variant A: Supply air and water-borne cooling from a coil

Variant B: Supply air, water-borne cooling and heating from a coil.

Variant C: Supply air

Variant X: Supply air, water-borne cooling from a coil and heating from electric heating elements inside the coil.

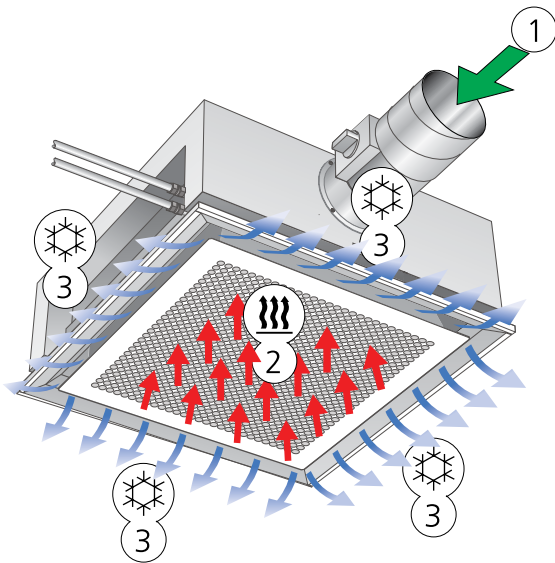

Figure 1. Variant A: Cooling and supply air operation  
 1 = Primary air  
 2 = Induced room air  
 3 = Primary air mixed with chilled room air

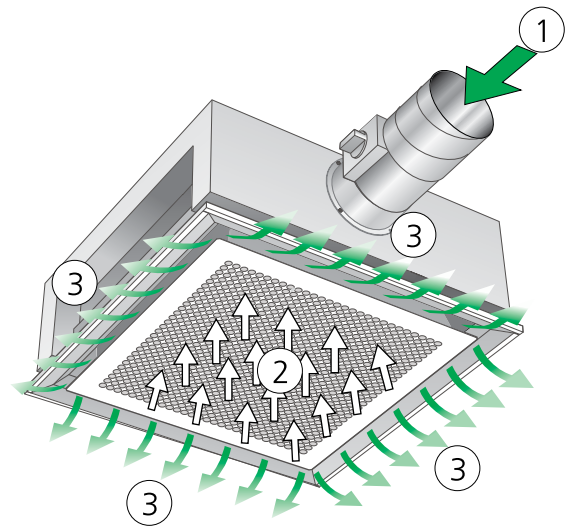

Figure 3. Variant C: Supply air operation  
 1 = Primary air  
 2 = Induced room air  
 3 = Primary air mixed with room air

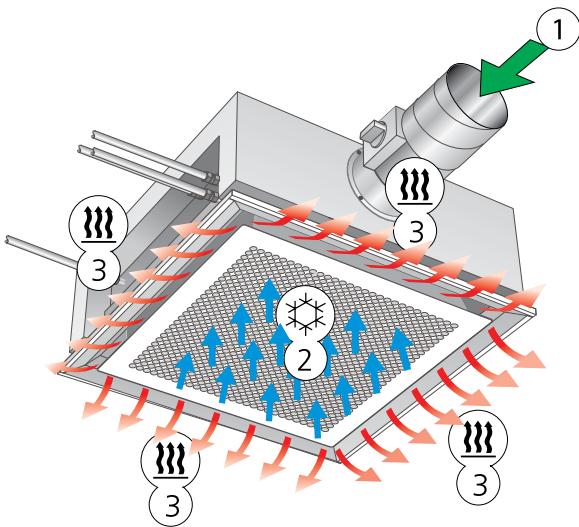

Figure 2. Variant B: Heating and supply air operation (includes also cooling operation)  
 1 = Primary air  
 2 = Induced room air  
 3 = Primary air mixed with heated room air

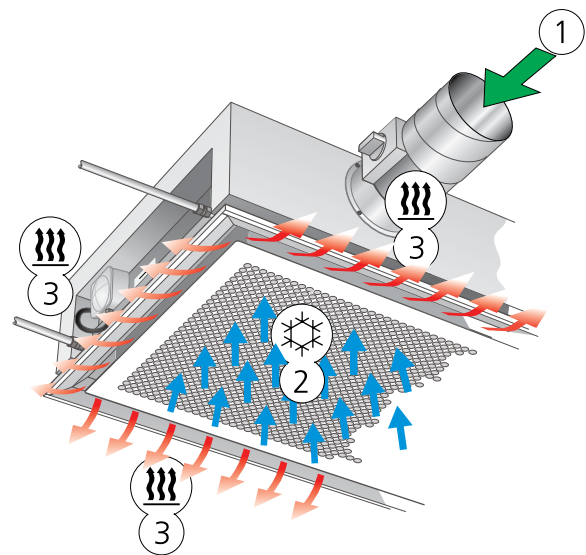

Figure 4. Variant X: Supply air and heating operation with electric heating elements (includes also cooling operation)  
 1 = Primary air  
 2 = Induced room air  
 3 = Primary air mixed with heated room air

PARASOL

### Supply air module

A comfort module for supply air only is available (variant C – without a coil) to supplement certain types of rooms where the occupants need a large quantity of air, but only a smaller amount of water-based cooling energy. This applies, for instance, to certain conference rooms or the inner zones in large rooms. To avoid over-sizing, it is common to combine units with cooling function and units with supply air function only. Since the supply air variant is also designed according to the induction principle, it is possible to discharge supply air substantially below room temperature and yet not need to think about possible reheating, which may be required in combined systems with chilled beams and air diffusers. The rate of induction varies depending on pressure and flow conditions but lies generally in the range of 3-5 which means that if you add 30 l/s, 3 to 5 times as much warm room air (90–150 l/s) will be induced. The mixed air then has a substantially higher temperature than the temperature of the supply air which reduces the risk of draught in the occupied zone.

Another advantage of the supply air module is, that it operates with the same duct pressure as the modules with coil. In other words, there is no need to throttle the pressure in any duct branch more than necessary. Instead of incorporating a coil into the supply air module, the module has an induction control with punched nozzles that is designed to provide the same rate of induction as the units with a coil. This makes it possible to use Swegon ProSelect, the dimensioning program for sizing the throw lengths, even for supply air modules. If shorter throw lengths than standard are desirable, certain openings can be plugged to reduce the free area in the induction control, to reduce the percentage of induced room air. The capacity of the primary air is never affected by an increase or decrease in the rate of induction.

### PARASOL PlusFlow

If you need both high cooling capacity and high airflows, then the Parasol 1200 PF is the right choice. Parasol PF installed in a conference room, for instance, can reduce the number of installed products by 50%.

The module can handle large airflows and at the same time has the same high cooling and heating capacity as an ordinary Parasol, of course with maintained high level of comfort in the room.

The PlusFlow unit operates like a standard Parasol, but it differs in that it distributes air to the room via two separate rows of nozzles. One row of nozzles lacks flow adjustment capability and is always open. The other row of nozzles is adjustable by means of nozzle strips just like the other Parasol modules.

This means that when all the adjustable nozzle strips close, the product still provides an airflow.

Sizing can be carried out in the same way as for the supply air module and our ordinary Parasol using our ProSelect sizing program.

### High capacity

Thanks to its high capacity, the Parasol utilizes 40-50% less ceiling surface to take care of the cooling load in a normal office, compared with a traditional chilled beam.

### Simple to adjust

By means of its integrated nozzle adjustment with a multitude of possible settings, the Parasol provides optimal comfort and can easily be adapted in the event of refurbishment of room sizes or if the nature of the business changes. The comfort module can be set so that different volumes of air are distributed on each side and for both high and low rates of airflow.

### Range of application

The Parasol is ideal for use as a standard application in such premises as:

- Offices and conference rooms
- Classrooms
- Hotels
- Restaurants
- Hospitals
- Shops
- Shopping centres

With its many installation options, The Parasol functions can easily be adapted to a new kind of business or to changes in the layout of the room.

### Simple to install

The dimensions of the small, compact Parasol units fit those of the most commonly used ceiling modules, which also makes them easy to install. The small dimensions are useful during handling, especially when the products are handled at the building site, with less damage caused by handling and reduced health and safety issues.

### Ceiling system flexibility

The range available includes module dimensions to fit the standardized ceiling dimensions: c-c 600, 625 and 675 mm. There is also an installation frame for plaster ceilings and ceiling solutions of the 'clip-in' type, e.g. Dampa and FineLine.

### Always in stock

To ensure short delivery times, the Parasol standard versions, with the most common functions, are held in stock.

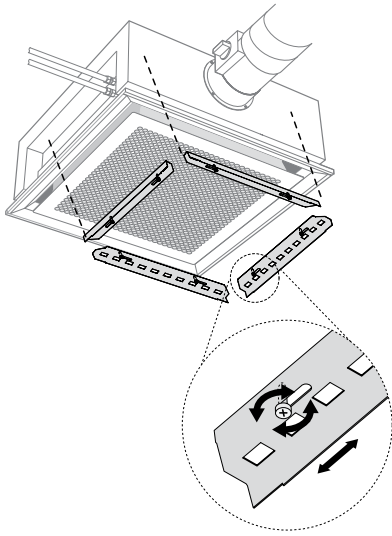

Figure 5. Nozzle adjustment

**ADC<sup>II</sup>**

All the comfort modules contain ADC<sup>II</sup> as standard. ADC stands for Anti Draught Control, which enables you to set the diffusion pattern of the air being distributed to avoid risk of draught. A number of ADC<sup>II</sup> sections with four air deflectors per section are arranged on each side of the unit. Each section is adjustable from a straight setting to 40° air deflection to the right or left in increments of 10°. This provides enormous flexibility and can be easily adjusted without at all having to affect the system as a whole.

The sound level and static pressure is not affected at all by the ADC<sup>II</sup>. The water capacity is reduced by 5-10% when the ADC<sup>II</sup> is adjusted to fan-shape setting.

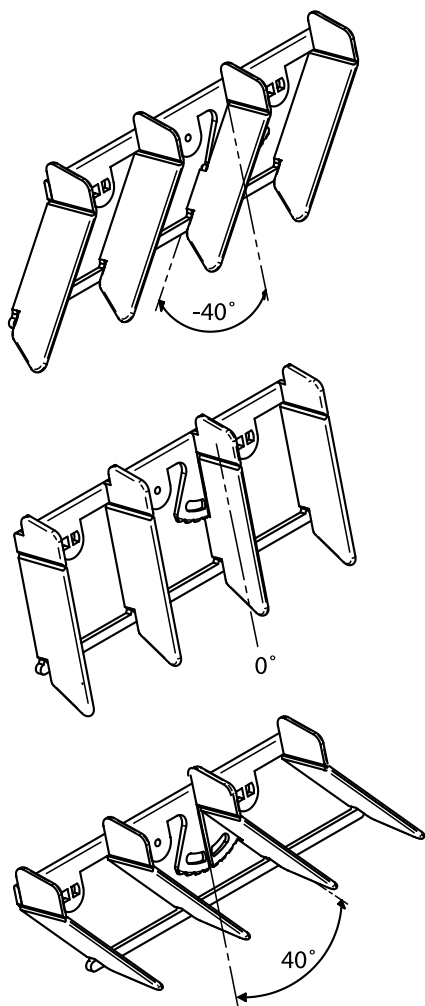

Figure 6. ADC<sup>II</sup>, setting range from -40° to +40° in increments of 10°

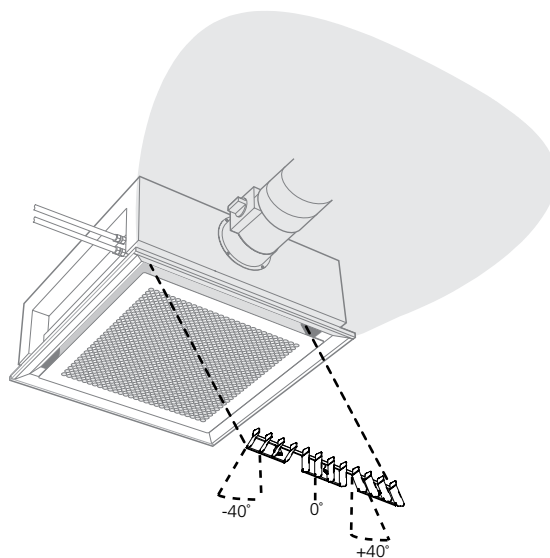

Figure 7. Possible settings for the ADC<sup>II</sup>, Fan shape

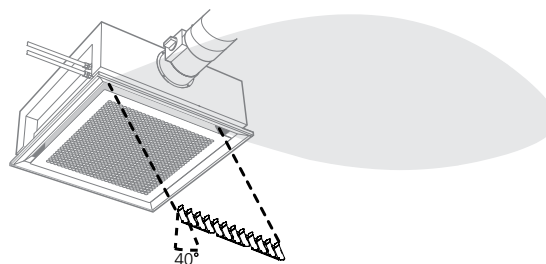

Figure 8. Possible settings for the ADC<sup>II</sup>, X-shape

**Aesthetic flexibility**

The face of the unit is available with three different perforation patterns, so that it can be adapted to suit different kinds of ceiling components, e.g. light fittings and exhaust grilles that share the surface in a suspended ceiling. This avoids the clutter effect of mismatched components.

Other patterns are, of course, available on special order. For further details, get in touch with your nearest Swegon representative.

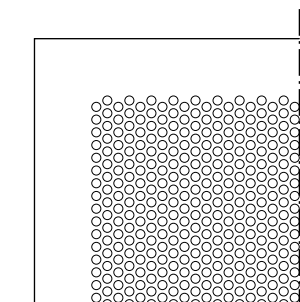

Figure 9. Standard face plate

Circular holes arranged in a triangular pattern.

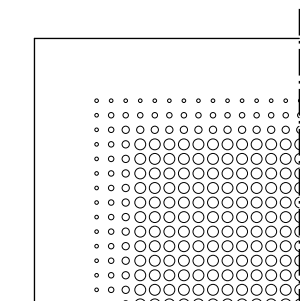

Figure 10. PD face plate

Circular holes arranged in a square pattern with a graduated border

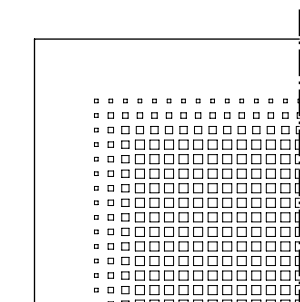

Figure 11. PE face plate

Square holes arranged in a square pattern with a graduated border

### Optional factory-fitted room climate control system.

To make the installation work even simpler, it is possible to order LUNA and CONDUCTOR room climate control equipment factory-fitted to the PARASOL.

#### CONDUCTOR

When CONDUCTOR control equipment is factory-fitted to the system, the actuator (cooling and heating) and the condensation sensor are prewired to the controller on delivery. The controller must be energized before it can be started up. This is done either by supplying 24 V AC from a network or through the addition of a separate transformer.

The room unit is delivered well packaged together with the PARASOL. The room controller can either operate with wireless remote control or via a wired cable connection. If the controller operates through wireless communication, it is powered by 4 size AAA batteries. If a cable connection is used, the room unit is supplied with power via the same cabling used for communication between the module controller and the room controller. As soon as you switch on the current to the module controller and the room controller, simply enter the ID number of the module controller into the room controller to start wireless communication. If the room controller is connected via a cable, you are not required to enter any ID number.

There are several accessories available to special order for utilising the energy saving functions available in the CONDUCTOR with the W4 application. For more information about the CONDUCTOR, see the separate product datasheet.

#### LUNA

If the PARASOL is equipped with factory-fitted LUNA climate control equipment, the actuator (cooling and heating) as well as the condensation sensor are prewired to a terminal block.

There is no controller inside the PARASOL, since the intelligence in the LUNA is integrated into the room unit. The controller must be ordered separately and is supplied in separate robust packaging together with the PARASOL. The controller must be energized in order to start the control function. This is done either by supplying 24 V AC from a network or through the addition of a separate transformer.

#### PARASOL with electric heating

The LUNA can also be used as a controller for the Parasol variant with electric heating. In this solution, you have to relocate a jumper inside the controller and reprogram its heating output signal for the control of a Triac unit with pulse-width modulation. The Triac unit in turn supplies current to the heating elements in the Parasol with regulated 230 V power (see Figure 15).

You will find other information about the LUNA indoor climate control equipment in a separate product datasheet at [www.swegon.com](http://www.swegon.com).

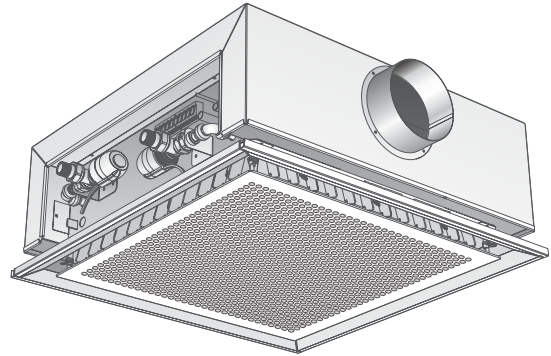

Figure 12. LUNA - Factory-fitted climate control. (PARASOL b T-RK-LUNA)

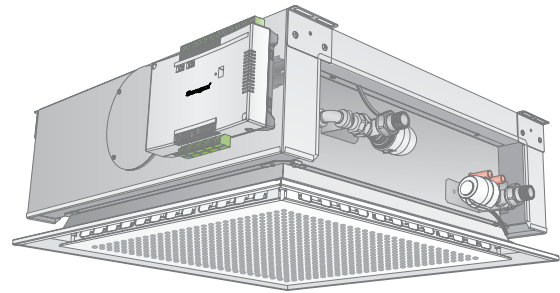

Figure 13. CONDUCTOR - Factory-fitted climate control (PARASOL b T-COND-XX)



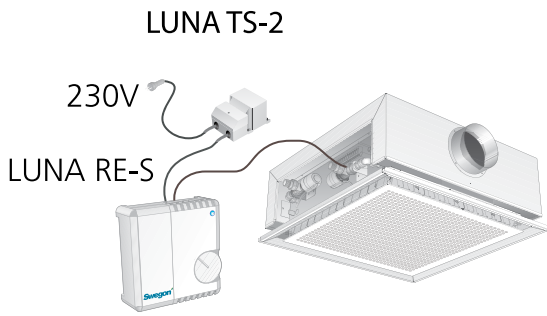

Figure 14. Typical installation, water-based cooling and heating

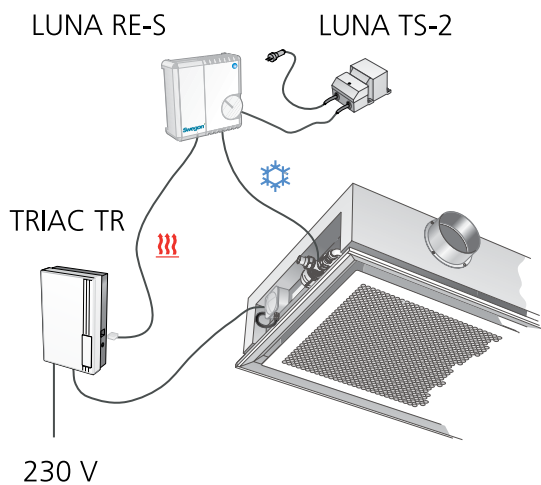

Figure 15. Installation, water-based cooling and electric heating

**To adjust the valve SYST VEN 115**

On delivery, the valves are fully open (position N:  $k_v$  0.89). Set the desired  $k_v$  value when commissioning. The flow rate can be set by adjusting the valve cone setting. This is easily done using the protective housing (supplied with the unit) with a  $k_v$  scale having marks of different length (see Table 1). The lifting height is always the same regardless of setting.

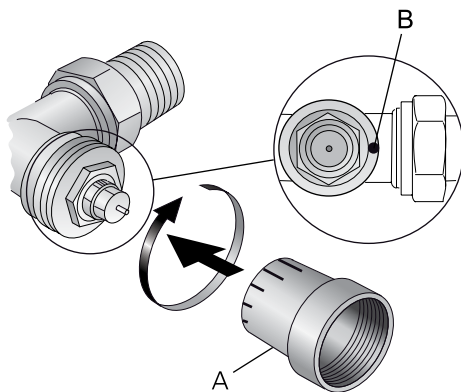
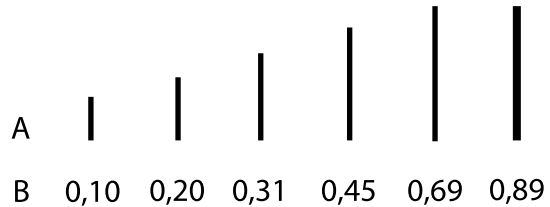

Figure 16. To adjust the  $k_v$  value.  
A = Protective housing, rotatable through 180°  
B = Marking on the outlet side of the valve

1. Fit the protective housing A over the valve.
2. Turn the protective housing until the desired reference mark is centred with mark B on the valve.

**Table 1.  $k_v$  value (m<sup>3</sup>/h) for different adjustment marks**



A = Reference mark

B =  $k_v$  value

**Valve maintenance SYST VEN 115**

The valves do not normally require any maintenance at all. If anything should damage the stuffing box, it can be replaced even while the system is under pressure. A special tool is required for this..

**Technical Data, Valve**

PN class	PN 10
Permissible media:	Chilled and hot water with anti-freeze agent Recommendation: Water treatment according to VDI 2035
Media temperature:	1...120°C
Permissible operating pressure:	1000 kPa (10 bar)
Closing pressure:	60 kPa (0.6 bar)
Pressure drop for fully open valve ( $\Delta p_v$ 100):	recommended range: 5 ... 20 kPa (0.05 ... 0.2 bar)
Lifting height:	2 mm

**Material**

Valve body:	Brass, dull nickel plated
Connection nipple:	Brass, dull nickel plated
Protective housing:	Polypropylene
O-ring:	EPDM

**Connection**

R male threads: ½" B to ISO 7/1

**Inlet/Outlet**

Rp female threads: ½" to ISO 7/1

## Installation

### Recommended types of ceiling

Parasol is designed for use in most T-grid ceiling systems and clip-in type ceilings in terms of length and width. To guarantee a quality finish in T-grid systems, we recommend a T profile with a width of 24 mm.

### Suspension

The double-module units have four mounting brackets for their suspension, and are installed using one threaded rod in each mounting bracket (Figure 17). A double threaded rod with a thread lock should be used if there is substantial distance between the overhead slab and the unit. If the unit is to be mounted directly against the ceiling, use a 200 mm long threaded rod

The threaded rod, assembly piece SYST MS M6 (Figure 20), must be ordered separately.

### Connection dimensions

Water - cooling, plain pipe end (Cu)	Ø 12 x 1.0 mm
Water - heating, plain pipe end (Cu)	Ø 12 x 1.0 mm
Air, connecting piece	Ø 125 mm
Air, connecting piece (Variant PF)	Ø 160 mm

### To connect the air

Parasol is supplied as standard with an open air connection on the right-hand side (seen from the side where the water is connected).

The air connection piece is supplied and must be installed so that it can then be connected to the primary air duct (see Figure 19). A cap is fitted at the factory to the left-hand air connection, but the connections can easily be switched if the air connection spigot has to be fitted to the left.

### To connect the water

Connect the water pipes using push-on couplings, clamping ring couplings or sleeve nut. Note that clamp ring couplings require support sleeves inside the pipes.

Do not use a solder coupling to connect the water pipes. High temperatures can damage the unit's existing solders. Flexible connection hoses for water may be ordered separately.

### Connecting the electric heating elements

Swegon's LUNA or your own control system can be used for controlling the heating elements in the electric variant of the Parasol. For particulars on how to wire the LUNA control system and necessary how to relocate the jumper, see our separate product datasheet and the installation instructions available at our website: [www.swegon.com](http://www.swegon.com).

If you use a control system of your own, wire the electrical connections to the screw terminal blocks in Parasol's terminal box according to the table below.

Conductor colour, terminal box	Conductor's function
Brown	Phase, 230 V AC
Blue	zero conductor
Green/yellow	protective earth
White	Overheating protection*
Black	Overheating protection*

\* Text inputs for overheating protection with manual reset.

### Overheating protection

The Parasol with electric heating is equipped with two thermal overheat protections.

The protection, with automatic reset, switches out the heating elements (the zero conductor) when the temperature exceeds 60 °C. When the temperature has dropped to 50 °C the protection closes the circuit again and reenergizes the heating elements. If the temperature rises to 75 °C the second overheat protection will trip, this protection requires a manual reset, switches out the heating elements (the phase conductor).

The perforated face plate must first be removed before you can reset the overheat protection. The red reset button is situated between the air heater and the end panel through which the cooling water pipes are installed. After the overheat protection has been reset, refit and press the face plate to secure it.

### CE marking

The Parasol with electric heating is CE marked in accordance with applicable regulations. The CE Declaration of Conformity is available at our website: [www.swegon.com](http://www.swegon.com).

### Condensation-free cooling

Since the comfort modules have to be dimensioned to operate without condensation, no drainage system is required.

### To connect the indoor environment control equipment

If the indoor environment control system is fitted in the factory, connect the return pipe for chilled water and heating directly to the valve (external thread DN ½"). Connect all connecting electrical cables to the connection card with spring-loaded terminals provided.

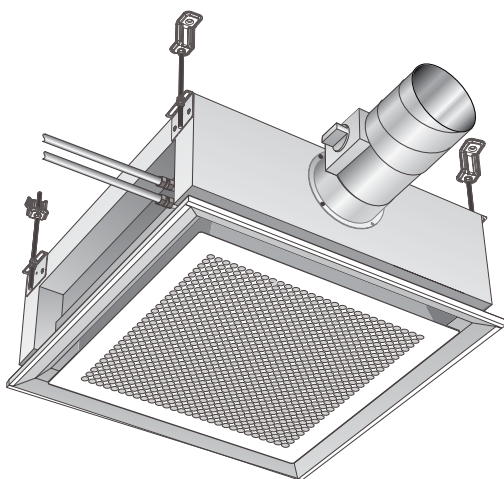

Figure 17. Suspending a single-module unit

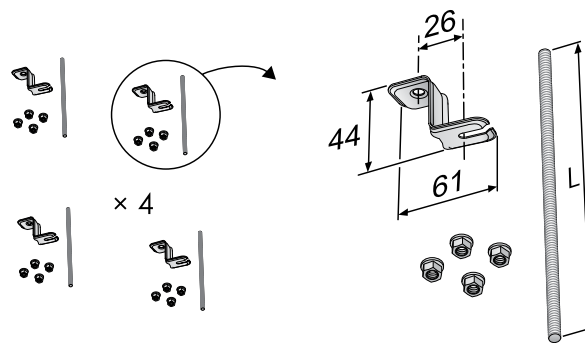

Figure 20. Assembly piece SYST MS M6-1, ceiling mount and threaded rod.

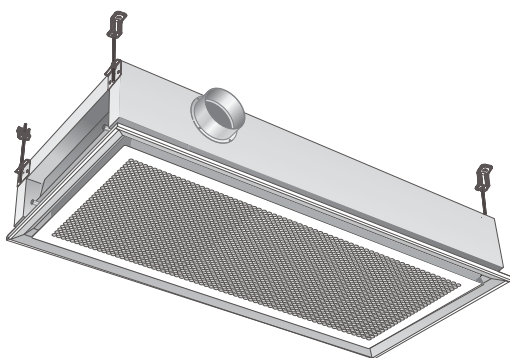

Figure 18. Suspending a double-module unit

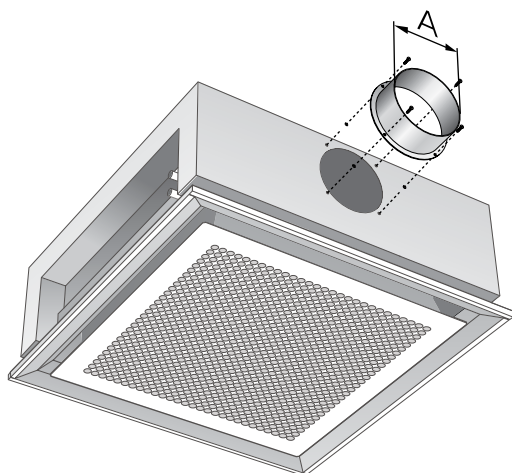

Figure 19. Air connection piece

Variant

Parasol 600 MF	A = Ø 125 mm
Parasol 1200 LF, MF, HF	A = Ø 125 mm
Parasol 1200 PF	A = Ø 160 mm

PARASOL

## Technical data

Cooling capacity, max.	2055 W
Heating capacity, water, max.	2700 W
Heating capacity, electric, max.	1000 W
Airflow	
Single-module unit	7-34 l/s
Double-module unit	7-85 l/s
Length	
Single-module unit	584; 592; 598; 617; 623; 642; 667 mm
Double-module unit	1184; 1192; 1198; 1242; 1248; 1292; 1342 mm
Width	584; 592; 598; 617; 623; 642; 667 mm
Height	
Parasol 600 MF	220 mm
Parasol 1200 LF, MF, HF	220 mm
Parasol 1200 PF	240 mm
Dimensions of the units have a tolerance of (±2) mm.	

## Weight table

PARASOL	Dry weight (kg)	Water volume Cooling (l)	Water volume Heating (l)
1192-A-LF/MF/HF	22,6	1,4	X
1192-B-LF/MF/HF	26,0	1,4	0,9
1192-C-LF/MF/HF	20,3	X	X
1192-A-PF	25,2	1,4	X
1192-B-PF	28,8	1,4	0,9
592-A-LF/MF/HF	14,3	0,6	X
592-B-LF/MF/HF	14,4	0,6	0,2
592-C-LF/MF/HF	11,6	X	X
1192-X1	27,4	1,4	X
1192-X2	27,7	1,4	X

*These are examples of the most common sizes of Parasol. For other variants, we refer to our ProSelect program at [www.swegon.com](http://www.swegon.com)*

## Recommended limit values

### Pressure levels

Coil working pressure, max.	1600 kPa *
Coil test pressure, max.	2400 kPa *

\* *Applicable without control equipment fitted*

### Nozzle pressure

Recommended min. nozzle pressure if coil heat is used, $p_i$	50-150 Pa
Recommended min. nozzle pressure with face plate in the high output mode	70 Pa

### Water flow

*Ensures evacuation of any air pockets in the system.*

Cooling water, min.	0.030 l/s
Heating water, min.	0.013 l/s

### Temperature differentials

Cooling water, temperature increase	2-5 K
Heating water, drop in temperature	4-10 K

*Temperature differences are always expressed in Kelvin (K).*

### Flow temperature

Cooling water	**
Heating water, max.	60°C

\*\* *Cooling water must always be kept at a level that ensures that no condensation is formed.*

## Designations

P	Capacity (W)
$t_i$	Temperature of primary air (°C)
$t_r$	Temperature of room air (°C)
$t_m$	Mean water temperature (°C)
$\Delta T_m$	Temperature difference $t_r - t_m$ (K)
$\Delta T_l$	Temperature difference $t_i - t_r$ (K)
$\Delta T_k$	Temperature difference of cooling water flow and return (K)
$\Delta T_v$	Temperature difference of heating water flow and return (K)
v	Water velocity (m/s)
q	Airflow (l/s)
P	Pressure (Pa)
$\Delta p$	Pressure drop (Pa)

*Supplementary index: k = cooling, v = heating, l = air, i = initial adjustment, corr = correction*

### Pressure drop in nozzle

$$\Delta p_i = (q_i / k_{pi})^2$$

$\Delta p_i$	Pressure drop in nozzle (pa)
$q_i$	Flow of primary air (l/s)
$k_{pi}$	Pressure drop constant for nozzle setting, <b>see Tables 2-6</b>

## Cooling

### Standard

The cooling capacities have been measured in accordance with EN 15 116 and have been converted for constant water flow according to Diagram 2/3.

### Calculating Formulae - Cooling

Below are some formulae that enable the user to calculate which comfort module selection is applicable. The values for the calculations can be taken from the tables.

#### Pressure drop in cooling circuit

$$\Delta p_k = (q_k / k_{pk})^2$$

$\Delta p_k$  Pressure drop in cooling coil (kPa)

$q_k$  Flow of cooling water (l/s), see **Chart 1**

$k_{pk}$  Pressure drop constant for cooling circuit, see Tables 2-6

#### Cooling capacity of the air

$$P_1 = 1,2 \cdot q_1 \cdot \Delta T_1$$

$P_1$  Cooling capacity of the primary air (W)

$q_1$  Flow of primary air (l/s)

$\Delta T_1$  Temperature difference between primary air ( $t_1$ ) and room air ( $t_r$ ) (K)

#### Water's cooling capacity

$$P_k = 4186 \cdot q_k \cdot \Delta T_k$$

$P_k$  Cooling capacity of the water (W)

$q_k$  Cooling water flow (l/s)

$\Delta T_k$  Temperature difference of cooling water flow and return (K)

### Chart 1. Water Flow – Cooling Capacity

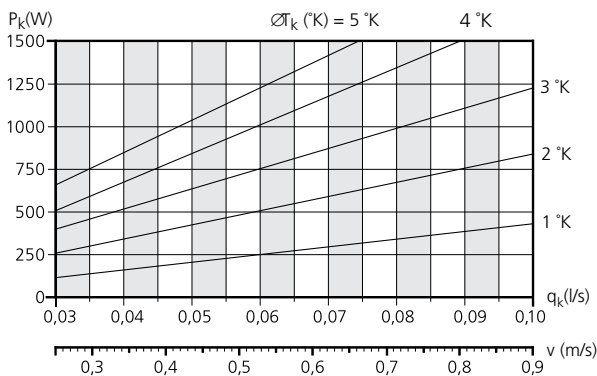

### Corrected capacity – water flow

Different water flow rates to some extent have effects on the capacity output. By checking calculated water flow against Chart 2 or 3, the capacity indicated in **Tables 2-6** may need to be slightly adjusted up or down.

$$P_{corr} = k \cdot P_k$$

$P_{corr}$  Corrected capacity (W)

$k$  Correction factor

$P_k$  Cooling capacity of the water

### Chart 2. Corrected Capacity – Water flow, Parasol 600

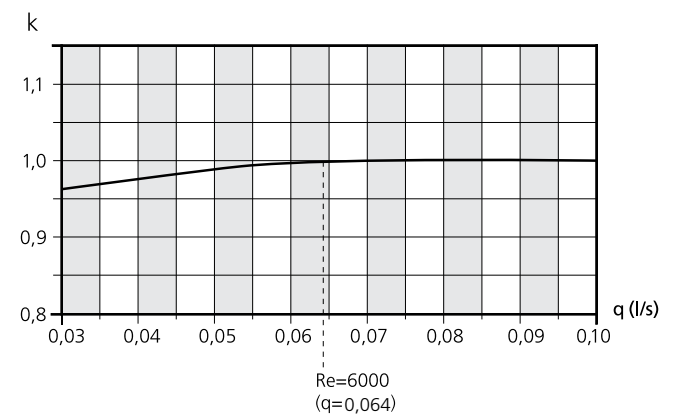

### Chart 3. Corrected Capacity – Water flow, Parasol 1200

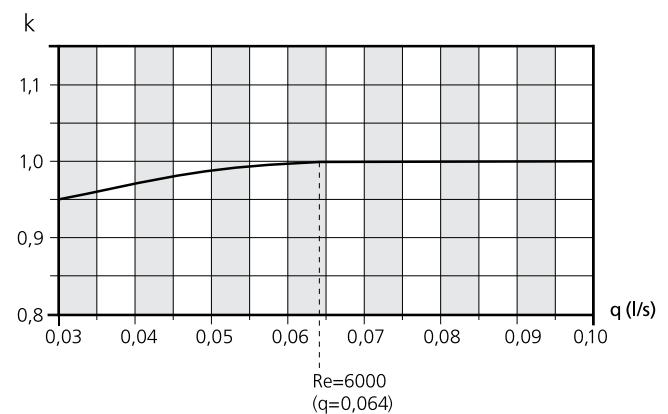
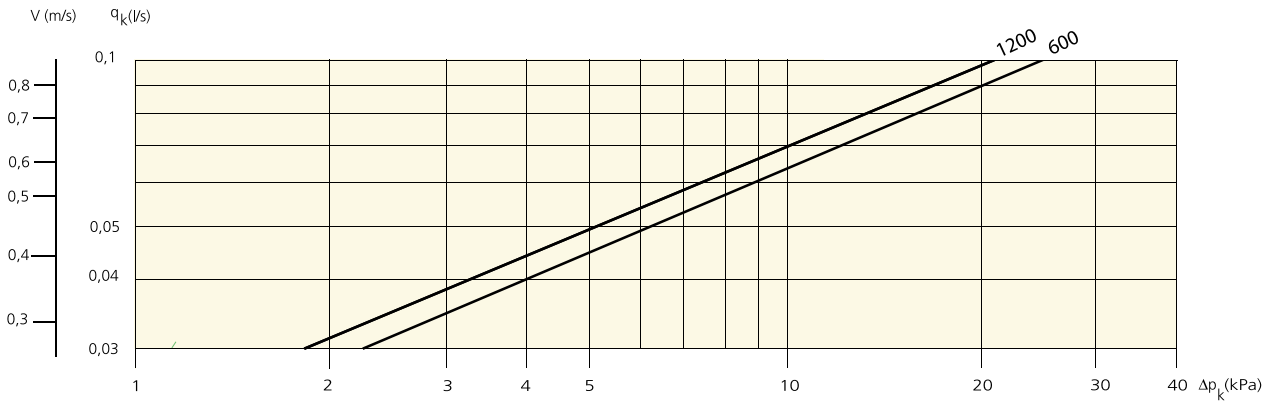

Chart 4. Pressure Drop – Cooling Water Flow



**Table 2 – Data – Cooling Sizing Guide for Parasol 600 MF units**

Unit length (mm)	Nozzle setting 1)	Primary airflow (l/s)	Sound level in dB(A) 2)	Nozzle pressure $p_i$ (Pa)	Cooling capacity Primary air (W) at $\Delta T_i$				Cooling capacity water (W) at $\Delta T_{mk}$ 3)								Pressure drop constant air/water	
					6	8	10	12	6	7	8	9	10	11	12	$k_{pl}$	$k_{pk}$	
600	LLLL	7	<20	48	50	67	84	101	190	220	250	280	309	339	368	1,01	0,0200	
600	LLLL	8	<20	62	58	77	96	115	217	251	286	321	355	389	423	1,01	0,0200	
600	LLLL	9	<20	79	65	86	108	130	241	279	318	357	395	434	472	1,01	0,0200	
600	LLLL	10	22	98	72	96	120	144	262	304	347	389	431	473	515	1,01	0,0200	
600	LLLL	12	27	140	86	115	144	173	299	348	397	445	494	542	591	1,01	0,0200	
600	MMMM	12	<20	47	86	115	144	173	227	262	297	331	365	398	432	1,76	0,0200	
600	MMMM	14	22	63	101	134	168	202	263	305	345	386	426	467	507	1,76	0,0200	
600	MMMM	16	26	83	115	154	192	230	294	341	388	434	480	526	571	1,76	0,0200	
600	MMMM	18	30	105	130	173	216	259	322	374	425	476	527	578	629	1,76	0,0200	
600	MMMM	20	33	129	144	192	240	288	346	402	458	514	569	625	680	1,76	0,0200	
600	HHHH	20	20	52	144	192	240	288	285	331	377	422	468	514	559	2,77	0,0200	
600	HHHH	23	25	69	166	221	276	331	324	376	428	479	530	581	632	2,77	0,0200	
600	HHHH	26	28	88	187	250	312	374	359	416	473	529	585	641	697	2,77	0,0200	
600	HHHH	30	33	117	216	288	360	432	399	462	525	587	649	711	772	2,77	0,0200	
600	HHHH	34	36	150	245	326	408	490	434	503	571	638	705	771	838	2,77	0,0200	

**Table 3 – Data – Cooling Sizing Guide for Parasol 1200 LF units**

Unit length (mm)	Nozzle setting 1)	Primary airflow (l/s)	Sound level in dB(A) 2)	Nozzle pressure $p_i$ (Pa)	Cooling capacity Primary air (W) at $\Delta T_i$				Cooling capacity water (W) at $\Delta T_{mk}$ 3)								Pressure drop constant air/water	
					6	8	10	12	6	7	8	9	10	11	12	$k_{pl}$	$k_{pk}$	
1200	LLLL	7	<20	60	50	67	84	101	293	340	388	435	482	529	575	0,90	0,022	
1200	LLLL	8	<20	78	58	77	96	115	330	384	437	491	544	597	650	0,90	0,022	
1200	LLLL	9	<20	99	65	86	108	130	363	422	481	540	599	657	716	0,90	0,022	
1200	LLLL	10	<20	122	72	96	120	144	393	457	520	584	648	711	775	0,90	0,022	
1200	LLLL	11	23	148	79	106	132	158	419	488	556	624	692	760	828	0,90	0,022	
1200	MMMM	9	<20	49	65	86	108	130	299	349	398	448	497	547	597	1,28	0,022	
1200	MMMM	10	<20	61	72	96	120	144	329	384	439	494	549	604	659	1,28	0,022	
1200	MMMM	12	<20	88	86	115	144	173	382	446	510	574	638	702	766	1,28	0,022	
1200	MMMM	14	<20	120	101	134	168	202	427	498	570	642	713	785	857	1,28	0,022	
1200	MMMM	16	23	156	115	154	192	230	465	544	622	700	779	857	936	1,28	0,022	
1200	HHHH	16	<20	54	115	154	192	230	400	466	533	599	666	732	798	2,18	0,022	
1200	HHHH	18	<20	68	130	173	216	259	438	511	584	657	730	803	876	2,18	0,022	
1200	HHHH	21	<20	93	151	202	252	302	487	569	650	732	814	895	977	2,18	0,022	
1200	HHHH	24	23	121	173	230	288	346	530	619	708	797	886	976	1065	2,18	0,022	
1200	HHHH	27	26	153	194	259	324	389	568	664	759	855	951	1046	1142	2,18	0,022	

1) The grey-shaded area indicates the delivery settings for modules ordered from stock. For the sizing of alternative nozzle settings, use Swegon ProSelect, the sizing program that is available at [www.swegon.com](http://www.swegon.com).

2) The specified noise level is applicable to connection without damper or with fully open damper. In other applications that call for throttling by means of a SYST CRPc 9–125 commissioning damper fitted directly to the unit, the required data can be read using the Swegon ProSelect sizing program. Room attenuation = 4 dB

3) The specified capacities are based on operation with the face plate in the high capacity position. Operation with the face plate set to the normal position reduces the water capacity of the Parasol 600 by about 5% and that of the Parasol 1200 by about 10 %.

The water capacity can vary depending on the installation and how the air deflectors are set. The primary air capacity is not affected. N.B.! The total cooling capacity is the sum of the air-based and water-based cooling capacities.

PARASOL

**Table 4 – Data – Cooling. Sizing Guide for Parasol 1200 MF units**

Unit length (mm)	Nozzle setting 1)	Primary airflow (l/s)	Sound level in dB(A) 2)	Nozzle pressure $p_i$ (Pa)	Cooling capacity Primary air (W) at $\Delta T_i$				Cooling capacity water (W) at $\Delta T_{mk}$ 3)						Pressure drop constant air/water		
					6	8	10	12	6	7	8	9	10	11	12	$k_{pl}$	$k_{pk}$
1200	LLLL	9	<20	49	65	86	108	130	313	365	417	469	521	573	625	1,28	0,022
1200	LLLL	10	<20	61	72	96	120	144	345	403	460	518	575	633	690	1,28	0,022
1200	LLLL	12	<20	88	86	115	144	173	400	467	534	601	668	736	803	1,28	0,022
1200	LLLL	14	<20	120	101	134	168	202	447	522	597	672	747	823	898	1,28	0,022
1200	LLLL	16	22	156	115	154	192	230	488	570	652	734	816	898	980	1,28	0,022
1200	MMMM	13	<20	50	94	125	156	187	349	407	466	524	582	641	700	1,84	0,022
1200	MMMM	15	<20	67	108	144	180	216	397	463	528	593	658	724	789	1,84	0,022
1200	MMMM	17	<20	85	122	163	204	245	439	511	582	654	725	796	867	1,84	0,022
1200	MMMM	20	23	118	144	192	240	288	494	574	653	732	811	890	968	1,84	0,022
1200	MMMM	22	26	143	158	211	264	317	526	611	695	778	862	944	1027	1,84	0,022
1200	HHHH	22	<20	50	158	211	264	317	416	486	555	625	695	764	834	3,12	0,022
1200	HHHH	25	<20	64	180	240	300	360	463	540	617	694	771	847	924	3,12	0,022
1200	HHHH	28	22	81	202	269	336	403	505	588	671	755	838	921	1004	3,12	0,022
1200	HHHH	33	26	112	238	317	396	475	565	658	750	843	935	1028	1120	3,12	0,022
1200	HHHH	38	30	148	274	365	456	547	616	717	818	919	1019	1120	1220	3,12	0,022

**Table 5 – Data – Cooling. Sizing Guide for Parasol 1200 HF units**

Unit length (mm)	Nozzle setting 1)	Primary airflow (l/s)	Sound level in dB(A) 2)	Nozzle pressure $p_i$ (Pa)	Cooling capacity Primary air (W) at $\Delta T_i$				Cooling capacity water (W) at $\Delta T_{mk}$ 3)						Pressure drop constant air/water		
					6	8	10	12	6	7	8	9	10	11	12	$k_{pl}$	$k_{pk}$
1200	LLLL	13	<20	50	94	125	156	187	384	445	507	568	629	690	750	1,84	0,022
1200	LLLL	15	<20	67	108	144	180	216	425	494	562	629	697	764	831	1,84	0,022
1200	LLLL	17	<20	85	122	163	204	245	462	536	610	683	757	830	903	1,84	0,022
1200	LLLL	20	23	118	144	192	240	288	509	591	672	753	834	915	995	1,84	0,022
1200	LLLL	22	26	143	158	211	264	317	536	623	709	794	880	965	1049	1,84	0,022
1200	MMMM	23	<20	52	166	221	276	331	451	523	595	666	737	808	878	3,20	0,022
1200	MMMM	26	23	66	187	250	312	374	490	568	645	722	799	875	951	3,20	0,022
1200	MMMM	30	27	88	216	288	360	432	534	619	704	787	871	954	1037	3,20	0,022
1200	MMMM	34	31	113	245	326	408	490	573	664	755	845	934	1023	1112	3,20	0,022
1200	MMMM	39	35	149	281	374	468	562	616	714	811	907	1003	1099	1194	3,20	0,022
1200	HHHH	36	26	51	259	346	432	518	521	601	680	759	837	914	990	5,04	0,022
1200	HHHH	40	28	63	288	384	480	576	559	645	729	812	895	977	1058	5,04	0,022
1200	HHHH	45	31	80	324	432	540	648	602	693	783	872	960	1047	1134	5,04	0,022
1200	HHHH	50	34	98	360	480	600	720	640	736	831	925	1018	1110	1201	5,04	0,022
1200	HHHH	55	36	119	396	528	660	792	674	775	875	973	1071	1167	1262	5,04	0,022

1) The grey-shaded area indicates the delivery settings for modules ordered from stock. For the sizing of alternative nozzle settings, use Swegon ProSelect, the sizing program that is available at [www.swegon.com](http://www.swegon.com).

2) The specified noise level is applicable to connection without damper or with fully open damper. In other applications that call for throttling by means of a SYST CRPc 9–125 commissioning damper fitted directly to the unit, the required data can be read using the Swegon ProSelect sizing program. Room attenuation = 4 dB

3) The specified capacities are based on operation with the face plate in the high capacity position. Operation with the face plate set to the normal position reduces the water capacity of the Parasol 600 by about 5% and that of the Parasol 1200 by about 10 %.

The water capacity can vary depending on the installation and how the air deflectors are set. The primary air capacity is not affected. N.B.! The total cooling capacity is the sum of the air-based and water-based cooling capacities.



**Table 6 – Data – Cooling Sizing Guide for Parasol 1200 PF units**

Unit length (mm)	Nozzle setting 1)	Primary airflow (l/s)	Sound level in dB(A) 2)	Nozzle pressure $p_i$ (Pa)	Cooling capacity Primary air (W) at $\Delta T_i$				Cooling capacity water (W) at $\Delta T_{mk}$ 3)					Pressure drop constant air/water	
					6	8	10	12	6	7	8	9	10	$k_{pl}$	$k_{pk}$
1200	LLLL	33,6	<20	30	242	323	403	484	332	386	440	489	543	6,13	0,0232
1200	LLLL	43,3	<25	50	312	416	520	624	423	491	566	634	702	6,13	0,0232
1200	LLLL	51,3	30	70	369	492	616	739	484	568	645	722	806	6,13	0,0232
1200	LLLL	54,8	32	80	395	526	658	789	512	592	673	760	840	6,13	0,0232
1200	MMMM	39,5	<20	30	284	379	474	569	358	417	476	535	594	7,21	0,0232
1200	MMMM	51,0	26	50	367	490	612	734	457	530	603	683	755	7,21	0,0232
1200	MMMM	60,3	31	70	434	579	724	868	519	600	689	771	859	7,21	0,0232
1200	MMMM	64,5	33	80	464	619	774	929	540	632	717	810	894	7,21	0,0232
1200	HHHH	48,2	<20	30	347	463	578	694	389	450	512	573	634	8,81	0,0232
1200	HHHH	62,2	26	50	448	597	746	896	483	566	641	716	791	8,81	0,0232
1200	HHHH	73,7	32	70	531	708	884	1061	546	638	722	813	896	8,81	0,0232
1200	HHHH	78,7	34	80	567	756	944	1133	575	662	757	844	939	8,81	0,0232

- 1) For the sizing of alternative nozzle settings, use Swegon’s ProSelect sizing program which is available at [www.swegon.com](http://www.swegon.com)
- 2) The specified sound level is applicable to connection without damper or with fully open damper. In other applications that call for throttling by means of a SYST CRPc 9-160 commissioning damper fitted directly to the unit, the required data can be read using the Swegon ProSelect sizing program.

Room attenuation = 4 dB

3) The specified capacities are based on operation in the high capacity mode. If the face plate is set to the normal position, this will reduce the water capacity of the Parasol 1200 PF by between 5 and 12%.

The water capacity can vary depending on the installation and how the air deflectors are set. The primary air capacity is not affected.

N.B.! The total cooling capacity is the sum of the airborne and waterborne cooling capacities.

**Table 7. Cooling capacity at natural convection**

Unit length (mm)	Cooling capacity (W) for temperature difference, room - water $\Delta T_{mk}$ (K)						
	6	7	8	9	10	11	12
Parasol 600	17	21	25	29	34	39	43
Parasol 1200	41	51	61	72	83	95	107

PARASOL

**Nozzle setting**

The unique built-in nozzle control in the Parasol means that each of the four sides can be set individually. Depending on the unit's location and the room's primary air requirement, the primary air can be guided in all the desired directions. The direction of the airflow can be easily optimized using the Swegon ProSelect sizing program available at [www.swegon.com](http://www.swegon.com).

All the units held in stock are preset to the same nozzle setting on all four sides (for particulars of the delivery settings, see the shaded area in the tables).

The airflow direction can be easily commissioned when installing the unit using the commissioning tools supplied with the unit. This provides logistic advantages since the fitter does not have to take specific room markings into account.

**k-factor (C.O.P.)**

Each nozzle setting has a specific k-factor. A total k-factor for the unit can be determined by adding together the k-factors for the nozzle settings on each side. The relevant k-factor (C.O.P.) for optimized nozzle setting can also be obtained in ProSelect.

**Table 8. K-factor Guide**

Type of unit:	Primary airflow	Side	Nozzle setting	k-factor (C.O.P.)
Parasol 600 MF	Low	Any	L	0,253
	Medium	Any	M	0,44
	High	Any	H	0,693
	None	Any	C	0
Parasol 1200 LF	Low	Short side	L	0,124
	Medium	Short side	M	0,176
	High	Short side	H	0,3
	None	Short side	C	0
	Low	Long side	L	0,328
	Medium	Long side	M	0,464
	High	Long side	H	0,792
	None	Long side	C	0
Parasol 1200 MF	Low	Short side	L	0,176
	Medium	Short side	M	0,253
	High	Short side	H	0,429
	None	Short side	C	0
	Low	Long side	L	0,464
	Medium	Long side	M	0,667
	High	Long side	H	1,131
	None	Long side	C	0
Parasol 1200 HF	Low	Short side	L	0,253
	Medium	Short side	M	0,44
	High	Short side	H	0,693
	None	Short side	C	0
	Low	Long side	L	0,667
	Medium	Long side	M	1,16
	High	Long side	H	1,827
	None	Long side	C	0
Parasol 1200 PF	Low	Short side	L	0,842
	Medium	Short side	M	0,991
	High	Short side	H	1,211
	Min.*	Short side	C	0,556
	Low	Long side	L	2,221
	Medium	Long side	M	2,612
	High	Long side	H	3,192
	Min.*	Long side	C	1,467

*N.B.! Setting C is completely closed, except in Variant PF when a basic flow is always open.*

**Specific nozzle settings**

To specify optimized nozzle settings, always begin from the side where there are water connections. From there, specify side after side in counter-clockwise order, see Figures 21-23. If you like, you can order the units preset from the factory (does not apply to units held in stock).

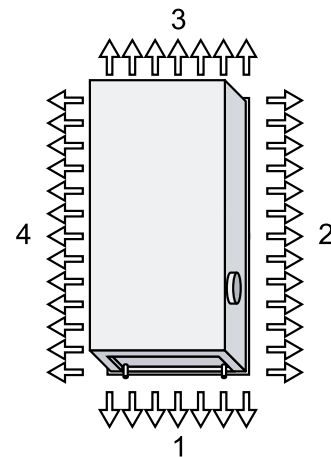
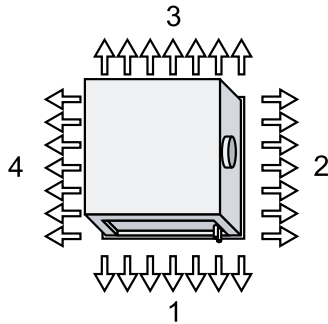
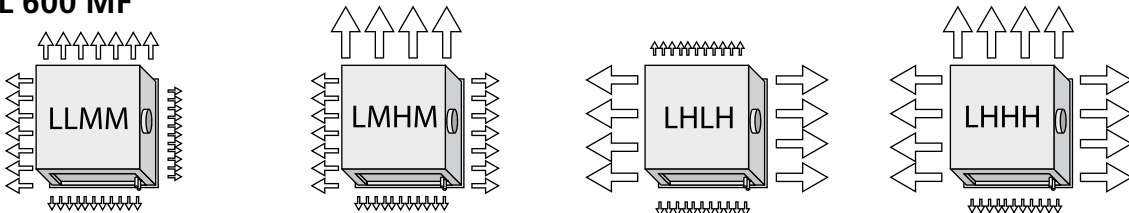

Figure 22. Top view of Parasol 1200, pages 1-4

Figure 21. Top view of Parasol 600, pages 1-4

**PARASOL 600 MF**



**PARASOL 1200 LF, MF, HF**

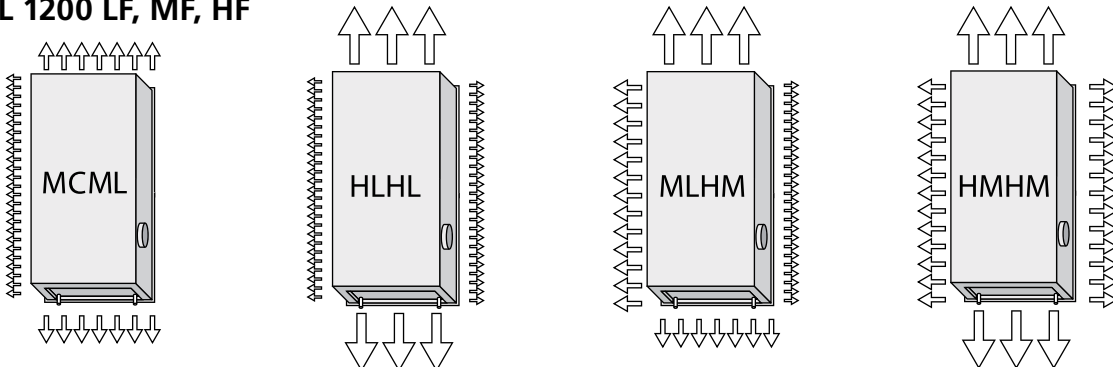

**PARASOL 1200 PF**

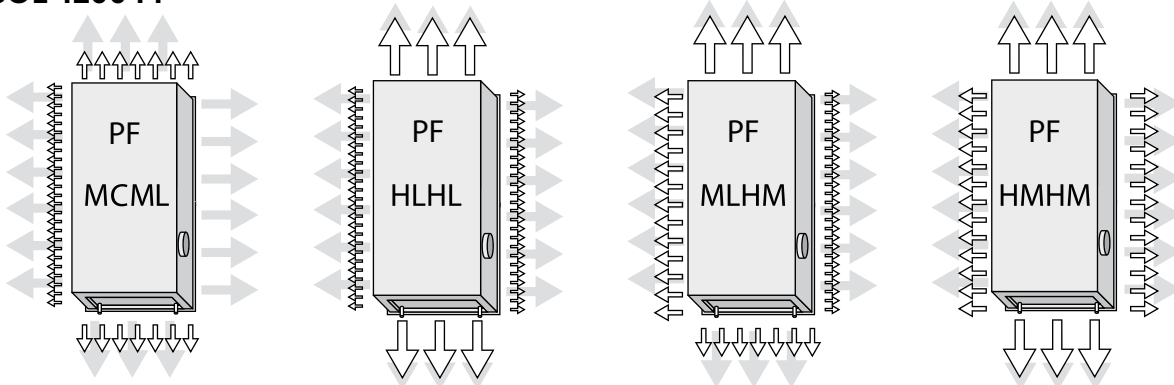

Figure 23. Examples of optimized nozzle setting.

N.B.! Setting C is completely closed, except in Variant PF when a basic flow is always open.

### Calculation Example - Cooling

A cellular office with dimensions  $w \times d \times h = 2.4 \times 4 \times 2.7$  m is to be equipped with comfort modules. The total cooling load is estimated at 50 W/m<sup>2</sup>. To meet this cooling load, a Parasol is required that produces  $50 \times 2.4 \times 4 = 480$  W.

Design room temperature ( $t_r$ ) 24°C, cooling water temperature (flow/return) 14/16°C and the primary air temperature ( $t_i$ ) 16°C produces:

$$\Delta T_k = 2 \text{ K}$$

$$\Delta T_{mk} = 9 \text{ K}$$

$$\Delta T_i = 8 \text{ K}$$

The desired primary air flow to the room ( $q_i$ ) has been fixed at 16 l/s.

The level of flow-generated sound emitted from the unit must not exceed 30 dB(A).

### Solution

#### Cooling

The cooling capacity of the primary air can be calculated using the following formula:  $P_i = 1.2 \cdot \Delta T_i \cdot q_i$

$$P_i = 1.2 \cdot 8 \cdot 16 = 154 \text{ W}$$

The Parasol comfort module must therefore be able to provide  $480 - 154 = 326$  W in cooling capacity on the water side.

From **Table 2** we find that a 592 x 592 mm Parasol with nozzle setting MMMM for a primary airflow of 16 l/s produces 434 W in cooling capacity on the water side. This is sufficient for coping with the cooling load in the room.

#### Cooling Water

With a cooling capacity requirement of 326 W for cooling water, the necessary water flow is obtained in **Chart 1**. A temperature increase of  $\Delta T_k = 2$  K produces a water flow of 0.039 l/s.

In **Chart 2** we can read that a water flow of 0.039 l/s does not produce a fully turbulent outflow, but that the capacity must be corrected by a reduction factor of 0.97. The loss of capacity is compensated by calculating the comfort module's required cooling capacity as follows:  $P_k = 326 / 0.97 = 336$  W.

New water flow from Chart 1,  $q_k = 0.040$  l/s.

The pressure drop is calculated on the basis of a water flow of 0.040 l/s and the pressure drop constant  $k_{pk} = 0.020$ , which is taken from **Table 2**.

The pressure drop can now be read at 4.0 kPa from **Chart 4**.

#### Sound Level

In **Table 2** we see that the sound level with an open damper (or without a damper) reaches 26 dB(A). To see the cut-off range and the current sound level after adjustment with separate type SYST CRPc 9-125 damper, use the Swegon ProSelect sizing program, which is available at [www.swegon.com](http://www.swegon.com).

### Heating

#### Heating function

Because of the comfort module's ability to quickly mix primary air with room air, PARASOL is ideal for providing both cooling and heating. In other words, heating spaces, with air heated above room temperature, from the ceiling is a good alternative to conventional heating by radiators. The benefits achieved include lower installation costs, simpler installation and perimeter walls free from piping and radiators.

Regardless of the type of heating system installed it is important to consider the operative temperature in a room. Most people are comfortable when the operative temperature in winter is in between 20–24°C, and the optimal comfort requirements are normally met when the room temperature is 22°C. This means that for a room with a cold perimeter wall, the air temperature must be higher than 22°C to compensate for the chilling effect. In new buildings with normal insulated perimeter walls and windows that conform to normal standards of glazing, the difference between the room air temperature and the operative temperature is small. But for older buildings with worse windows, it may be necessary to raise the air temperature to compensate for the chilling effect. Different operating scenarios can be simulated easily using the Swegon ProClim Web software where both the room air temperature and operative temperature are specified.

Supplying heated air from the ceiling results in some stratification of the air. With a maximum supply temperature of 40°C, the stratification is non-existent, while at 60°C it can be around 4 K in the occupied zone. This only applies during the warming-up phase, when the room is unused and there is no internal load. When the room is being used and lighting, computers and people are present, the stratification is reduced or disappears depending on the heating load.

Laboratory studies, computer simulations and reference projects all show that a good indoor climate is achieved with the aid of a PARASOL comfort module whatever the time of year.

#### Electric heating

The Parasol variant with electric heating utilizes electric heating elements instead of hot water. The tubular heating elements, situated inside the heating water pipes of the coil, heat the circulated air that passes through the coil. Radiant heat constitutes only a small part of the total heating capacity.

The Parasol with electric heating is available in two capacity variants, see the table below.

Variant	P (W)	I <sub>max</sub> (A)
X1	500	2,2
X2	1000	4,3

**Calculation formulae - water-based heating**

Below are some formulae that enable the user to calculate which comfort module selection is best-suited for the application. The values for the calculations are in Tables 9-13.

**The cooling or heating capacity of the air**

$$P_i = 1,2 \cdot q_i \cdot \Delta T_i$$

- $P_i$  The cooling or heating capacity of the air (W)
- $q_i$  Flow of primary air (l/s)
- $\Delta T_i$  Temperature difference between primary air ( $t_p$ ) and room air ( $t_r$ ) (K)

**Pressure drop for heating circuit (Pa)**

$$\Delta p_v = (q_v / k_{pv})^2$$

- $\Delta p_v$  Pressure drop in heating circuit (kPa)
- $q_v$  Flow of heating water (l/s), see **Chart 6**
- $k_{pv}$  Pressure drop constant for heating circuit, see **Tables 9-13**

**Heating capacity of the water:**

$$P_v = 4186 \cdot q_v \cdot \Delta T_v$$

- $P_v$  Heating capacity of the water (W)
- $q_v$  Flow of heating water (l/s)
- $\Delta T_v$  Temperature difference between the heating water's flow and return flow (K)

**Chart 5. Water Flow – Heating Capacity**

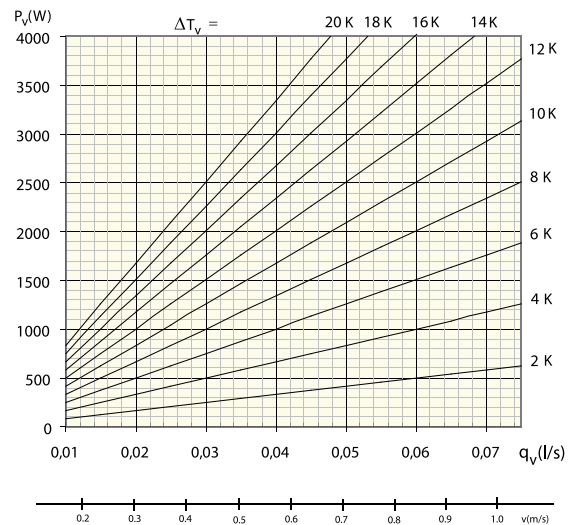

**Chart 6. Pressure Drop – Heating Water Flow**

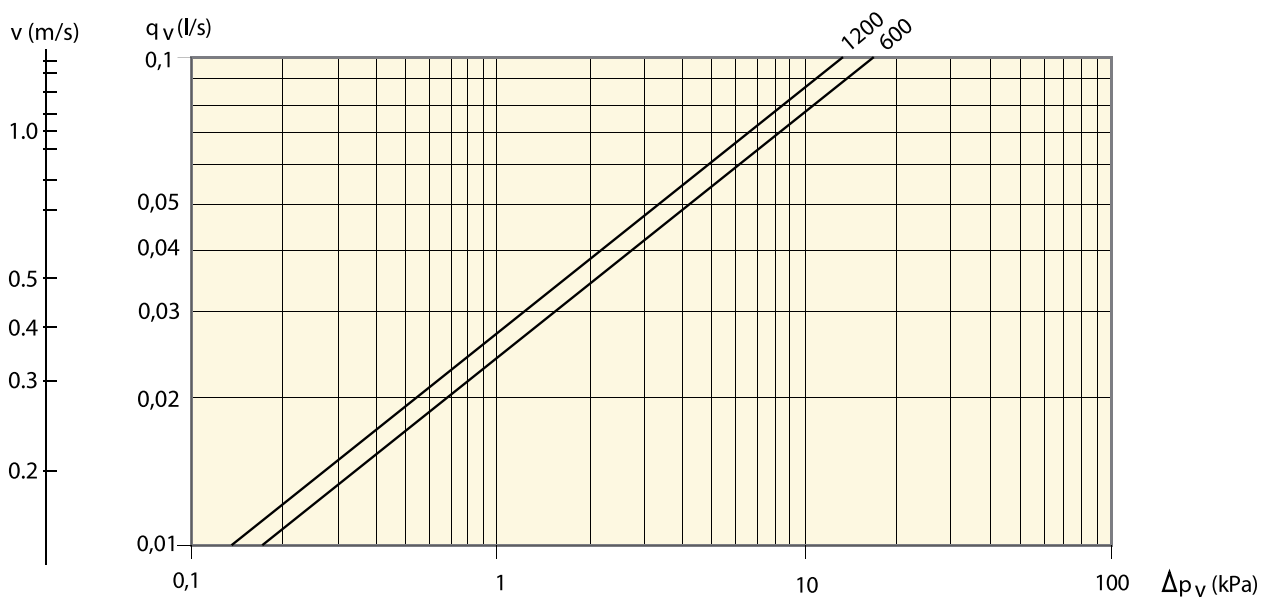

PARASOL

**Table 9 – Data – Heating. Sizing Guide for Parasol MF single-module units**

Unit length (mm)	Nozzle setting (1)	Primary airflow (l/s)	Sound level in dB(A) (2)	Nozzle pressure p <sub>i</sub> (Pa)	Heating capacity water (W) at $\Delta T_{mv}$ (3)							Pressure drop constant air/water	
					5	10	15	20	25	30	35	k <sub>pl</sub>	k <sub>pv</sub>
600	LLLL	7	<20	48	98	196	294	391	488	585	681	1,01	0,0241
600	LLLL	8	<20	62	111	222	332	443	553	662	772	1,01	0,0241
600	LLLL	9	<20	79	123	245	367	488	610	731	852	1,01	0,0241
600	LLLL	10	22	98	133	266	397	529	661	792	924	1,01	0,0241
600	LLLL	12	27	140	150	301	450	600	749	899	1048	1,01	0,0241
600	MMMM	12	<20	47	129	259	377	495	610	724	836	1,76	0,0241
600	MMMM	14	22	63	140	281	413	546	676	806	935	1,76	0,0241
600	MMMM	16	26	83	150	299	445	590	734	877	1020	1,76	0,0241
600	MMMM	18	30	105	158	316	472	629	784	940	1095	1,76	0,0241
600	MMMM	20	33	129	165	331	497	663	829	996	1162	1,76	0,0241
600	HHHH	20	20	52	145	289	426	563	698	832	964	2,77	0,0241
600	HHHH	23	25	69	159	318	470	622	771	920	1067	2,77	0,0241
600	HHHH	26	28	88	172	344	508	673	835	997	1157	2,77	0,0241
600	HHHH	30	33	117	187	374	553	733	909	1086	1262	2,77	0,0241
600	HHHH	34	36	150	200	399	592	785	975	1165	1353	2,77	0,0241

**Table 10 – Data – Heating. Sizing Guide for Parasol LF double-module units**

Unit length (mm)	Nozzle setting (1)	Primary airflow (l/s)	Sound level in dB(A) (2)	Nozzle pressure p <sub>i</sub> (Pa)	Heating capacity water (W) at $\Delta T_{mv}$ (3)							Pressure drop constant air/water	
					5	10	15	20	25	30	35	k <sub>pl</sub>	k <sub>pv</sub>
1200	LLLL	7	<20	60	165	331	494	658	821	985	1148	0,9	0,0273
1200	LLLL	8	<20	78	187	373	558	743	927	1112	1296	0,9	0,0273
1200	LLLL	9	<20	99	205	411	614	818	1021	1224	1427	0,9	0,0273
1200	LLLL	10	<20	122	222	445	665	885	1105	1324	1544	0,9	0,0273
1200	LLLL	11	23	148	238	475	710	946	1180	1415	1649	0,9	0,0273
1200	MMMM	9	<20	49	194	387	565	743	915	1088	1256	1,28	0,0273
1200	MMMM	10	<20	61	207	414	609	805	996	1187	1375	1,28	0,0273
1200	MMMM	12	<20	88	230	460	685	911	1135	1358	1581	1,28	0,0273
1200	MMMM	14	<20	120	250	499	750	1001	1252	1504	1755	1,28	0,0273
1200	MMMM	16	23	156	266	533	806	1079	1354	1629	1906	1,28	0,0273
1200	HHHH	16	<20	54	228	457	683	909	1135	1361	1586	2,18	0,0273
1200	HHHH	18	<20	68	250	501	749	997	1244	1492	1739	2,18	0,0273
1200	HHHH	21	<20	93	279	559	835	1112	1388	1664	1939	2,18	0,0273
1200	HHHH	24	23	121	304	608	910	1211	1512	1812	2112	2,18	0,0273
1200	HHHH	27	26	153	326	652	976	1299	1621	1943	2265	2,18	0,0273

1) The grey-shaded area indicates the delivery settings for modules ordered from stock. For the sizing of alternative nozzle settings, use Swegon ProSelect, the sizing program that is available at [www.swegon.com](http://www.swegon.com).

2) The specified noise level is applicable to connection without damper or with fully open damper. In other applications that call for throttling by means of a SYST CRPc 9–125 commissioning damper fitted directly to the unit, the required data can be read using the Swegon ProSelect sizing program. Room attenuation = 4 dB

3) The specified capacities are based on operation with the face plate in the high capacity position. Operation with the face plate set to the normal position reduces the water capacity of the Parasol 600 by about 5% and that of the Parasol 1200 by about 10 %.

The water capacity can vary depending on the installation and how the air deflectors are set. The primary air capacity is not affected.

N.B.! The total heating capacity is the sum of the air-based and water-based heating capacities.

**Table 11 – Data – Heating. Sizing Guide for Parasol MF double-module units**

Unit length (mm)	Nozzle setting 1)	Primary airflow (l/s)	Sound Level dB(A) 2)	Nozzle pressure p <sub>i</sub> (Pa)	Heating capacity water (W) at $\Delta T_{mv}$ 3)							Pressure drop constant air/water	
					5	10	15	20	25	30	35	k <sub>pl</sub>	k <sub>pv</sub>
1200	LLLL	9	<20	49	203	406	592	778	959	1140	1316	1,28	0,0273
1200	LLLL	10	<20	61	217	434	638	843	1043	1243	1441	1,28	0,0273
1200	LLLL	12	<20	88	241	482	718	954	1189	1423	1657	1,28	0,0273
1200	LLLL	14	<20	120	261	523	786	1048	1312	1575	1839	1,28	0,0273
1200	LLLL	16	22	156	279	558	844	1130	1418	1707	1997	1,28	0,0273
1200	MMMM	13	<20	50	194	389	597	805	1019	1232	1450	1,84	0,0273
1200	MMMM	15	<20	67	227	454	688	922	1159	1396	1635	1,84	0,0273
1200	MMMM	17	<20	85	255	510	767	1024	1281	1538	1797	1,84	0,0273
1200	MMMM	20	23	118	292	584	870	1156	1440	1724	2007	1,84	0,0273
1200	MMMM	22	26	143	314	627	930	1233	1533	1833	2130	1,84	0,0273
1200	HHHH	22	<20	50	250	499	745	991	1236	1481	1725	3,12	0,0273
1200	HHHH	25	<20	64	277	553	826	1099	1370	1642	1912	3,12	0,0273
1200	HHHH	28	22	81	301	601	898	1194	1489	1784	2078	3,12	0,0273
1200	HHHH	33	26	112	336	671	1002	1333	1662	1991	2320	3,12	0,0273
1200	HHHH	38	30	148	366	731	1092	1452	1811	2169	2527	3,12	0,0273

**Table 12 – Data – Heating. Sizing Guide for Parasol HF double-module units**

Unit length (mm)	Nozzle setting 1)	Primary airflow (l/s)	Sound Level dB(A) 2)	Nozzle pressure p <sub>i</sub> (Pa)	Heating capacity water (W) at $\Delta T_{mv}$ 3)							Pressure drop constant air/water	
					5	10	15	20	25	30	35	k <sub>pl</sub>	k <sub>pv</sub>
1200	LLLL	13	<20	50	173	347	645	943	1116	1289	1585	1,84	0,0273
1200	LLLL	15	<20	67	192	384	715	1046	1237	1429	1757	1,84	0,0273
1200	LLLL	17	<20	85	208	417	776	1135	1343	1551	1907	1,84	0,0273
1200	LLLL	20	23	118	230	460	855	1251	1481	1710	2102	1,84	0,0273
1200	LLLL	22	26	143	242	485	902	1319	1561	1803	2217	1,84	0,0273
1200	MMMM	23	<20	52	203	403	756	1106	1308	1511	1857	3,2	0,0273
1200	MMMM	26	23	66	220	440	819	1198	1418	1638	2013	3,2	0,0273
1200	MMMM	30	27	88	240	480	893	1307	1546	1785	2195	3,2	0,0273
1200	MMMM	34	31	113	257	515	958	1401	1658	1915	2354	3,2	0,0273
1200	MMMM	39	35	149	276	553	1029	1505	1781	2057	2528	3,2	0,0273
1200	HHHH	36	26	51	230	461	858	1255	1485	1715	2108	5,04	0,0273
1200	HHHH	40	28	63	247	493	918	1342	1588	1834	2255	5,04	0,0273
1200	HHHH	45	31	80	264	529	984	1440	1704	1968	2419	5,04	0,0273
1200	HHHH	50	34	98	280	561	1044	1527	1807	2087	2566	5,04	0,0273
1200	HHHH	55	36	119	295	590	1098	1606	1900	2195	2698	5,04	0,0273

1) The grey-shaded area indicates the delivery settings for modules ordered from stock. For the sizing of alternative nozzle settings, use Swegon ProSelect, the sizing program that is available at [www.swegon.com](http://www.swegon.com).

2) The specified noise level is applicable to connection without damper or with fully open damper. In other applications that call for throttling by means of a SYST CRPc 9–125 commissioning damper fitted directly to the unit, the required data can be read using the Swegon ProSelect sizing program. Room attenuation = 4 dB

3) The specified capacities are based on operation with the face plate in the high capacity position. Operation with the face plate set to the normal position reduces the water capacity of the Parasol 600 by about 5% and that of the Parasol 1200 by about 10 %.

The water capacity can vary depending on the installation and how the air deflectors are set. The primary air capacity is not affected. N.B.! The total heating capacity is the sum of the air-based and water-based heating capacities.

PARASOL

**Table 13 – Data – Heating. Sizing Guide for Parasol PF double-module units**

Unit length (mm)	Nozzle setting 1)	Primary airflow (l/s)	Sound Level dB(A) 2)	Nozzle pressure p <sub>i</sub> (Pa)	Heating capacity water (W) at $\Delta T_{mv}$ 3)					Pressure drop constant air/water	
					5	10	15	20	25	k <sub>pl</sub>	k <sub>pv</sub>
1200	LLLL	33,6	<20	30	226	433	633	826	1020	6,13	0,0244
1200	LLLL	43,3	<25	50	305	578	849	1114	1371	6,13	0,0244
1200	LLLL	51,3	30	70	352	675	989	1297	1596	6,13	0,0244
1200	LLLL	54,8	32	80	368	711	1045	1367	1686	6,13	0,0244
1200	MMMM	39,5	<20	30	262	497	720	941	1154	7,21	0,0244
1200	MMMM	51	26	50	339	640	936	1220	1501	7,21	0,0244
1200	MMMM	60,3	31	70	384	733	1066	1398	1720	7,21	0,0244
1200	MMMM	64,5	33	80	405	768	1121	1468	1804	7,21	0,0244
1200	HHHH	48,2	<20	30	277	522	756	981	1201	8,81	0,0244
1200	HHHH	62,2	26	50	354	674	985	1290	1585	8,81	0,0244
1200	HHHH	73,7	32	70	407	775	1133	1485	1833	8,81	0,0244
1200	HHHH	78,7	34	80	423	812	1192	1559	1929	8,81	0,0244

1) For particulars on the sizing of alternative nozzle settings, use Swegon’s ProSelect sizing program available at [www.swegon.com](http://www.swegon.com)

2) The specified sound level applies to connection without damper or with fully open damper. For other applications that call for throttling by means of a SYST CRPc 9-160 commissioning damper fitted directly to the unit, the required data can be read using the Swegon ProSelect sizing program.

Room attenuation = 4 dB

3) The specified capacities are based on operation in the high capacity mode. If the face plate is set to the normal position, this will reduce the water capacity of the Parasol 1200 PF by between 5 and 12%.

The water capacity can vary depending on the installation and how the air deflectors are set. The primary air capacity is not affected.

N.B. ! The total heating capacity is the sum of the airborne and waterborne heating capacities. If the primary air temperature is lower than the room temperature, it causes negative impact on the total heating capacity.



### Calculation Example - Heating

In a cellular office with dimensions  $w \times d \times h = 2.4 \times 4 \times 2.7$  m (the same room as in the example for cooling), in the wintertime, there is also a heating requirement of 480 W. The primary air flow must be the same as in the summer scenario: 16 l/s.

Design room temperature ( $t_r$ ) 22°C, heating water temperature (flow/return) 45/39°C and the primary air temperature ( $t_p$ ) 20°C produces:

$$\Delta T_v = 6 \text{ K}$$

$$\Delta T_{mv} = 20 \text{ K}$$

$$\Delta T_i = -2 \text{ K}$$

### Solution

#### Heating

The primary airflow of 16 l/s in combination with the primary air temperature of 20°C produces a negative impact on the heating capacity:  $1.2 \times 16 \times (-2) = -38$  W. The heating capacity required from the heating water is thus increased to  $480 + 38 = 518$  W. From **Table 9** at  $\Delta T_{mv} = 20$  K and primary air volume 16 l/s we obtain a heat capacity of  $P_v = 590$  W from a single-module unit, which is sufficient to meet the heating requirements.

#### Heating Water

With a heating requirement of 518 W and  $\Delta T_v = 6$  K, we obtain the required water flow from **Chart 5**: 0.021 l/s. The pressure drop for the heating water is calculated on the basis of a water flow of 0.021 l/s and pressure drop constant  $k_{pv} = 0.0241$ , which is taken from Table 9. The pressure drop will then be:  $\Delta p_v = (q_v/k_{pv})^2 = (0.021 / 0.0241)^2 = 0.76$  kPa. Alternatively, the pressure drop can be read off from **Chart 6**.

#### Electric heating

The 488 W heating load can also be met with Parasol electric heating variant X1, which generates 500 W of heating capacity.

ACOUSTICS

Initial Adjustment Range

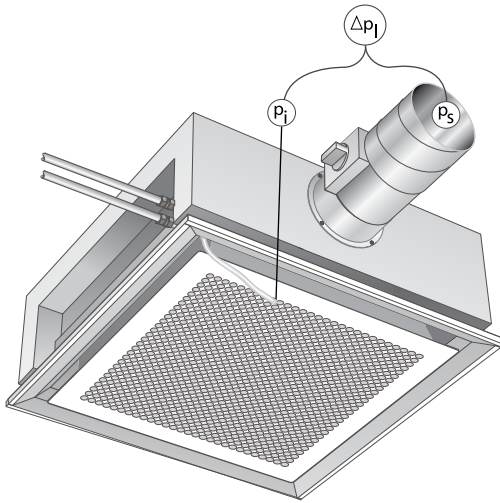

Figure 24. Pressure Conditions - Air

Damper throttling range

$$\Delta p_1 = p_i \cdot p_s$$

- $\Delta p_1$  Throttling range of fitted damper  $p_s - p_i$ , see **Chart 7-8**
- $p_i$  Nozzle pressure (easily measured with a manometer connected to measurement hoses).
- $p_s$  Static pressure before the the unit and damper

Chart 7. Adjustment range, CRPc 9-125 damper

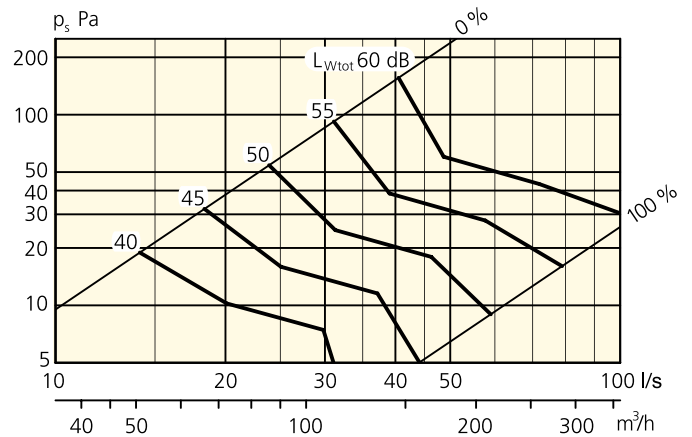

The chart show the total generated sound power ( $L_{Wtot}$  dB), as a function of the airflow and pressure drop across the damper. By correcting  $L_{Wtot}$  with the correction factors from Table 20, the sound power levels for the corresponding octave bands can be obtained ( $L_W = L_{Wtot} + K_{ok}$ ).

Chart 8. Adjustment range, CRPc 9-160 damper

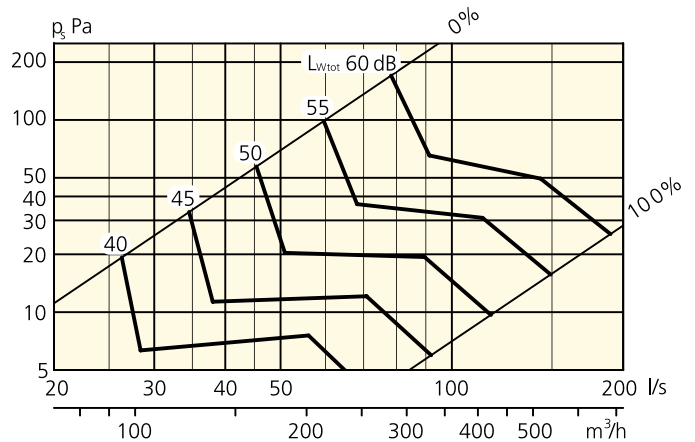

The chart show the total generated sound power ( $L_{Wtot}$  dB), as a function of the airflow and pressure drop across the damper. By correcting  $L_{Wtot}$  with the correction factors from Table 21, the sound power levels for the corresponding octave bands can be obtained ( $L_W = L_{Wtot} + K_{ok}$ ).

**Table 14. Cross-talk**

Typical  $R_w$  values between offices with Parasol where the partition wall finishes at the suspended ceiling (with a good seal). It is assumed that the partition wall has at least the same  $R_w$  value as in the table.

Design	Suspended Ceiling $R_w$ (dB)	With Parasol $R_w$ (dB)
Light acoustic suspended ceiling. Mineral wool or perforated steel/ aluminium coffers or screen.	28	28
Light acoustic suspended ceiling. Mineral wool or perforated steel/ aluminium coffers or screen. Suspended ceiling is covered with 50 mm mineral wool*.	36	36
Light acoustic suspended ceiling. Mineral wool or perforated steel/ aluminium coffers or screen. Upright 100 mm mineral wool panel forming the seal between the offices*.	36	36
Perforated plaster panels in T-section grid system. Acoustic insulation on top side (25 mm).	36	36
Sealed plaster suspended ceiling with insulation on top side.	45	44
* Rockwool 70 kg/m <sup>3</sup> , Gullfiber 50 kg/m <sup>3</sup> .		

**Orifice Attenuation and End Reflection**

Orifice attenuation  $\Delta L$  (dB) including end reflection.

**Table 15. Orifice Attenuation  $\Delta L$  (dB) Parasol 600 MF**

Nozzle setting	Octave band (Hz)							
	63	125	250	500	1k	2k	4k	8k
LLLL	19	20	17	16	17	16	15	15
MMMM	17	18	15	14	15	14	13	13
HHHH	15	16	13	12	13	12	11	11

**Table 16. Orifice Attenuation  $\Delta L$  (dB) Parasol 1200 LF**

Nozzle setting	Octave band (Hz)							
	63	125	250	500	1k	2k	4k	8k
LLLL	19	20	17	16	17	16	15	15
MMMM	18	19	16	15	16	15	14	14
HHHH	15	16	13	12	13	12	11	11

**Table 17. Orifice Attenuation  $\Delta L$  (dB) Parasol 1200 MF**

Nozzle setting	Octave band (Hz)							
	63	125	250	500	1k	2k	4k	8k
LLLL	18	19	16	15	16	15	14	14
MMMM	16	17	14	13	14	13	12	12
HHHH	14	15	12	11	12	11	10	10

**Table 18. Orifice Attenuation  $\Delta L$  (dB) Parasol 1200 HF**

Nozzle setting	Octave band (Hz)							
	63	125	250	500	1k	2k	4k	8k
LLLL	16	17	14	13	14	13	12	12
MMMM	14	15	12	11	12	11	10	10
HHHH	12	13	10	9	10	9	8	8

**Table 19. Orifice Attenuation  $\Delta L$  (dB) Parasol 1200 PF**

Nozzle setting	Octave band (Hz)							
	63	125	250	500	1k	2k	4k	8k
LLLL	19	15	11	7	7	8	13	16
MMMM	19	15	11	7	7	8	13	16
HHHH	19	15	11	7	7	8	13	16

**Table 20. Sound power level for CRPc 9-125 damper, Correction factor,  $K_{ok}$**

Size	Mid-frequency (Octave band) Hz							
	63	125	250	500	1k	2k	4k	8k
CRPc 9	63	125	250	500	1k	2k	4k	8k
125	0	-2	-9	-15	-20	-25	-29	-35
Tol. $\pm$	2	2	2	2	2	2	2	2

**Table 21. Sound power level for CRPc 9-160 damper, Correction factor,  $K_{ok}$**

Size	Mid-frequency (Octave band) Hz							
	63	125	250	500	1k	2k	4k	8k
CRPc 9	63	125	250	500	1k	2k	4k	8k
160	0	-2	-12	-16	-18	-21	-26	-36
Tol. $\pm$	2	2	2	2	2	2	2	2

### Dimensions

Unit	Length of the unit (mm)	Width W (mm)
Parasol 600	584; 592; 598; 617; 623; 642; 667	584; 592; 598; 617; 623; 642; 667
Parasol 1200	1184; 1192; 1198; 1242; 1248; 1292; 1342	584; 592; 598; 617; 623; 642; 667

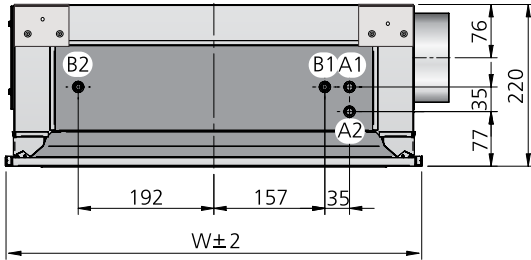

Figure 25. Parasol 600, end view and connections

A1 = Inlet, cooling water Ø12x1.0 mm (Cu)  
 A2 = Return, cooling water Ø12x1.0 mm (Cu)  
 B1 = Inlet, heating water Ø12x1.0 mm (Cu)  
 B2 = Return, heating water Ø12x1.0 mm (Cu)

**Important:**

For the single-module unit, it is important that the cooling water is connected correctly to the connection pipe. The flow direction is essential to obtain full cooling capacity. **The water flow and return direction are indicated on the end of the unit by means of arrows.**

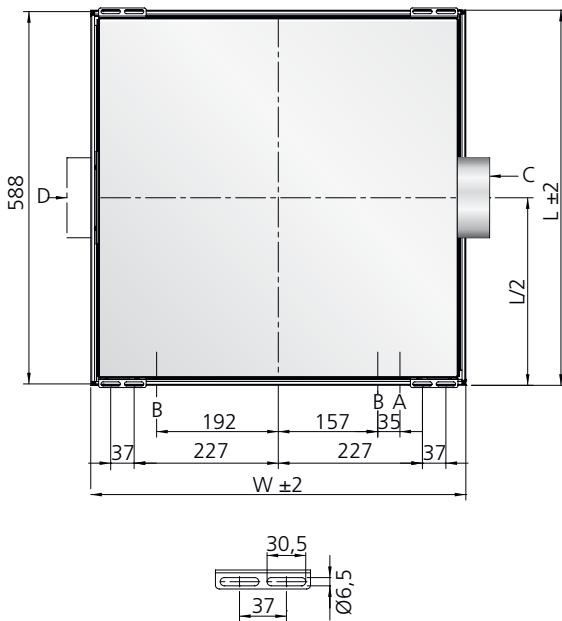

Figure 26. Parasol 600, top view

A = Inlet and return, cooling water Ø12x1.0 mm (Cu)  
 B = Inlet and return, heating water Ø12x1.0 mm (Cu)  
 C = Connection piece for primary air Ø125 mm  
 D = Capped alternative air connection

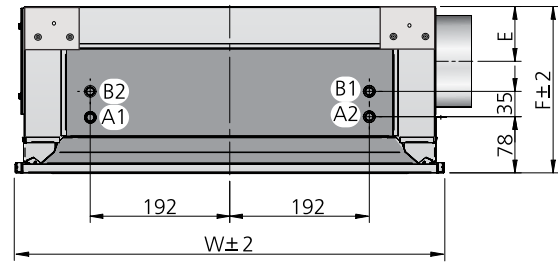

Figure 27. Parasol 1200, end view and connections

A1 = Inlet, cooling water Ø12x1.0 mm (Cu)  
 A2 = Return, cooling water Ø12x1.0 mm (Cu)  
 B1 = Inlet, heating water Ø12x1.0 mm (Cu)  
 B2 = Return, heating water Ø12x1.0 mm (Cu)

Parasol 1200 LF; MF; HF	Parasol 1200 PF
E = 76 mm	92 mm
F = 220 mm	240 mm

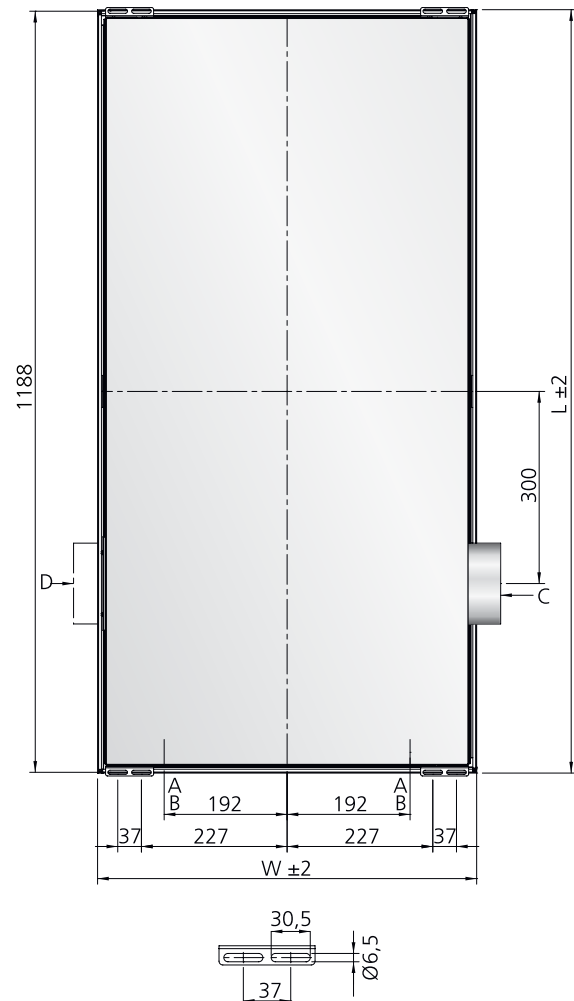

Figure 28. Parasol 1200, top view

A = Inlet and return, cooling water Ø12x1.0 mm (Cu)  
 B = Inlet and return, heating water Ø12x1.0 mm (Cu)  
 C = Connection piece for primary air Ø125 mm (PF = 160 mm)  
 D = Capped alternative air connection

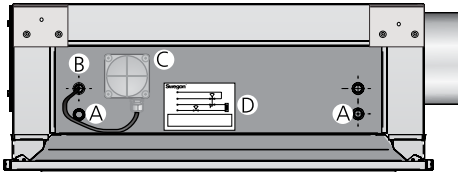

Figure 29. Parasol 1200 for electric heating, viewed from end panel and connections

- A = Cooling water supply and return, Ø12x1.0 mm (Cu)
- B = Electric heating element
- C = Terminal box for connecting to mains power supply
- D = Wiring diagram – electrical connections

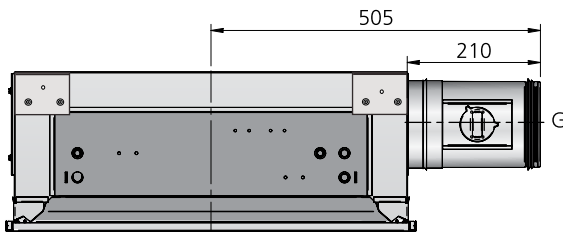

Figure 30. Connection with damper, end view

G = Adjustment damper fitted SYST CRPc 9-xxx

Parasol 600 MF	G = Ø125
Parasol 1200 LF; MF, HF	G = Ø125
Parasol 1200 PF	G = Ø160

If the sound levels specified are to apply, it is important that the damper is fitted with the dial pointing left viewed in the direction of primary airflow.

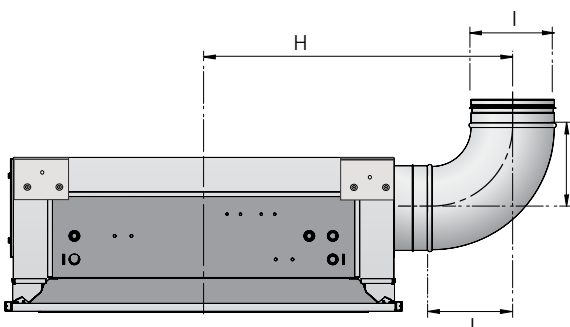

Figure 31. Connection with bend, end view

Connection piece fitted SYST CA xxx-90

Parasol 600 MF	H = 460 I = 125
Parasol 1200 LF; MF, HF	H = 460 I = 125
Parasol 1200 PF	H = 495 I = 160

## Ordering Key

### Contractor demarcation

Swegon's delivery ends at the connection points for water and air, and the connection of indoor climate control equipment. (see **Figures 20, 26 and 28**).

- The pipe contractor connects the connections points for water to the plain pipe end and fills the system, bleeds it and tests the pressure. If the indoor environment control system is fitted at the factory, the return pipe for chilled water and heating is connected directly to the valve. (DN ½" male threads).
- The ventilation contractor connects ducting to the air connection piece.
- The electrical contractor connects power (24V) and signal cables to the connection card with spring connections. The max. permissible cable cross-section is 2.5 mm<sup>2</sup>. For safe operation, we recommend finished cable ends.

### Available to order, Parasol

Size	Single-module unit: 584 x 584 mm 592 x 592 mm 598 x 598 mm 617 x 617 mm 623 x 623 mm 642 x 642 mm 667 x 667 mm  Double-module unit: 1184 x 584 mm 1192 x 592 mm 1198 x 598 mm 1242 x 617 mm 1248 x 623 mm 1292 x 642 mm 1342 x 667 mm The tolerance is ±2 mm.
Function	The units can be ordered in various functional versions:  A = Cooling and supply air B = Cooling, heating and supply air C = Supply air only X1* = Electric heating, 500 W, cooling and supply air X2* = Electric heating, 1000 W, cooling and supply air  * Applicable to the two-module unit only.
ADC <sup>II</sup>	Factory-fitted ADC <sup>II</sup> is supplied as standard
Airflow variant	Single-module unit: MF (medium flow)  Double-module unit: LF (low flow) MF (medium flow) HF (high flow) PF (PlusFlow, extra high airflow)
Nozzle setting	Each side can be set in four different ways: L, M, H or C  L = Low airflow M = Medium airflow H = High airflow C = No airflow* * For Variant PF, nozzle setting C is not completely closed.
Colour	The units are supplied painted in Swegon standard shade of white RAL 9010, gloss ratio 30 ± 6%

### Ordering Key, Parasol 600

Parasol	Parasol b	aaa-	b-	MF-	cdef
Version:					
Size (mm): 584; 592; 598; 617; 623; 642; 667					
Function: A = Cooling and supply air. B = Cooling, heating and supply air C = Supply air only					
Nozzle setting: Side 1: L; M; H; C Side 2: L; M; H; C Side 3: L; M; H; C Side 4: L; M; H; C					

### Ordering Key, Parasol 1200 PF

Parasol	Parasol b	aaaa-	b-	PF-	defg
Version:					
Size (mm): 1184; 1192; 1198; 1242; 1248; 1292; 1342					
Function: A = Cooling and supply air. B = Cooling, heating and supply air					
Airflow variant PF = PlusFlow					
Nozzle setting: Side 1: L; M; H; C Side 2: L; M; H; C Side 3: L; M; H; C Side 4: L; M; H; C					

### Ordering Key, Parasol 1200

Parasol	Parasol b	aaaa-	b-	cc-	defg
Version:					
Size (mm): 1184; 1192; 1198; 1242; 1248; 1292; 1342					
Function: A = Cooling and supply air B = Cooling, heating and supply air C = Supply air only X1 = Electric heating, 500 W, cooling and supply air X2 = Electric heating, 1000 W, cooling and supply air					
Airflow variant LF = Low flow MF = Medium flow HF = High flow					
Nozzle setting: Side 1: L; M; H; C Side 2: L; M; H; C Side 3: L; M; H; C Side 4: L; M; H; C					

PARASOL

**Available to order, Accessories**

Perforation patterns	Perforation patterns are available in three different versions.
Room control kit	CONDUCTOR or LUNA Control equipment
Flexible connection hose	Connection hose is supplied with clamping ring coupling, push-on coupling or sleeve nut.
Assembly piece	Ceiling mount and threaded rod for ceiling mounting. Double threaded rods with thread lock also available.
Plasterboard ceiling frame	Plasterboard ceiling frame for single-module and double-module units.
Connection piece, air	The connection pieces are either straight or 90° angular.
Initial adjustment damper	Initial adjustment damper, can be ordered if needed.
Tool for nozzle adjustment	One tool for nozzle adjustment is supplied with each order free of charge. Several tools must be specified separately.
Venting nipple	Venting nipple with push-on coupling for connection to return pipe for water.

**Table 22. The components included in the optional control system kit that is available for the Parasol**

Designation	Factory-fitted	Condensation sensor	Valve	Actuator	Controller			Room unit RU	Pressure sensor
					W1	W4.1	W4.2		
PARASOL b T-CG	Ja	1							
PARASOL b T-COND-W1-C	Ja	1	1	1	1		1		
PARASOL b T-COND-W1-C-SLAVE	Ja		1	1					
PARASOL b T-COND-W1-CH	Ja	1	2	2	1		1		
PARASOL b T-COND-W1-CH-SLAVE	Ja		2	2					
PARASOL b T-COND-W4-C-SLAVE	Ja		1	1					
PARASOL b T-COND-W4.1-C-SA1	Ja	1	1	1		1	1	1	
PARASOL b T-COND-W4.2-C-SA1	Ja	1	1	1			1	1	
PARASOL b T-COND-W4.1-CH-SA1	Ja	1	2	2		1	1	1	
PARASOL b T-COND-W4.2-CH-SA1	Ja	1	2	2			1	1	
PARASOL b T-COND-W4-PS	Ja							1	
PARASOL b T-COND-W4.2-C-SA2	Ja		1	1				1	
PARASOL b T-COND-W4.2-CH-SA2	Ja		2	2				1	
PARASOL b T-COND-W4-CH-SLAVE	Ja		2	2					
PARASOL b T-RK-LUNA-C	Ja	1	1	1					
PARASOL b T-RK-LUNA-C-KIT	Nej	1	1	1					
PARASOL b T-RK-LUNA-CH	Ja	1	2	2					
PARASOL b T-RK-LUNA-CH-KIT	Nej	1	2	2					
SYST RK-LUNA-C	Nej		1	1					
SYST RK-LUNA-CH	Nej		2	2					



**Factory-fitted controls kit, optional**

Control equipment PARASOL b T-COND- W1- aa  
 factory-fitted  
 Version:  
 Type of controls = CONDUCTOR  
 Application W1  
 For CAV systems  
 Functions  
 C = Cooling  
 CH = Cooling and heating

Control equipment PARASOL b T-RK-LUNA- aa  
 factory-fitted  
 Version:  
 Type of controls = LUNA  
 Functions:  
 C = Cooling  
 CH = Cooling and heating

Factory-fitted condensation sensor PARASOL b T-CG

Factory-fitted tPressure sensor PARASOL b T-COND-W4-PS

Control equipment PARASOL b T-COND- W4.1- aa- SA1  
 factory-fitted  
 Version:  
 Type of controls = CONDUCTOR  
 Application W4  
 For DCV systems  
 Functions:  
 C = Cooling  
 CH = Cooling and heating  
 Supply air branch duct no. 1

Control equipment PARASOL b T-COND- W4.2- aa- bbb  
 factory-fitted  
 Version:  
 Type of controls = CONDUCTOR  
 Application W4  
 For DCV systems  
 Functions:  
 C = Cooling  
 CH = Cooling and heating  
 Supply air branch duct:  
 SA1 = Supply air branch duct no. 1  
 SA2 = Supply air branch duct no. 2

Control equipment PARASOL b T-COND- aa- bb- SLAVE  
 factory-fitted  
 Version:  
 Type of controls = CONDUCTOR  
 Application:  
 W1  
 W4  
 Functions:  
 C = Cooling  
 CH = Cooling and heating

PARASOL

**Separate controls kit, optional (not factory-fitted)**

Control equipment kit	PARASOL b	T-RK-LUNA-	aa-	KIT
Version:				
Type of controls = LUNA				
Functions:				
C = Cooling				
CH = Cooling and heating				
KIT = separate delivery as a kit				

Control equipment kit	SYST	RK-LUNA-	aa
Type of controls = LUNA			
Functions:			
C = Cooling			
CH = Cooling and heating			

Example 1:

PARASOL without control equipment

PARASOL b 592-B-MMMM

Example 2:

PARASOL with CONDUCTOR W4 factory-fitted climate control equipment for cooling, heating and demand-control of the supply air in supply air branch duct no. 1

PARASOL b 592-B-MMMM

PARASOL b T-COND-W4.1-CH-SA1

### Ordering Key, Accessories

Perforation pattern	Parasol b	T- PP-	a-	bb
Version:				
Type:				
1 = Parasol 600				
2 = Parasol 1200				
Perforation variant:				
PD				
PE				

Flexible connection hose	SYST FH F1-	aaa-	12
Clamping ring coupling (Ø12 mm) against pipe on both ends (1 pc)			
Length (mm)			
300; 500 or 700			

Flexible connection hose	SYST FH F20-	aaa-	12
Quick-fit coupling (push-on, Ø12 mm) against pipe on both ends (1 pc)			
Length (mm):			
275; 475 or 675			

Flexible connection hose	SYST FH F30-	aaa-	12
Quick-fit coupling (push-on, Ø12 mm) against pipe on one end, G20ID sleeve nut on the other end (1 pc)			
Length (mm):			
200; 400 or 600			

Assembly piece	SYST MS M6-	aaaa-	b-	RAL 9010
Length of threaded rod				
200; 500; 1000				
Type:				
1=One threaded rod				
2=Two threaded rods and one thread lock				

Plasterboard ceiling frame	Parasol b	T- FPB-	aaaa
Version:			
Length (mm):			
592; 1192			

Connection piece, air	SYST AD-	aaa
Ø mm		
125		
160 (PARASOL PF)		

Connection piece (90° bend), air	SYST CA-	aaa-	90
Ø mm			
125			
160 (PARASOL PF)			

Initial adjustment damper	SYST CRPc 9-	aaa
Ø mm		
125		
160 (PARASOL PF)		

Tool for Nozzle adjustment SYST TORX 6-200

Venting nipple SYST AR-12

PARASOL

## Examples

The following examples show how to fill in various specifications.

First of all, use the ProSelect program or the calculation formulae and tables to calculate which dimensions the units should have to meet the requirements

### Sample order 1

After sizing, it has been decided that a Parasol comfort module unit with dimensions 592 x 592 would suit a given cellular office. It has already been decided that radiators should be installed to provide the heating requirement, so a unit with coil heating is not necessary. In the design, a diffusion pattern has been selected in which an equal amount of air is discharged in all four directions at nozzle setting M to provide the desired air volume. There is no special preference with regard to perforation pattern. To minimize the installation period, factory-fitted indoor climate control equipment is desired. The accessories required in this example are one initial adjustment damper and a 500 mm assembly piece.

### Ordering Keys

Parasol b 592-A-MF-MMMM

Parasol b T-RK-LUNA-C

SYST CRPc 9-125

SYST MS M6 500-1

### Sample order 2

In an open-plan office eight Parasol comfort module units in the high-flow version are required with standard dimensions 1192 x 592 mm to meet the cooling requirement. Earlier in the project, the team selected a suspended ceiling system with a c-c distance of 675 mm between the T-sections. The product dimensions 1342 x 667 mm are ideal for this suspended ceiling system. The perimeter wall has a low U-value, with triple-glazed windows providing good insulation. Bearing this in mind, comfort module units with coil heating have been selected. Four of the comfort modules are located close to partition walls. To further play safe against potential draught issues, the diffusion pattern for these units is adapted so that only a smaller volume of air is directed towards the partition walls. The architect has chosen the PD perforation pattern in the face plate. Other accessories selected are an initial adjustment damper and assembly piece with 1000 mm long threaded rods.

### Specification

4 Parasol b 1342-B-HF-MMMM

2 Parasol b 1342-B-HF-MLMM

2 Parasol b 1342-B-HF-MMML

8 Parasol b T-PP-2-PD

8 SYST CRPc 9-125

8 SYST MS M6 1000-1

## Ordering example 3

In a conference room designed for 12 persons and outfitted with a 600 mm centre-to-centre false ceiling, the client has decided to place one PARASOL b 1192-B-PF and one PARASOL b 1192-A-PF module to meet cooling capacity, heating capacity and airflow rate requirements.

To obtain maximum air distribution, the nozzle strips are set to fully open setting HHHH.

By setting the ADC air deflectors in a fan-shape configuration, one maximizes the air mixing zone and in this way minimizes any risk of occupants feeling a draught in the room.

Since the number of occupants in any given conference room varies, and in this case we only want to ventilate when the room is in use, it has been decided that demand-controlled ventilation will be used.

An energy-efficient solution is achieved by using the CONDUCTOR W4.2, where two separate supply air dampers supply each Parasol with a separate airflow for demand-controlled ventilation.

The control system is ordered factory-wired since the client wants to minimize the installation time as in Example 1.

Extract air is taken through a transfer air grille to the corridor.

### Ordering key

1 PARASOL b 1192-B-PF-HHHH

1 PARASOL b 1192-A-PF-HHHH

1 PARASOL b T-COND-W4.2-CH-SA1

1 PARASOL b T-COND-W4.2-C-SA2

2 CRTc -160-2

2 SYST MS M6 500-1

2 CLA-A 160-500

## Specification text

Example of a specification text conforming to VVS AMA Standard.

KB XX

Swegon Parasol comfort module for integrated installation in suspended ceilings, with the following functions:

- Cooling (optional)
- Heating, water (optional)
- Heating, electric (optional)
- Ventilation
- Adjustable air direction
- ADC<sup>II</sup> Indoor climate comfort control
- Integrated circulating air opening in face plate
- Enclosed version for circulating air
- Cleanable air duct
- Fixed measurement tapping with hose
- Painted in base shade of white RAL 9010
- Suitable for T-grid systems with modular dimensions: 600; 625; and 675 mm; T-section: 24 mm (optional)
- Contractor demarcation at the connection points for water and air according to dimensional drawings
- Contractor demarcation for electric connection point according to dimensional drawings
- At connection points pipe contractor connects to plain pipe end Ø12 mm (cooling) or Ø12 mm (heating). If the unit is fitted with indoor climate control equipment, pipe contractor connects to external thread DN 1/2". Ventilation contractor connects ducting to connection piece Ø125 mm (Parasol 1200 PF = Ø160 mm)
- Pipe contractor fills, bleeds, tests the pressure and assumes responsibility for the design water flows reaching each branch of the system and the index unit
- Ventilation contractor conducts initial adjustment of the airflows

## Accessories:

- Alternative perforation pattern, Parasol b T-PP-a-bb, xx qty
- Factory-fitted room climate control system:
  - o Parasol b T-COND-W1-aa, xx pcs.
  - o Parasol b T-COND-W4.1-aa-SA1, xx pcs
  - o Parasol b T-COND-W4.2-aa-bbb, xx pcs
  - o Parasol b T-COND-aa-bb-SLAVE, xx pcs
  - o Parasol b T-RK-LUNA-aa, xx pcs
  - o Parasol b T-CG, xx pcs
  - o Parasol b T-COND-W4-PS, xx pcs
- Separate climate control equipment (kit):
  - o Parasol b T-RK-LUNA-aa-KIT, xx pcs.
  - o SYST RK-LUNA-aa, xx pcs.
- Air connection piece, SYST AD-aaa, xx qty
- Flexible connection hose, SYST FH aaa- bbb- 12, xx qty
- Assembly piece, SYST MS M6 aaaa-b-RAL 9010, xx qty
- Connection piece (90°duct bend), SYST CA aaa-90, xx qty
- Adjustment damper SYST CRPc 9-aaa, xx qty
- Plaster ceiling frame, Parasol b T-FPB-aaaa
- Size:
  - KB XX-1 Parasol b aaa-b-MF-cdef, xx qty
  - KB XX-2 Parasol b aaaa-b-cc-defg, xx qty.
  - KB XX-3 Parasol b aaaa-b-PF-defg, xx qty. etc
- For more information about the climate control equipment, see the separate sections in the Water-borne Climate Systems catalogue or visit our website: [www.swegon.com](http://www.swegon.com)