

# PARAGON b

Compact comfort module



PARAGON b

## Comfort module PARAGON

PARAGON is the name of a new family of compact comfort modules designed especially for use in hotels and hospitals.

PARAGON provides high cooling/heating capacity through optimal utilization of its cooling/heating coil at low air pressure and airflows. At the same time, the installation height of the product is kept to an absolute minimum which enables the entrance of a room to reach maximum height.

### Quick facts

- ▶ Cooling, heating and ventilation
- ▶ Low installation height
- ▶ High capacity
- ▶ Simple installation
- ▶ Closed system
- ▶ Adjustable airflow rate
- ▶ Adjustable direction of air discharge

### Key figures

Airflow range: 21 - 153 cfm  
 Pressure range: 0.2 – 0.8 inWG  
 Total cooling capacity: Up to 8200 Btuh\*  
 Heating capacity – water: Up to 10200 Btuh\*\*  
 Size: Length = 35, 43, 51 and 59 in.  
 Depth = 27 in.  
 Height = 7 in.

Length	Primary air (cfm)	Nozzle pressure (inWG)	Noise level, dB(A)	Cooling capacity (Btuh) *	Heating capacity (Btuh) **
43	40	0.4	<20	2935	4778
43	66	0.8	28	4283	6536

\* Applies to  $\Delta T_l$  and  $\Delta T_{mk}$  18 °F

\*\* Applies to  $\Delta T_{mv}$  72 °F





Figure 1. PARAGON

## Technical description

### Outstanding features of the PARAGON comfort module

The PARAGON is designed to create an optimal indoor climate for hotel rooms and hospital patient rooms. For these applications, PARAGON delivers a high-degree of comfort and offers low operating costs. Since the PARAGON is driven by a central air handling unit, it has no built-in fan that may generate noise and require servicing. The built-in coil of the unit is utilized optimally (through patent-pending technology) to provide high cooling and heating capacity at low air pressure airflows. The optimal use of the coil also minimizes the height of the unit. This allows for a higher ceiling in the entrance of a room, making it more bright and spacious.

### PARAGON in a nutshell

- Low flow-generated noise level
- Draft-free indoor climate
- No fan in the room
- Dry system without condensation
- No need for any drainage system
- No filters
- Requires minimal maintenance
- Low energy consumption
- Flexible adjustment of the air volume (VariFlow)
- Guaranteed comfort through flexible adjustment of the direction of air discharge (ADC<sup>II</sup>)

## How the Unit Operates

### Hotel & Hospital

The primary air is supplied through a duct connection in the rear edge of the unit and this builds up positive pressure inside the unit. The positive pressure distributes the primary air at relatively high velocity via two rows of nozzle holes, one row in the upper edge and one row in the lower edge of the outlet. The high velocity of the primary air creates negative pressure which generates induction of the room air. The recirculation air is drawn up through the recirculation grille of the unit and flows on through the coil where it is cooled, heated, if required, or just passes untreated, before it mixes with the primary air and is discharged into the room.

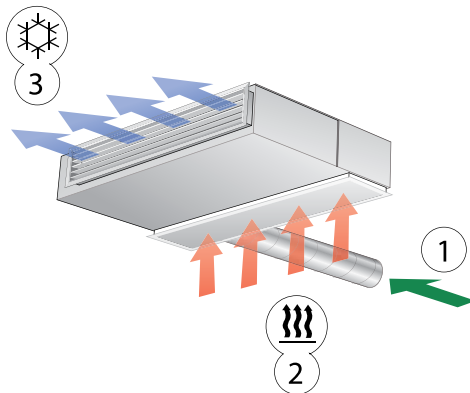

Figure 2. PARAGON cooling function  
 1 = Primary air  
 2 = Induced room air  
 3 = Primary air mixed with chilled room air

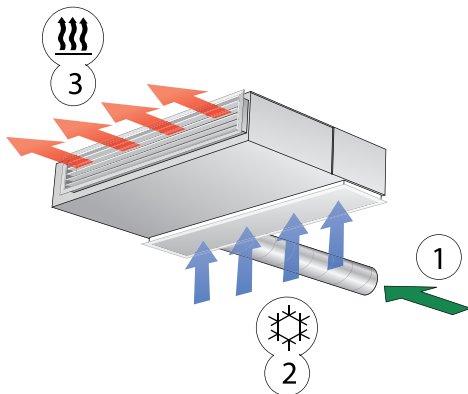

Figure 3. PARAGON heating function  
 1 = Primary air  
 2 = Induced room air  
 3 = Primary air mixed with heated room air

The supply air discharged into hotel rooms and hospital patient rooms is distributed as straight as possible by allowing it to follow the ceiling, i.e. utilize the Coanda effect. This enables the air to reach all the way to the perimeter wall. If Fan-shape air distribution is desirable, this is simply achieved by means of the ADC<sup>II</sup> (Anti Draft Control) feature, which is included as standard in all PARAGON comfort modules. If vertical air distribution is desirable, this is achieved by setting the louvers of the outlet grille to slant upward or downward. If you like, you can lock the angle setting of the outlet grille using an accessory that secures the louvers in fixed position.

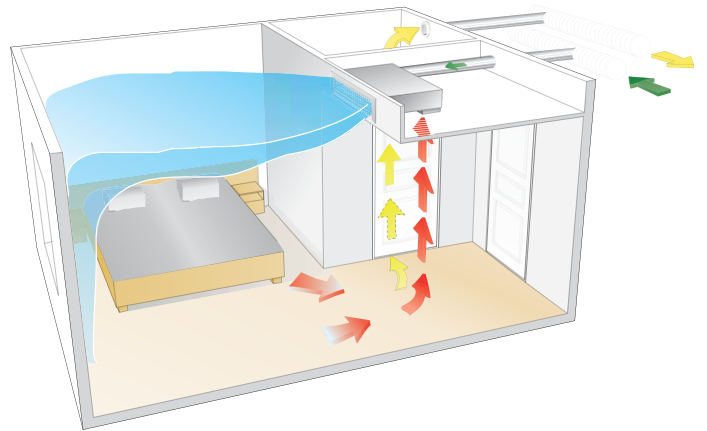

Figure 4. Air distribution with the PARAGON in a hotel room

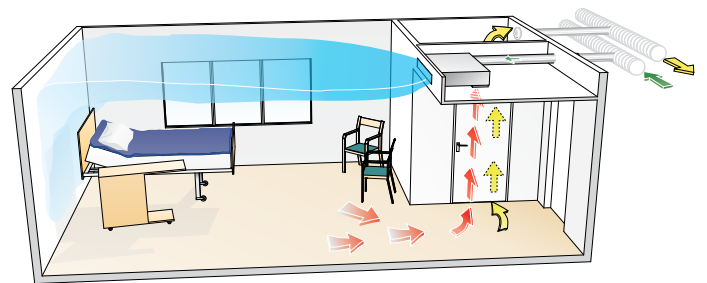

Figure 5. Air distribution with the PARAGON in a hospital patient room

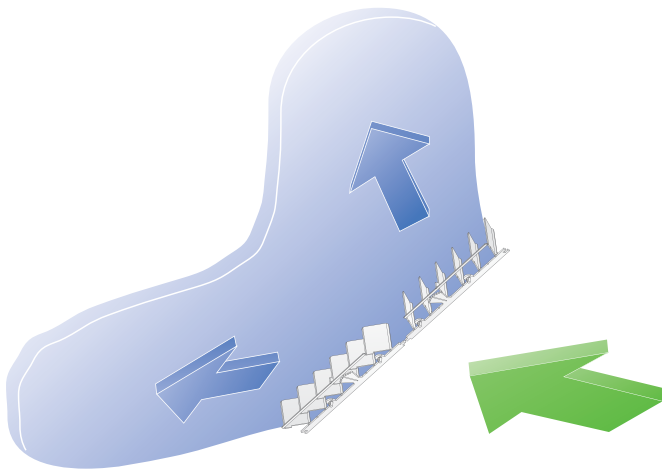

Figure 6. Fan shape air distribution with ADC<sup>II</sup>

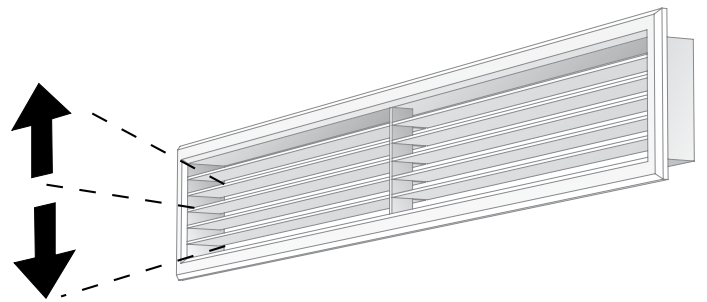

Figure 8. Vertical air distribution with adjustable louvers in the supply air grille.

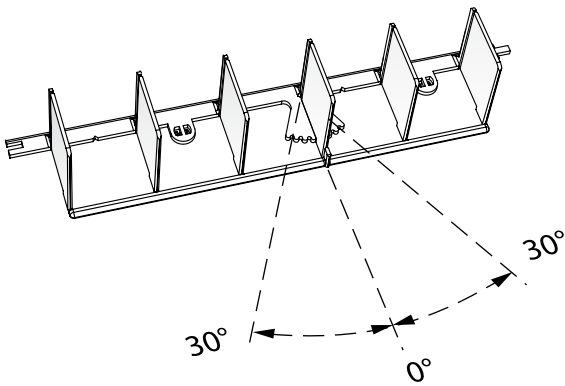

Figure 7. PARAGON ADC<sup>II</sup>



Figure 9. Adjustment, nozzle L

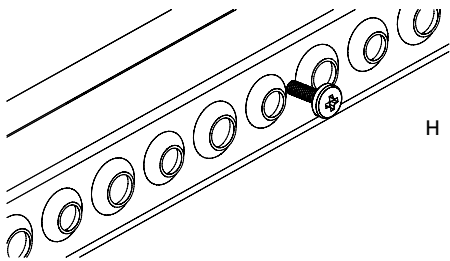
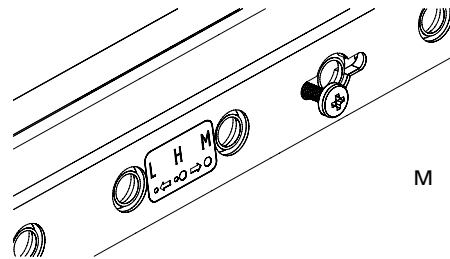
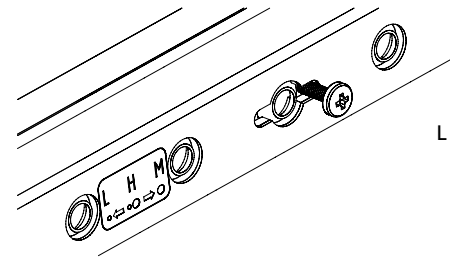

Figure 12. Adjustment of the nozzles L, M and H (the throttling strip by nozzle H has been removed).



Figure 10. Adjustment, nozzle, M



Figure 11. Adjustment, nozzle H

PARAGON b

## Planning

Both planning and sizing are made easier by using Swegon's ProSelect Project design computer program. ProSelect is available at Swegon's home page: [www.swegon.com](http://www.swegon.com).



## Sizing

### Designations

P: Capacity (Btuh)

v: Velocity (fpm)

q: Airflow (cfm)

p: Air pressure, (inWG)

$t_r$ : Room temperature (°F)

$t_m$ : Mean water temperature (°F)

$\Delta T$ : Temperature difference [ $t_r - t_m$ ] (°F)

$\Delta T_m$ : Temperature difference, between inlet and return (°F)

$\Delta T_r$ : Temperature difference, between room and supply air (°F)

$\Delta p$ : Water pressure drop (ftWG)

$k_p$ : Pressure drop constant

Supplementary index:  $k$  = cooling,  $l$  = air,  $v$  = heating,  $i$  = commissioning

### Recommended limit values, water

Max. recommended operating pressure (above coil only): 230 psi

Max. recommended test pressure (across coil only): 350 psi

Max. recommended pressure drop across standard valve: 6.7 ftWG

Min. permissible hot water flow: 0.2 gpm

Max. permissible inlet flow temperature: 140 °F

Min. permissible cooling water flow: 0.48 gpm

Lowest permissible inlet flow temperature: Should always be dimensioned so that the system works without condensation



# Cooling

## Cooling capacity

Cooling capacities achieved from both the primary air and chilled water for various lengths of unit, damper settings and airflows are tabulated in **Tables 3-10**. The total cooling capacity for one unit is the sum of the cooling capacity of the primary air and the chilled water.

Below are some formula that enable the user to calculate which comfort module selection is applicable:

### Cooling capacity of the air

$$P_i = 1.07384 \cdot q_i \cdot \Delta T_i$$

$P_i$  Cooling capacity of the primary air (Btuh)

$q_i$  Flow of primary air (cfm)

$\Delta T_i$  Temperature difference between primary air ( $t_i$ ) and room air ( $t_r$ ) (°F)

### Water's cooling capacity

$$P_k = 500 \cdot q_k \cdot \Delta T_k$$

$P_k$  Cooling capacity of the water (Btuh)

$q_k$  Cooling water flow (gpm)

$\Delta T_k$  Temperature difference of cooling water supply and return (°F)

### Pressure drop

The pressure drop on the water side can be calculated using the formula:

$$\Delta p = (q / k_{pk})^2$$

$\Delta p$  Pressure drop in the water circuit (ftWG)

$q$  Water flow (gpm), see **Diagram 1**

$k_{pk}$  Pressure drop constant read from **Table 1**

**Table 1. Pressure drop**

Pressure drop, water		
NC	Length (in.)	$k_{pk}$ Cooling
	35	0.5947
	43	0.5536
	51	0.5207
	59	0.4933
HC	Length (in.)	$k_{pk}$ Cooling
	35	0.5097
	43	0.4768
	51	0.4494
	59	0.4248

**Table 2. Cooling Capacity for Natural Convection**

Natural convection: The cooling capacity of water (Btuh) for $\Delta T_{mk}$ (°F)						
Size	10	12	14	16	18	20
35	59	74	87	101	113	127
43	79	94	112	128	147	162
51	93	116	136	158	177	200
59	114	136	162	186	212	235

### Diagram 1 – Cooling capacity

The function between cooling capacity  $P_k$  (Btuh), change in temperature  $\Delta T_k$  (°F) and cooling water flow  $q_k$  (gpm).

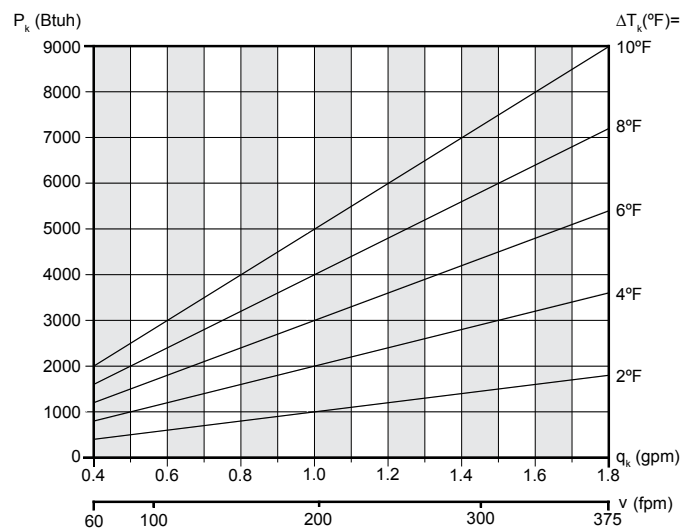

### Capacity correction

Different water flows influence the available cooling effect to a certain degree. To calculate the actual cooling power based on a flow-dependant correction factor, use Swegon's ProSelect computer program, available at [www.swegon.com](http://www.swegon.com).

**Diagram 2. Water flow – capacity correction**

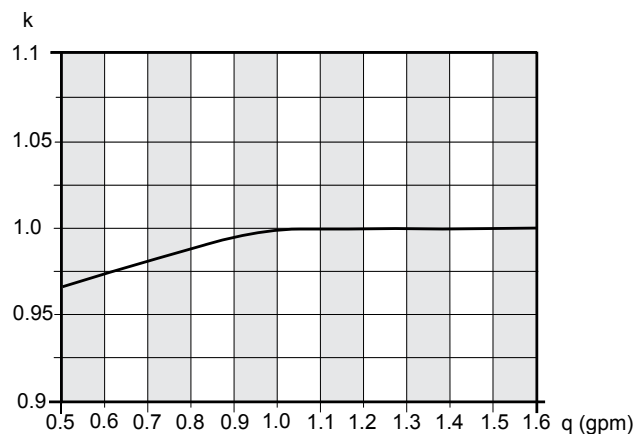

**Table 3 – Cooling capacity, NC, 0.28 inWG**

Length of the unit	Nozzle settings		Air-flow	Noise level <sup>1)</sup>	Nozzle pressure p <sub>i</sub>	Cooling capacity, primary air (Btuh) ΔT <sub>i</sub> (°F)				Cooling capacity of water (Btuh) for ΔT <sub>mk</sub> <sup>2)</sup> (°F)					Pressure drop constant, air	
						10	14	18	22	10	12	14	16	18		20
35	L	L	26	<20	0.28	285	398	512	626	766	917	1066	1217	1369	1520	50.20
35	M	M	34	<20	0.28	360	504	648	791	837	1005	1172	1338	1502	1668	63.26
35	H	H	58	<20	0.28	617	864	1111	1358	1012	1205	1395	1585	1778	1968	108.44
43	L	L	34	<20	0.28	370	519	667	815	979	1176	1371	1565	1758	1951	64.93
43	M	M	43	<20	0.28	462	646	831	1016	1080	1297	1511	1723	1939	2151	81.66
43	H	H	74	<20	0.28	800	1120	1440	1760	1306	1556	1804	2050	2297	2543	140.24
51	L	L	41	<20	0.28	440	616	792	969	1204	1443	1682	1921	2160	2396	77.65
51	M	M	52	<20	0.28	553	774	995	1217	1328	1590	1852	2114	2375	2637	97.73
51	H	H	89	<20	0.28	956	1338	1720	2103	1603	1906	2209	2513	2816	3115	167.34
59	L	L	35	<20	0.28	376	526	677	827	1267	1529	1793	2062	2328	2597	65.93
59	M	M	60	<20	0.28	639	895	1150	1406	1543	1858	2175	2491	2809	3128	112.12
59	H	H	91	21	0.28	977	1368	1759	2150	1855	2210	2567	2923	3276	3629	171.36

**Table 4 – Cooling capacity, NC, 0.40 inWG**

Length of the unit	Nozzle settings		Air-flow	Noise level <sup>1)</sup>	Nozzle pressure p <sub>i</sub>	Cooling capacity, primary air (Btuh) ΔT <sub>i</sub> (°F)				Cooling capacity of water (Btuh) for ΔT <sub>mk</sub> <sup>2)</sup> (°F)					Pressure drop constant, air	
						10	14	18	22	10	12	14	16	18		20
35	L	L	32	<20	0.40	344	481	619	756	896	1071	1245	1420	1590	1764	50.20
35	M	M	40	<20	0.40	430	601	773	945	985	1175	1365	1554	1744	1934	63.26
35	H	H	68	20	0.40	736	1030	1324	1618	1167	1390	1614	1835	2055	2275	108.44
43	L	L	41	<20	0.40	440	616	792	969	1159	1384	1607	1831	2055	2278	64.93
43	M	M	52	20	0.40	553	774	995	1217	1271	1516	1763	2007	2249	2492	81.66
43	H	H	89	22	0.40	956	1338	1720	2103	1505	1794	2082	2368	2655	2936	140.24
51	L	L	49	<20	0.40	526	737	947	1158	1418	1695	1972	2246	2519	2792	77.65
51	M	M	62	21	0.40	666	932	1198	1465	1558	1861	2162	2461	2761	3057	97.73
51	H	H	106	23	0.40	1138	1594	2049	2504	1840	2197	2551	2900	3249	3598	167.34
59	L	L	42	21	0.40	446	624	802	980	1500	1803	2109	2414	2720	3024	65.93
59	M	M	71	22	0.40	762	1067	1372	1677	1808	2168	2531	2892	3256	3616	112.12
59	H	H	108	26	0.40	1165	1631	2097	2563	2123	2532	2944	3352	3761	4167	171.36

<sup>1)</sup> The specified noise level is applicable to connection without damper or with fully open damper. In other cases where the airflow is demand-controlled with motor-driven dampers, the required data can be read from Swegon’s ProSelect sizing program. Room attenuation = 10 dB

<sup>2)</sup> The specified capacities are based on a complete unit including standard distribution and recirculation grille. Without grille the water capacity increases by approx. 5%. With ADC<sup>II</sup> adjusted to Fan shape you lose approx. 5% in water capacity. The primary air capacity is not affected.

**NOTE!** 1. The total cooling capacity is the sum of the air-based and water-based cooling capacities.

2. NC = Normal Capacity version



**Table 5 – Cooling capacity, NC, 0.60 inWG**

Length of the unit	Nozzle settings		Air-flow	Noise level <sup>1)</sup>	Nozzle pressure P <sub>i</sub>	Cooling capacity, primary air (Btuh) ΔT <sub>i</sub> (°F)				Cooling capacity of water (Btuh) for ΔT <sub>mk</sub> <sup>2)</sup> (°F)						Pressure drop constant, air k <sub>pl</sub>
						10	14	18	22	10	12	14	16	18	20	
35	L	L	39	<20	0.60	419	586	754	921	1053	1254	1455	1652	1850	2051	50.20
35	M	M	49	25	0.60	526	737	947	1158	1151	1371	1591	1807	2020	2236	63.26
35	H	H	84	26	0.60	902	1263	1624	1984	1344	1602	1859	2117	2372	2626	108.44
43	L	L	50	<20	0.60	542	759	976	1193	1357	1618	1876	2134	2389	2646	64.93
43	M	M	64	26	0.60	682	955	1227	1500	1485	1766	2046	2327	2604	2880	81.66
43	H	H	108	27	0.60	1165	1631	2097	2563	1734	2067	2398	2732	3061	3391	140.24
51	L	L	60	20	0.60	644	902	1160	1417	1660	1979	2298	2614	2928	3239	77.65
51	M	M	76	27	0.60	811	1135	1459	1784	1818	2163	2508	2850	3191	3529	97.73
51	M	H	103	28	0.60	1106	1548	1991	2433	2009	2396	2780	3163	3546	3925	132.54
59	L	L	51	25	0.60	548	767	986	1205	1768	2117	2466	2815	3164	3509	65.93
59	M	M	87	28	0.60	934	1308	1682	2055	2113	2530	2944	3358	3771	4184	112.12
59	M	H	110	29	0.60	1181	1654	2126	2599	2305	2756	3204	3655	4102	4547	141.91

**Table 6 – Cooling capacity, NC, 0.80 inWG**

Length of the unit	Nozzle settings		Air-flow	Noise level <sup>1)</sup>	Nozzle pressure P <sub>i</sub>	Cooling capacity, primary air (Btuh) ΔT <sub>i</sub> (°F)				Cooling capacity of water (Btuh) for ΔT <sub>mk</sub> <sup>2)</sup> (°F)						Pressure drop constant, air k <sub>pl</sub>
						10	14	18	22	10	12	14	16	18	20	
35	L	L	45	23	0.80	483	677	870	1063	1158	1378	1598	1814	2031	2247	50.20
35	M	M	56	29	0.80	607	849	1092	1335	1266	1505	1741	1976	2212	2443	63.26
43	L	L	58	24	0.80	623	872	1121	1370	1495	1778	2062	2344	2621	2898	64.93
43	M	M	73	30	0.80	784	1097	1411	1725	1635	1942	2249	2554	2853	3153	81.66
51	L	L	70	25	0.80	746	1045	1343	1642	1838	2183	2531	2874	3218	3556	77.65
51	M	M	88	31	0.80	940	1315	1691	2067	2007	2382	2758	3130	3502	3870	97.73
59	L	L	59	29	0.80	634	887	1140	1394	1964	2343	2725	3105	3485	3864	65.93
59	M	M	100	32	0.80	1079	1511	1943	2374	2327	2782	3234	3685	4133	4581	112.12

<sup>1)</sup> The specified noise level is applicable to connection without damper or with fully open damper. In other cases where the airflow is demand-controlled with motor-driven dampers, the required data can be read from Swegon’s ProSelect sizing program. Room attenuation = 10 dB

<sup>2)</sup> The specified capacities are based on a complete unit including standard distribution and recirculation grille. Without grille the water capacity increases by approx. 5%. With ADC<sup>II</sup> adjusted to Fan shape you lose approx. 5% in water capacity. The primary air capacity is not affected.

**NOTE!** 1. The total cooling capacity is the sum of the air-based and water-based cooling capacities.  
2. NC = Normal Capacity version

**Table 7 – Cooling capacity, HC, 0.28 inWG**

Length of the unit	Nozzle settings		Air-flow	Noise level <sup>1)</sup>	Nozzle pressure p <sub>i</sub>	Cooling capacity, primary air (Btuh) ΔT <sub>i</sub> (°F)				Cooling capacity of water (Btuh) for ΔT <sub>mk</sub> <sup>2)</sup> (°F)						Pressure drop constant, air k <sub>pl</sub>
						10	14	18	22	10	12	14	16	18	20	
35	L	L	26	<20	0.28	285	398	512	626	774	929	1083	1237	1389	1544	50.20
35	M	M	34	<20	0.28	360	504	648	791	875	1050	1222	1396	1567	1741	63.26
35	H	H	58	<20	0.28	617	864	1111	1358	1089	1294	1501	1707	1911	2112	108.44
43	L	L	34	<20	0.28	370	519	667	815	1006	1204	1401	1601	1799	1996	64.93
43	M	M	43	<20	0.28	462	646	831	1016	1128	1353	1576	1797	2020	2244	81.66
43	H	H	74	<20	0.28	800	1120	1440	1760	1404	1673	1940	2205	2471	2733	140.24
51	L	L	41	<20	0.28	440	616	792	969	1232	1479	1723	1968	2212	2454	77.65
51	M	M	52	<20	0.28	553	774	995	1217	1384	1661	1935	2209	2481	2754	97.73
51	H	H	88	<20	0.28	950	1330	1711	2091	1720	2045	2372	2697	3020	3343	167.34
59	L	L	35	<20	0.28	376	526	677	827	1295	1564	1836	2110	2382	2659	65.93
59	M	M	60	<20	0.28	639	895	1150	1406	1620	1912	2226	2551	2881	3207	112.12
59	H	H	90	21	0.28	972	1361	1749	2138	1985	2372	2756	3136	3515	3895	171.36

**Table 8 – Cooling capacity, HC, 0.40 inWG**

Length of the unit	Nozzle settings		Air-flow	Noise level <sup>1)</sup>	Nozzle pressure p <sub>i</sub>	Cooling capacity, primary air (Btuh) ΔT <sub>i</sub> (°F)				Cooling capacity of water (Btuh) for ΔT <sub>mk</sub> <sup>2)</sup> (°F)						Pressure drop constant, air k <sub>pl</sub>
						10	14	18	22	10	12	14	16	18	20	
35	L	L	32	<20	0.40	344	481	619	756	942	1123	1305	1487	1669	1851	50.20
35	M	M	40	<20	0.40	430	601	773	945	1057	1257	1461	1663	1867	2068	63.26
35	H	H	68	20	0.40	736	1030	1324	1618	1280	1527	1774	2017	2259	2502	108.44
43	L	L	41	<20	0.40	440	616	792	969	1217	1452	1687	1925	2154	2388	64.93
43	M	M	52	20	0.40	553	774	995	1217	1359	1621	1883	2145	2406	2664	81.66
43	H	H	89	22	0.40	956	1338	1720	2103	1655	1973	2289	2604	2918	3229	140.24
51	L	L	49	<20	0.40	526	737	947	1158	1493	1781	2068	2357	2645	2930	77.65
51	M	M	62	21	0.40	666	932	1198	1465	1670	1992	2311	2634	2952	3271	97.73
51	H	H	106	23	0.40	1138	1594	2049	2504	2025	2415	2803	3190	3573	3956	167.34
59	L	L	42	21	0.40	446	624	802	980	1575	1894	2212	2531	2853	3172	65.93
59	M	M	71	22	0.40	762	1067	1372	1677	1950	2288	2654	3037	3420	3799	112.12
59	H	H	108	26	0.40	1165	1631	2097	2563	2330	2785	3238	3685	4137	4581	171.36

<sup>1)</sup> The specified noise level is applicable to connection without damper or with fully open damper. In other cases where the airflow is demand-controlled with motor-driven dampers, the required data can be read from Swegon’s ProSelect sizing program. Room attenuation = 10 dB

<sup>2)</sup> The specified capacities are based on a complete unit including standard distribution and recirculation grille. Without grille the water capacity increases by approx. 5%. With ADC<sup>II</sup> adjusted to Fan shape you lose approx. 5% in water capacity. The primary air capacity is not affected.

**NOTE!** 1. The total cooling capacity is the sum of the air-based and water-based cooling capacities.  
 2. HC = High Capacity version

**Table 9 – Cooling capacity, HC, 0.60 inWG**

Length of the unit	Nozzle settings		Air-flow	Noise level <sup>1)</sup>	Nozzle pressure p <sub>i</sub>	Cooling capacity, primary air (Btuh) ΔT <sub>i</sub> (°F)				Cooling capacity of water (Btuh) for ΔT <sub>mk</sub> <sup>2)</sup> (°F)					Pressure drop constant, air k <sub>pl</sub>	
						10	14	18	22	10	12	14	16	18		20
35	L	L	39	<20	0.60	419	586	754	921	1126	1341	1555	1770	1983	2195	50.20
35	M	M	49	25	0.60	526	737	947	1158	1252	1491	1728	1966	2198	2433	63.26
35	H	H	84	26	0.60	902	1263	1624	1984	1505	1794	2082	2370	2659	2943	108.44
43	L	L	50	<20	0.60	542	759	976	1193	1456	1733	2010	2286	2560	2832	64.93
43	M	M	64	26	0.60	682	955	1227	1500	1617	1927	2233	2539	2840	3143	81.66
43	H	H	108	27	0.60	1165	1631	2097	2563	1939	2314	2687	3059	3430	3798	140.24
51	L	L	60	20	0.60	644	902	1160	1417	1783	2121	2461	2799	3133	3466	77.65
51	M	M	76	27	0.60	816	1143	1469	1795	1990	2365	2741	3116	3488	3860	97.73
51	M	H	103	28	0.60	1106	1548	1991	2433	2232	2660	3088	3514	3935	4359	132.54
59	L	L	51	25	0.60	548	767	986	1205	1891	2266	2639	3013	3386	3757	65.93
59	M	M	87	27	0.60	934	1308	1682	2055	2281	2774	3238	3692	4154	4598	112.12
59	M	H	110	29	0.60	1181	1654	2126	2599	2548	3063	3569	4066	4570	5060	141.91

**Table 10 – Cooling capacity, HC, 0.80 inWG**

Length of the unit	Nozzle settings		Air-flow	Noise level <sup>1)</sup>	Nozzle pressure p <sub>i</sub>	Cooling capacity, primary air (Btuh) ΔT <sub>i</sub> (°F)				Cooling capacity of water (Btuh) for ΔT <sub>mk</sub> <sup>2)</sup> (°F)					Pressure drop constant, air k <sub>pl</sub>	
						10	14	18	22	10	12	14	16	18		20
35	L	L	45	23	0.80	483	677	870	1063	1252	1491	1730	1966	2198	2433	50.20
35	M	M	56	29	0.80	607	849	1092	1335	1396	1661	1921	2182	2440	2697	63.26
43	L	L	58	24	0.80	623	872	1121	1370	1618	1925	2232	2537	2836	3139	64.93
43	M	M	73	30	0.80	784	1097	1411	1725	1804	2141	2478	2816	3147	3480	81.66
51	L	L	70	25	0.80	746	1045	1343	1642	1985	2364	2738	3112	3481	3853	77.65
51	M	M	88	31	0.80	940	1315	1691	2067	2212	2629	3043	3454	3864	4270	97.73
59	L	L	59	29	0.80	634	887	1140	1394	2125	2538	2951	3362	3771	4181	65.93
59	M	M	100	32	0.80	1079	1511	1943	2374	2485	3167	3733	4248	4775	5269	112.12

<sup>1)</sup> The specified noise level is applicable to connection without damper or with fully open damper. In other cases where the airflow is demand-controlled with motor-driven dampers, the required data can be read from Swegon’s ProSelect sizing program. Room attenuation = 10 dB

<sup>2)</sup> The specified capacities are based on a complete unit including standard distribution and recirculation grille. Without grille the water capacity increases by approx. 5%. With ADC<sup>II</sup> adjusted to Fan shape you lose approx. 5% in water capacity. The primary air capacity is not affected.

**NOTE!** 1. The total cooling capacity is the sum of the air-based and water-based cooling capacities.  
 2. HC = High Capacity version

PARAGON b

# Heating

## Heating capacity

Heating capacities are tabulated in **Tables 13-16**.

The heating capacity of the water can be calculated using the formula:

### Water's heating capacity

$$P_v = 500 \cdot q_v \cdot \Delta T_v \text{ where}$$

$P_v$  Heating capacity of the water (Btuh)

$q_v$  Flow of heating water (gpm)

$\Delta T_v$  Temperature difference between the heating water's flow and return flow (°F)

## Pressure drop

The pressure drop on the water side can be calculated using the formula:

$$\Delta p_v = (q_v / k_{pv})^2 \text{ where}$$

$\Delta p_v$  Pressure drop in heating circuit (ftWG)

$q_v$  Flow of heating water (gpm), see **Diagram 3**

$k_{pv}$  Pressure drop constant for heating circuit, see **Table 11**

For a more detailed pressure drop calculation, use the Swegon ProSelect computer program available at [www.swegon.com](http://www.swegon.com).

**Table 11. Pressure drop**

Pressure drop, water		
NC	Length (in.)	$k_{pv}$ Heating
	35	0.4878
	43	0.4549
	51	0.4275
HC	Length (in.)	$k_{pv}$ Heating
	35	0.4878
	43	0.4549
	51	0.4275
	59	0.4056

**Table 12 - Heating capacity for natural convection**

Length (in.)	Heat emission when $\Delta T_{mv}$ [°F] (Btuh)						
	9	18	27	36	45	54	63
35	7	24	48	82	119	167	218
43	10	31	61	106	157	215	283
51	10	38	75	126	191	263	348
59	14	44	89	150	225	314	413

**Diagram 3 - Heating capacity**

The function between heating capacity  $P_v$  (Btuh), change in temperature  $\Delta T_v$  (°F) and heating water flow,  $q_v$  (gpm).

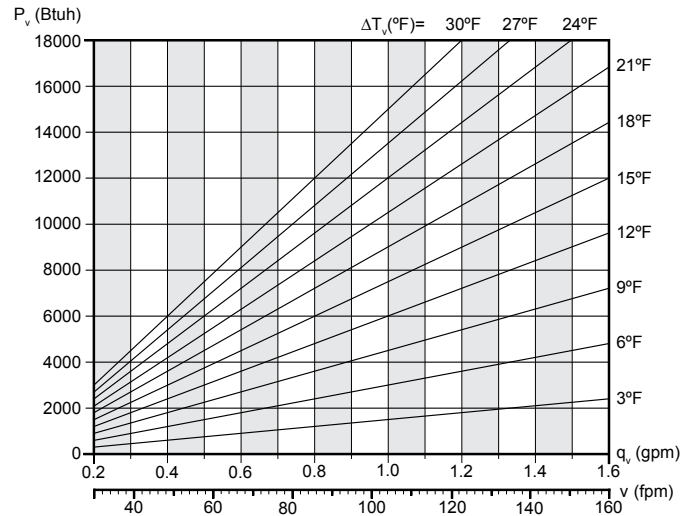

**Table 13 – Heating capacity, NC <sup>2)</sup>/HC <sup>3)</sup>, 0.28 inWG**

Length of the unit	Nozzle settings		Airflow	Noise level <sup>1)</sup>	Nozzle pressure p <sub>i</sub>	Heating capacity, water (Btuh) for ΔT <sub>mv</sub> (°F)						Pressure drop constant, air
						10	20	30	40	50	60	
in.			cfm	dB(A)	inWG							k <sub>pl</sub>
35	L	L	26	<20	0.28	436	873	1314	1759	2205	2651	50.20
35	M	M	34	<20	0.28	558	1114	1668	2221	2775	3329	63.26
35	H	H	58	<20	0.28	588	1182	1806	2434	3069	3711	108.44
43	L	L	34	<20	0.28	562	1128	1701	2275	2851	3430	64.93
43	M	M	43	<20	0.28	717	1436	2150	2865	3579	4291	81.66
43	H	H	74	<20	0.28	759	1530	2333	3145	3968	4798	140.24
51	L	L	41	<20	0.28	690	1386	2089	2794	3501	4213	77.65
51	M	M	52	<20	0.28	880	1762	2638	3513	4387	5263	97.73
51	H	H	88	<20	0.28	929	1869	2855	3846	4851	5865	167.34
59	L	L	35	<20	0.28	819	1640	2471	3305	4143	4983	65.93
59	M	M	60	<20	0.28	1043	2081	3116	4151	5187	6220	112.12
59	H	H	90	21	0.28	1100	2213	3376	4551	5742	6942	171.36

**Table 14 – Heating capacity, NC <sup>2)</sup>/HC <sup>3)</sup>, 0.40 inWG**

Length of the unit	Nozzle settings		Airflow	Noise level <sup>1)</sup>	Nozzle pressure p <sub>i</sub>	Heating capacity, water (Btuh) for ΔT <sub>mv</sub> (°F)						Pressure drop constant, air
						10	20	30	40	50	60	
in.			cfm	dB(A)	inWG							k <sub>pl</sub>
35	L	L	32	<20	0.40	512	1020	1532	2044	2556	3071	50.20
35	M	M	40	<20	0.40	633	1264	1885	2503	3119	3734	63.26
35	H	H	68	20	0.40	645	1298	1985	2681	3387	4099	108.44
43	L	L	41	<20	0.40	659	1317	1980	2639	3301	3965	64.93
43	M	M	52	20	0.40	816	1631	2431	3228	4023	4817	81.66
43	H	H	89	22	0.40	830	1673	2563	3460	4370	5289	140.24
51	L	L	49	14	0.40	808	1616	2427	3237	4051	4862	77.65
51	M	M	62	21	0.40	1001	1999	2981	3960	4934	5909	97.73
51	H	H	106	23	0.40	1017	2050	3138	4236	5353	6479	167.34
59	L	L	42	21	0.40	955	1909	2867	3824	4784	5745	65.93
59	M	M	71	22	0.40	1183	2362	3522	4680	5832	6983	112.12
59	H	H	108	26	0.40	1206	2428	3713	5013	6334	7667	171.36

**NOTES**

<sup>1)</sup> The specified noise level is applicable to connection without damper or with fully open damper. In other cases where the airflow is demand-controlled with motor-driven dampers, the required data can be read from Swegon’s ProSelect sizing program. Room attenuation = 10 dB

<sup>2)</sup> NC = Normal Capacity version

<sup>3)</sup> HC = High Capacity version

**Table 15 – Heating capacity, NC <sup>2)</sup>/HC <sup>3)</sup>, 0.60 inWG**

Length of the unit	Nozzle settings		Airflow	Noise level <sup>1)</sup>	Nozzle pressure p <sub>i</sub>	Heating capacity, water (Btuh) for ΔT <sub>mv</sub> (°F)						Pressure drop constant, air
						in.						
			cfm	dB(A)	inWG	10	20	30	40	50	60	
35	L	L	39	<20	0.60	595	1186	1777	2365	2953	3541	50.20
35	M	M	49	25	0.60	717	1433	2127	2821	3507	4191	63.26
35	H	H	84	26	0.60	709	1425	2188	2959	3744	4538	108.44
43	L	L	50	<20	0.60	766	1531	2294	3054	3812	4571	64.93
43	M	M	64	26	0.60	929	1849	2748	3642	4529	5414	81.66
43	H	H	108	27	0.60	914	1841	2824	3818	4831	5855	140.24
51	L	L	60	20	0.60	940	1876	2809	3741	4669	5596	77.65
51	M	M	76	27	0.60	1138	2269	3371	4466	5556	6642	97.73
51	M	H	103	28	0.60	1127	2260	3425	4599	5783	6973	132.54
59	L	L	51	25	0.60	1108	2217	3316	4416	5514	6610	65.93
59	M	M	87	27	0.60	1343	2680	3980	5275	6561	7842	112.12
59	M	H	110	29	0.60	1331	2674	4051	5435	6831	8236	141.91

**Table 16 – Heating capacity, NC <sup>2)</sup>/HC <sup>3)</sup>, 0.80 inWG**

Length of the unit	Nozzle settings		Airflow	Noise level <sup>1)</sup>	Nozzle pressure p <sub>i</sub>	Heating capacity, water (Btuh) for ΔT <sub>mv</sub> (°F)						Pressure drop constant, air
						in.						
			cfm	dB(A)	inWG	10	20	30	40	50	60	
35	L	L	45	23	0.80	652	1302	1944	2587	3229	3867	50.20
35	M	M	56	29	0.80	781	1553	2303	3047	3786	4521	63.26
43	L	L	58	24	0.80	842	1681	2511	2159	2986	4989	64.93
43	M	M	73	30	0.80	1005	2006	2972	3932	4886	5833	81.66
51	L	L	70	25	0.80	1031	2061	3080	4096	5110	6120	77.65
51	M	M	88	31	0.80	1236	2459	3645	4822	5992	7155	97.73
59	L	L	59	29	0.80	1221	2439	3644	4845	6043	7239	65.93
59	M	M	100	32	0.80	1460	2908	4308	5702	7085	8459	112.12

**NOTES**

<sup>1)</sup> The specified noise level is applicable to connection without damper or with fully open damper. In other cases where the airflow is demand-controlled with motor-driven dampers, the required data can be read from Swegon’s ProSelect sizing program. Room attenuation = 10 dB

<sup>2)</sup> NC = Normal Capacity version

<sup>3)</sup> HC = High Capacity version



## Example

### Cooling

#### Conditions

A hotel room having dimensions  $L \times W \times H = 12 \times 10 \times 9$  ft is to be ventilated, cooled and heated by the PARAGON. The cooling demand is estimated to be 22 Btuh/sq.ft for an occupied room and normal load conditions.

In rare cases, the load conditions may be slightly higher and are then estimated to be 27 Btuh/sq.ft. The cooling demand is then a total of  $22 \times 12 \times 10 = 2640$  Btuh and  $27 \times 12 \times 10 = 3240$  Btuh respectively.

Under normal load conditions, the supply air flow should be 51 cfm and have a temperature of 59 °F. For higher load conditions, an increase in supply air flow up to a maximum of 63 cfm is permissible. The available duct pressure is kept constant at 0.65 inWG. The sound level must not exceed 25 dB(A) under normal circumstances and 30 dB(A) in the event of higher load conditions.

The design room temperature in the summer case is set to 75 °F. The inlet temperature of the cooling water is 57 °F and its outlet temperature on returning is 61 °F.

#### Solution

The 59 °F supply air temperature and the 75 °F room temperature provide  $\Delta T_1 = 16$  °F.

The temperature increase of the cooling water is  $61 - 57 = 4$  °F.

The mean temperature of the cooling water is:  
 $(57 + 61) / 2 = 59$  °F.

The 59 °F mean temperature of the cooling water and the 75 °F room temperature provide  $\Delta T_{mk} = 16$  °F.

#### Normal case

The cooling capacity of the supply air is calculated:  $P_1 = 1.07384 \times 51 \times 16 = 876$  Btuh.

The residual cooling capacity demanded by the cooling water is:

$$2640 - 876 = 1764 \text{ Btuh.}$$

In **Table 4**, we read that a PARAGON 43 with MM nozzle adjustment produces 2007 Btuh in cooling capacity for 51 cfm supply airflow, 0.40 inWG nozzle pressure and  $\Delta T_{mk} = 16$  °F. This is more than adequate to meet the cooling demand.

From **Diagram 1** we read 1764 Btuh capacity and an increase in cooling water temperature of 4 °F as well as a water flow of approx. 0.88 gpm. Using the water flow and pressure drop constant  $k_{pk}$  which is taken from **Table 1**. The pressure drop across the coil will then be:

$$\Delta P_k = (0.88 / 0.5536)^2 = 2.5 \text{ ftWG.}$$

Read from **Table 4**, the sound level is 20 dB(A), which meets the max. permissible level of 25 dB(A) required.

#### High load

Under high load conditions, a motorized damper is opened to set boost level by the control equipment. A supply airflow of 63 cfm is obtained, if the nozzle pressure is 0.60 inWG, which is in conformity with the demand on maximal 63 cfm.

Calculate the cooling capacity of the supply air:

$$P_1 = 1.07384 \times 60 \times 16 = 1031 \text{ Btuh.}$$

The residual cooling capacity demanded by the cooling water is:

$$2890 - 881 = 2009 \text{ Btuh.}$$

In **Table 5**, we read that a PARAGON 43 with MM nozzle adjustment produces 2327 Btuh in cooling capacity for 63 cfm supply airflow, 0.60 inWG nozzle pressure and  $\Delta T_{mk} = 16$  °F. This is adequate to meet the higher cooling load.

From **Diagram 1** we read 2209 Btuh capacity and an increase in cooling water temperature of 4 °F as well as a water flow of approx. 1.10 gpm. Using the water flow and pressure drop constant  $k_{pk}$  which is taken from **Table 1**.

The pressure drop across the coil will then be:

$$\Delta P_k = (1.10 / 0.5536)^2 = 3.95 \text{ ftWG.}$$

The sound level as specified in **Table 5** and is 26 dB(A), which is clearly lower than the requirement of maximal permissible 30 dB(A) under max load conditions.

However note that the sound levels in the tables do not include the sound generated from the damper.

## Heating

### Conditions

The prerequisites are the same as in the example for cooling, with the exception that the design room temperature in the winter case is 72 °F and the supply air temperature is 64 °F.

The heating load is estimated to be 14.7 Btuh/sq.ft for an occupied room and normal load conditions. In rare cases, the load conditions may be slightly higher and are then estimated to be 19.8 Btuh/sq.ft. The heating demand is then a total of  $14.7 \times 11.3 \times 10.7 = 1777$  Btuh and  $19.8 \times 11.3 \times 10.7 = 2394$  Btuh respectively.

The inlet temperature of the heating water is 122 °F and the return temperature is 111 °F.

### Solution

The 64 °F supply air temperature is lower than the 72 °C design room temperature and then has a negative effect on the heating capacity:

$$1.07384 \times 42 \times (72 - 64) = 361 \text{ Btuh.}$$

The heating demand for heating water then increases to  $1777 + 363 = 2140$  Btuh and  $2394 + 363 = 2757$  Btuh respectively.

The 117 °F mean temperature of the heating water and the 72 °F room temperature provide  $\Delta T_{mv} = 117 - 72 = 45$  °F.

In **Table 13**, we read that a PARAGON 43 with MM nozzle adjustment produces 3222 Btuh in heating capacity for 43.2 cfm supply airflow, 0.28 inWG nozzle pressure and  $\Delta T_{mv} = 45$  K.

This is enough to manage the heating demand when normal load (2096 Btuh). From **Table 14**, we read 48 Btuh for a supply airflow of 51.7 cfm, which meets the demand under high load conditions (2713 Btuh).

From **Diagram 3** we read a capacity of 3222 Btuh and a 11 °F decrease in heating water temperature as well as a water flow of approx. 0.602 gpm.

By means of the water flow and the pressure drop constant  $k_{pv}$  which is taken from **Table 11**. The pressure drop can be calculated across the coil:

$$\Delta p_v = (0.602 / 0.4549)^2 = 1.75 \text{ ftWG.}$$

The same calculation for the heating capacity during high load provides the pressure drop  $\Delta p_v = (0.666 / 0.4549)^2 = 2.14$  ftWG.

### ProSelect

Planning and sizing based on given design considerations can also be carried out in Swegon’s ProSelect project design program.

ProSelect is available at Swegon’s home page: [www.swegon.com](http://www.swegon.com).

## Acoustics

### Natural attenuation

Natural attenuation is the total reduction in sound power from duct to room including the end reflection of the unit.

**Table 17. Natural attenuation with lining**

Natural attenuation (dB) for mid frequency f (Hz) $\Delta L_w$ [dB]							
63	125	250	500	1k	2k	4k	8k
24	14	9	6	9	14	14	18

## Accessories

### Supply air kit – PARAGON T-SAK-VAV

A motor-driven damper is needed in applications where the user wants to apply demand control to the supply air by means of CONDUCTOR control equipment. The damper causes a certain amount of flow-generated sound. Therefore a sound attenuator is also needed to guarantee a low sound level in the room.

As standard the connection has an OD of 5 in.. There is also a connection with an OD of 4 in. available, which is suitable when the space is limited.

The following components are included in PARAGON T-SAK-VAV:

- Motor-driven damper    CRTc including Belimo CM24
- Sound attenuator        CLA rectangular sound attenuator with circular connection spigots

Sound attenuator

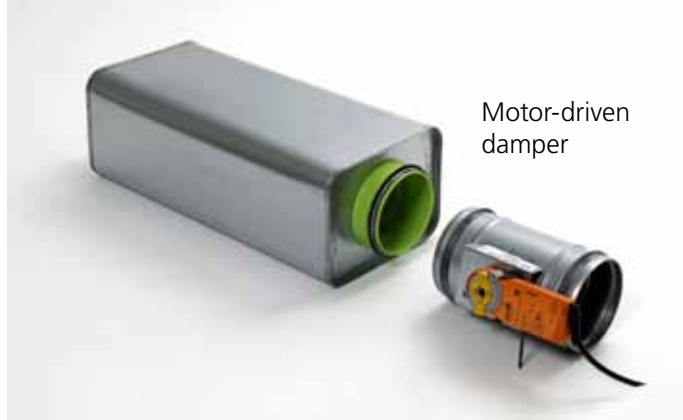

Figure 13. PARAGON T-SAK-VAV

### Supply air kit – PARAGON T-SAK-CAV

A commissioning damper is needed to ensure the correct airflow if a simpler regulation system with constant airflow has been selected. Commissioning dampers also generate a certain amount of sound. We therefore recommend the use of a sound attenuator for keeping the sound level at a minimum.

As standard the connection has an OD of 5 in.. There is also a connection with an OD of 4 in. available, which is suitable when the space is limited.

The following components are included in PARAGON T-SAK-CAV:

- Commissioning damper    CRPc-9 commissioning damper with perforated damper blade and manually adjustable blade.
- Sound attenuator        CLA rectangular sound attenuator with circular connection spigots

Sound attenuator



Figure 14. PARAGON T-SAK-CAV

**Extract air kit – PARAGON T-EAK-VAV**

If the supply air is demand-controlled, the extract air also needs to be feed-back controlled. An extract air kit is needed for balancing the supply air and the extract air. Precisely like the supply air kit, this kit consists of a motor-driven damper and a sound attenuator. In addition an extract air register and two alternative mounting frames are included: one with a nipple and one with a joint.

Motor-driven damper	CRTc including Belimo CM24
Sound attenuator	CLA rectangular sound attenuator with circular connection spigots
Extract air register	EXCa and accompanying mounting frames: one with circular connection spigot and one with circular connection sleeve.



Figure 15. Extract air kit, PARAGON T-EAK-VAV

**Extract air kit – PARAGON T-EAK-CAV**

A commissioning damper is needed in systems with constant airflows in order to balance the extract airflow with the supply airflow.

Therefore a kit designed for constant airflows is available for simpler systems. This kit contains commissioning damper, sound attenuator, extract air register and mounting frames.

Commissioning damper	CRPc-9 commissioning damper with perforated damper blade and manually adjustable blade.
Sound attenuator	CLA rectangular sound attenuator with circular connection spigots
Extract air register	EXCa and accompanying mounting frames: one with a nipple and one with a joint.



Figure 16. Extract air kit - PARAGON T-EAK-CAV

### Accessories – Supply air

The supply air grille is supplied with a 1.77" spigot / frame as standard however it can be combined with an extra spigot for use as an extension in increments of 1.77" mm.

A grille with a telescopic spigot that covers an interval of 3.94" - 5.51" between the module and wall is available as an optional extra. Cannot be combined with the standard frame stated above.

#### PARAGON b T-SG

Supply air grille incl. 1.77" spigot

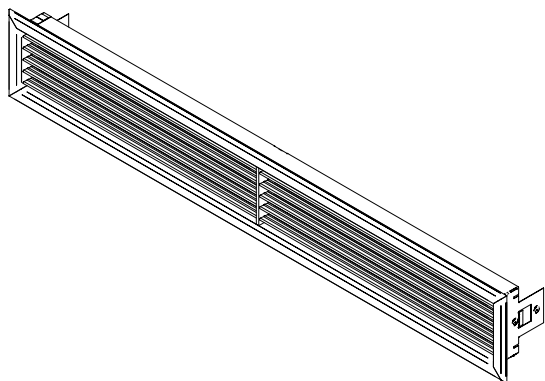

#### PARAGON b T-OE-SG

Extra 1.77" spigot for the supply air grille

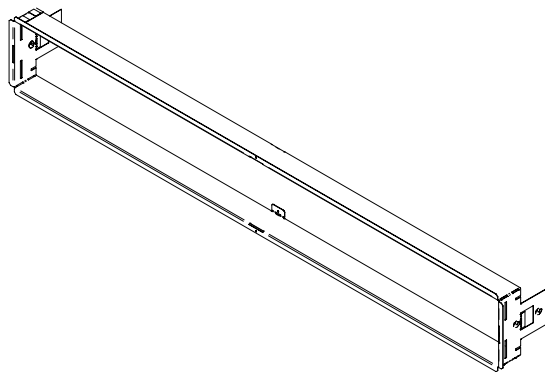

#### PARAGON b T-TE-SG

Telescopic spigot for the supply air grille, 3.94"-5.51"

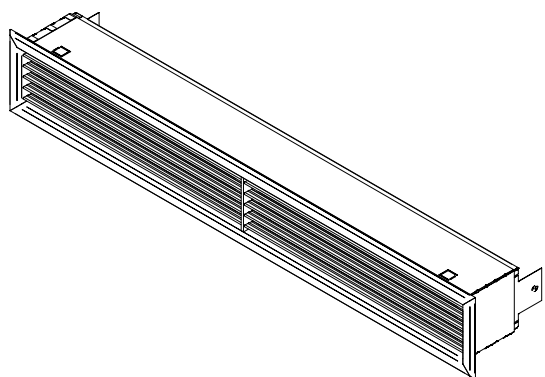

### Accessories - Return air

The return air grille is supplied with a 1.38" spigot/frame which can be inserted into the module and which then covers the .51"-1.38" interval between the module and the ceiling.

An extra spigot for the return air grille can be ordered as an accessory and then covers the 1.38"-2.76" interval installed together with the standard spigot.

#### PARAGON b T-RG

Return air grille incl. .51"-1.38" spigot

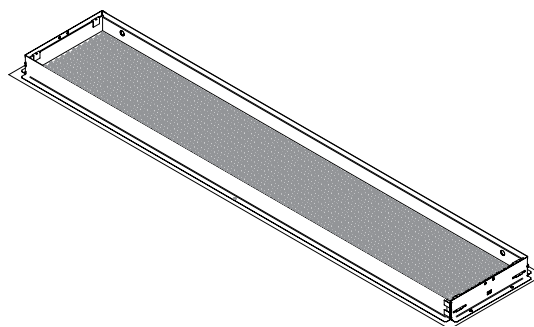

#### PARAGON b T-OE-RG

Extra 1.38"-2.76" spigot for the return air grille

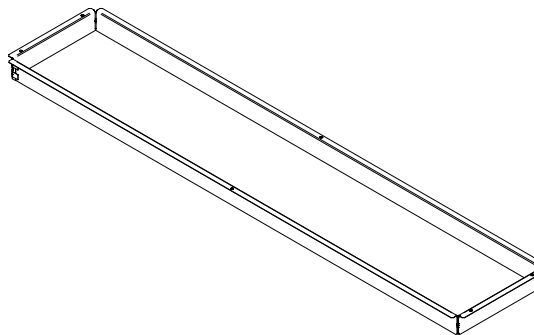

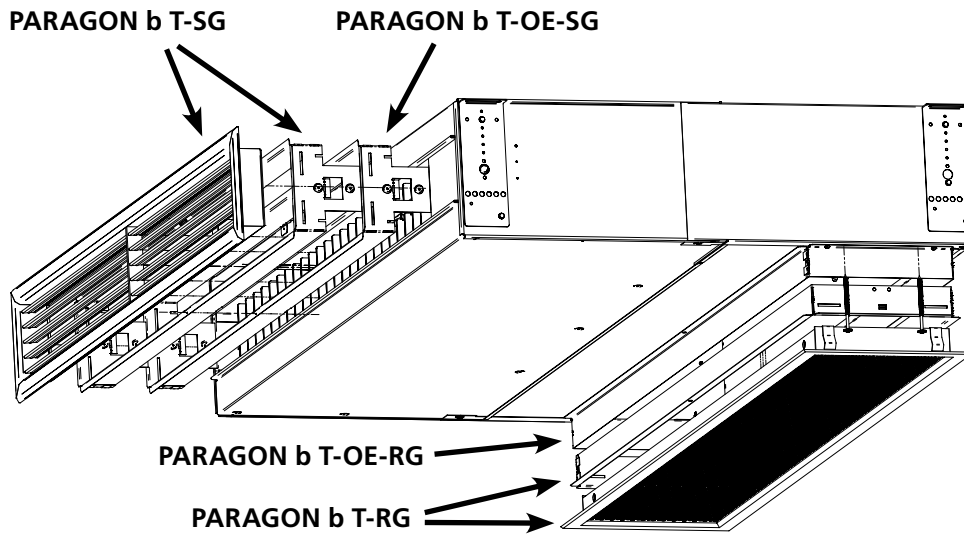

Accessories - Supply air

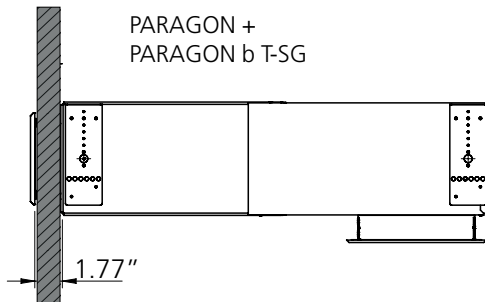

Accessories - Extract air

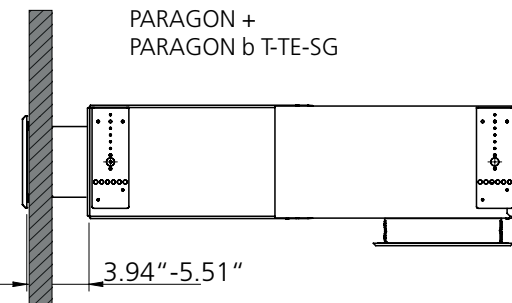
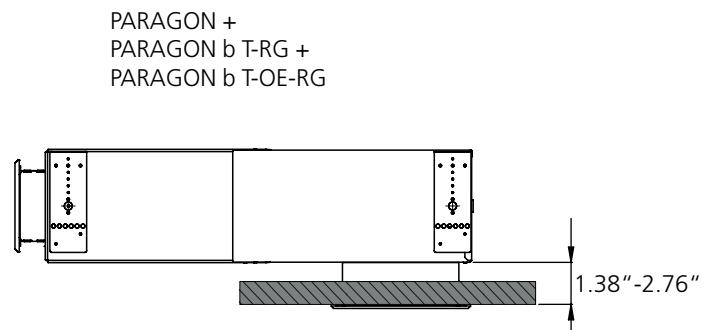
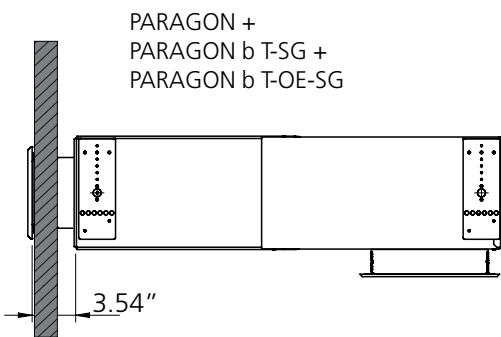
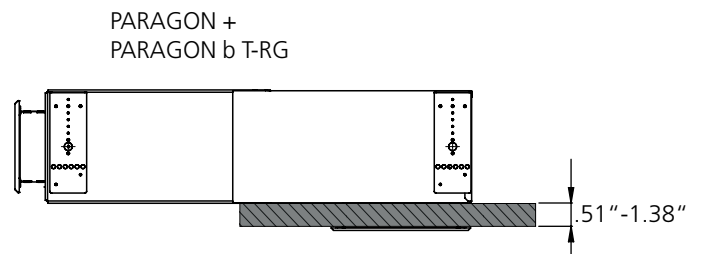



### SYST MS M8 suspension kit

In the applications in which the PARAGON is not mounted in direct contact with the ceiling, there is a suspension kit available in order to simplify hanging it at the level desired.

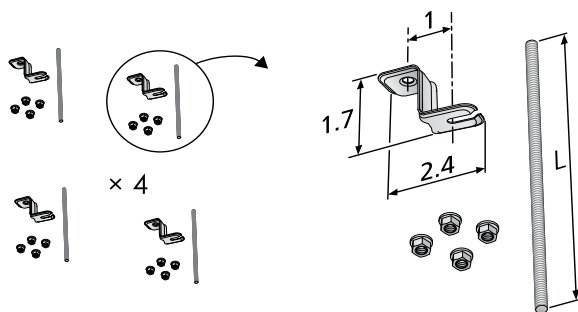

Figure 17. Suspension kit, SYST MS M8 (L = according to ordering key)

## Installation

### Assembly

The PARAGON is delivered with four mounting brackets designed for installation directly against the ceiling or installation suspended from the ceiling. The mounting brackets allow a certain amount of further adjustment after the comfort module/ceiling mounting brackets has/ have been mounted as accurately as possible. This enables you to position the supply spigot correctly in relation to the wall and the grille. The next step is to connect the air duct, cooling pipes and heating pipes.

The SYST MS M8 suspension kit (must be ordered separately) can be used to advantage in applications in which the PARAGON should not be mounted tight against the ceiling. For detailed mounting instructions, see separate document available for downloading at [www.swegon.com](http://www.swegon.com).

### Water connections

All water pipes (supply/return – cooling/heating) are delivered as stub copper pipes with OD 0.5 in. x length 0.04 in..

*NOTE! Support sleeves must be used if compression ring couplings are fitted. It is important use a pipe wrench to adequately restrain the pipe connections when tightening external connections to prevent damage to the connection pipes.*

### Air connection

A 5 in. air duct including gasket is connected directly to a circular connection spigot.

If the supply air kit is included in the installation, connect the parts in the following order, viewed from the PARAGON:

1. Comfort module PARAGON
2. Air duct
3. Sound attenuator CLA
4. Air duct
5. CRT damper

Note that the supply and extract air kit is also available with an OD of 4 in.. This kit is suitable for use if the space is limited and low airflows are discharged into the room.

### Finishing

The work of building the soffit around the terminal can begin when the PARAGON has been completely installed. PARAGON is adapted so that load-bearing T-bar systems in combination with mineral wool slabs or the like could be used to build the soffit. Plasterboard also works well. To make your work simpler, detailed dimensions for cutting the opening are specified below the "Dimensions" section on page 22 in this brochure. More detailed information is also available in separate installation instructions at [www.swegon.com](http://www.swegon.com).

### Maintenance

Since the PARAGON operates without any built-in fan, without filter and without a drainage system, very little maintenance is required. In a hotel room or a hospital room, it is normally sufficient to vacuum clean the back side of the coil every six months to remove loose dust. A simple visual inspection of connections and wiping the supply air grille and return air grille with a damp cloth is also recommended. Avoid aggressive cleaning agents which may harm painted surfaces. Normally a mild soap or alcohol solution is fully adequate for cleaning. Note that the dry operation without condensation minimises the risk of bacteria growth that otherwise is occurs in wet systems.

The requirement for maintenance is yet lower in an office room, since this type of environment is normally much more dust-free, and this allows longer intervals between scheduled maintenance. It is normally enough to clean the coil in an office room once every second year.

PARAGON b

## Dimensions and Weights

**Table 18 - Weight**

NC	RYY Dry	RYN Dry	RNY Dry	RNN Dry	Water volume gallons	
					Cooling	Heating
L	lb	lb	lb	lb		
35	49.4	46.5	45.4	42.5	0.18	0.05
43	57.3	53.8	52.5	48.9	0.21	0.08
51	65.5	61.3	59.7	55.6	0.24	0.09
59	73.4	68.6	66.8	61.9	0.29	0.11
HC	RYY Dry	RYN Dry	RNY Dry	RNN Dry	Water volume gallons	
					Cooling	Heating
L	lb	lb	lb	lb		
35	50.7	47.8	46.7	43.9	0.26	0.05
43	59.5	56.0	62.6	51.1	0.32	0.08
51	68.3	64.2	62.6	58.4	0.36	0.08
59	77.2	72.3	70.5	65.7	0.42	0.11

NOTE! The abbreviations in the table are explained in the Order nomenclature.

**Table 19 - Dimensions**

PARAGON	L	L + 1.65	A	B	L/2
35	35.4	37.1	30.9	29.5	17.7
43	43.3	45.0	38.8	37.4	21.7
51	51.2	52.8	46.7	45.3	25.6
59	59.1	60.7	54.5	53.1	29.5

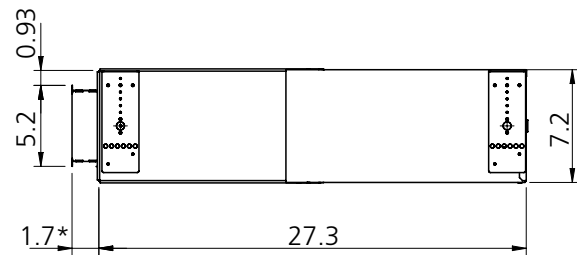

Figure 18. Side view excl. grille

\* with extra spigot = 3.54"  
with telescopic spigot = 3.94-5.51"

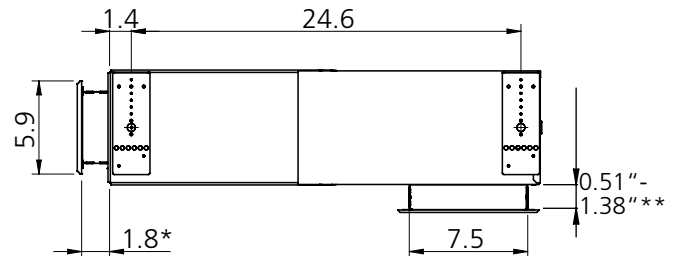

Figure 19. Side view incl. grille

\* with extra spigot = 3.54"  
with telescopic spigot = 3.94-5.51"  
\*\* with extra spigot = 1.38"-2.76"

Connection on the right hand side – R

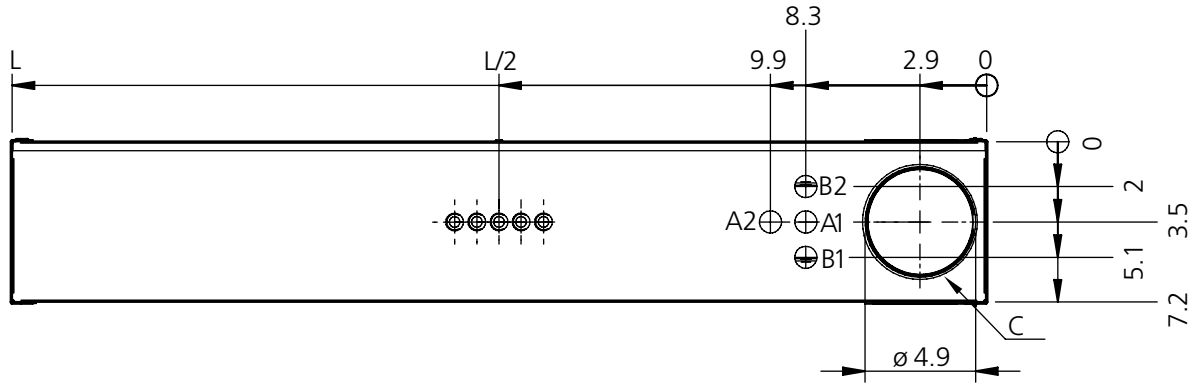

Figure 20. View of the back side with connection on the right-hand side - R.

A1 = Chilled water supply  
B1 = Hot water supply

A2 = Chilled water return  
B2 = Hot water return

C = Supply air  
D = Cable grommets

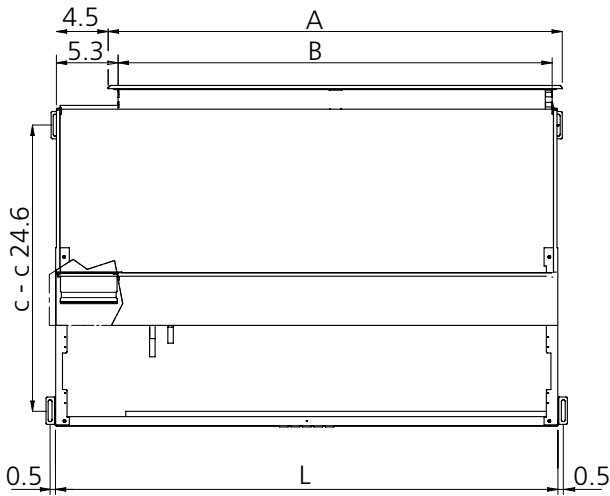

Figure 21a. Bottom view

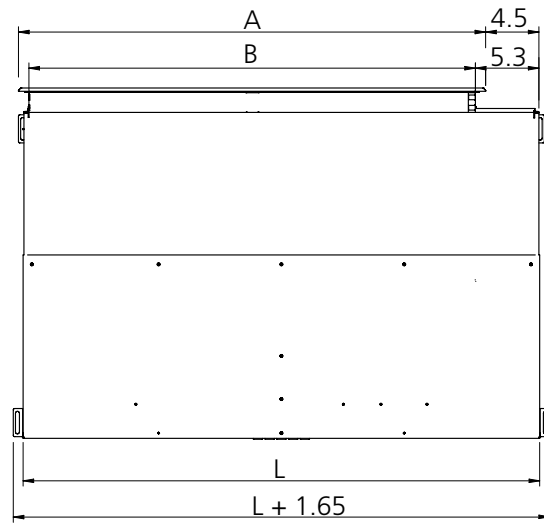

Figure 22. Top view

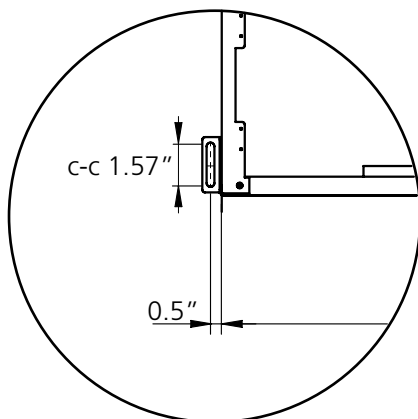

Figure 21b. Mounting bracket

PARAGON b

Connection on the left hand side -L

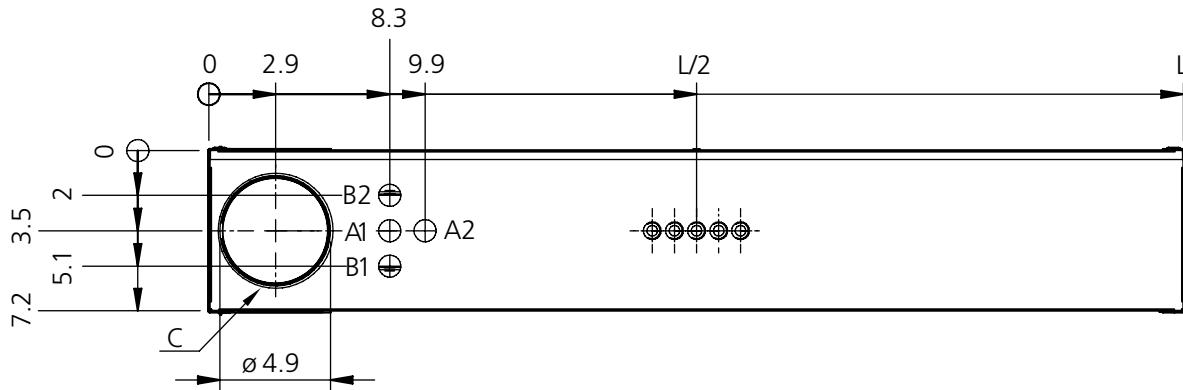

Figure 23. View of the backside, L – left-hand version

A1 = Cooling water, inlet pipe  
 B1 = Heating water, inlet water

A2 = Cooling water, return  
 B2 = Heating water, return

C = Supply air  
 D = Cable grommets

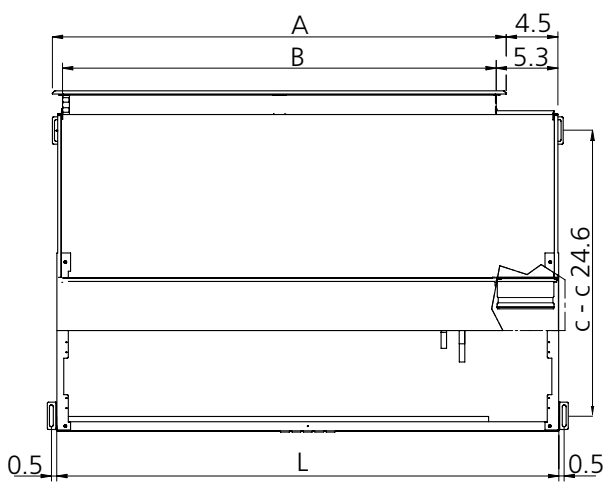

Figure 24 a. Bottom view

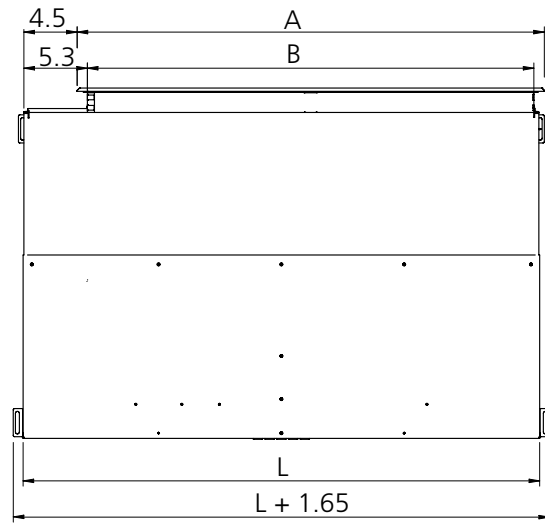

Figure 25. Top view.

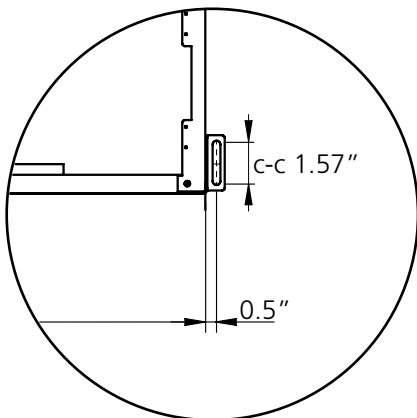

Figure 24 b. Mounting bracket

Dimensions, accessories

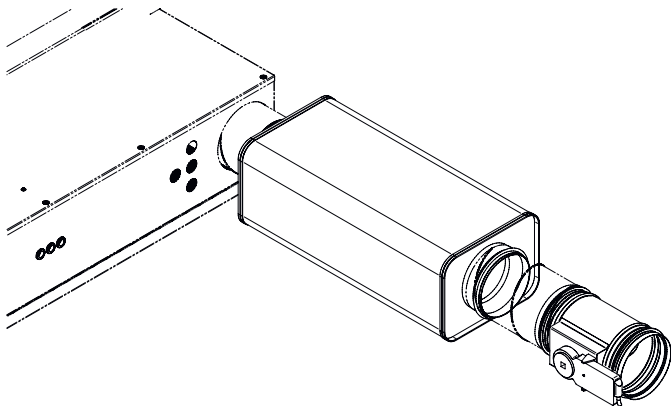

Figure 26. Supply air kit, PARAGON T-SAK-VAV

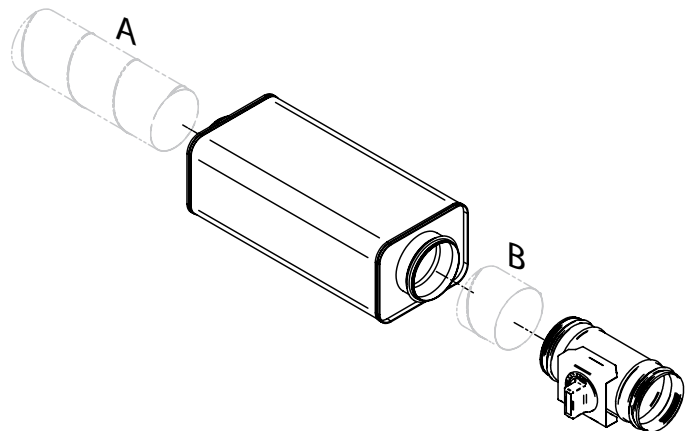

Figure 29. Supply air kit, PARAGON T-SAK-CAV-5

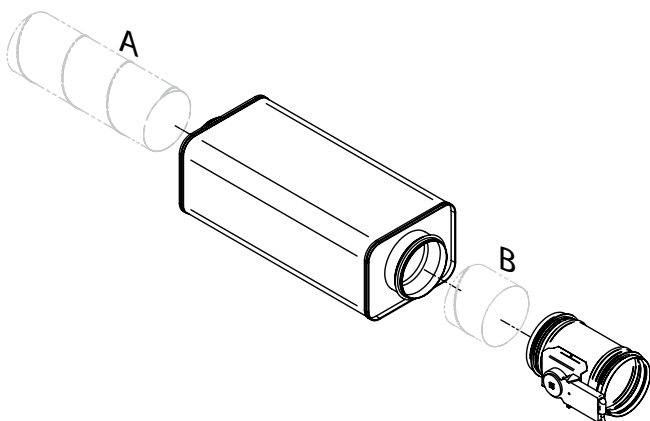

Figure 27. Supply air kit, PARAGON T-SAK-VAV-5

Spiral ducts are not included.  
Spiral duct A: Min. length: 13.0 in.  
Spiral duct B: Min. length: 2.8 in.

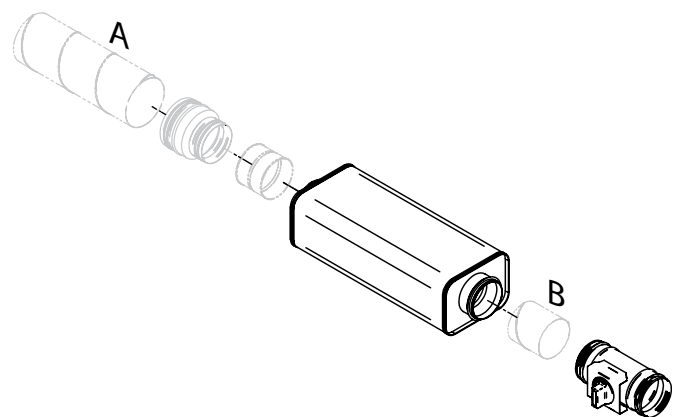

Figure 30. Supply air kit, PARAGON T-SAK-CAV-4

Size 4 spiral ducts and sleeve are not included.  
Spiral duct A: Min. length: 13.0 in.  
Spiral duct B: Min. length: 2.8 in.

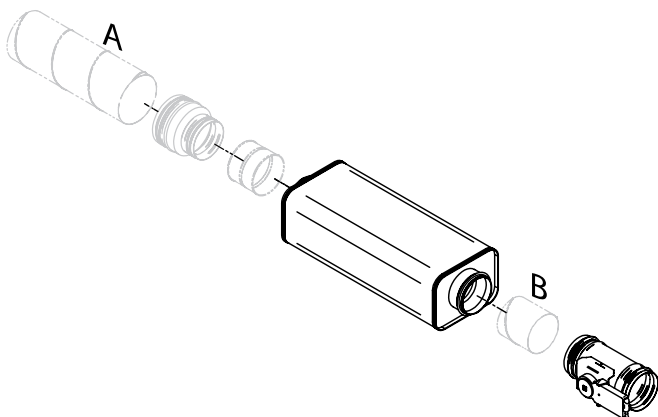

Figure 28. Supply air kit, PARAGON T-SAK-VAV-4

Size 4 spiral ducts and sleeve are not included.  
Spiral duct A: Min. length: 13.0 in.  
Spiral duct B: Min. length: 2.8 in.

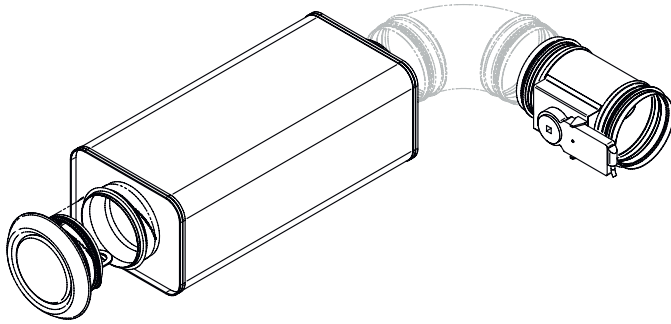

Figure 31. Extract air kit, PARAGON T-EAK

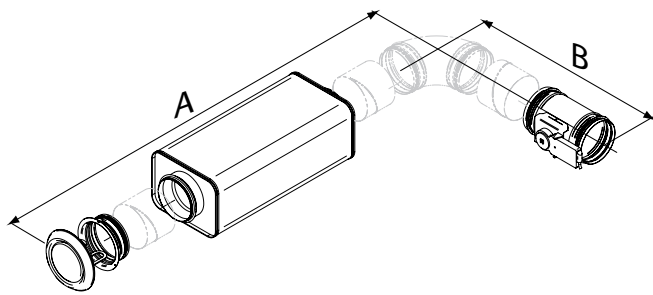

Figure 32. Extract air kit, PARAGON T-EAK-VAV

Available for connection sizes 5 in. and 4 in.  
 Spiral ducts and jointing sleeve are not included  
 A: Min. length: 30.3 in.  
 B: Min. length: 14.2 in.

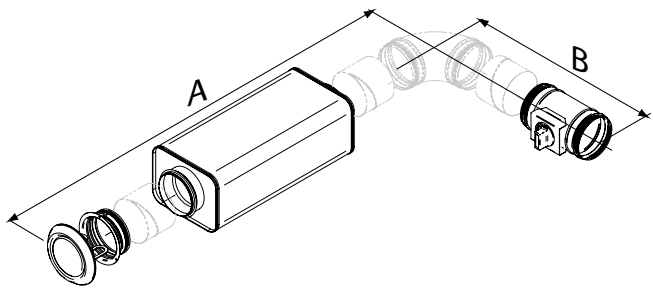

Figure 33. Extract air kit, PARAGON T-EAK-CAV

Available for connection sizes 5 in. and 4 in.  
 Spiral ducts and jointing sleeve are not included  
 A: Min. length: 30.3 in.  
 B: Min. length: 14.2 in.



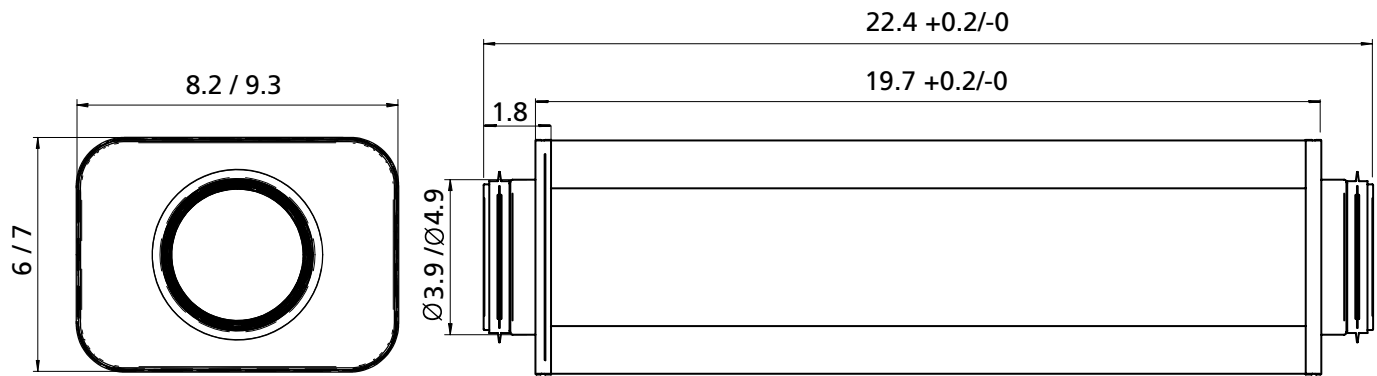

Figure 34. Dimensions CLA sound attenuator. Included in PARAGON T-SAK and PARAGON T-EAK.

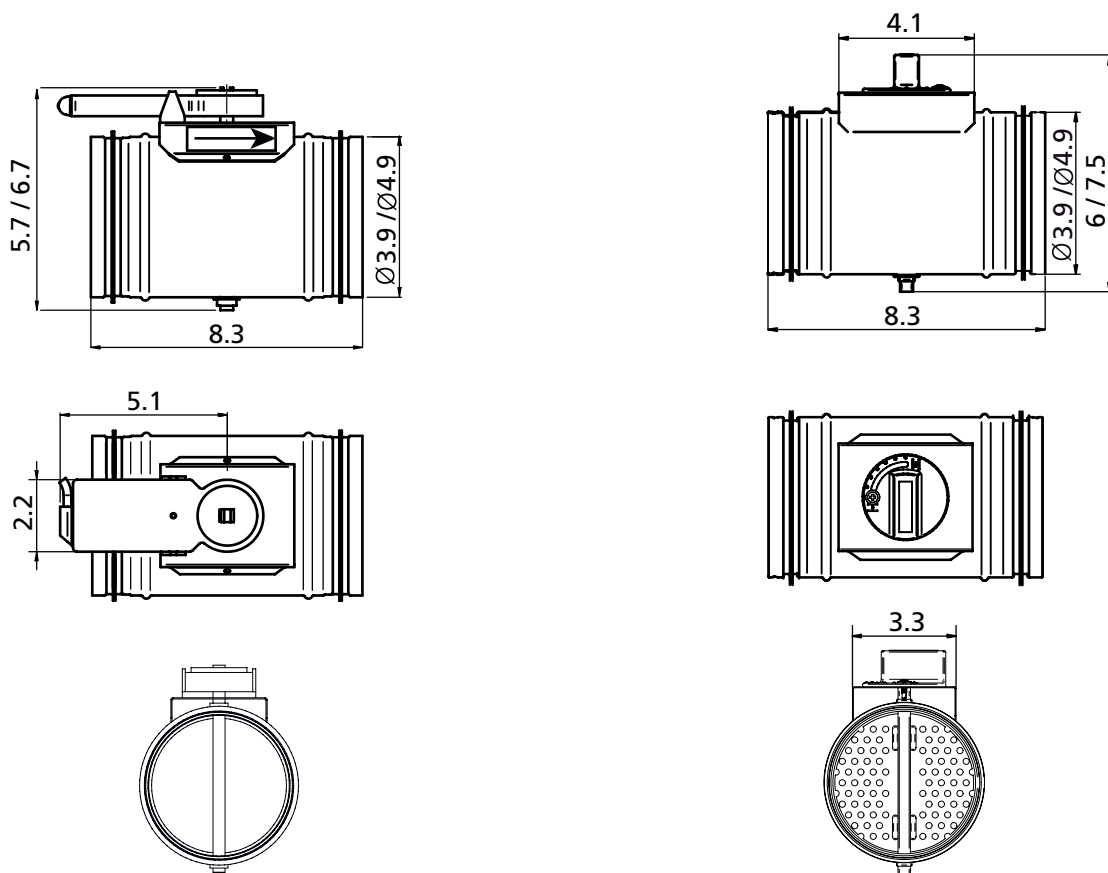

Figure 35. Dimensions CRT motor-driven damper. Included in PARAGON T-SAK-VAV and PARAGON T-EAK-VAV.

Figure 36. Dimensions CRP commissioning damper. Included in PARAGON T-SAK-CAV and PARAGON T-EAK-CAV.

PARAGON b

## Ordering key

### Specification

Type PARAGON comfort module for cooling, heating and ventilation.

### Delivery demarcation

Swegon's limits of supply are at the connection points for water and air.

At these connection points, the plumbing contractor connects to plain pipe end and/or suitable connectors, fills the system, bleeds it and tests the pressure in the circuits.

The ventilation contractor connects to the duct connections with dimensions as specified on the basic size drawing in the section "Dimensions".

The building contractor cuts the openings in the corridor wall for the supply air duct, in the interior wall and suspended ceiling for the supply air and extract air grilles and in the bathroom ceiling for the extract air duct.

### The PARAGON ordering key

PARAGON	b	aaaa-	b-	cc-	d-	ef
Version:						
Length (in.) 35, 43, 51 and 59						
Function: A = Cooling B = Cooling and heating						
Capacity variant NC – Normal version HC – High capacity version						
Connection side R - Right L - Left						
Flow variant Upper nozzle row: L, M, H Lower nozzle row: L, M, H						

### Example:

PARAGON b-43-B-NC-R-LM

Available to order, kit and accessories

Supply air kit	VAV: PARAGON CRTc motor-driven damper with tight damper blade with damper actuator and CLA sound attenuator
	CAV: PARAGON CRPc manually adjustable damper with perforated damper blade and CLA sound attenuator
Extract air kit	VAV: PARAGON CRTc motor-driven damper with tight damper blade with damper actuator, CLA sound attenuator and extract air register with mounting frame.
	CAV: PARAGON CRPc manually adjustable damper with perforated damper blade, CLA sound attenuator and extract air register with mounting frame.
Assembly piece	Ceiling mounting bracket and threaded rod for mounting in ceiling. Double threaded rods with thread lock are also available.
Side mounting brackets	Side mounting brackets for suspending the module, 2 brackets (alternative to standard mounting brackets)
Supply air grille	Supply air grille incl. 1.77" spigot
Extra spigot	Extra 1.77" spigot for the supply air grille, gives a total dimension of 3.54"
Supply air grille with telescopic spigot	Supply air grille incl. telescopic spigot, 3.94"-5.51"
Grill lock	For fixing supply air grille position
Return air grille	Return air grille incl. 0.51"-1.38" spigot
Extra spigot	Extra spigot for the return air grille, gives a total dimension of 1.38"-2.76"

Supply air grille incl. 1.77" mm spigot	PARAGON b T-SG-	aaaa
Length (in.) 35, 43, 51 and 59		

Extra spigot for the supply air grille	PARAGON b T OE-SG	aaaa
Length (in.) 35, 43, 51 and 59		

Supply air grille incl. telescopic spigot, 3.94"-5.51"	PARAGON b TE-SG	aaaa
Length (in.) 35, 43, 51 and 59		

Return air grille incl. 0.51"-1.38" spigot	PARAGON b T RG	aaaa
Length (in.) 35, 43, 51 and 59		

Extra spigot for the return air grille, 1.38"-2.76"	PARAGON b T OE-RG	aaaa
Length (in.) 35, 43, 51 and 59		

Accessory kit

Supply air kit	PARAGON b-	T-SAK-VAV-	bbb
Version:			
Kit with motor-driven damper			
OD 4 in.; OD 5 in.			

Supply air kit	PARAGON b-	T-SAK-CAV-	bbb
Version:			
Kit with manually adjustable damper			
OD 4 in.; OD 5 in.			

Extract air kit	PARAGON b-	T-EAK-VAV-	bbb
Version:			
Kit with motor-driven damper			
OD 4 in.; OD 5 in.			

Extract air kit	PARAGON b-	T-EAK-CAV-	bbb
Version:			
Kit with manually adjustable damper			
OD 4 in.; OD 5 in.			

Ordering Key, Accessories

Assembly piece	SYST MS M8-	aaaa-	b
Length of threaded rod (in.): 7.9; 19.7; 39.4			
Type: 1=One threaded rod 2=Two threaded rods and a thread lock			

PARAGON b