

PARAGON WALL



Compact comfort module

www.eurovent-certification.com
www.certiflash.com



PARAGON WALL

Quick facts

- ▶ Cooling, heating (water or electric) and ventilation
- ▶ Designed for installation in the rear edge of the room
- ▶ Integrated control equipment as an option
- ▶ One grille for both the supply air and the recirculated air
- ▶ Closed system
- ▶ Flexible airflow – VariFlow
- ▶ Adjustable air direction - ADC

Key figures

Airflow range:	10 - 72 l/s
Pressure range:	50 - 200 Pa
Total cooling capacity:	Up to 2300 W
Heating capacity:	Water: Up to 3000 W Electricity: Up to 1000 W
Size:	L=900, 1100, 1300 and 1500 B=680 H=265 mm

Swegon



Figure 1. PARAGON WALL

PARAGON WALL Comfort module

Paragon Wall is the name of a new comfort module that is part of the family of compact comfort modules and is designed especially for rear-edge location in office rooms.

The module is installed above the false ceiling in the corridor outside the room and requires no false ceiling inside the room. By using the same grille both for distribution of supply air and the recirculation of room air, only one grille is visible inside the room.

Technical description

Outstanding features of the PARAGON WALL comfort module

Paragon Wall has been developed for creating a well-performing indoor climate in offices where technical installations are meant to be located in the rear edge of the room.

Strong focus has been directed on a high degree of comfort, low installation costs as well as low running costs in this application. Since the Paragon Wall is driven by a central air handling unit, there is no built-in fan that would otherwise generate sound and require servicing. Through patent-pending technology, the built-in coil is optimally utilized which provides high cooling/heating capacity already while the air pressure and airflows are low.

By using the same grille for both the distribution of supplied air and the recirculation of room air, PARAGON WALL makes a technical installation outside the relevant room possible. This offers several important benefits. By utilising the space above the false ceiling in the adjoining corridor, service can be carried out in the corridor without the need for access to the room served by the unit. With only one grille to take into consideration, only one opening needs to be cut in the wall. PARAGON WALL is, of course, equipped with VariFlow and ADC for simple adjustment of the airflow and direction of air discharge. Vertical air discharge direction can also be set simply by adjusting the angle of the louvers in the grille.

PARAGON WALL in a nutshell

- Plug & play
- Factory-fitted control equipment is optional.
- Low flow-generated sound level
- Draught-free indoor climate
- No fan in the room
- Dry system without condensation
- No need for any drainage system
- No filters
- Requires minimal maintenance
- Low energy consumption
- Flexible adjustment of the air volume (VariFlow)
- Guaranteed comfort through flexible adjustment of the direction of air discharge (ADC)

How the Unit Operates

Office

The primary air is supplied via duct connection in the rear edge of the unit and this builds up positive pressure inside the unit. The positive pressure distributes the primary air with relatively high velocity via two rows of nozzle holes, one row in the upper edge and one row in the lower edge of the outlet. The high velocity of the primary air creates negative pressure which generates induction of the room air.

The recirculation air is sucked into the unit through the same grille that is used for distributing air into the room.

The recirculation air is then conveyed through the coil where it is cooled, heated, if required, or just passes untreated, before it mixes with the primary air and is discharged into the room.

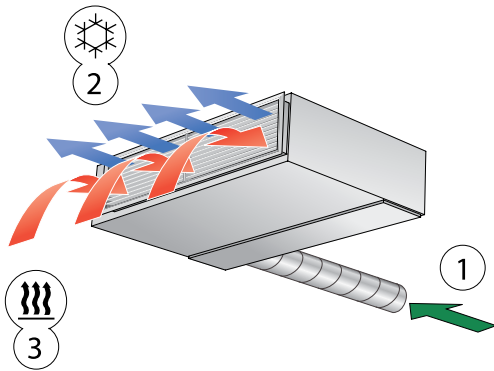

Figure 2 – Paragon Wall cooling function
 1 = Primary air
 2 = Primary air mixed with chilled room air
 3 = Induced room air

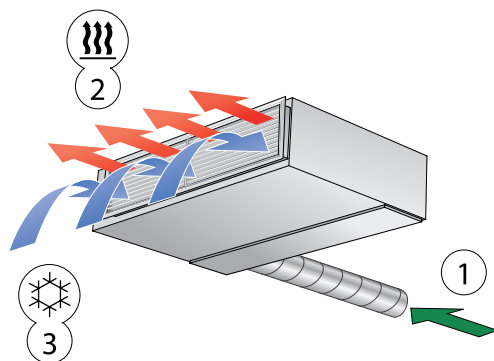

Figure 3 – Paragon Wall heating function
 1 = Primary air
 2 = Primary air mixed with heated room air
 3 = Induced room air

The air is ideally distributed to office rooms by discharging it in a fan shape and utilising as much of the ceiling and any intermediate walls as possible for preventing draughts in the occupied zone.

Horizontal air distribution is achieved by means of the ADC (Anti-Draught Control) feature. If vertical air distribution is desirable, this is achieved by setting the outlet grille vanes to slant upward or downward.

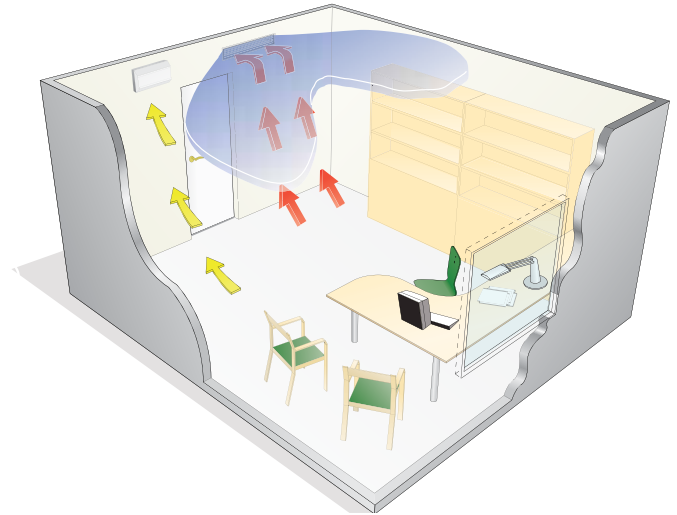

Figure 4. Air distribution with the Paragon Wall in a separate office room

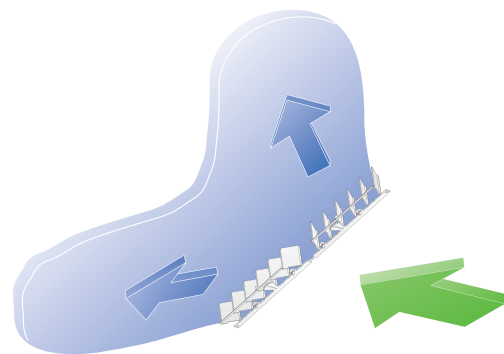

Figure 5 – Horizontal air distribution with ADC

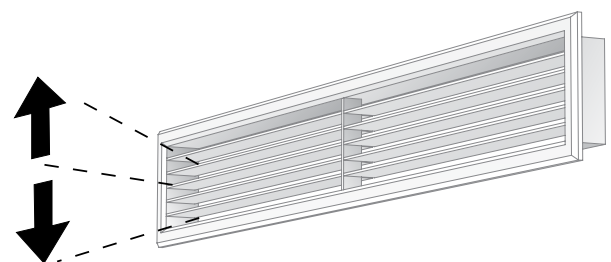

Figure 6. Vertical air distribution with adjustable louvers in the supply air grille



Figure 7. Adjusted nozzle L



Figure 8. Adjusted nozzle M



Figure 9. Nozzle H. Throttling strip removed

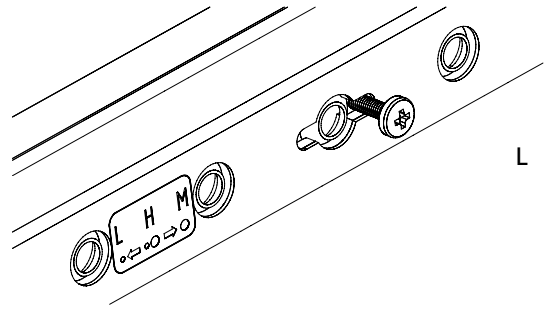

L

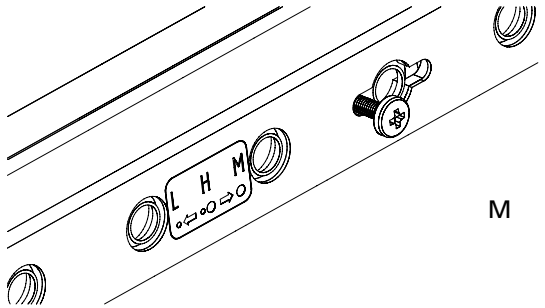

M

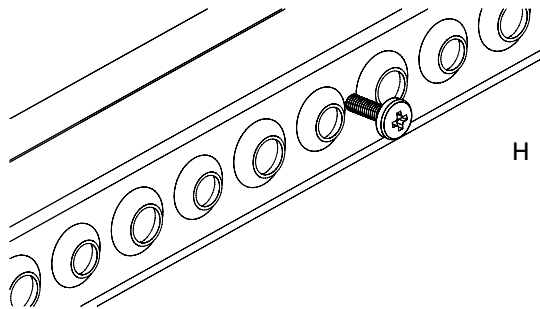

H

Figure 10. Adjustment of nozzles L, M and H (The throttling strip by nozzle H has been removed.)

Optional Extras

CONDUCTOR Control equipment

Energy efficient

The control equipment for the Paragon Wall in the standard version is based on the CONDUCTOR in order to save on energy to the fullest possible extent. The CONDUCTOR is Swegon's in-house designed controller specially designed for controlling water-borne and airborne indoor climate systems.

The W4.1 application used in combination with the PARAGON WALL demand-controls both the room temperature and the air quality in the room. When someone is in the room, the functions of the controller adapt to provide comfort feed-back control. If no one is in the room, the controls activate the economy comfort mode, allowing the room temperature to deviate more from the preset setpoint. At the same time, the system reduces the airflow to the relevant room to a minimum in order to save fan energy. In addition, there are a number of other functions for both comfort and energy feed-back control coupled to temperature deviations, open/closed windows and possible condensation precipitation.

Communication

CONDUCTOR has been developed as a subsystem in Swegon's electrical and control equipment platform. The GOLD air handling units, used in combination with the SuperWISE communication unit, offer unique opportunities for achieving energy-efficient applications all the way from the room level and up to the plant room.

The CONDUCTOR communicates via Modbus RTU Main control systems can access the entire list of parameters for both reading and writing values.

Simple installation and simple maintenance

Factory-fitted control equipment makes the installation work simple. All the necessary components are then easily accessible via an easy-to-remove inspection cover in the underside of the unit.

The room controller included in the supply communicates wirelessly or via wired connection to the comfort module controller. Wireless communication reduces the costs for running cables. On the other hand, a wired connection reduces the need for maintenance since the user then does not need to periodically replace batteries.

For more information regarding the CONDUCTOR, see separate product data sheet.

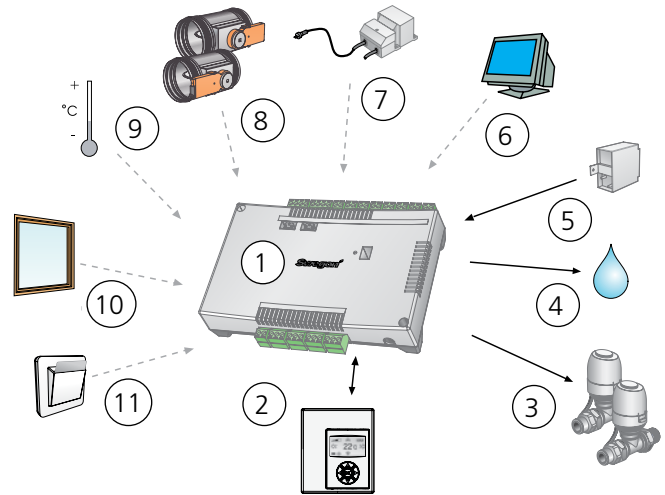

Figure 11. Factory-fitted CONDUCTOR control equipment

- 1 = Controller
- 2 = Room controller
- 3 = Valves and actuators for cooling and heating water
- 4 = Condensation sensor
- 5 = Pressure sensor
- 6 = Communication via Modbus RTU

Accessories, if required:

- 7 = Transformer
- 8 = Motor-driven ventilation dampers
- 9 = External temperature sensor
- 10 = Window contact
- 11 = Key card holder or presence detector



Figure 12. Factory-fitted CONDUCTOR W4.1

Optional Extras

LUNA control equipment

A simpler form of control equipment is available in applications where the user does not want demand-controlled ventilation in the room and has no need of communication with an external monitoring system. This variant of control is called LUNA and regulates the temperature in the room only (not the air quality). Paragon Wall with factory-fitted LUNA is available to order.

Please note that the controller in this case is incorporated into the room controller and requires a cable connection from the room to the actuator and possibly to the condensation sensor up inside the Paragon Wall. For more information, see the separate datasheet for the LUNA.

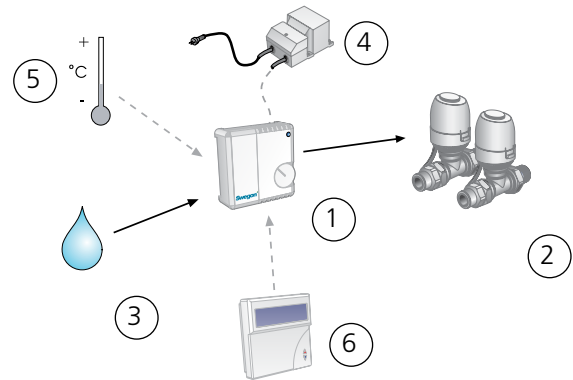

Figure 14. Factory-fitted LUNA control equipment

- 1 = Room controller with room thermostat
- 2 = Valves and valve actuators for cooling and heating water
- 3 = Condensation sensor

Accessories, if required:

- 4 = Transformer
- 5 = External temperature sensor
- 6 = Hand unit for changing the factory settings



Figure 13. Factory-fitted LUNA-CH

Project Design

Both planning and sizing are made easier by using Swegon's ProSelect Project design computer program. ProSelect is available at Swegon's home page: www.swegon.com.

Sizing

Designations

P:	Capacity (W, kW)
v:	Velocity (m/s)
q:	Airflow (l/s)
p:	Pressure, (Pa, kPa)
t_r :	Room temperature (°C)
t_m :	Mean water temperature (°C)
ΔT_m :	Temperature difference [$t_r - t_m$] (K)
ΔT :	Temperature difference, between inlet and return (K)
ΔT_i :	Temperature difference, between room and supply air (K)
Δp :	Pressure drop (Pa, kPa)
k_p :	Pressure drop constant

Supplementary index:
k = cooling, l = air, v = heating, i = commissioning

Recommended limit values, water

Max. recommended operating pressure (above coil only):	1600 kPa
Max. recommended test pressure (across coil only):	2400 kPa
Max. recommended pressure drop across standard valve:	20 kPa
Min. permissible hot water flow:	0.013 l/s
Max. permissible inlet flow temperature:	60 °C
Min. permissible cooling water flow:	0.03 l/s
Lowest permissible inlet flow temperature:	Should always be sized so that the system operates without condensation

Cooling

Cooling capacity

Cooling capacities achieved from both the primary air and chilled water for various lengths of unit, damper settings and airflows are tabulated in Table 1. The total cooling capacity for one unit is the sum of the cooling capacity of the primary air and the chilled water.

The cooling capacity of the primary air can also be calculated using the formula:

$P_1 = 1.2 \cdot q_1 \cdot \Delta T_1$ where

P_1 = Cooling capacity of the air (W)

q_1 = Airflow (l/s)

ΔT_1 = Temperature differential (K)

Pressure drop

The pressure drop on the water side can be calculated using the formula:

$\Delta p = (q / k_{pk})^2$ where

Δp = Pressure drop in the water circuit (kPa)

q = Water flow (l/s), see Diagram 1

k_{pk} = Pressure drop constant read from Table 1.

Capacity correction

Different water flows influence the available cooling effect to a certain degree. To calculate the actual cooling power based on a flow-dependant correction factor, use Swegon's ProSelect computer program, available at www.swegon.com.

Table 1. Pressure drop

Pressure drop, water		
NC	Length	K_{pk} Cooling
	900	0.0217
	1100	0.0202
	1300	0.0190
HC	Length	K_{pk} Cooling
	900	0.0186
	1100	0.0174
	1300	0.0164
	1500	0.0155

NC = Normal version

HC = High capacity version

Table 2. Cooling Capacity for Natural Convection

Natural convection: The cooling capacity of water (W) for ΔT_{mv}								
Size	5	6	7	8	9	10	11	12
900	16	19	23	26	30	33	37	40
1100	20	25	29	34	38	43	47	52
1300	25	30	36	41	47	52	58	63
1500	30	36	42	49	55	62	68	75

Diagram 1 – Cooling capacity

The function between cooling capacity P_k (W), change in temperature ΔT_k (K) and cooling water flow q_k (l/s).

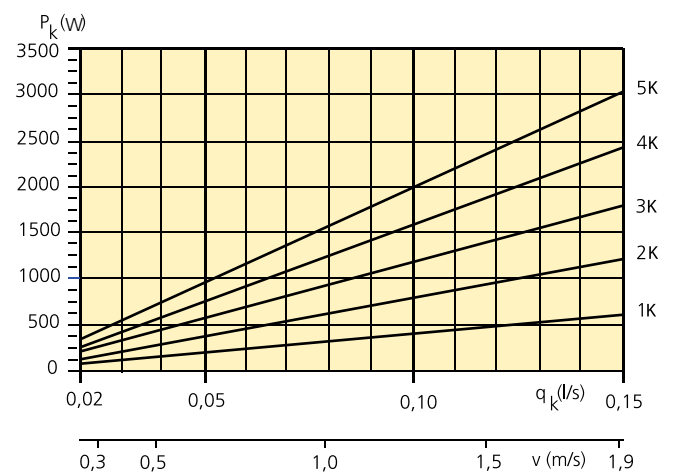

Diagram 2. Water flow – capacity correction

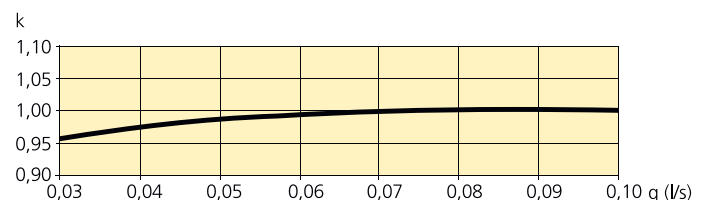

Table 3 – Cooling capacity, NC, 70 Pa

Length of the unit	Nozzle setting		Air-flow	Sound level ¹	p _i	Cooling capacity, primary air (W) ΔT _i				Cooling capacity of water (W) for ΔT _{mk} ²							Pressure drop constant, air
										6	7	8	9	10	11	12	
mm			l/s	dB (A)	Pa	6	8	10	12	6	7	8	9	10	11	12	k _{pl}
900	L	L	12.5	<20	70	90	120	150	180	221	258	294	331	367	403	440	1.50
900	M	M	15.8	20	70	114	152	190	228	244	284	324	364	404	444	484	1.89
900	H	H	27.1	21	70	195	260	325	390	292	339	386	432	478	524	569	3.24
1100	L	L	16.2	<20	70	117	156	194	233	286	334	381	428	475	522	569	1.94
1100	M	M	20.4	21	70	147	196	245	294	314	366	418	469	521	573	624	2.44
1100	H	H	35.1	23	70	253	337	421	505	378	439	499	558	618	677	736	4.19
1300	L	L	19.4	<20	70	140	186	233	279	352	410	468	526	584	642	700	2.32
1300	M	M	24.4	22	70	176	234	293	351	386	449	513	576	639	703	766	2.92
1300	H	H	41.8	24	70	301	401	502	602	462	536	609	682	755	828	900	5.00
1500	L	L	16.5	22	70	119	158	198	238	371	435	499	564	630	695	761	1.97
1500	M	M	28.0	23	70	202	269	336	403	447	524	600	677	753	830	907	3.35
1500	H	H	42.8	27	70	308	411	514	616	535	622	708	794	879	965	1050	5.12

Table 4 – Cooling capacity, NC, 100 Pa

Length of the unit	Nozzle setting		Air-flow	Sound level ¹	p _i	Cooling capacity, primary air (W) ΔT _i				Cooling capacity of water (W) for ΔT _{mk} ²							Pressure drop constant, air
										6	7	8	9	10	11	12	
mm			l/s	dB (A)	Pa	6	8	10	12	6	7	8	9	10	11	12	k _{pl}
900	L	L	15.0	<20	100	108	144	180	216	265	308	350	393	436	478	521	1.50
900	M	M	18.9	25	100	136	181	227	272	290	336	383	429	476	522	568	1.89
900	H	H	32.4	26	100	233	311	389	467	342	397	452	506	560	614	668	3.24
1100	L	L	19.4	<20	100	140	186	233	279	342	397	453	508	563	617	672	1.94
1100	M	M	24.4	26	100	176	234	293	351	373	434	494	554	613	673	732	2.44
1100	H	H	41.9	28	100	302	402	503	603	442	513	583	653	723	793	862	4.19
1300	L	L	23.2	20	100	167	223	278	334	419	487	555	623	690	757	825	2.32
1300	M	M	29.2	27	100	210	280	350	420	458	532	606	679	753	826	899	2.92
1300	H	H	50.0	29	100	360	480	600	720	541	628	714	800	886	971	1056	5.00
1500	L	L	19.7	27	100	142	189	236	284	444	519	594	669	745	820	896	1.97
1500	M	M	33.5	28	100	241	322	402	482	532	621	710	798	887	976	1065	3.35
1500	H	H	51.2	32	100	369	492	614	737	623	724	825	925	1025	1125	1224	5.12

PARAGON WALL

1) The specified sound level is applicable to connection without damper or with fully open damper. In other cases where the airflow is demand-controlled with motor-driven dampers, the required data can be read from Swegon's ProSelect sizing program. Room attenuation = 4 dB

2) The specified capacities are based on a complete unit including standard distribution and recirculation grille. Without grille the water capacity increases by approx. 5%. With ADC adjusted to Fan shape you lose approx. 5% in water capacity. The primary air capacity is not affected.

N.B.! The total cooling capacity is the sum of the air-based and water-based cooling capacities.

Table 5 – Cooling capacity, NC, 150 Pa

Length of the unit	Nozzle setting		Air-flow	Sound level ¹	p _i	Cooling capacity, primary air (W) ΔT _i				Cooling capacity of water (W) for ΔT _{mk} ²							Pressure drop constant, air
										6	7	8	9	10	11	12	
mm			l/s	dB (A)	Pa	6	8	10	12	6	7	8	9	10	11	12	k _{pl}
900	L	L	18.4	24	150	132	177	221	265	314	364	414	463	513	562	611	1.50
900	M	M	23.1	31	150	166	222	277	333	341	395	449	502	556	609	662	1.89
900	H	H	39.7	32	150	286	381	476	572	398	463	527	590	654	717	780	3.24
1100	L	L	23.8	25	150	171	228	286	343	405	470	534	598	662	726	789	1.94
1100	M	M	29.9	32	150	215	287	359	431	440	510	580	649	718	787	855	2.44
1100	H	H	51.3	33	150	369	492	616	739	514	597	679	762	844	925	1007	4.19
1300	L	L	28.4	26	150	204	273	341	409	496	575	654	732	811	888	966	2.32
1300	M	M	35.8	33	150	258	344	430	516	540	626	712	797	881	965	1049	2.92
1300	M	H	48.5	34	150	349	466	582	698	597	692	788	883	977	1071	1165	3.96
1500	L	L	24.1	31	150	174	231	289	347	528	615	702	789	876	962	1049	1.97
1500	M	M	41.0	33	150	295	394	492	590	627	730	833	936	1038	1141	1243	3.35
1500	M	H	51.9	35	150	374	498	623	747	685	797	908	1019	1130	1241	1352	4.24

Table 6 – Cooling capacity, NC, 200 Pa

Length of the unit	Nozzle setting		Air-flow	Sound level ¹	p _i	Cooling capacity, primary air (W) ΔT _i				Cooling capacity of water (W) for ΔT _{mk} ²							Pressure drop constant, air
										6	7	8	9	10	11	12	
mm			l/s	dB (A)	Pa	6	8	10	12	6	7	8	9	10	11	12	k _{pl}
900	L	L	21.2	29	200	153	204	254	305	347	402	457	512	566	620	674	1.50
900	M	M	26.7	35	200	192	256	320	384	378	437	496	555	614	672	730	1.89
1100	L	L	27.4	30	200	197	263	329	395	448	519	590	660	730	800	869	1.94
1100	M	M	34.5	36	200	248	331	414	497	487	564	641	716	792	867	941	2.44
1300	L	L	32.8	31	200	236	315	394	472	550	637	724	810	896	982	1067	2.32
1300	M	M	41.3	37	200	297	396	496	595	598	692	786	879	971	1063	1155	2.92
1500	L	L	27.9	35	200	201	268	335	402	589	685	780	876	971	1066	1160	1.97
1500	M	M	47.4	38	200	341	455	569	683	696	809	922	1034	1147	1259	1371	3.35

1) The specified sound level is applicable to connection without damper or with fully open damper. In other cases where the airflow is demand-controlled with motor-driven dampers, the required data can be read from Swegon's ProSelect sizing program. Room attenuation = 4 dB

2) The specified capacities are based on a complete unit including standard distribution and recirculation grille. Without grille the water capacity increases by approx. 5%. With ADC adjusted to Fan shape you lose approx. 5% in water capacity. The primary air capacity is not affected.

N.B.! The total cooling capacity is the sum of the air-based and water-based cooling capacities.

Table 7 – Cooling capacity, HC, 70 Pa

Length of the unit mm	Nozzle setting		Air-flow l/s	Sound level ¹ dB (A)	p _i Pa	Cooling capacity, primary air (W) ΔT _i				Cooling capacity of water (W) for ΔT _{mk} ²							Pressure drop constant, air k _{pl}
						6	8	10	12	6	7	8	9	10	11	12	
900	L	L	12.5	<20	70	90	120	150	180	226	264	301	338	376	413	450	1.50
900	M	M	15.8	20	70	114	152	190	228	254	296	338	380	422	463	505	1.89
900	H	H	27.1	21	70	195	260	325	390	315	365	415	464	514	563	612	3.24
1100	L	L	16.2	<20	70	117	156	194	233	293	341	390	438	486	535	583	1.94
1100	M	M	20.4	21	70	147	196	245	294	328	382	436	490	544	597	651	2.44
1100	H	H	35.1	23	70	253	337	421	505	407	472	537	601	665	729	792	4.19
1300	L	L	19.4	<20	70	140	186	233	279	360	420	479	539	598	657	717	2.32
1300	M	M	24.4	22	70	176	234	293	351	403	469	535	601	667	733	799	2.92
1300	H	H	41.8	24	70	301	401	502	602	497	577	655	734	812	890	968	5.00
1500	L	L	16.5	22	70	119	158	198	238	380	445	511	578	645	712	779	1.97
1500	M	M	28.0	23	70	202	269	336	403	467	538	617	696	775	854	934	3.35
1500	H	H	42.8	27	70	308	411	514	616	576	669	762	854	946	1038	1129	5.12

Table 8 – Cooling capacity, HC, 100 Pa

Length of the unit mm	Nozzle setting		Air-flow l/s	Sound level ¹ dB (A)	p _i Pa	Cooling capacity, primary air (W) ΔT _i				Cooling capacity of water (W) for ΔT _{mk} ²							Pressure drop constant, air k _{pl}
						6	8	10	12	6	7	8	9	10	11	12	
900	L	L	15.0	<20	100	108	144	180	216	278	323	368	413	457	502	546	1.50
900	M	M	18.9	25	100	136	181	227	272	310	360	410	459	509	558	607	1.89
900	H	H	32.4	26	100	233	311	389	467	376	437	497	556	616	675	735	3.24
1100	L	L	19.4	<20	100	140	186	233	279	359	417	475	533	591	648	705	1.94
1100	M	M	24.4	26	100	176	234	293	351	399	464	528	592	656	719	783	2.44
1100	H	H	41.9	28	100	302	402	503	603	486	564	641	718	795	872	948	4.19
1300	L	L	23.2	20	100	167	223	278	334	440	512	583	654	725	795	866	2.32
1300	M	M	29.2	27	100	210	280	350	420	490	569	648	727	805	883	961	2.92
1300	H	H	50.0	29	100	360	480	600	720	595	690	785	880	974	1068	1161	5.00
1500	L	L	19.7	27	100	142	189	236	284	466	545	624	703	782	861	940	1.97
1500	M	M	33.5	28	100	241	322	402	482	568	652	745	838	933	1026	1119	3.35
1500	H	H	51.2	32	100	369	492	614	737	685	796	907	1017	1127	1237	1346	5.12

1) The specified sound level is applicable to connection without damper or with fully open damper. In other cases where the airflow is demand-controlled with motor-driven dampers, the required data can be read from Swegon's ProSelect sizing program. Room attenuation = 4 dB

2) The specified capacities are based on a complete unit including standard distribution and recirculation grille. Without grille the water capacity increases by approx. 5%. With ADC adjusted to Fan shape you lose approx. 5% in water capacity. The primary air capacity is not affected.

N.B.! The total cooling capacity is the sum of the air-based and water-based cooling capacities.

Table 9 – Cooling capacity, HC, 150 Pa

Length of the unit	Nozzle setting		Air-flow	Sound level ¹	p _i	Cooling capacity, primary air (W) ΔT _i				Cooling capacity of water (W) for ΔT _{mk} ²							Pressure drop constant, air
										6	7	8	9	10	11	12	
mm			l/s	dB (A)	Pa	6	8	10	12	6	7	8	9	10	11	12	k _{pl}
900	L	L	18.4	24	150	132	177	221	265	336	389	443	496	549	602	654	1.50
900	M	M	23.1	31	150	166	222	277	333	372	431	490	548	606	664	722	1.89
900	H	H	39.7	32	150	286	381	476	572	446	518	590	661	732	803	874	3.24
1100	L	L	23.8	25	150	171	228	286	343	433	503	572	640	709	777	845	1.94
1100	M	M	29.9	32	150	215	287	359	431	480	557	632	708	783	858	932	2.44
1100	H	H	51.3	33	150	369	492	616	739	576	669	761	853	945	1036	1127	4.19
1300	L	L	28.4	26	150	204	273	341	409	531	616	700	784	868	951	1034	2.32
1300	M	M	35.8	33	150	258	344	430	516	590	683	777	869	962	1053	1145	2.92
1300	M	H	48.5	34	150	349	466	582	698	663	769	875	980	1085	1189	1294	3.96
1500	L	L	24.1	31	150	174	231	289	347	565	658	751	844	937	1030	1123	1.97
1500	M	M	41.0	33	150	295	394	492	590	683	805	918	1030	1145	1255	1367	3.35
1500	M	H	51.9	35	150	374	498	623	747	759	887	1011	1135	1259	1381	1504	4.24

Table 10 – Cooling capacity, HC, 200 Pa

Length of the unit	Nozzle setting		Air-flow	Sound level ¹	p _i	Cooling capacity, primary air (W) ΔT _i				Cooling capacity of water (W) for ΔT _{mk} ²							Pressure drop constant, air
										6	7	8	9	10	11	12	
mm			l/s	dB (A)	Pa	6	8	10	12	6	7	8	9	10	11	12	k _{pl}
900	L	L	21.2	29	200	153	204	254	305	376	435	495	554	612	671	729	1.50
900	M	M	26.7	35	200	192	256	320	384	416	482	547	612	677	741	804	1.89
1100	L	L	27.4	30	200	197	263	329	395	485	562	638	714	790	865	940	1.94
1100	M	M	34.5	36	200	248	331	414	497	537	622	706	790	873	956	1038	2.44
1300	L	L	32.8	31	200	236	315	394	472	595	690	783	877	970	1062	1154	2.32
1300	M	M	41.3	37	200	297	396	496	595	659	763	867	969	1071	1173	1274	2.92
1500	L	L	27.9	35	200	201	268	335	402	637	741	844	947	1050	1153	1255	1.97
1500	M	M	47.4	38	200	341	455	569	683	765	935	1064	1192	1324	1447	1574	3.35

1) The specified sound level is applicable to connection without damper or with fully open damper. In other cases where the airflow is demand-controlled with motor-driven dampers, the required data can be read from Swegon's ProSelect sizing program. Room attenuation = 4 dB

2) The specified capacities are based on a complete unit including standard distribution and recirculation grille. Without grille the water capacity increases by approx. 5%. With ADC adjusted to Fan shape you lose approx. 5% in water capacity. The primary air capacity is not affected.

N.B.! The total cooling capacity is the sum of the air-based and water-based cooling capacities.

Heating

Pressure drop

The pressure drop on the water side can be calculated using the formula:

$$\Delta p = (q / k_{pv})^2 \text{ where}$$

Δp = Pressure drop in the water circuit (kPa)

q = Water flow (l/s), see Diagram 3

k_{pv} = Pressure drop constant read from Table 11.

For more detailed pressure drop calculation, use the Swegon ProSelect software available at www.swegon.com.

Table 11. Pressure drop

Pressure drop, water		
NC/HC	Length	K_{pv}
	900	0.0178
	1100	0.0166
	1300	0.0156
	1500	0.0148

NC = Normal version

HC = High capacity version

Diagram 3 - Heating capacity

The function between cooling capacity P_v (W), change in temperature ΔT_v (K) and heating water flow, q_v (l/s).

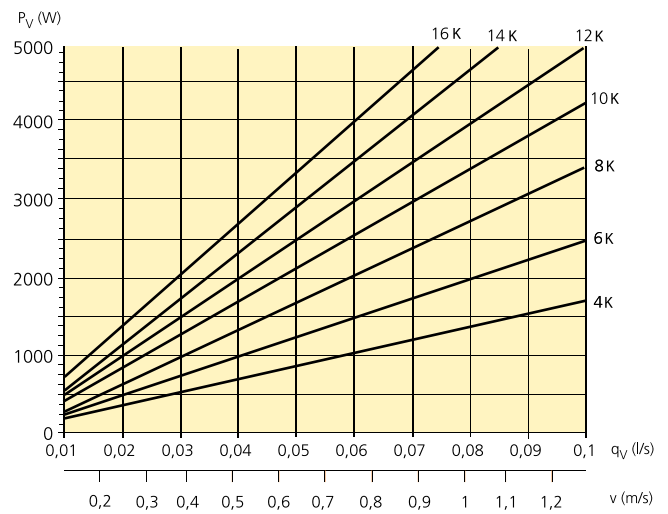

Table 12 - Heating capacity for natural convection

Length	Heat emission when ΔT_{mv} [K] (W)						
	5	10	15	20	25	30	35
900	2	7	14	24	35	49	64
1100	3	9	18	31	46	63	83
1300	3	11	22	37	56	77	102
1500	4	13	26	44	66	92	121

Table 13 - Electric heating

Length	Capacity
900	400 W
1100	800 W
1300	1000 W
1500	1000 W

Table 14 – Heating capacity, NC/HC, 70 Pa

Length of the unit mm	Nozzle setting		Airflow l/s	Sound level ¹ dB (A)	p _i Pa	Heating capacity, water (W) for ΔT _{mv}							Pressure drop constant, air k _{pl}
						5	10	15	20	25	30	35	
900	L	L	12.5	<20	70	106	212	319	427	535	644	753	1.50
900	M	M	15.8	20	70	135	270	404	538	672	806	833	1.89
900	H	H	27.1	21	70	142	285	435	586	740	894	1050	3.24
1100	L	L	16.2	<20	70	137	274	413	552	693	833	974	1.94
1100	M	M	20.4	21	70	174	348	521	694	866	1039	1075	2.44
1100	H	H	35.1	23	70	184	368	562	757	956	1155	1357	4.19
1300	L	L	19.4	<20	70	168	337	508	679	851	1023	1196	2.32
1300	M	M	24.4	22	70	213	427	639	851	1063	1275	1318	2.92
1300	H	H	41.8	24	70	225	450	688	926	1169	1413	1660	5.00
1500	L	L	16.5	22	70	199	398	601	803	1007	1210	1415	1.97
1500	M	M	28.0	23	70	252	504	755	1005	1256	1506	1558	3.35
1500	H	H	42.8	27	70	266	532	814	1096	1384	1672	1964	5.12

Table 15 – Heating capacity, NC/HC, 100 Pa

Length of the unit mm	Nozzle setting		Airflow l/s	Sound level ¹ dB (A)	p _i Pa	Heating capacity, water (W) for ΔT _{mv}							Pressure drop constant, air k _{pl}
						5	10	15	20	25	30	35	
900	L	L	15.0	<20	100	126	251	378	504	630	757	883	1.50
900	M	M	18.9	25	100	155	311	463	615	767	918	950	1.89
900	H	H	32.4	26	100	158	316	485	653	826	1000	1175	3.24
1100	L	L	19.4	<20	100	162	325	488	650	814	977	1140	1.94
1100	M	M	24.4	26	100	200	401	597	793	988	1184	1225	2.44
1100	H	H	41.9	28	100	204	408	626	843	1067	1290	1517	4.19
1300	L	L	23.2	20	100	199	398	598	798	998	1198	1399	2.32
1300	M	M	29.2	27	100	246	492	733	973	1213	1452	1503	2.92
1300	H	H	50.0	29	100	250	499	766	1033	1306	1580	1858	5.00
1500	L	L	19.7	27	100	235	470	707	943	1179	1416	1652	1.97
1500	M	M	33.5	28	100	290	581	865	1150	1433	1716	1775	3.35
1500	H	H	51.2	32	100	296	591	907	1222	1546	1870	2199	5.12

1) The specified sound level is applicable to connection without damper or with fully open damper. In other cases where the airflow is demand-controlled with motor-driven dampers, the required data can be read from Swegon's ProSelect sizing program. Room attenuation = 4 dB

Table 16 – Heating capacity, NC/HC, 150 Pa

Length of the unit mm	Nozzle setting		Airflow l/s	Sound level ¹ dB(A)	p _i Pa	Heating capacity, water (W) for ΔT _{mv}							Pressure drop constant, air k _{pl}
						5	10	15	20	25	30	35	
900	L	L	18.4	24	150	148	296	443	590	736	883	1029	1.50
900	M	M	23.1	31	150	178	357	529	701	872	1043	1079	1.89
900	H	H	39.7	32	150	176	351	540	729	924	1118	1316	3.24
1100	L	L	23.8	25	150	191	382	572	761	951	1140	1329	1.94
1100	M	M	29.9	32	150	230	460	683	906	1126	1346	1394	2.44
1100	H	H	51.3	33	150	227	453	697	941	1192	1443	1698	4.19
1300	L	L	28.4	26	150	234	468	700	932	1164	1396	1627	2.32
1300	M	M	35.8	33	150	283	565	838	1112	1382	1652	1710	2.92
1300	M	H	48.5	34	150	279	558	848	1137	1431	1724	1944	3.96
1500	L	L	24.1	31	150	276	553	827	1101	1375	1648	1922	1.97
1500	M	M	41.0	33	150	334	667	990	1312	1631	1951	2019	3.35
1500	M	H	51.9	35	150	331	661	1003	1344	1691	2037	2288	4.24

Table 17 – Heating capacity, NC/HC, 200 Pa

Length of the unit mm	Nozzle setting		Airflow l/s	Sound level ¹ dB (A)	p _i Pa	Heating capacity, water (W) for ΔT _{mv}							Pressure drop constant, air k _{pl}
						5	10	15	20	25	30	35	
900	L	L	21.2	29	200	163	327	488	649	810	970	1130	1.50
900	M	M	26.7	35	200	195	389	576	763	948	1132	1172	1.89
1100	L	L	27.4	30	200	211	422	630	838	1045	1252	1458	1.94
1100	M	M	34.5	36	200	251	502	744	985	1223	1461	1512	2.44
1300	L	L	32.8	31	200	259	518	773	1028	1282	1536	1789	2.32
1300	M	M	41.3	37	200	308	616	912	1208	1500	1792	1855	2.92
1500	L	L	27.9	35	200	306	612	914	1216	1517	1817	2117	1.97
1500	M	M	47.4	38	200	364	729	1079	1428	1773	2118	2193	3.35

1) The specified sound level is applicable to connection without damper or with fully open damper. In other cases where the airflow is demand-controlled with motor-driven dampers, the required data can be read from Swegon's ProSelect sizing program. Room attenuation = 4 dB

Example

Cooling

Conditions

An individual office room having dimensions $L \times W \times H = 4.2 \times 2.4 \times 2.7$ m is to be ventilated, cooled and heated by the PARAGON WALL. The cooling demand is estimated to be 60 W/m^2 which in the relevant room is recalculated to $4.2 \times 2.4 \times 60 = 605 \text{ W}$.

The supply airflow should be 19 l/s and have a temperature of 15°C . Available duct pressure is maintained constant to 120 Pa. The sound level from the unit must not exceed 27 dB(A).

The design room temperature in the summer case is set to 24°C . The inlet temperature of the cooling water is 14°C and its outlet temperature on returning is 16°C .

Solution

The 15°C supply air temperature and the 24°C room temperature provide $\Delta T_i = 9 \text{ K}$.

The temperature increase of the cooling water is $16 - 14 = 2 \text{ K}$.

The mean temperature of the cooling water is $(14 + 16) / 2 = 15^\circ\text{C}$.

The 15°C mean temperature of the cooling water and the 24°C room temperature provide $\Delta T_{mk} = 9 \text{ K}$.

Calculate the cooling capacity of the supply air: $P_i = 1.2 \times 19 \times 9 = 205 \text{ W}$.

The residual cooling capacity required by the cooling water will be: $605 - 205 = 400 \text{ W}$.

In Table 4, we read that a PARAGON WALL 900 NC with MM nozzle adjustment MM produces 429 W in cooling capacity for 19 l/s supply airflow, 100 Pa nozzle pressure and $\Delta T_{mk} = 9 \text{ K}$. This is sufficient for managing the cooling load.

From Diagram 1 we read a capacity of 429 W and a 2K decrease in heating water temperature as well as a water flow of approx. 0,051 l/s. By means of the water flow and the pressure drop constant k_{pk} which is taken from Table 1, the pressure drop across the coil will then be: $\Delta p_k = (0,051 / 0,0217)^2 = 5.5 \text{ kPa}$.

The sound level is given in Table 4 and is 25 dB(A), which meets the max. permissible level of 27 dB(A) required.

Note that the specified sound level refers to the sound generated from the unit without consideration taken to possible sound generated by other sound sources such as commissioning dampers.

Heating

Waterborne heating

The method for the heating calculation is the same as for cooling. The heating capacity can be found in tables 14-17. The water flow is taken from diagram 3 and the pressure constant k_{pv} can be found in table 11.

Electric heating

For particulars of electric heating, see Table 13.

Conditions

The prerequisites are the same as in the example for cooling, with the exception that the design room temperature in the winter case is 22°C and the supply air temperature is 18°C . The heating load is estimated to be 45 W/m^2 which in the relevant room is recalculated to $4.2 \times 2.4 \times 45 = 454 \text{ W}$.

The inlet flow temperature of the heating water is 47°C and the return temperature is 37°C .

Solution

The 18°C supply air temperature and the 22°C room temperature provide $\Delta T_i = 4 \text{ K}$.

The reduction in heating water temperature = $47 - 37 = 10 \text{ K}$.

The mean temperature of the heating water is $(47 + 37) / 2 = 42^\circ\text{C}$.

The 42°C mean temperature of the heating water and the 22°C room temperature provide $\Delta T_{mv} = 20 \text{ K}$.

The supply air has a cooling effect which is calculated: $P_i = 1.2 \times 19 \times 4 = 91 \text{ W}$.

Since the supply air has a cooling effect, the total heating load must be recalculated: $454 + 91 = 545 \text{ W}$.

In Table 14, we read that a PARAGON WALL 900 NC with nozzle adjustment MM produces 615 W in heating capacity for 19 l/s supply airflow, 100 Pa nozzle pressure and $\Delta T_{mv} = 20 \text{ K}$. This is sufficient for managing the heating load.

From Diagram 3 we read a capacity of 615 W and a 10K decrease in heating water temperature as well as a water flow of approx. 0.015 l/s. By means of the water flow and the pressure drop constant k_{pk} which is taken from Table 11, the pressure drop across the coil will then be: $\Delta p_v = (0,015 / 0,0178)^2 = 0.7 \text{ kPa}$.

ProSelect

Planning and sizing based on given design considerations can also ideally be carried out in Swegon's ProSelect project design program.

ProSelect is available at Swegon's home page: www.swegon.com.

Sound

Natural attenuation

Natural attenuation is the total reduction in sound power from duct to room including the end reflection of the unit.

Table 18. Natural attenuation with lining

Natural attenuation (dB) for mid frequency f (Hz) ΔL_w [dB]							
63	125	250	500	1k	2k	4k	8k
24	14	9	6	9	14	14	18

Accessories

Supply air kit – PARAGON T-SAK-VAV

A motor-driven damper is needed in applications where the user wants to demand-control the supply air by means of CONDUCTOR control equipment. The damper causes a certain amount of flow-generated sound. Therefore a sound attenuator is also needed to guarantee a low sound level in the room. The following components are included in PARAGON T-SAK-VAV:

Motor-driven damper	CRTc including Belimo CM24, 2-10V
Sound attenuator	CLA rectangular sound attenuator with circular connection spigots L=500mm

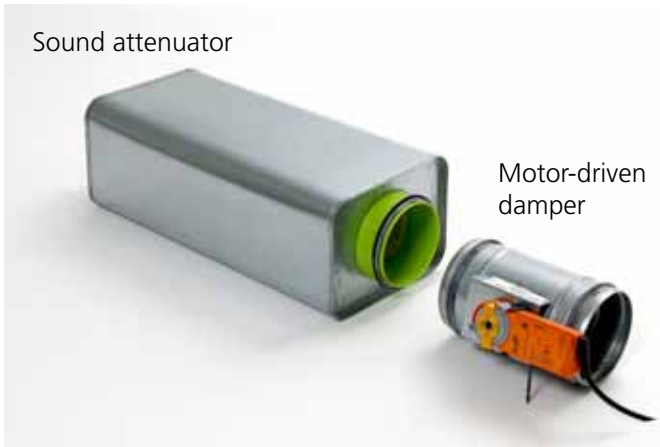

Figure 15. PARAGON T-SAK-VAV

Supply air kit – PARAGON T-SAK-CAV

A commissioning damper is needed to ensure the correct airflow if a simpler feed-back control system with constant airflow has been selected. Commissioning dampers also generate a certain amount of sound. We therefore recommend the use of a sound attenuator for keeping the sound level at a minimum. The following components are included in PARAGON T-SAK-CAV:

Commissioning damper	CRPc-9 Commissioning damper with perforated damper blade and manually adjustable blade
Sound attenuator	CLA rectangular sound attenuator with circular connection spigots L=500mm



Figure 16. PARAGON T-SAK-CAV

Extract air kit – PARAGON T-EAK-VAV

If the supply air is demand-controlled, the extract air also needs to be feed-back controlled. An extract air kit is needed for balancing the supply air and the extract air. Precisely like the supply air kit, this kit consists of a motor-driven damper and a sound attenuator. In addition an extract air register and two alternative mounting frames are included: one with a nipple and one with a joint.

Motor-driven damper	CRTc including Belimo CM24, 2-10V
Sound attenuator	CLA rectangular sound attenuator with circular connection spigots L=500mm
Extract air register	EXCa and accompanying mounting frames: one with a nipple and one with a joint



Figure 17. Extract air kit, PARAGON T-EAK-VAV

Extract air kit – PARAGON T-EAK-CAV

A commissioning damper is needed in systems with constant airflows in order to balance the extract airflow with the supply airflow.

For simpler systems, a kit designed for constant airflow is available. This kit contains commissioning damper, sound attenuator, extract air register and mounting frames.

Commissioning damper	CRPc-9 Commissioning damper with perforated damper blade and manually adjustable blade
Sound attenuator	CLA rectangular sound attenuator with circular connection spigots L=500mm
Extract air register	EXCa and accompanying mounting frames: One with a nipple and one with a joint

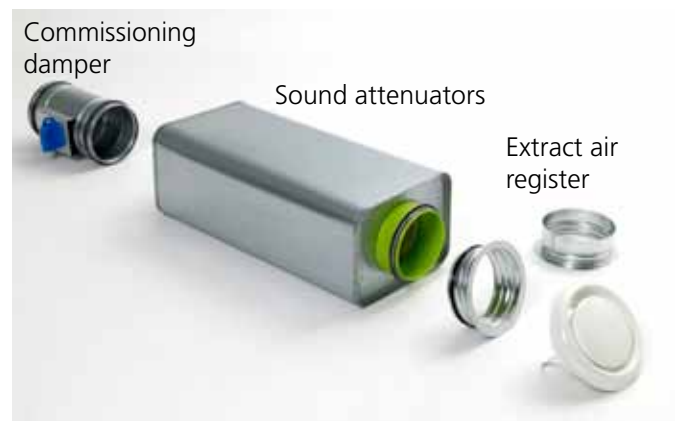

Figure 18. Extract air kit - PARAGON T-EAK-CAV

SYST MS M8 suspension kit

In the applications in which the Paragon Wall is not mounted in direct contact with the ceiling, a suspension kit is available which simplifies the task of lowering it to hang at the level desired.

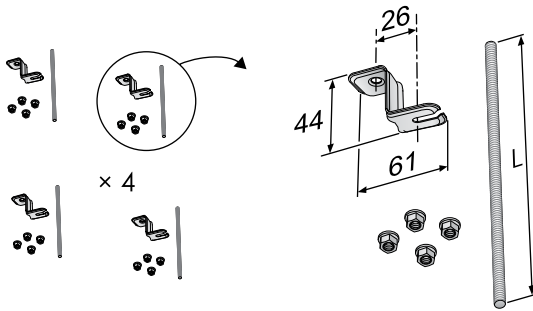

Figure 19. Suspension kit, SYST MS M8

Venting nipple

A venting nipple with push-on connection can be utilised in combination with type SYST FS F20 flexible hoses. This is normally not needed, but can be an option if the coil in the paragon Wall is at the highest point on the water loop.

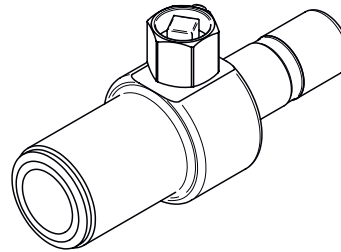

Figure 21. Venting nipple, SYST AR

Flexible hoses

In applications in which you desire to avoid risk of movement in the pipe system caused by heat expansion, you can advantageously utilize flexible hoses for the connection of chilled water and hot water. Eventual vibrations via the pipe system are at the same time diminished to an absolute minimum.

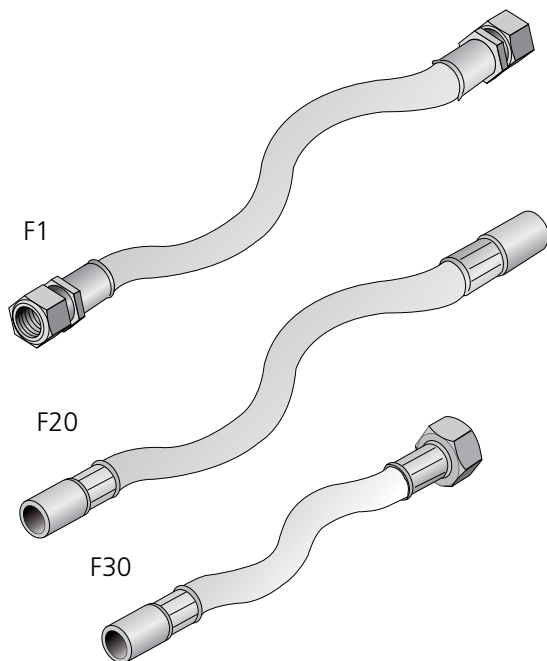

Figure 20. Flexible connection hoses, SYST FH

Installation

Assembly

The Paragon Wall is delivered with two mounting brackets designed for installation directly against the ceiling. By loosening the mounting brackets from the unit, they can be easily fastened to the ceiling beams with approximate distance to the desired final position of the outlet grille. Then lift the Paragon Wall unit and push it into the mounting brackets. When you have precision-adjusted the unit to the correct position, lock the mounting brackets to totally secure the unit is fixed position. The next step is to connect the air duct, cooling pipes, heating pipes and power supply (24 V AC) to the control equipment. The motor dampers can be directly wired into the controller in the Paragon Wall, if a supply air kit and an extract air kit are included in the installation. The SYST MS suspension kit (must be ordered separately) can preferably be used in cases when the Paragon Wall should not be mounted directly against the ceiling. For detailed mounting instruction see separate document available for downloading at www.swegon.com.

Water connections

If the Paragon Wall is supplied with factory-fitted control equipment, the supply water (cooling and heating) should be connected to Ø 12 x 1.0 mm (Cu) flat pipe end. The return water (cooling and heating) should be connected to the valves, DN ½" male threads.

If the Paragon Wall is supplied without control equipment, all the pipes (supply/return – cooling/heating) should be connected to Ø 12 x 1.0 mm (Cu) flat pipe end.

N.B.! Support sleeves must be used if compression ring couplings are fitted. It is important use a pipe wrench to adequately restrain the pipe connections when tightening external connections to prevent damage to the connection pipes.

Air connection

A Ø 125 mm air duct including gasket should be connected directly to a fixed nipple.

If the supply air kit is included in the installation, connect the parts in the following order, viewed from the Paragon Wall:

1. PARAGON WALL Comfort module
2. Air duct, Ø 125 mm
3. Sound attenuator, CLA
4. Air duct, Ø 125 mm
5. CRT motor-driven damper

Note that the supply and extract air kits are also available for 100 dia. conn. This kit is suitable for use if the space is limited and low airflows are discharged into the room.

To connect the feed-back control equipment

CONDUCTOR

If the CONDUCTOR control equipment is supplied in factory-fitted condition, the actuator (cooling and heating) is wired to the controller on delivery. The controller must be energized in order to start up the feed-back control functions. This occurs either through the supply of power via a 24 V AC network or through the addition of a separate transformer.

The transformer is available as accessory and must be ordered separately. Note that a transformer normally supplies enough current to operate up to 6 controllers. This assumes that the Paragon Wall units with factory-fitted mounted CONDUCTOR are situated within a reasonable distance, to avoid too drastic voltage drops in the cables.

The room controller is delivered well packaged together with the Paragon Wall. The room controller can either operate with wireless remote control or have a wired cable connection. If the controller operates through wireless communication, 4 size AAA batteries supply it with power. If cable connection is used, the room unit is supplied with power via the same cabling used for communication between the module controller and the room controller. As soon as the module controller and the room controller are energized, you simply enter the ID number of the module controller into the room controller to start wireless communication. If the room controller is connected via a cable, you are not required to enter any ID number.

There are several accessories available to special order for utilising the energy saving functions available in the CONDUCTOR with application W4.1 (standard). The motor operated dampers can be easily wired directly to the controller, if the supply and extract air kits are included in the installation.

For hotels there is provision for connecting a key card holder intended to serve as a presence sensor. Of course traditional presence sensors can also be connected, if they are required. There is also an input for a window contact (not accessory), which can be utilized for saving energy when the window is opened. For more information regarding CONDUCTOR W4.1, see the separate product data sheet.

LUNA

If the Paragon Wall is equipped with LUNA factory-fitted control equipment, the actuator (cooling and heating) is wired to a terminal block, which is simple to reach after dismantling the recirculation grille in the bottom side of the Paragon Wall. There is no controller mounted in the Paragon Wall, since the intelligence in the LUNA is integrated into the room controller. The controller is then instead delivered separately well packaged together with the Paragon Wall. The controller must be energized before it can be started up. This is done either by supplying 24 V AC from a network or through the addition of a separate transformer.

The transformer is available as accessory and must be ordered separately. Note that a transformer normally supplies enough current to operate up to 6 controllers. This assumes that the Paragon Wall units with factory-fitted mounted LUNA are situated within a reasonable distance, to avoid too drastic voltage drops.

Maintenance

Since the Paragon Wall operates without any built-in fan, without filter and without a drainage system, very little maintenance is required. In a hotel room or a hospital ward, it is normally sufficient to vacuum clean the back side of the coil every six months to remove loose dust. A simple visual inspection of connections and wiping the supply air grille and the condensate drip tray with a damp cloth is also recommended. Avoid aggressive cleaning agents which may harm painted surfaces. Normally a mild soap or alcohol solution is fully adequate for cleaning. Note that the dry operation without condensation minimises the risk of bacteria growth that otherwise occurs in wet systems.

The requirement for maintenance is yet lower in an office room, since this type of environment is normally much more dust-free, and this allows longer intervals between scheduled maintenance. It is normally enough to clean the coil in an office room once every second year.

To wire the electric heating elements

Swegon's LUNA or your own control system can be used for controlling the heating elements in the electric variant of the Paragon Wall.

Information about how to wire the control system is provided in a separate product data sheet and installation instructions at www.swegon.com

CE marking

The Paragon Wall with electric heating is CE marked in accordance with applicable regulations.

The CE Declaration is available at our home page: www.swegon.com

Dimensions and Weights

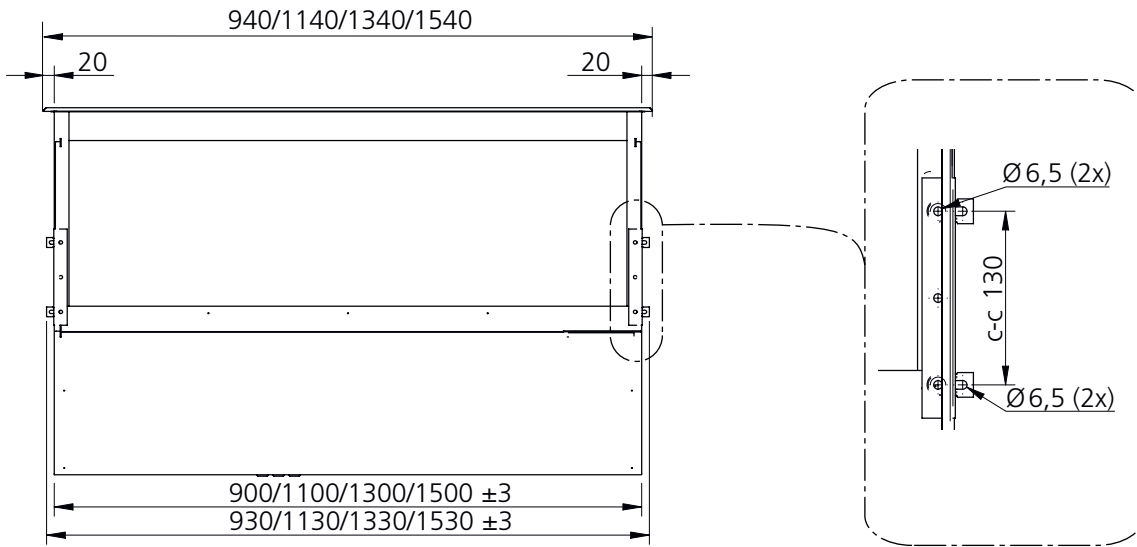

Figure 22. View seen from above

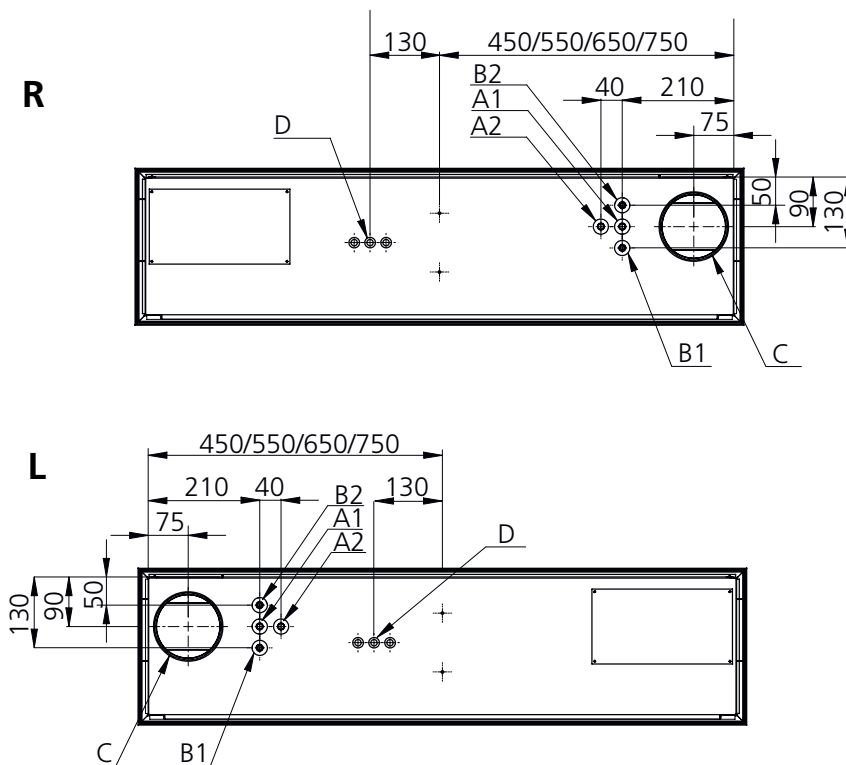

Figure 23. View of the backside, connections
L = left-hand connection; R = right-hand connection

- A1 = Cooling water, inlet Ø12x1.0 mm (Cu)
- A2 = Cooling water, return Ø12x1.0 mm (Cu).
- A1 = Heating water, inlet Ø12x1.0 mm (Cu)
- A2 = Heating water, return Ø12x1.0 mm (Cu).
- C = Connection piece for primary air, Ø125 mm
- D = Cable grommets, 3x

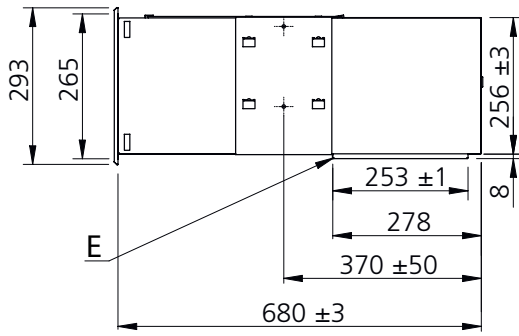

Figure 24. Viewed from end panel

E = Condensate drip tray

Table 19 - Weight - Variant B

NC L	Dry kg	Water volume cooling, litres	Water volume heating, litres
900	24.6	0.7	0.22
1100	28.3	0.8	0.28
1300	32.1	0.95	0.34
1500	35.8	1.1	0.40
HC L	Dry kg	Water volume cooling, litres	Water volume heating, litres
900	25.7	1.0	0.22
1100	29.6	1.2	0.28
1300	33.5	1.4	0.34
1500	37.4	1.6	0.40

Weight = without grills

Table 20 - Weight - Variant X

NC L	Dry kg	Water volume cooling, litres
900	25.2	0,7
1100	29	0,8
1300	32,9	0,95
1500	36,5	1,1
HC L	Dry kg	Water volume cooling, litres
900	26,3	1,0
1100	30,3	1,2
1300	34,3	1,4
1500	38,2	1,6

Weight = without grills

Dimensions, accessories

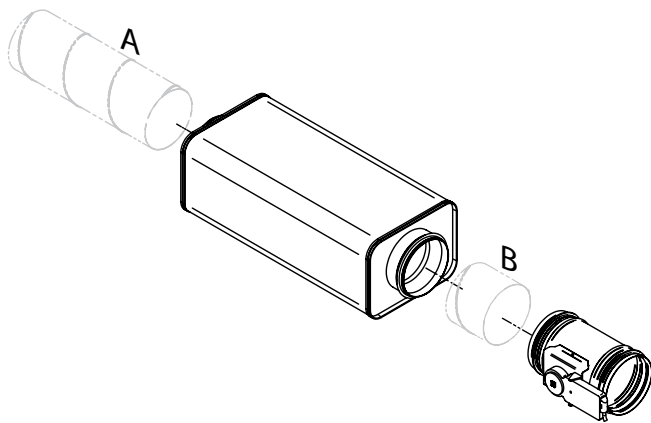

Figure 25. Supply air kit, PARAGON T-SAK-VAV-125
Spiral ducts are not included.
Spiral duct A: Min. length: 330mm
Spiral duct B: Min. length: 70mm

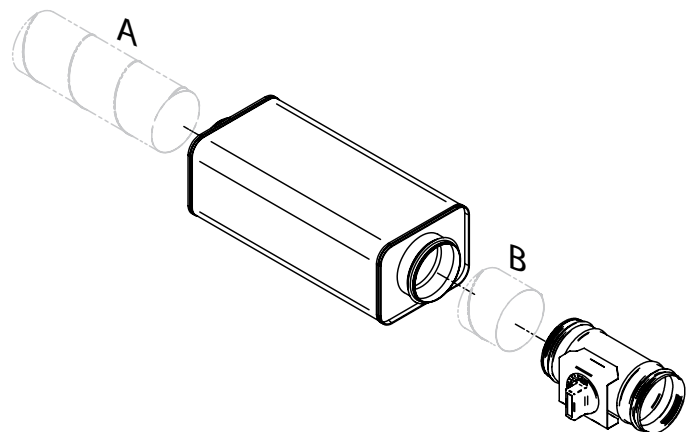

Figure 27. Supply air kit, PARAGON T-SAK-CAV-125
Spiral ducts are not included.
Spiral duct A: Min. length: 330mm
Spiral duct B: Min. length: 70mm

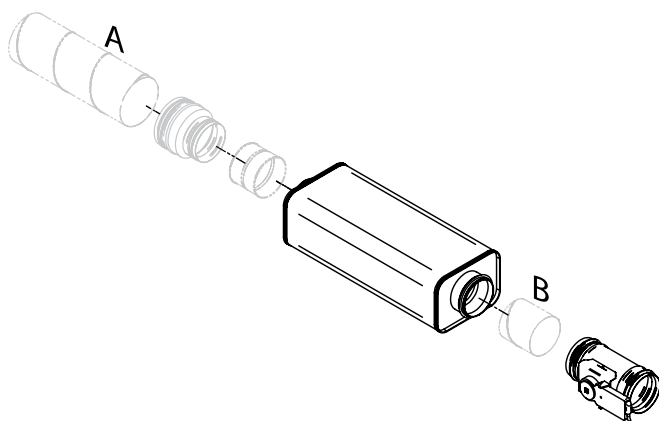

Figure 26. Supply air kit, PARAGON T-SAK-VAV-100
Size 100 spiral ducts and jointing sleeves are not included.
Spiral duct A: Min. length: 330mm
Spiral duct B: Min. length: 70mm

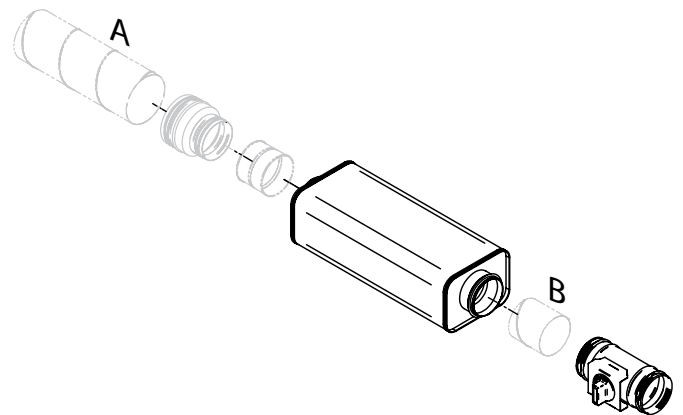

Figure 28. Supply air kit, PARAGON T-SAK-CAV-100
Size 100 spiral ducts and jointing sleeves are not included.
Spiral duct A: Min. length: 330mm
Spiral duct B: Min. length: 70mm

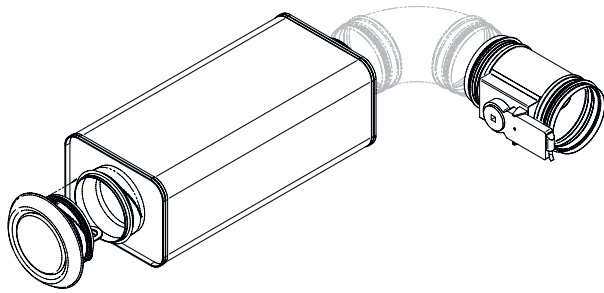

Figure 29. Extract air kit, PARAGON T-EAK

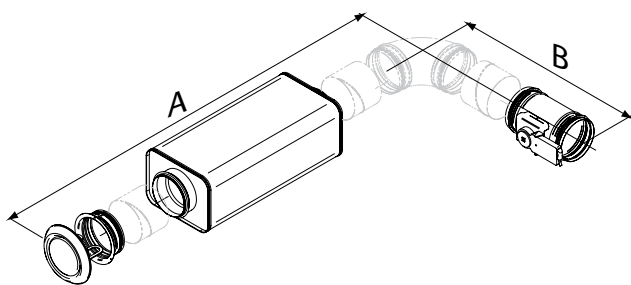

Figure 30. Extract air kit, PARAGON T-EAK-VAV
 Available for connection sizes 125 and 100.
 Spiral ducts and ends are not included
 A: Min. length: 770mm
 B: Min. length: 360mm

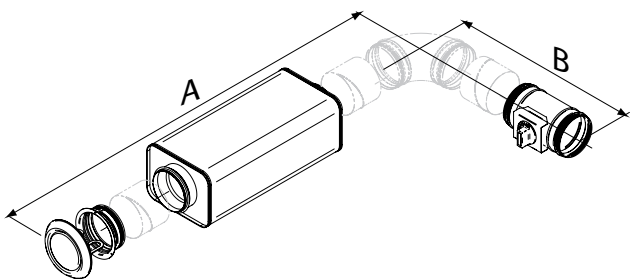

Figure 31. Extract air kit, PARAGON T-EAK-CAV
 Available for connection sizes 125 and 100.
 Spiral ducts and bends are not included
 A: Min. length: 770mm
 B: Min. length: 360mm

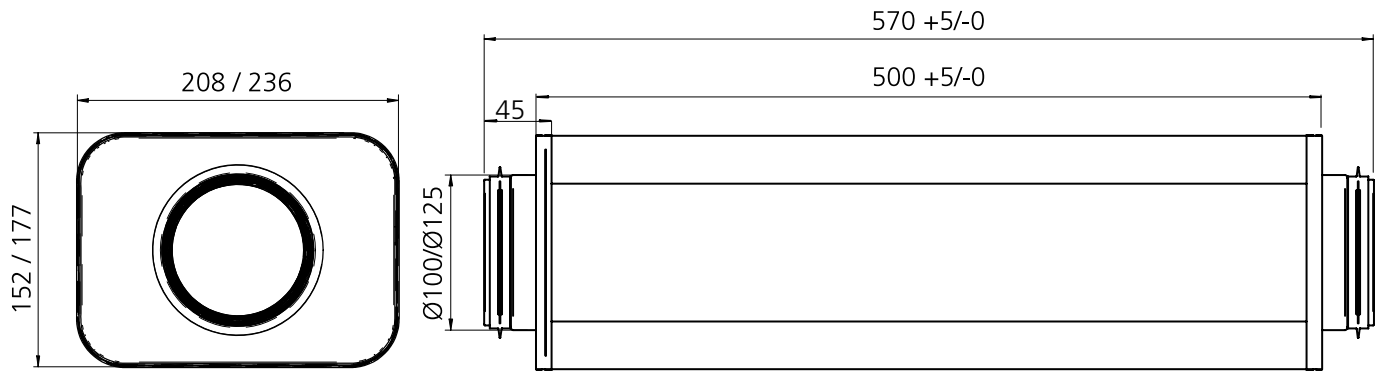

Figure 32. Dimension print, CLA sound attenuator Ø100-500 or Ø125-500. Included in PARAGON T-SAK and PARAGON T-EAK:

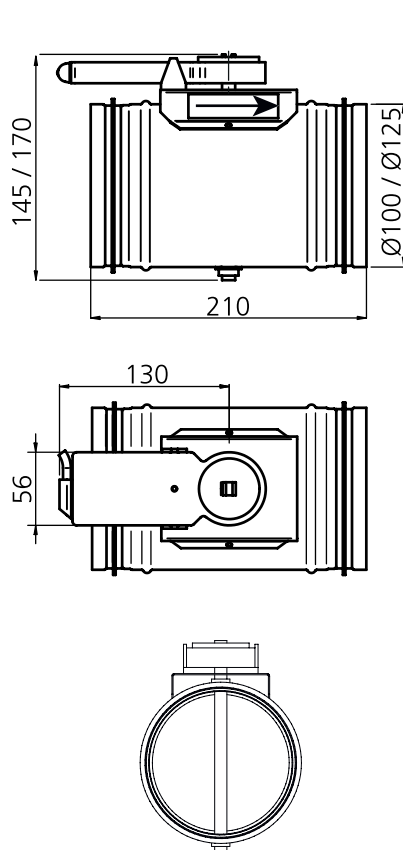

Figure 33. Dimension print, motor-driven damper. Included in PARAGON T-SAK-VAV and PARAGON T-EAK-VAV:

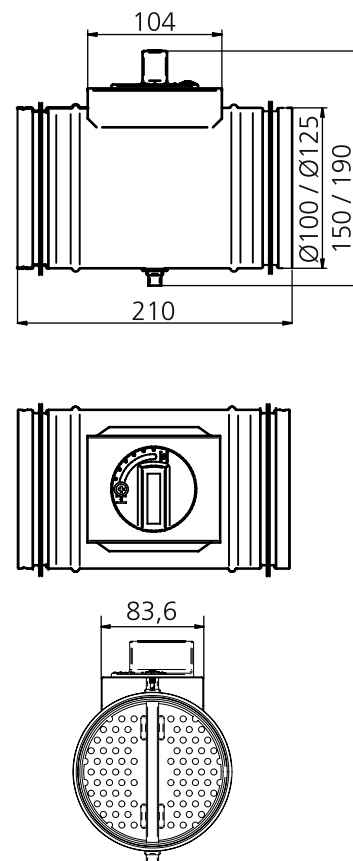

Figure 34. Dimension print, commissioning damper. Included in PARAGON T-SAK-CAV and PARAGON T-EAK-CAV:

Factory-fitted control equipment

Optional: Orders can be placed for factory-fitted control equipment for the Paragon Wall.

See in the table below what is included in the various control system kits available for Paragon and Paragon Wall.

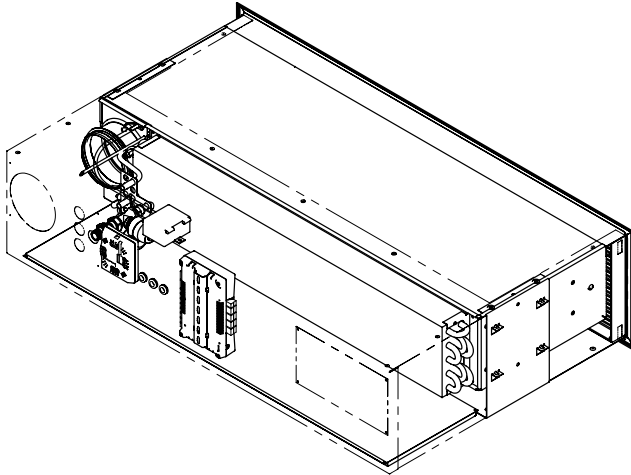

Figure 35. PARAGON T-COND-W4.1-CH

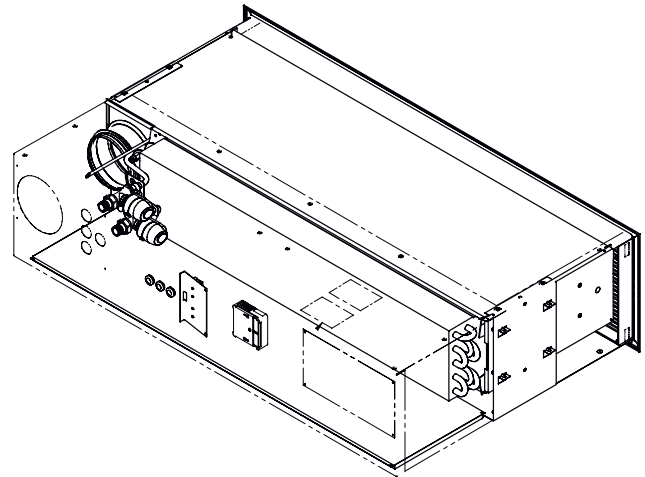

Figure 36. PARAGON T-LUNA-CH

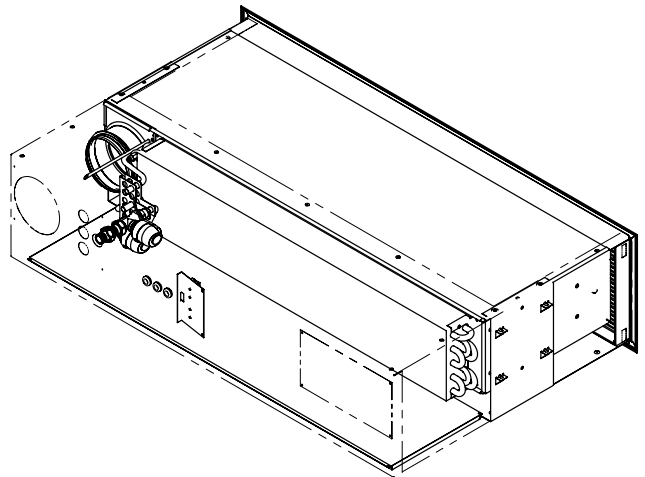

Figure 37. PARAGON T-COND-SLAVE-CH

Table 21. The components included in the control system kit that is available for the Paragon Wall

Designation	Valve	Actuator	Terminal block	Module Controller				Room controller	Pressure Sensor
				W1	W3	W4.1	RE-S	RU	
PARAGON T-									
" " COND-W3-CH	2	2			1			1	
" " COND-W1-CH	2	2		1				1	
" " COND-W4.1-CH	2	2				1		1	1
" " COND-SLAVE-CH	2	2	2						
" " LUNA-CH	2	2	2				1		
" " COND-W3-C	1	1			1			1	
" " COND-W1-C	1	1		1				1	
" " COND-W4.1-C	1	1				1		1	1
" " COND-SLAVE-C	1	1	2						
" " LUNA-C	1	1	2				1		

Ordering key

PARAGON WALL Ordering key

Type PARAGON WALL comfort module for cooling, heating, ventilation and control. As standard, factory assembled components are included for plug & play installation.

PARAGON WALL delivery demarcation

Swegon's limits of supply are at the connection points for water.

At these connection points, the RE pipework contractor connects to plain pipe end and/or male threads towards valves, fills the system, bleeds it and tests the pressure in the circuits.

The ventilation contractor connects to the duct connections with dimensions as specified on the basic size drawing in the section "Dimensions".

EE electrical equipment contractor provides a 24 V AC network power supply or earthed 230 V outlets for a transformer, as well as a junction box, if required, installed in a wall for a room thermostat.

The building contractor cuts the openings in corridor wall for the supply air duct, in the interior wall and suspended ceiling for the supply air and extract air grilles and in the bathroom ceiling for the extract air duct.

The electrical installation contractor connects the power (24 V) and the signal cables to the wiring terminals equipped with spring-loaded pressure connections. The maximum permissible cable cross-sectional area is 2.5 mm².

For reliable operation we recommend the use of cable ends with multi-pin connectors.

For particulars on how to wire the electric heating, see the separate installation instructions at www.swegon.com

PARAGON WALL Ordering key

PARAGON WALL	a-	bbbb-	c-	dd-	e-	fg
Version:						
Length (mm) 900, 1100, 1300 and 1500						
Function: B = Cooling and heating X = Cooling and electric heating						
Capacity variant NC – Normal version HC – High capacity version						
Connection side R - Right-hand L - Left-hand						
Flow variant Upper nozzle row: L, M, H Lower nozzle row: L, M, H						

Factory-fitted controls kit, optional

Control equipment, PARAGON factory fitted	a-	T-COND-	bbbb-	cc
Version:				
CONDUCTOR W1, W3, W4.1 or SLAVE				
C = Cooling CH = Cooling and heating				

Control equipment, PARAGON factory fitted	a-	T-LUNA-	bb
Version:			
LUNA C = Cooling CH = Cooling and heating			

Example 1:

The PARAGON without control equipment:

PARAGON WALL a-1100-B-NC-R-LM

Example 2:

The PARAGON WALL with left-hand connecton and CONDUCTOR W4.1 factory-fitted control equipment for cooling and waterborne heating

PARAGON WALL a-1300-B-HC-L-MH
PARAGON a-T-COND-W4.1-CH

Available to order, kit and accessories

Supply air kit	VAV: PARAGON CRTc motor-driven damper with tight damper blade with damper actuator and CLA sound attenuator
	CAV: PARAGON CRPc manually adjustable damper with perforated damper blade with damper actuator and CLA sound attenuator
Extract air kit	VAV: PARAGON CRTc motor-driven damper with tight damper blade with damper actuator, CLA sound attenuator and extract air register with mounting frame
	CAV: PARAGON CRPc manually adjustable damper with perforated damper blade with damper actuator, CLA sound attenuator and extract air register with mounting frame
Flexible connection hose	Connection hose is supplied with clamping ring coupling, push-on coupling or sleeve nut.
Assembly piece	Ceiling mounting bracket and threaded rod for mounting in ceiling. Double threaded rods with thread lock are also available.
Venting nipple	Venting nipple with push-on coupling for connection to the return pipe for water, diameter: 12 mm
For further accessories for the control equipment, see the CONDUCTOR and LUNA product datasheets.	

Factory-fitted accessory kit

Supply air kit	PARAGON	a-	T-SAK-VAV-	bbb
Version:				
Kit with motor-driven damper				
Ø100; Ø125				

Supply air kit	PARAGON	a-	T-SAK-CAV-	bbb
Version:				
Kit with manually adjustable damper				
Ø100; Ø125				

Extract air kit	PARAGON	a-	T-EAK-VAV-	bbb
Version:				
Kit with motor-driven damper				
Ø100; Ø125				

Extract air kit	PARAGON	a-	T-EAK-CAV-	bbb
Version:				
Kit with manually adjustable damper				
Ø100; Ø125				

Ordering Key, Accessories

Assembly piece	SYST MS M8-	aaaa-	b
Length of threaded rod (mm): 200; 500; 1000			
Type: 1=One threaded rod 2=Two threaded rods and a thread lock			

Flexible connection hose, (1 piece)	SYST FH F1-	aaa-	12
Compression ring (Ø12 mm) against pipe in both ends (excl. support sleeves)			
Length (mm): 300; 500; 700			

Flexible connection hose, (1 piece)	SYST FH F20-	aaa-	12
Quick-fit push-on coupling (Ø12 mm) against pipe in both ends			
Length (mm): 275; 475; 675			

Flexible connection hose, (1 piece)	SYST FH F30-	aaa-	12
Quick-fit push-on coupling (Ø12 mm) against pipe in one end, sleeve nut G20ID in the other end.			
Length (mm): 200; 400; 600			

Venting nipple

SYST AR12

Specification text

Example of a specification text conforming to VVS AMA Standard.

KB XX

Swegon's PARAGON WALL comfort module that supplies air via a common supply air and recirculated air grille.

For rear edge installation in a wall or ceiling, with the following functions:

- Cooling
- Heating, (water or electric)
- Ventilation
- VariFlow for simple adjustment of the airflows
- ADC
- 125 mm dia. duct connection
- Built-in recirculating air opening
- Coil and control equipment, if required, accessible via an inspection cover
- Cleanable
- Fixed measurement tapping with tube
- Supply air and recirculating air grille painted in standard shade of white (RAL 9003)
- Contractor demarcation at the connection points for water and air according to the outline drawing
- At the connection points, the pipe contractor connects the piping to 12 mm plain pipe ends; then the ventilation contractor connects the ducting to the 25 mm dia. insertion joint(s).
- The pipework contractor fills, bleeds, tests the pressure and assumes responsibility for the design water flows reaching each branch of the system and the climate beam.
- The ventilation contractor conducts initial commissioning of the airflows.

Factory-fitted controls kit:

- PARAGON a-T-COND-bbbbb-cc xx items
- PARAGON a-T-LUNA-bb xx items

Factory-fitted accessory kit:

- PARAGON a-T-SAK-VAV-bbb xx items
- PARAGON a-T-SAK-CAV-bbb xx items
- PARAGON a-T-EAK-VAV-bbb xx items
- PARAGON a-T-EAK-CAV-bbb xx items

Accessories:

- Commissioning damper, SYST CPRc 9-125, xx items.
 - Assembly piece SYST MS M8 aaaa-b
 - Flexible connection hose, SYST FH F1 aaa - 12 xx items
 - Flexible connection hose, SYST FH F20 aaa- 12 xx items
 - Flexible connection hose, SYST FH F30 aaa- 12 xx items
 - Venting nipple, SYST AR 12 xx items
- etc.

Specify the quantity separately or with reference to the drawing.

Size:

KB XX-1 PARAGON WALL a-bbbb-c-dd-e-fg with factory-fitted control equipment

PARAGON a-T-COND-bbbbb-cc xx items

KB XX-2 PARAGON WALL a-bbbb-c-dd-e-fg xx items

etc.