

Swegon PACIFIC®



Integrated climate beam

www.eurovent-certification.com
www.certiflash.com



PACIFIC

PACIFIC climate beam

- ▶ The PACIFIC is a high performance climate beam for installation in false ceilings.
- ▶ With high built-in flexibility, it is designed to meet today's needs as well as those of tomorrow.
- ▶ The modular design offers great freedom of choice for configuring its arrangement to meet current needs.
- ▶ Supply air, cooling and heating
- ▶ Supply air, cooling and electric heating
- ▶ Additional SA/EA module with extra supply air (SA) and extract air (EA) in the same face plate as the PACIFIC.

Key figures

Primary airflow, PACIFIC:	Up to 75 l/s
Pressure range:	30 to 150 Pa
Cooling capacity, PACIFIC:	Up to 3400 W
Heating capacity, PACIFIC:	Water: Up to 3500 W Electric: Up to 1000 W
Lengths:	1200/1800/2400/3000 mm*
Widths:	Min. 594 mm / max. 667 mm*
*The PACIFIC is obtainable in lengths and widths that fit the majority of false ceilings available on the market. [See page 15].	
Heights, Ø100/125/160:	163 mm; 189 mm; 277 mm
Additional SA/EA module	
SA, Supply airflow:	Up to 65 l/s
SA, Cooling capacity:	Up to 470 W
EA, Extract airflow:	max. 100 l/s



Figure 1. PACIFIC

Operation

The PACIFIC is an active climate beam with two-way air distribution. The unit does not contain a fan of its own but instead is driven by the pressure and flow generated by a centrally located air handling unit, which means low sound level and excellent comfort in the room.

The PACIFIC is designed for dry systems, i.e. without condensation and therefore does not require any condensate drainage system or any filter. The minimum number of moving parts and lack of filter guarantees very little need for maintenance.



Figure 2. Standard PACIFIC climate beam.

Additional SA/EA module

A standard PACIFIC can also be equipped with an additional SA/EA module which is an integrated supply air and extract air module.

The SA/EA module can also be supplemented with various types of accessory packages designed for obtaining different functions.



Figure 3. Pacific with additional SA/EA module

Flexibility

The modular design and the built-in commissioning functions make the PACIFIC adaptable to meet current needs in all phases of its useful product life.

- In the planning phase of the project: adapt the performance and the physical dimensions to suit the current project.
- In the installation phase: commission the airflow volume, distribution and direction to provide optimum comfort.
- In the operating phase: adjust the airflow volume, distribution and direction to deal with changes in e.g. the layout of the building.

Induction principle

The PACIFIC climate beam operates according to the induction principle. A centrally located air handling unit distributes primary air via the duct system into the plenum of the unit and creates excess pressure. The plenum is equipped with a number of sliding strips with nozzles for variation of the air volume. The excess pressure in the plenum forces the primary air through the nozzles at relatively high velocity. When the primary air is distributed at high velocity through the nozzles, negative pressure is created in the space above the built-in heat exchanger (coil). The negative pressure sucks (induces) the room air up through the heat exchanger where the air is treated as required.

If cooling is required, the room control equipment opens the cooling circuit valve and chilled water circulates through the cooling circuit of the heat exchanger. The recirculating air is chilled and is mixed with the primary air before it is discharged into the room.

If heating is required, the heating circuit valve opens instead and hot water circulates in the heat exchanger and the recirculating air is heated before it is mixed with the primary air and is discharged into the room.

The PACIFIC can also be equipped with electric heating if desired. The electric heat is then generated by heating rods that have been inserted into the heating tubes of the heat exchanger. The induction principle is still the same as that with waterborne heating however instead of opening a valve, the heating rods are energised.

If neither cooling nor heating is required, then the recirculating air passes through the heat exchanger without being treated. The ratio between the primary air and the recirculating air varies depending on the magnitude of the excess pressure and the airflow rate of the primary air. This relationship is also called the degree of induction.

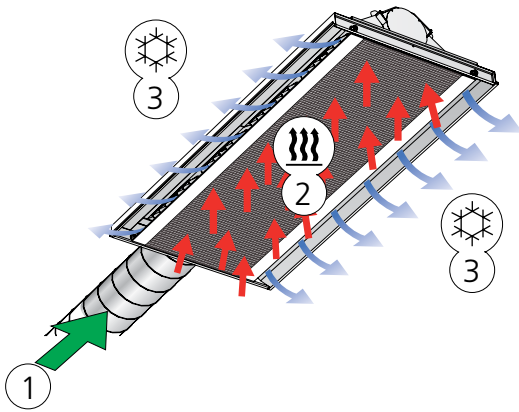

Figure 4. Cooling operation

- 1 = Primary air
- 2 = Induced room air
- 3 = Primary air mixed with chilled room air

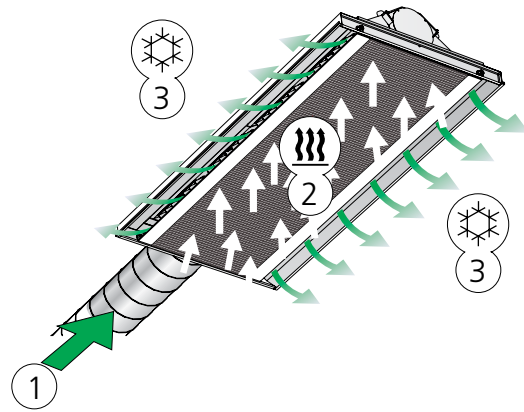

Figure 6. Neutral operation

- 1 = Primary air
- 2 = Induced room air
- 3 = Primary air mixed with untreated room air

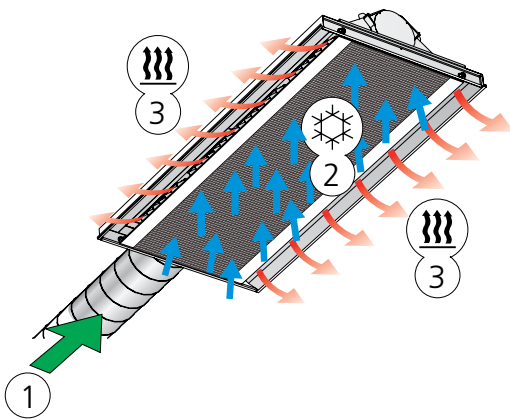

Figure 5. Heating operation

- 1 = Primary air
- 2 = Induced room air
- 3 = Primary air mixed with heated room air

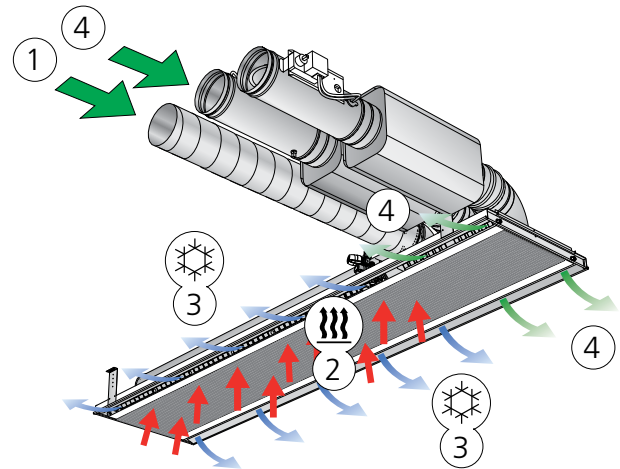

Figure 7. Cooling function for the Pacific SAIEA

- 1 = Primary air
- 2 = Induced room air
- 3 = Primary air mixed with chilled room air
- 4 = Extra supply air

Range of Application

- Offices and conference rooms
- Classrooms
- Hotels
- Restaurants
- Hospitals
- Shops
- Shopping centres

Security

The PACIFIC is certified by Eurovent. This guarantees that all specified performance data has been tested and validated.

Capacity we take responsibility for

The PACIFIC has been developed for generating high cooling and heating capacity without compromising comfort. The outlet of the unit is designed to handle large pressure and flow ranges with maintained Coanda effect. The result is that the distributed air is kept near the ceiling, has time to mix with the room air and its velocity decreases before it reaches the occupied zone. This provides an excellent indoor climate with low air velocities.

Flexibility

Modern office buildings make ever stricter demands on adaptability to various needs. A layout that from the beginning was designed as an open-plan office may in the next phase need to be partitioned into smaller rooms. By carefully planning the cooling, heating and ventilation installations from the beginning, the costs for future operational changes or needs can be drastically reduced. The PACIFIC is a climate beam developed for maximum flexibility throughout its useful life.

Since different buildings involve different demands on performance as well as physical measurements, the design of the PACIFIC enables it to be configured to suit the needs of your application. The unit is divided into two modules: Capacity module and Design module

The capacity module contains a combined cooling and heating coil with two separate water circuits, one for cooling and the other for heating. The capacity modules come in four different lengths to choose from: If you select the SA/EA additional module, you can choose between capacity modules in three optional lengths. The length required is determined by capacity and flexibility needs.



Figure 8. Capacity module.

There are three different primary air connection sizes to choose from, depending on what airflow and sound requirements have to be met: Ø100; Ø125 and Ø160 mm. The size of the air connection determines the height of the unit which means that you must take into consideration the available space above the false ceiling.

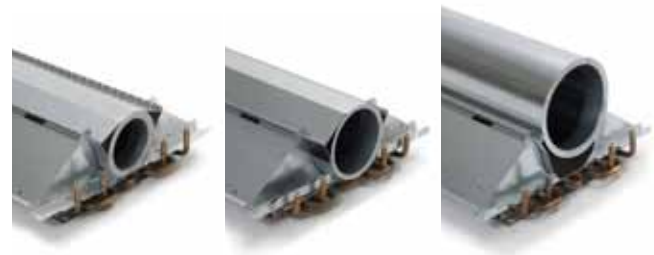

Figure 9. Capacity module - Ø100; Ø125 and Ø160 mm

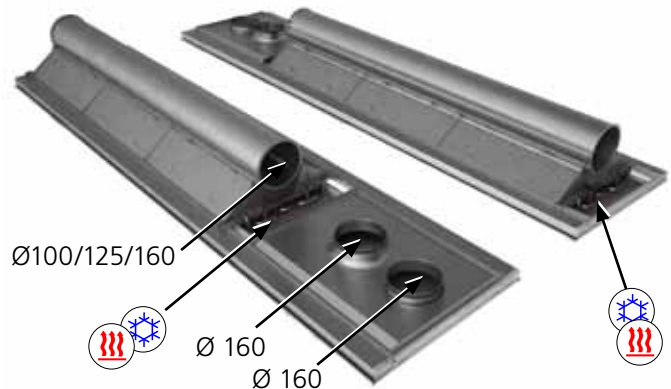







Figure 10. PACIFIC SA/EA with capacity module and additional SA/EA - Ø160 mm, two options for connection points for cooling and heating pipes.

Additional SA/EA module and accessory package

The additional SA/EA module is an accessory for installation and integration into the PACIFIC climate beam.

The module has two 160mm dia. connections, one for extra supply air and one for extract air.

The functions obtainable in a PACIFIC SA/EA are the following:

	Cooling
	Heating
	Supply air, cooled or heated via the capacity module
	Extra supply air via the SA/EA module
	Extract air via the SA/EA module

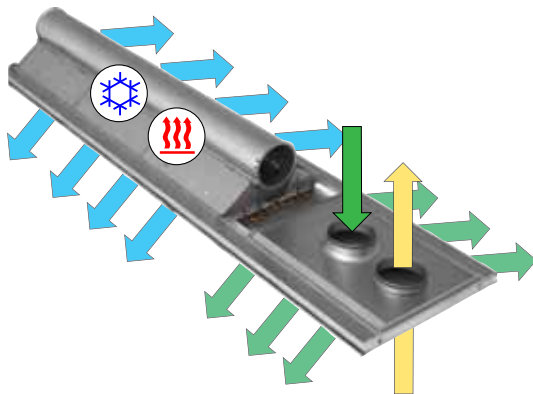

Figure 11. Functions in the Pacific SA/EA

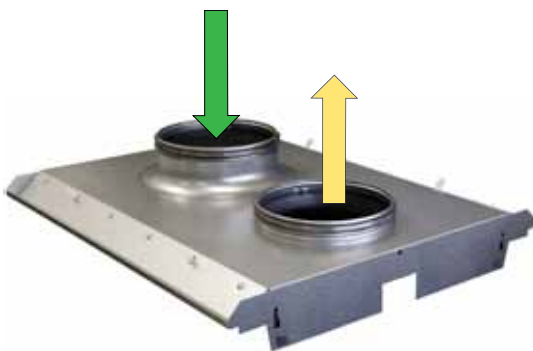

Figure 12. Additional SA/EA module

The PACIFIC SA/EA can be supplied with connection pipes for cooling and heating located between the capacity module and the SA/EA module or on the short side of the product.

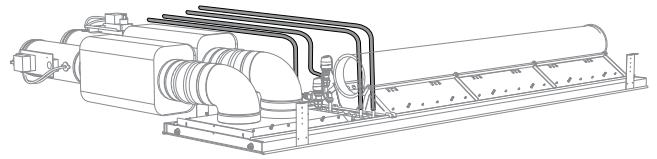

Figure 13. Pacific SA/EA with water pipes connected between the capacity module and the SA/EA module.

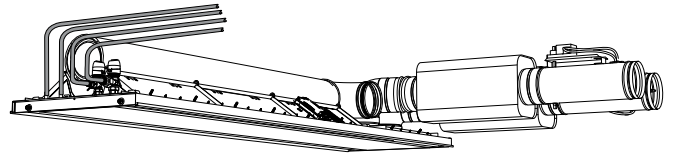

Figure 14. Pacific SA/EA with water pipes connected to the short side.

Accessory packages

The PACIFIC and SA/EA module have been developed to provide optimum performance and comfort in the room. To further tailor the climate beams to meet your ventilation needs, the products can be supplemented with a number of accessory kits.

T-AIR KIT CAV

This accessory kit can be used and you want extra supply air delivered to the room via the SA/EA module.

The kit contains one manual flow-adjusting damper for constant airflow, sound attenuator, connecting sleeves and duct bend.

Technical data such as e.g. airflow and sound level can be obtained in ProSelect.

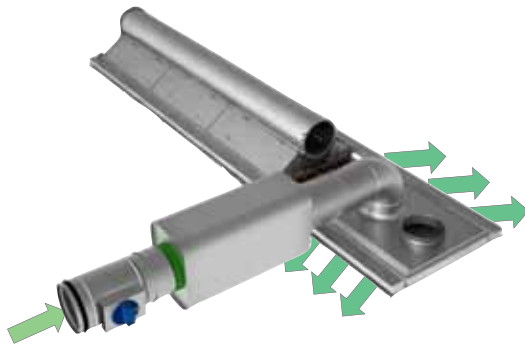

Figure 15. PACIFIC with extra supply air via T-AIR KIT CAV

The same accessory kit is suitable for use when you want an integrated extract air solution with constant extract airflow. The parts are then installed on the SA/EA module's connection for extract air.



Figure 16. PACIFIC with extract air via T-AIR KIT CAV

Two T-AIR KIT CAV are suitable for use when you want an integrated solution with extra supply air and extract air with constant airflows. The parts are then installed on the SA/EA module's connection for both supply air and extract air.

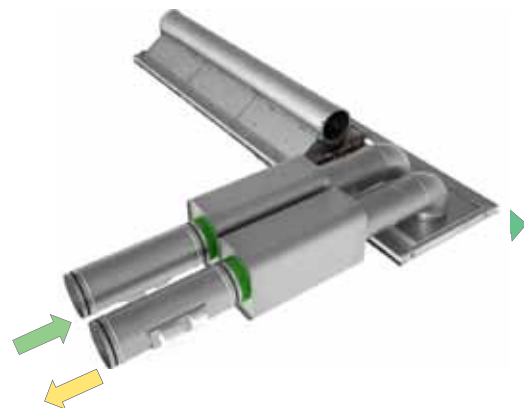

Figure 17. PACIFIC with extra supply air and extract air via T-AIR KIT CAV

T-AIR KIT VAV

This accessory kit in combination with the URC1 controller can be used and you want extra supply air via the SA/EA module when the room is occupied.

When the room is unoccupied, the climate beam delivers a constant airflow (the airflow is dependent on duct pressure, the size of the product and the nozzle configuration).

When the room is occupied, the motor-driven dampers open and the climate beam delivers extra supply air to the room according to the preset airflow on the motor-driven damper.

The kit contains one motor-driven damper with adjustable airflows, sound attenuator, connecting sleeves and duct bend.

Technical data such as e.g. airflow and sound level can be obtained in ProSelect.

N.B.! The URC1 controller is not included in the kit and must therefore be selected as a pre-fitted accessory on the climate beam.



Figure 18. PACIFIC with extra supply air via AIR KIT VAV

Two T-AIR KIT VAV can be used when you want an integrated solution with extra supply air and extract air with different airflows for non occupancy and occupancy in the room. The parts are then installed on the SA/EA module's connection for both supply air and extract air.

When the room is unoccupied, the climate beam delivers a constant airflow and the extract air leaves the room at the same airflow rate.

When there are occupants in the room, the airflows delivered to the room increase according to the value preset on the motor-driven damper for extra supply air and the extract airflow simultaneously increases to match both the supply airflows.

Technical data such as e.g. airflow and sound level can be obtained in ProSelect.

N.B.! The URC1 controller is not included in the kit and must therefore be selected as a pre-fitted accessory on the climate beam.

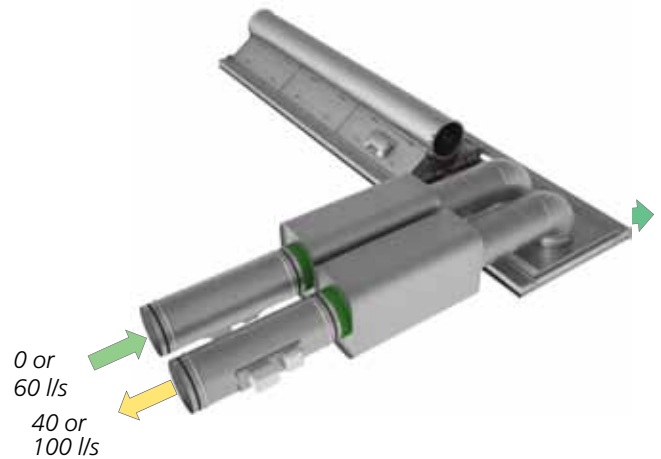

Figure 19. PACIFIC with extra supply air and extract air via T-AIR KIT VAV

T-EA-EXC

This accessory package is suitable for use when you want an integrated extract air solution with constant extract airflow. The EXC air register is installed in the extract air duct of the SA/EA module.

Technical data such as e.g. airflow and sound level can be obtained in ProSelect.



Figure 20. Pacific with extract air via T-EA-EXC

The plenum in the PACIFIC is designed so that the runs of connected ducting are always well above the profiled T-sections of the load-carrying ceiling grid system. This offers several advantages. One advantage is that there is never any risk of the ductwork colliding with the T-bar or that you will need to use special duct components. A second advantage is that the sound level will be minimised if you can connect straight runs of ducting. A third advantage is that you can connect the primary air duct to several units in series by allowing a certain portion of the air to pass through the first unit and on to the next one. The number of units that can be interconnected in a series depends on the airflow per unit and the selected connection size of the ducting. The sound level in the first unit in the series is the design level. By using the ProSelect Web software available at Swegon's home page www.swegon.com, you can easily calculate how many units you can connect in series.

When the SA/EA module is used, two products can be connected as a pair.



Figure 22. Two PACIFIC SA/EA connected as a pair



Figure 21. Several PACIFIC (without additional SA/EA module) connected in a series.

Comfort and commissioning functions

The ADC (Anti Draught Control) and VariFlow comfort and commissioning functions are also included as standard features.

ADC

ADC consists of a number of sections with adjustable fins arranged in the outlet of the unit. With a simple grip of the hand, the fins can be set to an appropriate angle to direct the discharge of air and in this way create the desired air distribution pattern. The standard setting for ADC is straight but the unit can be supplied factory-preset to a V-shape distribution pattern, if desired.

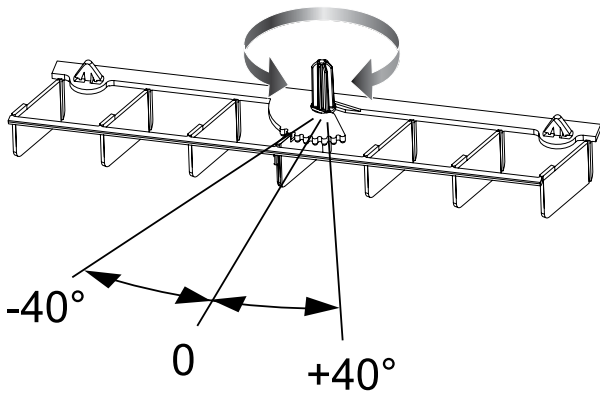

Figure 23. Detailed illustration of ADC

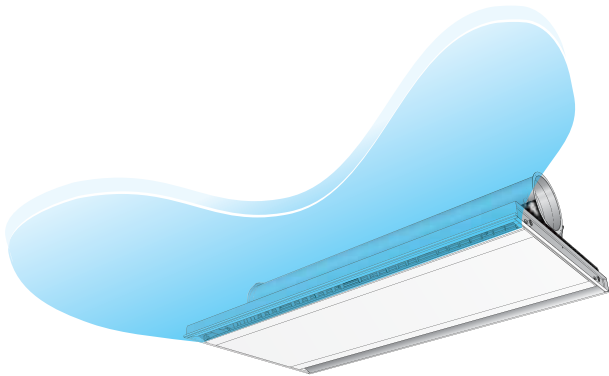

Figure 24. ADC set to the V-shape setting

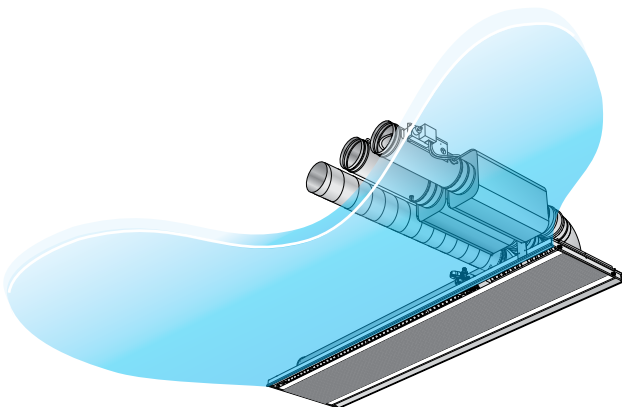

Figure 25. PACIFIC SA/EA with ADC set to V-shape diffusion pattern

VariFlow

VariFlow is the name of Swegon's unique adjustable nozzle strips. There are three airflow variants to choose from:

- LF = Low airflow
- MF = Medium Flow
- HF = High Flow

The most suitable airflow variant is selected depending on current airflow needs and future needs to possibly increase or decrease the airflow. The number of VariFlow nozzle strips varies depending on the length of the capacity module.

The strips are shown in different colours to make it easier to distinguish between them. The LF has a faint green shade, MF is grey and HF is black.

Table 1. Number of VariFlow nozzle strips per capacity module

Length of the capacity module (mm)	Number of VariFlow nozzle strips
1100	8
1600	12
2200	16
2700	20

The three different airflow variants of VariFlow nozzle strip can also be set to three different positions:

- L = Low flow
- M = Medium flow
- H = High flow

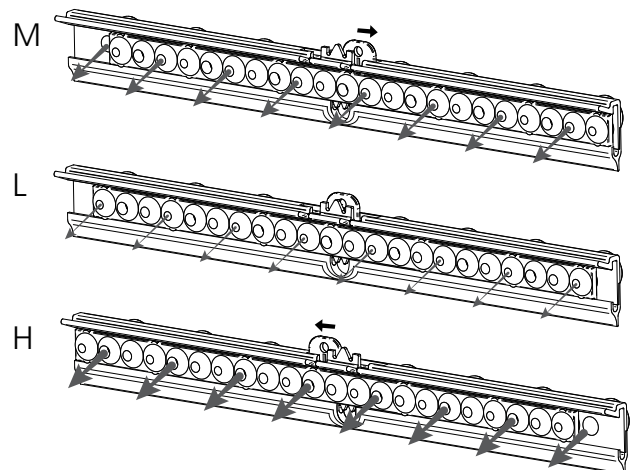

Figure 26. VariFlow nozzle strip set to three positions. L, M and H

By setting the VariFlow nozzle strips in different ways, you can easily set the beam to provide symmetric, asymmetric or displaced air distribution.

The K factors (COP) of the nozzle strips are mutually adapted to enable you to change how the airflow is distributed without affecting the total K factor of the climate beam. This means that you do not need to re-commission the unit when you make a change.

The sectional division of VariFlow offers tremendous flexibility. This technical brochure outlines only some of the settings that are possible to set. The PACIFIC can be supplied preset to basic settings for subsequent commissioning at the site or it can be supplied factory-preset to an optional setting, if so desired. Note that it is most often more advantageous to commission the beams at the building site considering the logistics, especially if the project involves a larger number of variants with different settings. For handling configurations, we recommend Swegon's new ProSelect Web software available at our home page: www.swegon.com.

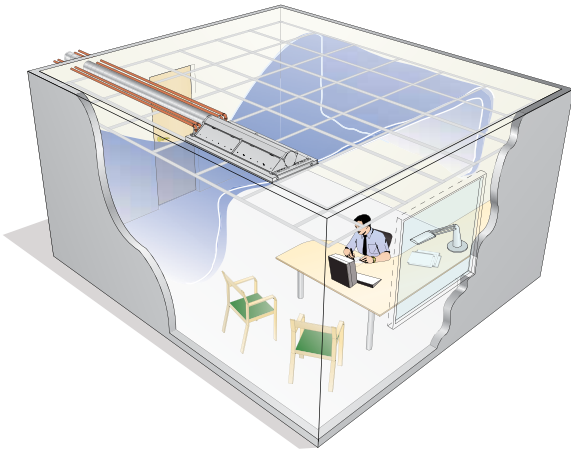

Figure 27. VariFlow with asymmetric airflow distribution

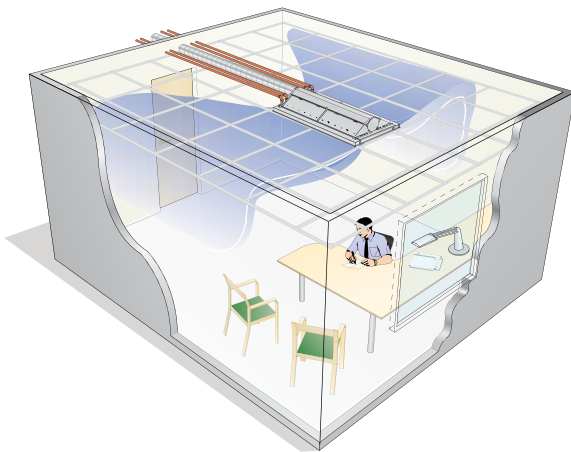

Figure 28. VariFlow with symmetric airflow distribution

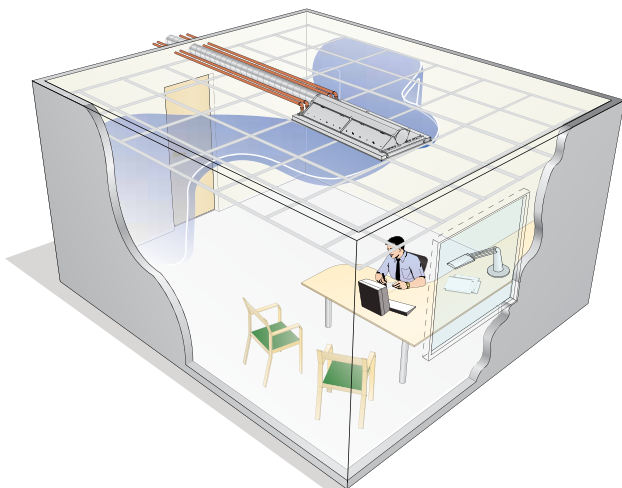

Figure 29. VariFlow with displaced airflow distribution



Figure 30. Design module

The design module serves as the interface to the current false ceiling system. Customised modules are available for integration in most false ceiling systems sold on the market.

- T-bar, 600 mm centre-to-centre
- T-bar, 625 mm centre-to-centre
- T-bar, 675 mm centre-to-centre
- T-bar, Imperial (USA)
- Sheet-metal ceiling coffer
- Strip grid systems
- Plasterboard ceiling (requires separate accessories)

The face plate of the design module is hinged and can be swung out from either side to a 90-degree open position. This completely exposes the coil for cleaning. Safety cords secure the face plate and ensure that it cannot fall down.



Figure 31. Hinged face plate.

In certain cases it could be advantageous to select a design module that is extra long in relation to the capacity module. One typical case is when the beam is installed in a plasterboard ceiling and there is a need for inspecting the valves and/or the commissioning damper. By employing a design module that is longer than the capacity module you get a built-in inspection cover per automatic control system. The inactive section of the design module is covered to avoid acoustic disturbance and so that the space above the false ceiling will not be visible from the room.



Figure 32. Built-in inspection cover through shorter capacity module or longer design module.



Figure 33. Pacific SA/EA with hinged face plate.

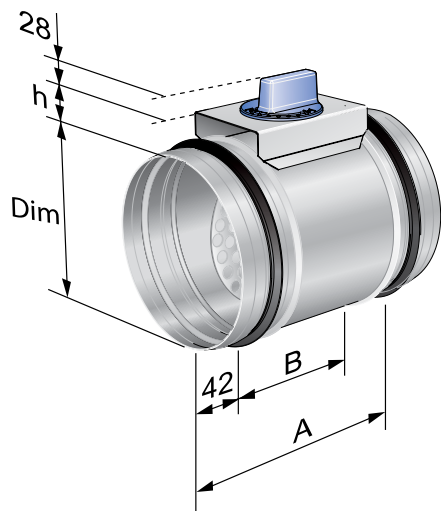

Figure 34. Pacific with additional SA/EA module and URC1 controller

Accessories for the PACIFIC climate beam

CRP Commissioning damper

100, 125 and 160 mm dia. circular commissioning damper with perforated damper blade and manual adjusting knob.



CRPc 9	A	B	h	Weight
Dim.	mm	mm	mm	kg
100	210	110	20	0.7
125	210	110	20	0.8
160	210	110	20	0.9

Connection piece, air, SYST CA

90° duct bend, used if the PACIFIC will be connected on the long side or vertically. Available in three dimensions: Ø100; Ø125 and Ø160 mm.



Figure 36. Connection piece, air – 90° duct bend, SYST CA 100/125/160-90

Connection piece, air – insertion joint, SYST AD1

SYST AD1 is used as an insertion joint between the PACIFIC and the duct system. Available in three dimensions: Ø100; Ø125 and Ø160 mm.



Figure 37. Connection piece, air – insertion joint, SYST AD1- 100, 125 or 160

Valve actuator

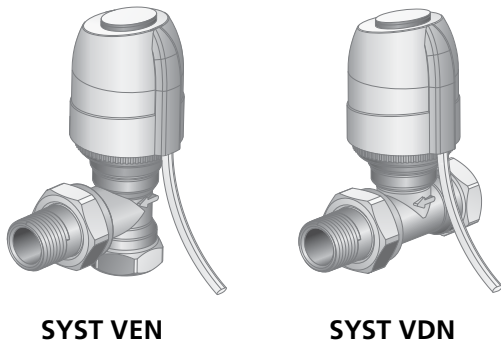

Figure 38. Valve actuator, angled and straight variant.

Side connection kit, water

The PACIFIC is as standard equipped with vertical water connections but can be converted to a unit with side connections by complementing it with a side connection kit.

This kit can be easily installed on the side required, by means of quick-fit, push-on couplings and matched copper tubing.

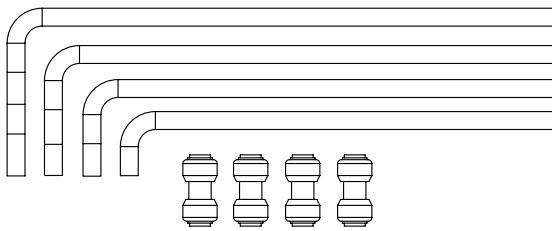

Figure 39. Side connection kit, SYST CK1

Horizontal connection kit, water

The PACIFIC is as standard equipped with vertical water connections but can be converted to a unit with horizontal connections by complementing it with a horizontal connection kit.

This kit can be easily installed by means of quick-fit, push-on couplings and matched copper tubing.

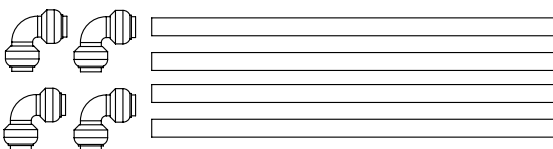

Figure 40. Horizontal connection kit, SYST CK2

Flexible connection hoses

Flexible hoses are available with quick-fit, push-on couplings as well as clamping ring couplings for quick and simply connection. The hoses are also available in various lengths. Note that clamp ring couplings require support sleeves inside the pipes.

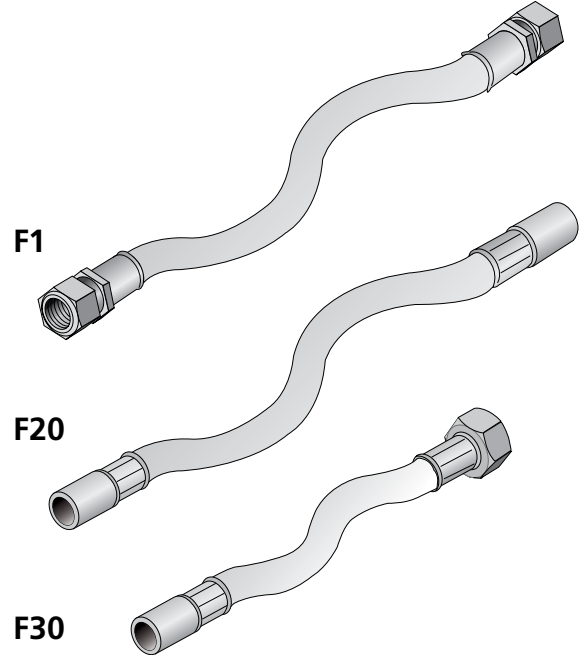

Figure 41. Flexible connection hoses, SYST FH

F1 = Flexible hoses with clamping ring couplings

F20 = Flexible hoses with quick-fit couplings (push-on)

F30 = Flexible hose with quick-fit, push-on coupling in one end and G20ID sleeve nut in the other end.

See the SYST FH Quick Selection Guide on the Internet.

Venting nipple, push-on

A venting nipple is available as a complement to the flexible hoses with push-on couplings. The venting nipple fits directly in the push-on hose coupling and can be fitted in an instant.

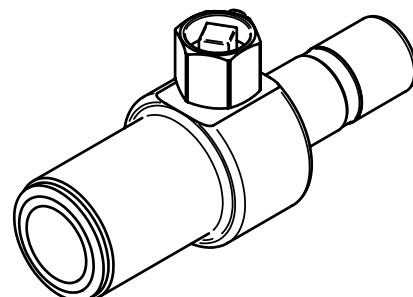

Figure 42. Venting nipple, SYST AR-12

Mounted control equipment

the PACIFIC is available with mounted control equipment, with cooling or cooling/heating valve as well as valve actuator.

Various options can be selected depending on which control module is selected.

URC1

Room temperature and airflow control system.

A URC1 room climate control system can be selected as an accessory.

On delivery, the control module is mounted on the PACIFIC climate beam. A so called sensor module containing occupancy and room temperature sensors is also supplied with the URC1. The sensor module should be installed at an appropriate location in the room.

The URC1 can control a valve actuator for cooling, a valve actuator for heating and two motor-driven dampers used in the SA/EA with T-AIR KIT VAV.

The desired set point for room temperature can be changed on the sensor module.

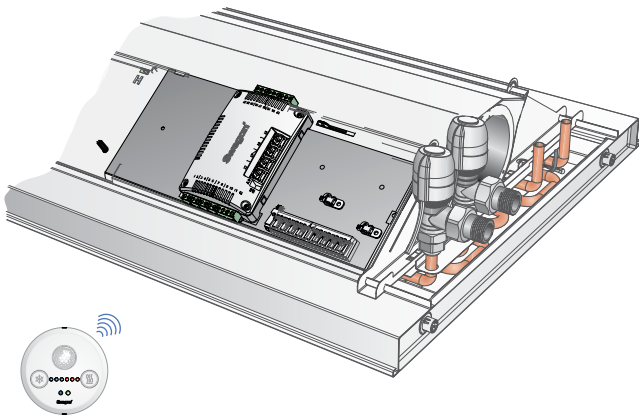

Figure 43. PACIFIC with mounted URC1 controller and sensor module.

LUNA

Control system for room temperature.

As an accessory you can select a LUNA room climate control system.

On delivery, the control module is mounted inside the PACIFIC climate beam, on the inner side of the perforated face plate.

The LUNA can control a valve actuator for cooling and a valve actuator for heating.

If the LUNA is mounted inside the PACIFIC, it can only control one valve actuator for cooling. If it is desirable to also control heating, the control module should be installed at an appropriate place in the room.

The room temperature sensor and the setpoint selector switch are fitted on the control module itself.

(Cannot be combined together with the T-AIR KIT VAV accessory kit).

For more information, see the LUNA Product Datasheet.

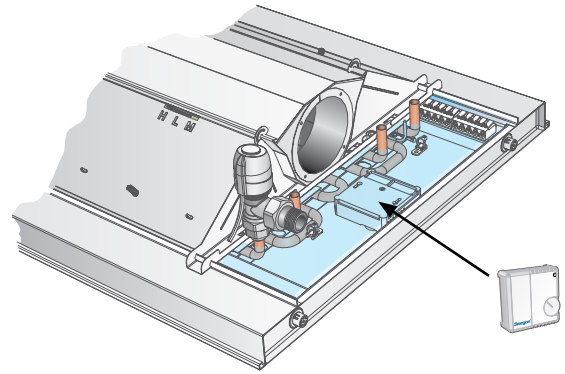

Figure 44. PACIFIC with mounted LUNA controller.

CONDUCTOR

Network-connectable control system for controlling the room temperature and air quality.

As an accessory you can select a Conductor room climate control system.

On delivery, the control module is mounted on the PACIFIC climate beam.

The Conductor can control a valve actuator for cooling, a valve actuator for heating, two motor-driven dampers and a motor-driven extract air damper.

(Cannot be combined together with the T-AIR KIT VAV accessory kit).

the Conductor can be supplemented with a room unit with digital display, RU.

The RU unit communicates wirelessly or via wired connection with the control module. All settings can be entered directly in the RU unit.

For more information, see the Conductor Product Data-sheet.

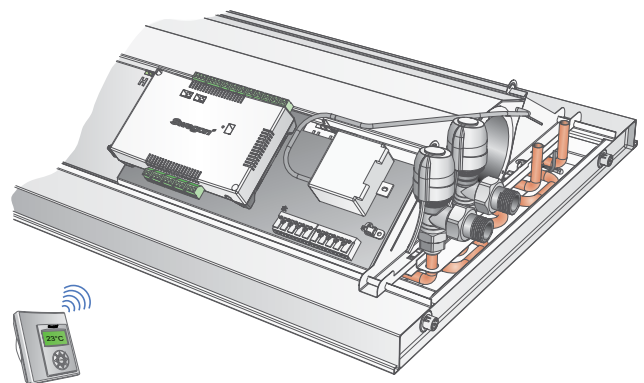

Figure 45. PACIFIC with mounted Conductor controller and RU room unit.

Installation

The PACIFIC is designed for installation flush-mounted in the majority of false ceilings available on the market.

- T-bar with 600 mm c-c and plasterboard ceilings:
Width: 594 mm
Lengths: 1,194; 1,794; 2,394 and 2,994 mm
- T-bar with 600 mm c-c in combination with 100 mm wide strip grid systems, 1800 mm c-c
Width: 594 mm
Length: 1,715 mm
- T-bar with 625 mm c-c
Width: 617 mm
Lengths: 1242; 1867; 2,492 mm
- T-bar with 675 mm c-c
Width: 667 mm
Lengths: 1,342; 2,017; 2,692 mm
- T-bar with IP units (USA)
Width: 23.7 inches (603 mm)
Length: 47.8, 71.8, 95.8, 119.8 inches (1213; 1823; 2433; 3043 mm)
- Clip-in ceiling / sheet metal ceiling coffers 598 mm
Lengths: 1,198; 1,498; 1,698; 1,715; 1,798; 2,398; 2,998 mm

Connection dimensions

Cooling (water):	Cu Ø 12 x 1.0 mm plain pipe end
Heating (water):	Cu Ø 12 x 1.0 mm plain pipe end
Air:	100 dia. insertion joint; 125 or 160 mm
SA/EA module:	Spigot Ø160 mm

Recommended limit values

Max. recommended operating pressure:	1600 kPa
Max. recommended test pressure:	2,400 kPa
Min. permissible nozzle pressure:	50 Pa
Min. cooling water flow*	0.03 l/s
Capacity module: L = 1,100; 1,600 mm:	
Min. cooling water flow*	0.045 l/s
Capacity module: L = 2200; 2,700 mm:	
Min. permissible heating water flow*:	0.013 l/s
Increase in temperature, cooling water:	2-5 K
Decrease in temperature, heating water:	5-10 K
Min. permissible inlet flow temperature:	Should always be sized avoid condensation
Min. permissible inlet flow temperature:	60° C

* The min. recommended water flows ensure evacuation of any air pockets in the circuit.

Suspension:

The PACIFIC is supplied with four mounting brackets and self-tapping screws packaged separately and supplied with each unit. The pre-punched holes in each mounting bracket simplify the fastening work. The mounting brackets are designed enabling them to be turned in any optional direction depending to suit type of suspension system selected. Turned inward, the mounting brackets offer simple installation by means of mounting strips. Turned outward, the mounting brackets work at their best for suspending the beams by means of size M8 threaded rods. Mounting strips and threaded rods are not supplied with the unit.

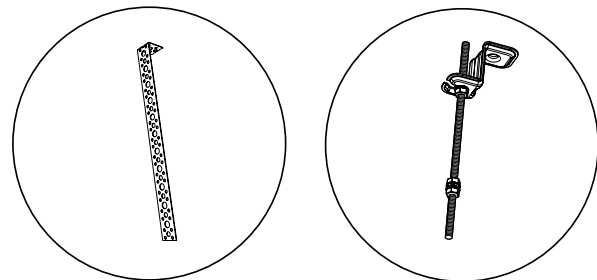

Figure 46. Suspension variant with mounting brackets and threaded rods respectively.

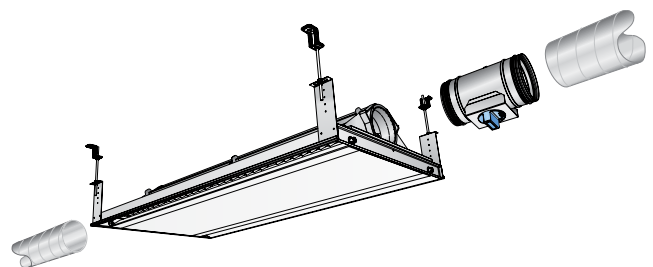

Figure 47. Installation of PACIFIC, here suspended by means of threaded rods.

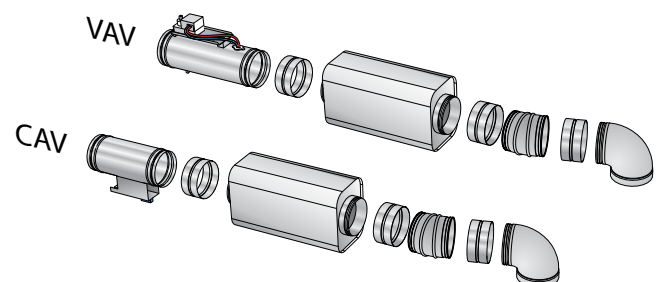
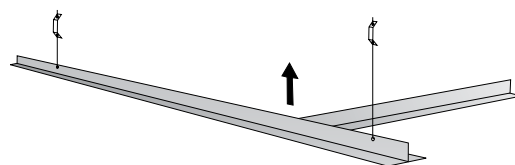

Figure 48. Installation of SA/EA kit, VAV with motor control and CAV with manual knob.

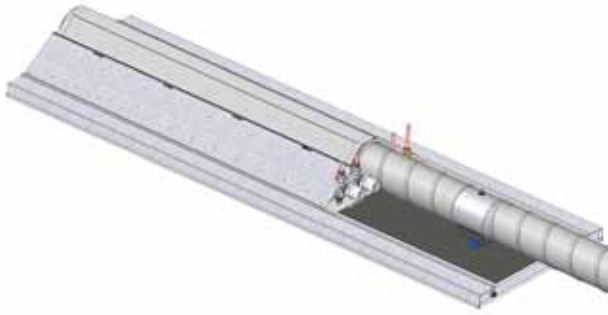

Figure 49. Example with straight air connection and vertical water connections.

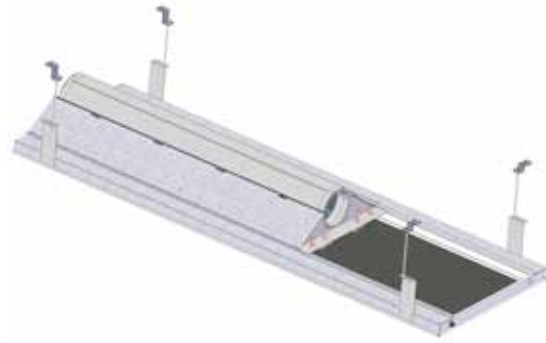

Figure 52. Example of beam suspension with threaded rods.

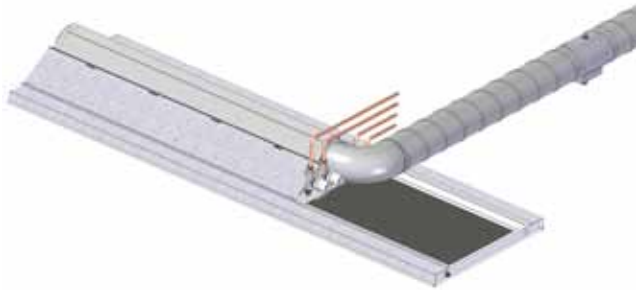

Figure 50. Example with air and water connections from the side.



Figure 53. Example of beam suspension with mounting strips.

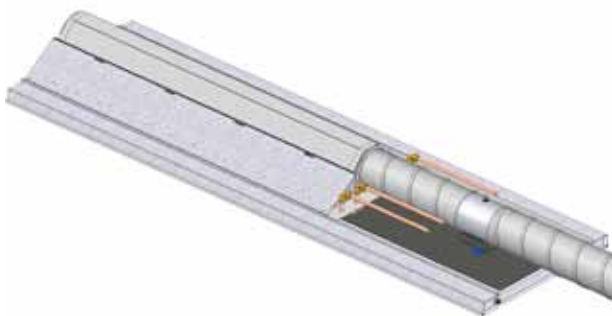

Figure 51. Example with straight, horizontal air and water connections.

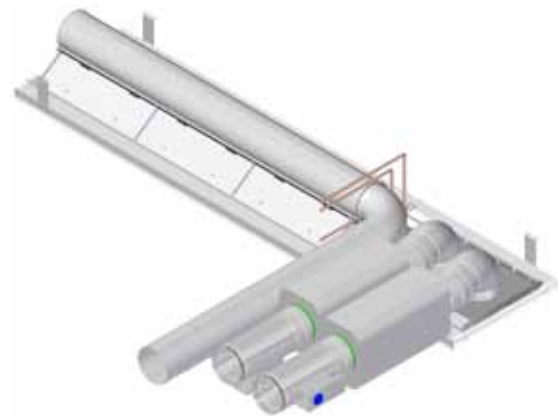

Figure 54. Example with PACIFIC SAE/EA incl. CAV kit with air and water connections from the side.

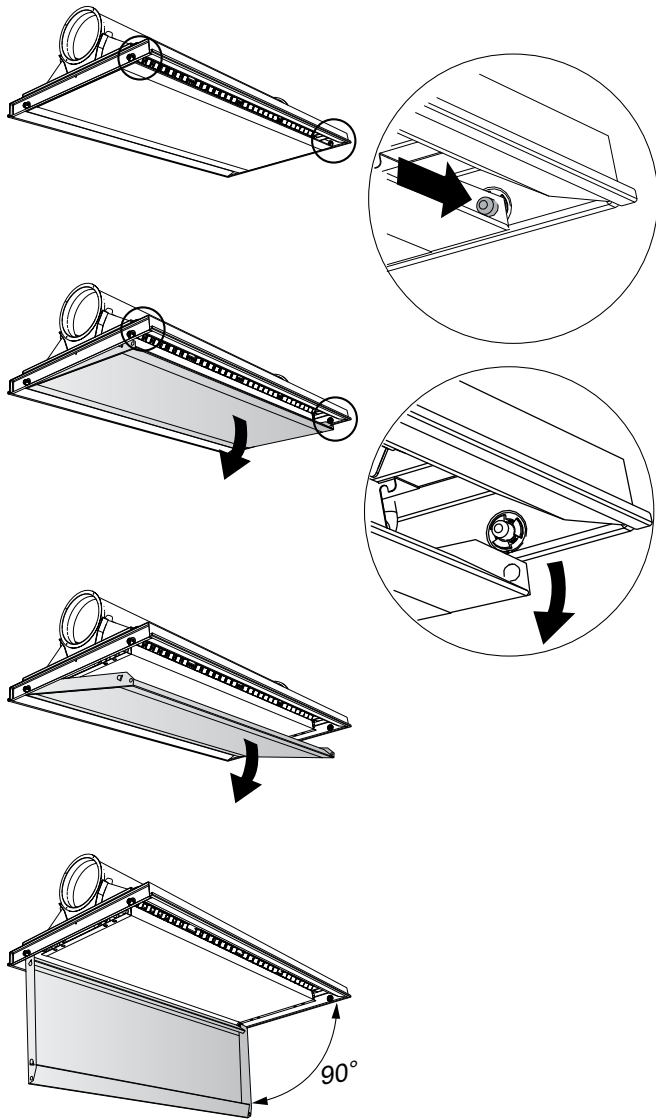

Figure 55. Simple opening of the face plate from its hinges on optional long side.

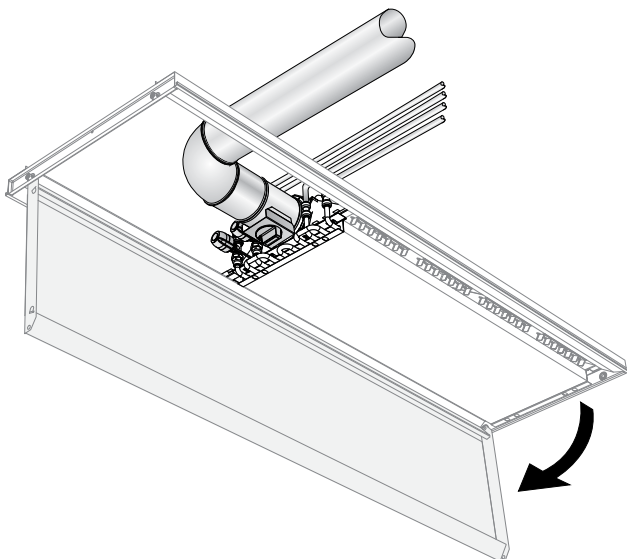

Figure 56. Example showing accessibility to an inactive section and horizontal connections to the side when the face plate is swung open from its hinges.

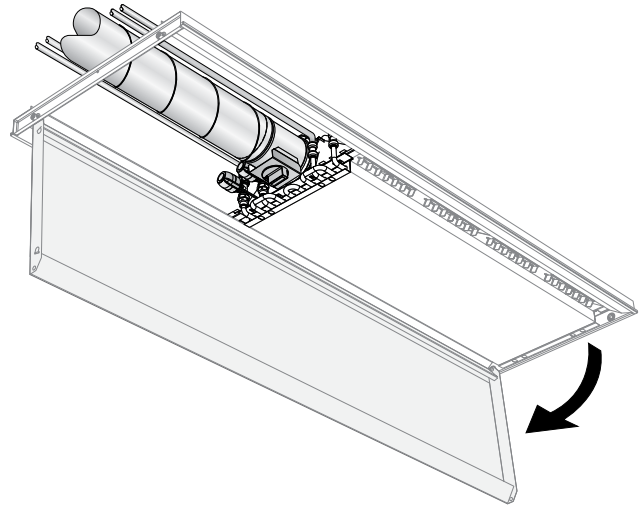

Figure 57. Example showing accessibility to an inactive section with straight horizontal connections when the face plate is swung open from its hinges.

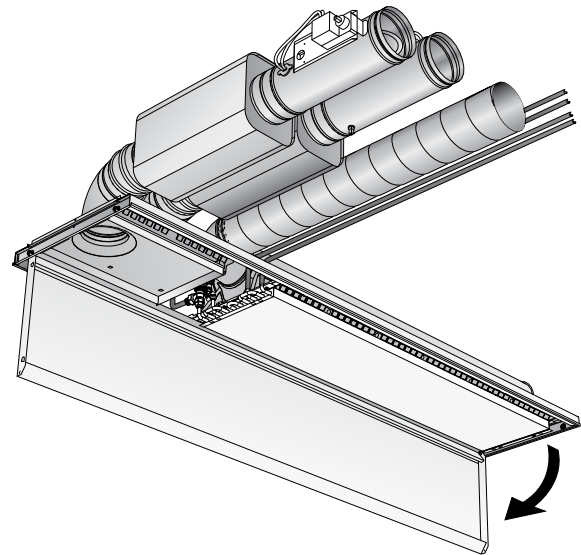

Figure 58. Example showing accessibility to a PACIFIC SA/EA with VAV-kit when the face plate is swung open from its hinges.

Technical data

Cooling

The capacities are measured in conformity with EN 15116.

Sizing guides, Tables 3 to 14.

The tables are arranged according to airflow variant. Select the relevant table to suit your application on the basis of airflow, nozzle pressure and capacity requirements. The following can be read in the sizing guide:

1. Unit length (mm)
2. Nozzle setting, left-hand and right-hand side.
3. Primary airflow q_1 (l/s) and (m³/h)
4. Sound pressure level $L_p(A)$ for open damper with one air connection of Ø100, Ø125 or Ø160 (dB(A)) (dB(A))
5. Airborne cooling capacity, P_1 (W)
6. Waterborne cooling capacity, P_1 (W)
7. Pressure drop constant, air, k_{pk}

N.B.! The total cooling capacity is the sum of the airborne and waterborne cooling capacities.

1	2	3	4	5	6	7
-	-	-	-	-	-	-
-	-	-	-	-	-	-
-	-	-	-	-	-	-
-	-	-	-	-	-	-
-	-	-	-	-	-	-
-	-	-	-	-	-	-
-	-	-	-	-	-	-
-	-	-	-	-	-	-
-	-	-	-	-	-	-
-	-	-	-	-	-	-
-	-	-	-	-	-	-
-	-	-	-	-	-	-
-	-	-	-	-	-	-
-	-	-	-	-	-	-
-	-	-	-	-	-	-
-	-	-	-	-	-	-
-	-	-	-	-	-	-
-	-	-	-	-	-	-
-	-	-	-	-	-	-
-	-	-	-	-	-	-
-	-	-	-	-	-	-
-	-	-	-	-	-	-
-	-	-	-	-	-	-

Pressure drop for the cooling circuit

The following formula for calculating the pressure drop in the cooling circuit:

$$\Delta p_k = (q_k / k_{pk})^2 \text{ [kPa]}$$

Δp_k = pressure drop in cooling circuit (kPa)

q_k = cooling water flow (l/s), read from Diagram 1.

k_{pk} = pressure drop constant read from Table 2.

Table 2. Pressure drop constant, water

Capacity module	Pressure drop constant, water
Length (mm)	k_{pk}
1100	0.0232
1600	0.0201
2200	0.0376
2700	0.0353

The cooling capacity of the primary air for climate beam and additional SA module

The following formula can be used for calculating the cooling capacity of the primary air for the climate beam and the additional SA module:

$$P_1 = q_1 \times 1.2 \times \Delta T_1$$

P_1 = cooling capacity of the primary air (W)

q_1 = the primary airflow (l/s)

ΔT_1 = Temperature differential between the temperature of the primary air and the room temperature (K)

Designations

P: Capacity (W, kW)

t_r : Room temperature (°C)

t_m Mean water temperature (°C)

v: Velocity (m/s)

q: Airflow (l/s)

p: Pressure, (Pa, kPa)

ΔT_m : Temperature differential [$t_r - t_m$] (K)

ΔT : Temperature differential, between inlet – return (K)

Supplementary index: k = cooling, v = heating, l = air, i = commissioning

Cooling

Diagram 1. The cooling capacity P_k (W) as a function of the change in temperature ΔT_k (K) and the cooling water flow q_k (l/s). The capacity of the cooling water can also be calculated by using the following formula:

$$P_k = 4186 \times q_k \times \Delta T_k$$

P_k = Cooling capacity of the water (W)

q_k = Cooling water flow (l/s)

ΔT_k = Temperature differential between the cooling water inlet flow and return (K)

Diagram 2. Pressure drop Δp_k (kPa) in the cooling water circuit, as a function of the cooling water flow q_k (l/s) and the length of the unit.

Diagrams 3a-3b. Correction factor k for cooling capacity P_k (W) as a function of cooling the water flow q_k (l/s). Different water flows have a certain effect on the cooling capacity depending on how turbulent the water flow is. By checking the calculated water flow against Diagram 3a/3b, the capacity specified in Tables 3 – 14 may need to be slightly adjusted up or down according to the following formula:

$$P_{corrected} (W) = P_k (Tables\ 3-14) \times k (Diagram\ 3a/3b)$$

Diagram 1. Water flow – Cooling capacity

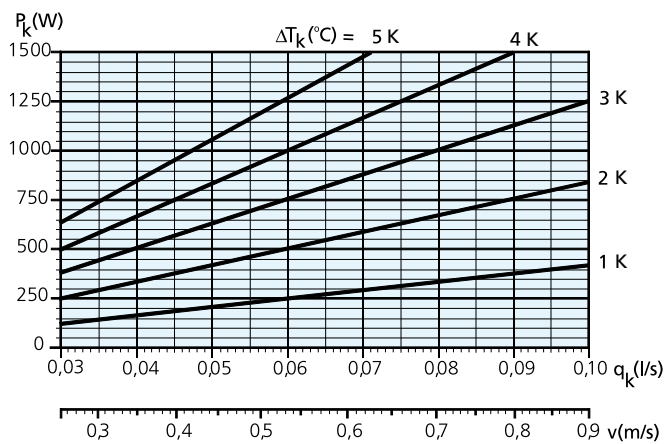

Diagram 2. Pressure drop – water flow, cooling

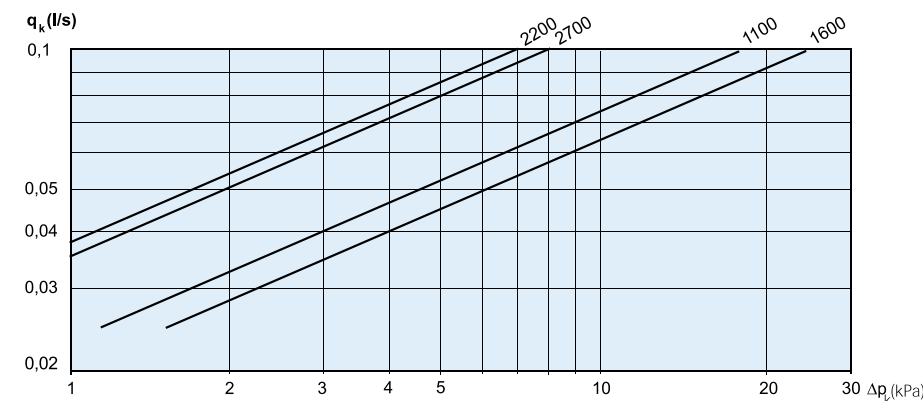

Diagram 3a. Water flow – capacity correction, cooling
Length of Capacity module: 1100 and 1,600 mm

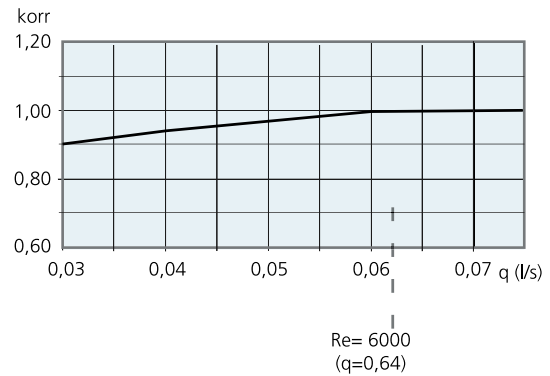

Diagram 3b. Water flow – capacity correction, cooling
Length of Capacity module: 2,200 and 2,700 mm

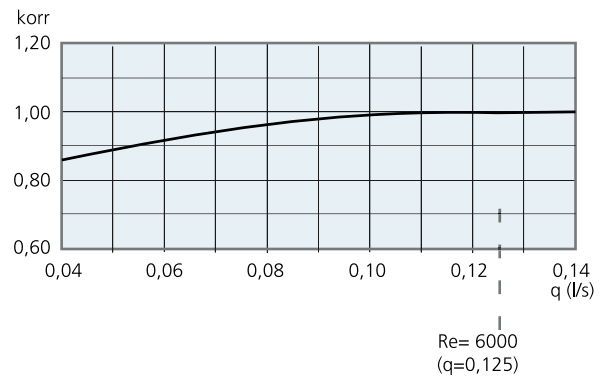

Table 3. Data – Cooling. Sizing guide for the PACIFIC LF airflow variant with symmetric air distribution (50/50%), 50 Pa nozzle pressure

Capacity module	Nozzle setting		Airflow		Sound level, dB(A) *			Cooling capacity, primary air (W)				Cooling capacity of the water (W)						Pressure drop constant, air	
	Length	Side										Connection (mm)			ΔT_l				ΔT_{mk}
(mm)	50%	50%	(l/s)	(m ³ /h)	Ø100	Ø125	Ø160	6	8	10	12	6	7	8	9	10	11	12	k_{pl}
1100 **	4L	4L	5.9	21.2	<20	<20	<20	42	57	71	85	208	241	274	306	338	370	402	0.83
1100 **	4M	4M	9.5	34.2	<20	<20	<20	68	91	114	137	255	298	341	385	429	472	516	1.34
1100 **	4H	4H	12.7	45.7	<20	<20	<20	91	122	152	183	286	335	385	434	484	535	585	1.79
1600 **	6L	6L	8.8	31.7	<20	<20	<20	63	84	106	127	313	362	411	459	507	555	603	1.25
1600 **	6M	6M	14.3	51.5	<20	<20	<20	103	137	172	206	382	447	512	578	643	709	774	2.02
1600 **	6H	6H	19	68.4	<20	<20	<20	137	182	228	274	429	503	577	652	727	802	877	2.69
2200 ***	8L	8L	11.7	42.1	<20	<20	<20	84	112	140	168	425	492	559	625	690	755	820	1.66
2200 ***	8M	8M	19	68.4	<20	<20	<20	137	182	228	274	520	608	697	786	875	964	1054	2.69
2200 ***	8H	8H	25.3	91.1	24	<20	<20	182	243	304	364	583	684	785	886	988	1091	1193	3.58
2700 ***	10L	10L	14.7	52.9	<20	<20	<20	106	141	176	212	530	613	696	778	859	941	1022	2.08
2700 ***	10M	10M	23.8	85.7	23	<20	<20	171	228	286	343	647	757	868	979	1090	1201	1312	3.36
2700 ***	10H	10H	31.7	114.1	29	22	<20	228	304	380	456	726	852	978	1104	1231	1358	1486	4.48

Table 4. Data – Cooling. Sizing guide for the PACIFIC LF airflow variant with asymmetric air distribution (30/70%), 50 Pa nozzle pressure

Capacity module	Nozzle setting		Airflow		Sound level, dB(A) *			Cooling capacity, primary air (W)				Cooling capacity of the water (W)						Pressure drop constant, air	
	Length	Side										Connection			ΔT_l				ΔT_{mk}
(mm)	30%	70%	(l/s)	(m ³ /h)	Ø100	Ø125	Ø160 mm	6	8	10	12	6	7	8	9	10	11	12	k_{pl}
1100 **	4L	4H	9.3	33.5	<20	<20	<20	67	89	112	134	263	308	352	397	441	486	531	1.31
1600 **	6L	6H	13.9	50.0	<20	<20	<20	100	133	167	200	390	456	522	588	654	720	786	1.97
2200 ***	8L	8H	18.5	66.6	<20	<20	<20	133	178	222	266	533	623	713	804	894	984	1075	2.62
2700 ***	10L	10H	23.2	83.5	23	<20	<20	167	223	278	334	664	776	888	1001	1113	1226	1339	3.28

* The specified sound level is applicable to straight connection without duct bend and commissioning damper.

Room attenuation = 4 dB.

**) = The water capacity is specified for a water flow of 0.064 l/s and can vary depending on the installation and how the ADC air deflectors are set.

***) = The water capacity is specified for a water flow of 0.125 l/s and can vary depending on the installation and how the ADC air deflectors are set.

Detailed acoustic data can be obtained by sizing with Swegon’s new ProSelect Web software available at Swegon’s home page: www.swegon.com.

Table 5. Data – Cooling. Sizing guide for the PACIFIC LF airflow variant with symmetric air distribution (50/50%), 100 Pa nozzle pressure

Capacity module	Nozzle setting		Airflow		Sound level, dB(A) *			Cooling capacity, primary air (W)				Cooling capacity of the water (W)						Pressure drop constant, air	
	Length	Side			Connection (mm)			ΔT_1				ΔT_{mk}							
(mm)	50%	50%	(l/s)	(m ³ /h)	Ø100	Ø125	Ø160	6	8	10	12	6	7	8	9	10	11	12	k_{pl}
1100 **	4L	4L	8.3	29.9	<20	<20	<20	60	80	100	120	281	327	372	417	462	507	552	0.83
1100 **	4M	4M	13.4	48.2	<20	<20	<20	96	129	161	193	338	396	454	512	571	629	688	1.34
1100 **	4H	4H	17.9	64.4	<20	<20	<20	129	172	215	258	371	436	502	567	634	700	767	1.79
1600 **	6L	6L	12.5	45.0	<20	<20	<20	90	120	150	180	422	490	558	626	693	760	827	1.25
1600 **	6M	6M	20.2	72.7	20	<20	<20	145	194	242	291	507	594	681	768	856	944	1031	2.02
1600 **	6H	6H	26.9	96.8	25	<20	<20	194	258	323	387	556	654	752	851	951	1051	1151	2.69
2200 ***	8L	8L	16.6	59.8	<20	<20	<20	120	159	199	239	574	667	759	851	943	1035	1126	1.66
2200 ***	8M	8M	26.9	96.8	26	20	<20	194	258	323	387	690	808	927	1045	1164	1284	1403	2.69
2200 ***	8H	8H	35.8	128.9	32	25	<20	258	344	430	516	757	890	1024	1158	1293	1429	1566	3.58
2700 ***	10L	10L	20.8	74.9	21	<20	<20	150	200	250	300	715	831	946	1060	1175	1288	1402	2.08
2700 ***	10M	10M	33.6	121.0	30	24	<20	242	323	403	484	860	1007	1154	1302	1450	1599	1748	3.36
2700 ***	10H	10H	44.8	161.3	38	31	20	323	430	538	645	943	1108	1275	1442	1611	1780	1950	4.48

Table 6. Data – Cooling. Sizing guide for the PACIFIC LF airflow variant with asymmetric air distribution (75/25%), 100 Pa nozzle pressure

Capacity module	Nozzle setting		Airflow		Sound level, dB(A) *			Cooling capacity, primary air (W)				Cooling capacity of the water (W)						Pressure drop constant, air	
	Length	Side			Connection (mm)			ΔT_1				ΔT_{mk}							
(mm)	30%	70%	(l/s)	(m ³ /h)	Ø100	Ø125	Ø160	6	8	10	12	6	7	8	9	10	11	12	k_{pl}
1100 **	4L	4H	13.1	47.2	<20	<20	<20	94	126	157	189	345	404	464	524	584	644	704	1.31
1600 **	6L	6H	19.7	70.9	20	<20	<20	142	189	236	284	511	599	687	776	865	954	1043	1.97
2200 ***	8L	8H	26.2	94.3	25	<20	<20	189	252	314	377	699	819	940	1061	1182	1304	1426	2.62
2700 ***	10L	10H	32.8	118.1	30	23	<20	236	315	394	472	871	1020	1170	1321	1472	1624	1776	3.28

* The specified sound level is applicable to straight connection without duct bend and commissioning damper.

Room attenuation = 4 dB.

**) = The water capacity is specified for a water flow of 0.064 l/s and can vary depending on the installation and how the ADC air deflectors are set.

***) = The water capacity is specified for a water flow of 0.125 l/s and can vary depending on the installation and how the ADC air deflectors are set.

Detailed acoustic data can be obtained by sizing with Swegon’s new ProSelect Web software available at Swegon’s home page: www.swegon.com.

PACIFIC

Table 7. Data – Cooling. Sizing guide for the PACIFIC MF airflow variant with symmetric air distribution (50/50%), 50 Pa nozzle pressure

Capacity module	Nozzle setting		Airflow		Sound level, dB(A) *			Cooling capacity, primary air (W)				Cooling capacity of the water (W)						Pressure drop constant, air	
	Length	Side																	Connection (mm)
(mm)	50%	50%	(l/s)	(m³/h)	Ø100	Ø125	Ø160	6	8	10	12	6	7	8	9	10	11	12	k_{pl}
1100 **	4L	4L	8.6	31.0	<20	<20	<20	62	83	103	124	245	286	328	370	412	454	497	1.22
1100 **	4M	4M	14.5	52.2	<20	<20	<20	104	139	174	209	307	359	412	464	517	570	623	2.05
1100 **	4H	4H	18.5	66.6	22	21	20	133	178	222	266	332	389	447	505	563	621	679	2.62
1600 **	6L	6L	12.9	46.4	<20	<20	<20	93	124	155	186	367	429	492	555	618	681	745	1.82
1600 **	6M	6M	21.7	78.1	21	<20	<20	156	208	260	312	460	538	617	696	775	855	934	3.07
1600 **	6H	6H	27.9	100.4	27	23	22	201	268	335	402	498	584	670	757	844	932	1019	3.94
2200 ***	8L	8L	17.2	61.9	<20	<20	<20	124	165	206	248	499	584	670	755	841	927	1013	2.43
2200 ***	8M	8M	29	104.4	27	21	<20	209	278	348	418	626	733	840	947	1055	1163	1271	4.1
2200 ***	8H	8H	37.1	133.6	33	28	24	267	356	445	534	678	795	912	1030	1149	1267	1387	5.25
2700 ***	10L	10L	21.5	77.4	22	<20	<20	155	206	258	310	622	728	834	941	1047	1155	1262	3.04
2700 ***	10M	10M	36.2	130.3	32	26	<20	261	348	434	521	779	912	1046	1180	1314	1448	1583	5.12
2700 ***	10H	10H	46.4	167.0	39	33	25	334	445	557	668	844	990	1136	1283	1431	1578	1727	6.56

Table 8. Data – Cooling. Sizing guide for the PACIFIC MF airflow variant with asymmetric air distribution (30/70%), 50 Pa nozzle pressure

Capacity module	Nozzle setting		Airflow		Sound level, dB(A) *			Cooling capacity, primary air (W)				Cooling capacity of the water (W)						Pressure drop constant, air	
	Length	Side																	Connection (mm)
(mm)	30%	70%	(l/s)	(m³/h)	Ø100	Ø125	Ø160	6	8	10	12	6	7	8	9	10	11	12	k_{pl}
1100 **	4L	4H	13.6	49.0	<20	<20	<20	98	131	163	196	304	357	409	462	515	568	621	1.92
1600 **	6L	6H	20.4	73.4	22	20	20	147	196	245	294	457	535	614	693	773	853	933	2.88
2200 ***	8L	8H	27.2	97.9	27	22	21	196	261	326	392	621	728	835	943	1051	1159	1268	3.84
2700 ***	10L	10H	33.9	122.0	31	25	22	244	325	407	488	774	907	1040	1175	1309	1444	1580	4.8

* The specified sound level is applicable to straight connection without duct bend and commissioning damper.

Room attenuation = 4 dB.

**) = The water capacity is specified for a water flow of 0.064 l/s and can vary depending on the installation and how the ADC air deflectors are set.

***) = The water capacity is specified for a water flow of 0.125 l/s and can vary depending on the installation and how the ADC air deflectors are set.

Detailed acoustic data can be obtained by sizing with Swegon’s new ProSelect Web software available at Swegon’s home page: www.swegon.com.

Table 9. Data – Cooling. Sizing guide for the PACIFIC MF airflow variant with symmetric air distribution (50/50%), 100 Pa nozzle pressure

Capacity module	Nozzle setting		Airflow		Sound level, dB(A) *			Cooling capacity, primary air (W)				Cooling capacity of the water (W)						Pressure drop constant, air	
	Length (mm)	Side										Connection (mm)			ΔT_i				ΔT_{mk}
		50%	50%	(l/s)	(m ³ /h)	Ø100	Ø125	Ø160	6	8	10	12	6	7	8	9	10	11	12
1100 **	4L	4L	12.2	43.9	<20	<20	<20	88	117	146	176	326	382	438	495	552	609	666	1.22
1100 **	4M	4M	20.5	73.8	21	<20	<20	148	197	246	295	393	461	529	598	667	737	807	2.05
1100 **	4H	4H	26.2	94.3	29	28	27	189	252	314	377	423	496	569	643	717	791	865	2.62
1600 **	6L	6L	18.2	65.5	<20	<20	<20	131	175	218	262	489	573	658	742	828	913	999	1.82
1600 **	6M	6M	30.7	110.5	28	22	<20	221	295	368	442	589	691	794	897	1001	1106	1210	3.07
1600 **	6H	6H	39.4	141.8	35	31	29	284	378	473	567	635	744	854	964	1075	1186	1297	3.94
2200 ***	8L	8L	24.3	87.5	24	<20	<20	175	233	292	350	665	779	895	1010	1126	1242	1359	2.43
2200 ***	8M	8M	41	147.6	35	29	21	295	394	492	590	801	940	1080	1221	1362	1504	1646	4.1
2200 ***	8H	8H	52.5	189.0	43	37	31	378	504	630	756	863	1012	1162	1312	1463	1614	1765	5.25
2700 ***	10L	10L	30.4	109.4	28	22	<20	219	292	365	438	828	971	1114	1258	1402	1547	1692	3.04
2700 ***	10M	10M	51.2	184.3	42	35	23	369	492	614	737	998	1171	1345	1521	1696	1873	2051	5.12
2700 ***	10H	10H	65.6	236.2	49	43	33	472	630	787	945	1075	1261	1447	1634	1822	2010	2198	6.56

Table 10. Data – Cooling. Sizing guide for the PACIFIC MF airflow variant with asymmetric air distribution (75/25%), 100 Pa nozzle pressure

Capacity module	Nozzle setting		Airflow		Sound level, dB(A) *			Cooling capacity, primary air (W)				Cooling capacity of the water (W)						Pressure drop constant, air	
	Length (mm)	Side										Connection (mm)			ΔT_i				ΔT_{mk}
		30%	70%	(l/s)	(m ³ /h)	Ø100	Ø125	Ø160	6	8	10	12	6	7	8	9	10	11	12
1100 **	4L	4H	19.2	69.1	25	24	24	138	184	230	276	392	460	528	596	664	733	802	1.92
1600 **	6L	6H	28.8	103.7	29	27	26	207	276	346	415	589	690	792	894	997	1100	1203	2.88
2200 ***	8L	8H	38.4	138.2	35	30	28	276	369	461	553	800	938	1077	1216	1356	1496	1636	3.84
2700 ***	10L	10H	48	172.8	40	34	29	346	461	576	691	997	1169	1342	1515	1689	1863	2038	4.8

* The specified sound level is applicable to straight connection without duct bend and commissioning damper.

Room attenuation = 4 dB.

**) = The water capacity is specified for a water flow of 0.064 l/s and can vary depending on the installation and how the ADC air deflectors are set.

***) = The water capacity is specified for a water flow of 0.125 l/s and can vary depending on the installation and how the ADC air deflectors are set.

Detailed acoustic data can be obtained by sizing with Swegon’s new ProSelect Web software available at Swegon’s home page: www.swegon.com.

Table 11. Data – Cooling. Sizing guide for the PACIFIC HF airflow variant with symmetric air distribution (50/50%), 50 Pa nozzle pressure

Capacity module	Nozzle setting		Airflow		Sound level, dB(A) *			Cooling capacity, primary air (W)				Cooling capacity of the water (W)						Pressure drop constant, air	
	Length	Side										Connection (mm)			ΔT_l				ΔT_{mk}
(mm)	50%	50%	(l/s)	(m³/h)	Ø100	Ø125	Ø160	6	8	10	12	6	7	8	9	10	11	12	k_{pl}
1100 **	4L	4L	8.6	31.0	<20	<20	<20	62	83	103	124	243	283	323	363	403	443	483	1.22
1100 **	4M	4M	16.8	60.5	<20	<20	<20	121	161	202	242	316	369	423	476	529	583	637	2.37
1100 **	4H	4H	22.2	79.9	22	<20	<20	160	213	266	320	342	401	461	521	578	642	702	3.14
1600 **	6L	6L	12.9	46.4	<20	<20	<20	93	124	155	186	365	425	485	545	605	665	725	1.82
1600 **	6M	6M	25.1	90.4	24	<20	<20	181	241	301	361	474	554	634	714	794	874	955	3.55
1600 **	6H	6H	33.2	119.5	30	24	<20	239	319	398	478	513	602	692	781	867	962	1053	4.7
2200 ***	8L	8L	17.2	61.9	<20	<20	<20	124	165	206	248	496	578	660	741	823	904	986	2.43
2200 ***	8M	8M	33.5	120.6	30	24	<20	241	322	402	482	645	753	862	971	1080	1190	1299	4.74
2200 ***	8H	8H	44.3	159.5	38	31	21	319	425	532	638	698	819	941	1063	1179	1309	1433	6.27
2700 ***	10L	10L	21.5	77.4	22	<20	<20	155	206	258	310	618	720	822	923	1025	1127	1228	3.04
2700 ***	10M	10M	41.9	150.8	36	29	<20	302	402	503	603	803	938	1074	1210	1346	1482	1618	5.92
2700 ***	10H	10H	55.4	199.4	44	38	24	399	532	665	798	869	1020	1172	1324	1469	1631	1785	7.84

Table 12. Data – Cooling. Sizing guide for the PACIFIC HF airflow variant with asymmetric air distribution (30/70%), 50 Pa nozzle pressure

Capacity module	Nozzle setting		Airflow		Sound level, dB(A) *			Cooling capacity, primary air (W)				Cooling capacity of the water (W)						Pressure drop constant, air	
	Length	Side										Connection (mm)			ΔT_l				ΔT_{mk}
(mm)	30%	70%	(l/s)	(m³/h)	Ø100	Ø125	Ø160	6	8	10	12	6	7	8	9	10	11	12	k_{pl}
1100 **	4L	4H	15.4	55.4	<20	<20	<20	111	148	185	222	314	368	423	477	529	586	641	2.18
1600 **	6L	6H	23.1	83.2	23	<20	<20	166	222	277	333	472	553	634	715	794	879	962	3.26
2200 ***	8L	8H	30.8	110.9	28	22	<20	222	296	370	444	643	753	864	975	1082	1199	1311	4.35
2700 ***	10L	10H	38.5	138.6	34	27	<20	277	370	462	554	799	936	1074	1212	1345	1490	1629	5.44

* The specified sound level is applicable to straight connection without duct bend and commissioning damper.

Room attenuation = 4 dB.

**) = The water capacity is specified for a water flow of 0.064 l/s and can vary depending on the installation and how the ADC air deflectors are set.

***) = The water capacity is specified for a water flow of 0.125 l/s and can vary depending on the installation and how the ADC air deflectors are set.

Detailed acoustic data can be obtained by sizing with Swegon’s new ProSelect Web software available at Swegon’s home page: www.swegon.com.

Table 13. Data – Cooling. Sizing guide for the PACIFIC HF airflow variant with symmetric air distribution (50/50%), 100 Pa nozzle pressure

Capacity module	Nozzle setting		Airflow		Sound level, dB(A) *			Cooling capacity, primary air (W)				Cooling capacity of the water (W)							Pressure drop constant, air
	Length	Side										Connection (mm)			ΔT_l				
(mm)	50%	50%	(l/s)	(m³/h)	Ø100	Ø125	Ø160	6	8	10	12	6	7	8	9	10	11	12	k_{pl}
1100 **	4L	4L	12.2	43.9	<20	<20	<20	88	117	146	176	324	378	433	487	542	597	651	1.22
1100 **	4M	4M	23.7	85.3	23	<20	<20	171	228	284	341	401	471	542	613	684	755	827	2.37
1100 **	4H	4H	31.4	113.0	30	26	24	226	301	377	452	433	508	584	659	732	812	888	3.14
1600 **	6L	6L	18.2	65.5	<20	<20	<20	131	175	218	262	486	567	649	731	813	895	977	1.82
1600 **	6M	6M	35.5	127.8	32	25	<20	256	341	426	511	602	707	813	919	1026	1133	1241	3.55
1600 **	6H	6H	47	169.2	39	33	27	338	451	564	677	650	762	875	989	1098	1217	1332	4.7
2200 ***	8L	8L	24.3	87.5	24	<20	<20	175	233	292	350	661	772	883	994	1106	1218	1329	2.43
2200 ***	8M	8M	47.4	170.6	39	33	21	341	455	569	683	819	962	1106	1250	1395	1541	1688	4.74
2200 ***	8H	8H	62.7	225.7	48	42	30	451	602	752	903	884	1037	1191	1345	1494	1656	1812	6.27
2700 ***	10L	10L	30.4	109.4	28	22	<20	219	292	365	438	823	961	1100	1239	1377	1516	1656	3.04
2700 ***	10M	10M	59.2	213.1	46	40	25	426	568	710	852	1020	1198	1377	1557	1738	1920	2102	5.92
2700 ***	10H	10H	78.4	282.2	55	49	34	564	753	941	1129	1101	1291	1483	1676	1861	2063	2257	7.84

Table 14. Data – Cooling. Sizing guide for the PACIFIC HF airflow variant with asymmetric air distribution (30/70%), 100 Pa nozzle pressure

Capacity module	Nozzle setting		Airflow		Sound level, dB(A) *			Cooling capacity, primary air (W)				Cooling capacity of the water (W)							Pressure drop constant, air
	Length	Side										Connection (mm)			ΔT_l				
(mm)	30%	70%	(l/s)	(m³/h)	Ø100	Ø125	Ø160	6	8	10	12	6	7	8	9	10	11	12	k_{pl}
1100 **	4L	4H	21.8	78.5	24	22	22	157	209	262	314	403	472	541	611	679	751	822	2.18
1600 **	6L	6H	32.6	117.4	30	26	23	235	313	391	469	604	708	812	917	1019	1127	1233	3.26
2200 ***	8L	8H	43.5	156.6	37	31	25	313	418	522	626	823	965	1107	1250	1389	1537	1681	4.35
2700 ***	10L	10H	54.4	195.8	43	37	26	392	522	653	783	1023	1199	1376	1553	1726	1910	2089	5.44

* The specified sound level is applicable to straight connection without duct bend and commissioning damper.

Room attenuation = 4 dB.

**) = The water capacity is specified for a water flow of 0.064 l/s and can vary depending on the installation and how the ADC air deflectors are set.

***) = The water capacity is specified for a water flow of 0.125 l/s and can vary depending on the installation and how the ADC air deflectors are set.

Detailed acoustic data can be obtained by sizing with Swegon’s new ProSelect Web software available at Swegon’s home page: www.swegon.com.

Heating

Waterborne heating

The PACIFIC is as standard equipped with a coil containing two separate tube circuits. The first functions as a cooling circuit and the second as a heating circuit. When hot water circulates in the tube circuit, the recirculated air from the room is heated up in the coil, is then mixed with the primary air and is distributed to the room. The inlet flow temperature of the heating water should be kept as low as possible to minimise the temperature differential between the air at ceiling level and at floor level. The temperature stratification in the room will be negligible if the inlet flow temperature is kept at 40°C or lower. If the inlet flow temperature is up to the recommended max temperature (60°C), the stratification will be perceptible even if it normally is within the prescribed range.

In the majority of cases, the system will heat the room air to a satisfactory temperature. In order to achieve good operating temperature, other factors must be taken into account. The following factors are typical in this respect: Window dimensions, the U factor of the windows, the orientation of the room, the location of the occupants, etc. The quality and dimensions of the windows are also important with regard to possible cold down draughts. The windows used now-a-days are usually so well insulated that cold down draughts do not arise. Cold down draughts are especially likely to occur in the renovation of old buildings if the planner decides to keep the existing windows.

Electric heating

The PACIFIC variant with electric heating utilizes electric heating elements instead of hot water. The tubular heating elements, situated inside the heating water pipes of the coil, heat the circulated air that passes through the coil. Radiant heat constitutes only a small part of the total heating capacity

The PACIFIC with electric heating is available in two capacity variants, see the table below.

Variant	P (W)
X1	500
X2	1000

Recommendations for waterborne heating	
Max. permissible inlet flow temperature:	60° C
Min. permissible heating water flow:	0.013 l/s
Min. permissible nozzle pressure:	50 Pa

The heating capacity of the primary air for climate beam and supply air module

The following formula can be used for calculating the heating capacity of the primary air for the climate beam and the supply air module:

$$P_1 = q_1 \times 1.2 \times \Delta T_1$$

P_1 = heating capacity of the primary air (W)

q_1 = the primary airflow (l/s)

ΔT_1 = Temperature differential between the temperature of the primary air and the room temperature (K)

Sizing guides, Tables 16 to 27.

The tables are arranged according to airflow variant. Select the relevant table to suit your application on the basis of airflow, nozzle pressure and capacity requirements. The following can be read in the sizing guide:

Table guide

1. Length of the capacity module (mm)
2. Nozzle setting, left-hand and right-hand side
3. Primary airflow q_1 (l/s) och (m³/h)
4. Sound pressure level $L_p(A)$ for open damper with one air connection of Ø100, Ø125 or Ø160 (dB(A))
5. Waterborne heating capacity, P_v (W)
6. Pressure drop constant, air, k_{p1}

1	2		3	4			5							6	
	Length	Side		Connection	P_v							k_{p1}			
(mm)	Left-hand	Right-hand	(Pa)	(m ³ /h)	Ø100	Ø125	Ø160	5	10	15	20	25	30	35	
1100	RL	RL	1.6	55.2	<20	<20	<20	87	174	260	347	433	519	606	0.79
1100	RL	RR	1.5	27.0	<20	<20	<20	105	210	315	420	524	629	733	1.06
1100	RR	RR	12.7	45.7	<20	<20	<20	134	269	402	536	669	803	936	1.79
1600	RL	RL	0.4	32.2	<20	<20	<20	139	278	417	555	694	832	970	1.18
1600	RL	RR	11.2	45.3	<20	<20	<20	156	311	466	621	776	930	1085	1.58
1600	RR	RR	19	68.4	<20	<20	<20	199	398	597	795	993	1191	1389	2.69
2000	RL	RL	11.2	45.3	<20	<20	<20	177	354	530	707	883	1059	1235	1.57
2000	RL	RR	15	54.0	<20	<20	<20	216	432	648	864	1080	1296	1512	2.11
2000	RR	RR	25.4	91.4	21	<20	<20	274	547	820	1092	1364	1636	1908	3.18
2700	RL	RL	13.9	55.0	<20	<20	<20	217	435	651	868	1084	1300	1516	1.97
2700	RL	RR	18.7	62.3	<20	<20	<20	265	530	794	1057	1320	1584	1847	2.66
2700	RR	RR	31.7	116.1	27	<20	<20	339	677	1016	1352	1688	2025	2361	4.48

N.B.! The total heating capacity is the sum of the airborne and waterborne heating capacities. If the primary air temperature is lower than the room temperature, it causes negative impact on the total heating capacity.

Diagram 4. Heating capacity P_v (W) as a function of the change in temperature ΔT_v (K) and the heating water flow q_v (l/s). The capacity of the heating water can also be calculated by using the following formula:

$$P_v = 4186 \times q_v \times \Delta T_v$$

P_v = Heating capacity of the water (W)

q_v = Heating water flow (l/s)

ΔT_v = The temperature differential between the heating water supply and return (K).

Diagram 5. Pressure drop Δp_k (kPa) in the heating water circuit, as a function of the heating water flow q_v (l/s).

Diagram 6. Correction factor k for heating capacity P_v (W) as a function of heating the water flow q_k (l/s). Different water flows have a certain effect on the cooling capacity depending on how turbulent the water flow is. By checking calculated water flow against Diagram 6, the capacity specified in Tables 16 – 27 may need to be slightly adjusted up or down according to the following formula:

$$P_{corrected} (W) = P_{v (Tables 16-27)} \times k_{(Diagram 6)}$$

Diagram 4. Water flow – heating

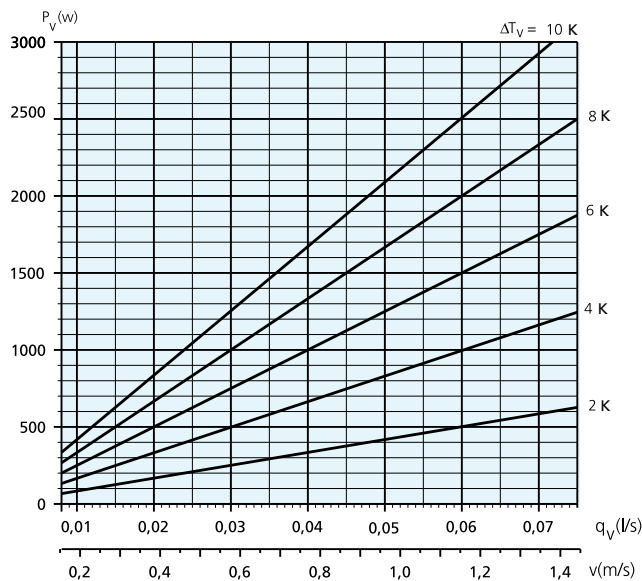
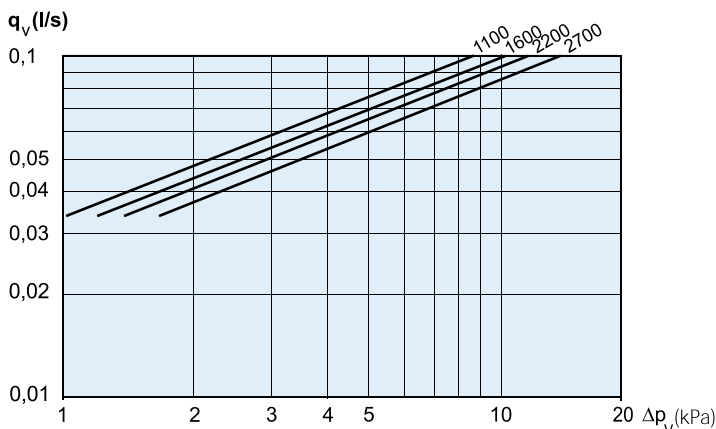

Diagram 5. Pressure drop – water flow, heating



Pressure drop for the heating water circuit

Use the following formula for calculating the pressure drop in the heating water circuit:

$$\Delta p_v = (q_v/k_{pv})^2 \text{ [kPa]}$$

Δp_v = pressure drop in heating circuit (kPa)

q_v = flow of heating water (l/s), read from Diagram 4.

k_{pv} = pressure drop constant read from Table 15.

Table 15. Pressure drop constants, heating circuit

Capacity module	= Pressure drop constant in the heating circuit
Length (mm)	k_{pv}
1100	0.0339
1600	0.0312
2200	0.0295
2700	0.0266

Diagram 6. Water flow – capacity correction, heating

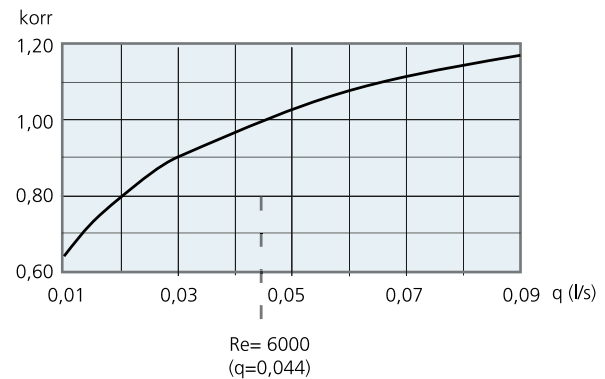

Table 16. Data – Heating. Sizing guide for the PACIFIC LF airflow variant with symmetric air distribution (50/50%), 50 Pa nozzle pressure

Capacity module	Nozzle setting		Airflow		Sound level, dB(A) *			Heating capacity, water (W) **							Pressure drop constant, air k_{pl}
Length	Side				Connection (mm)			ΔT_{mv}							
(mm)	50%	50%	(l/s)	(m ³ /h)	Ø100	Ø125	Ø160	5	10	15	20	25	30	35	
1100	4L	4L	5.9	21.2	<20	<20	<20	110	222	334	447	559	672	786	0.83
1100	4M	4M	9.5	34.2	<20	<20	<20	125	255	386	518	651	785	919	1.34
1100	4H	4H	12.7	45.7	<20	<20	<20	140	284	429	574	720	867	1014	1.79
1600	6L	6L	8.8	31.7	<20	<20	<20	165	333	501	670	839	1009	1178	1.25
1600	6M	6M	14.3	51.5	<20	<20	<20	188	382	579	777	977	1177	1379	2.02
1600	6H	6H	19	68.4	<20	<20	<20	211	426	643	861	1081	1301	1521	2.69
2200	8L	8L	11.7	42.1	<20	<20	<20	225	453	682	911	1141	1372	1603	1.66
2200	8M	8M	19	68.4	<20	<20	<20	255	519	787	1057	1329	1602	1876	2.69
2200	8H	8H	25.3	91.1	24	<20	<20	286	579	875	1172	1470	1769	2070	3.58
2700	10L	10L	14.7	52.9	<20	<20	<20	280	564	849	1135	1422	1709	1997	2.08
2700	10M	10M	23.8	85.7	23	<20	<20	318	647	980	1316	1655	1995	2336	3.36
2700	10H	10H	31.7	114.1	29	22	<20	357	722	1090	1460	1831	2204	2578	4.48

Table 17. Data – Heating. Sizing guide for the PACIFIC LF airflow variant with asymmetric air distribution (30/70%), 50 Pa nozzle pressure

Capacity module	Nozzle setting		Airflow		Sound level, dB(A) *			Heating capacity, water (W) **							Pressure drop constant, air k_{pl}
Length	Side				Connection (mm)			ΔT_{mv}							
(mm)	30%	70%	(l/s)	(m ³ /h)	Ø100	Ø125	Ø160	5	10	15	20	25	30	35	
1100	4L	4H	9.3	33.5	<20	<20	<20	132	266	402	538	674	811	949	1.31
1600	6L	6H	13.9	50.0	<20	<20	<20	195	394	595	797	999	1202	1406	1.97
2200	8L	8H	18.5	66.6	<20	<20	<20	267	539	814	1089	1366	1644	1922	2.62
2700	10L	10H	23.2	83.5	23	<20	<20	332	672	1013	1357	1701	2047	2393	3.28

* The specified sound level is applicable to straight connection without duct bend and commissioning damper.

Room attenuation = 4 dB.

** = The water capacity is specified for a water flow of 0.042 l/s and can vary depending on the installation and how the ADC air deflectors are set.

Detailed acoustic data can be obtained by sizing with Swegon’s new ProSelect Web software available at Swegon’s home page: www.swegon.com.

Table 18. Data – Heating. Sizing guide for the PACIFIC LF airflow variant with symmetric air distribution (50/50%), 100 Pa nozzle pressure

Capacity module	Nozzle setting		Airflow		Sound level, dB(A) *			Heating capacity, water (W) **							Pressure drop constant, air k_{pl}
	Length	Side			Connection (mm)			ΔT_{mv}							
(mm)	50%	50%	(l/s)	(m ³ /h)	Ø100	Ø125	Ø160	5	10	15	20	25	30	35	
1100	4L	4L	8.3	29.9	<20	<20	<20	135	273	412	551	691	831	971	0.83
1100	4M	4M	13.4	48.2	<20	<20	<20	152	307	463	620	778	936	1095	1.34
1100	4H	4H	17.9	64.4	<20	<20	<20	167	336	506	677	848	1019	1191	1.79
1600	6L	6L	12.5	45.0	<20	<20	<20	203	409	617	826	1036	1246	1457	1.25
1600	6M	6M	20.2	72.7	20	<20	<20	228	461	695	931	1167	1404	1642	2.02
1600	6H	6H	26.9	96.8	25	<20	<20	251	504	760	1015	1272	1529	1786	2.69
2200	8L	8L	16.6	59.8	<20	<20	<20	276	557	840	1124	1409	1695	1982	1.66
2200	8M	8M	26.9	96.8	26	20	<20	310	627	945	1266	1588	1910	2234	2.69
2200	8H	8H	35.8	128.9	32	25	<20	341	686	1033	1381	1730	2080	2430	3.58
2700	10L	10L	20.8	74.9	21	<20	<20	344	694	1046	1400	1755	2111	2468	2.08
2700	10M	10M	33.6	121.0	30	24	<20	386	780	1177	1577	1977	2379	2782	3.36
2700	10H	10H	44.8	161.3	38	31	20	425	855	1287	1720	2155	2590	3026	4.48

Table 19. Data – Heating. Sizing guide for the PACIFIC LF airflow variant with asymmetric air distribution (30/70%), 100 Pa nozzle pressure

Capacity module	Nozzle setting		Airflow		Sound level, dB(A) *			Heating capacity, water (W) **							Pressure drop constant, air k_{pl}
	Length	Side			Connection (mm)			ΔT_{mv}							
(mm)	30%	70%	(l/s)	(m ³ /h)	Ø100	Ø125	Ø160	5	10	15	20	25	30	35	
1100	4L	4H	13.1	47.2	<20	<20	<20	158	319	480	642	804	966	1129	1.31
1600	6L	6H	19.7	70.9	20	<20	<20	234	472	711	951	1191	1432	1673	1.97
2200	8L	8H	26.2	94.3	25	<20	<20	320	645	972	1300	1628	1958	2288	2.62
2700	10L	10H	32.8	118.1	30	23	<20	399	804	1211	1619	2028	2438	2849	3.28

* The specified sound level is applicable to straight connection without duct bend and commissioning damper.

Room attenuation = 4 dB.

** = The water capacity is specified for a water flow of 0.042 l/s and can vary depending on the installation and how the ADC air deflectors are set.

Detailed acoustic data can be obtained by sizing with Swegon’s new ProSelect Web software available at Swegon’s home page: www.swegon.com.

PACIFIC

Table 20. Data – Heating. Sizing guide for the PACIFIC MF airflow variant with symmetric air distribution (50/50%), 50 Pa nozzle pressure

Capacity module	Nozzle setting		Airflow		Sound level, dB(A) *			Heating capacity, water (W) **							Pressure drop constant, air k_{pl}
Length	Side		(l/s)	(m ³ /h)	Connection (mm)			ΔT_{mv}							
(mm)	50%	50%			Ø100	Ø125	Ø160	5	10	15	20	25	30	35	
1100	4L	4L	8.6	31.0	<20	<20	<20	126	254	382	510	639	768	897	1.22
1100	4M	4M	14.5	52.2	<20	<20	<20	144	293	444	596	749	897	1037	2.05
1100	4H	4H	18.5	66.6	22	21	20	154	329	495	656	817	976	1135	2.62
1600	6L	6L	12.9	46.4	<20	<20	<20	189	380	572	765	958	1152	1345	1.82
1600	6M	6M	21.7	78.1	21	<20	<20	216	440	666	894	1123	1346	1555	3.07
1600	6H	6H	27.9	100.4	27	23	22	230	493	743	985	1225	1464	1703	3.94
2200	8L	8L	17.2	61.9	<20	<20	<20	257	517	779	1041	1303	1567	1830	2.43
2200	8M	8M	29	104.4	27	21	<20	294	598	906	1216	1528	1831	2116	4.1
2200	8H	8H	37.1	133.6	33	28	24	313	671	1011	1340	1666	1992	2316	5.25
2700	10L	10L	21.5	77.4	22	<20	<20	320	644	970	1296	1623	1951	2279	3.04
2700	10M	10M	36.2	130.3	32	26	<20	367	745	1128	1514	1903	2280	2635	5.12
2700	10H	10H	46.4	167.0	39	33	25	390	836	1259	1668	2076	2481	2885	6.56

Table 21. Data – Heating. Sizing guide for the PACIFIC MF airflow variant with asymmetric air distribution (30/70%), 50 Pa nozzle pressure

Capacity module	Nozzle setting		Airflow		Sound level, dB(A) *			Heating capacity, water (W) **							Pressure drop constant, air k_{pl}
Length	Side		(l/s)	(m ³ /h)	Connection (mm)			ΔT_{mv}							
(mm)	30%	70%			Ø100	Ø125	Ø160	5	10	15	20	25	30	35	
1100	4L	4H	13.6	49.0	<20	<20	<20	145	305	459	610	760	910	1059	1.92
1600	6L	6H	20.4	73.4	22	20	20	217	458	689	915	1141	1365	1590	2.88
2200	8L	8H	27.2	97.9	27	22	21	295	622	937	1245	1551	1857	2162	3.84
2700	10L	10H	33.9	122.0	31	25	22	368	775	1168	1551	1932	2313	2693	4.8

* The specified sound level is applicable to straight connection without duct bend and commissioning damper.

Room attenuation = 4 dB.

** = The water capacity is specified for a water flow of 0.042 l/s and can vary depending on the installation and how the ADC air deflectors are set.

Detailed acoustic data can be obtained by sizing with Swegon’s new ProSelect Web software available at Swegon’s home page: www.swegon.com.

Table 22. Data – Heating. Sizing guide for the PACIFIC MF airflow variant with symmetric air distribution (50/50%), 100 Pa nozzle pressure

Capacity module	Nozzle setting		Airflow		Sound level, dB(A) *			Heating capacity, water (W) **							Pressure drop constant, air k_{pl}
Length	Side				Connection (mm)			ΔT_{mv}							
(mm)	50%	50%	(l/s)	(m ³ /h)	Ø100	Ø125	Ø160	5	10	15	20	25	30	35	
1100	4L	4L	12.2	43.9	<20	<20	<20	157	315	473	632	790	948	1107	1.22
1100	4M	4M	20.5	73.8	21	<20	<20	172	347	525	703	882	1057	1222	2.05
1100	4H	4H	26.2	94.3	29	28	27	182	387	585	777	968	1159	1349	2.62
1600	6L	6L	18.2	65.5	<20	<20	<20	236	473	710	947	1185	1422	1660	1.82
1600	6M	6M	30.7	110.5	28	22	<20	258	521	787	1054	1323	1585	1833	3.07
1600	6H	6H	39.4	141.8	35	31	29	273	581	877	1165	1452	1738	2024	3.94
2200	8L	8L	24.3	87.5	24	<20	<20	321	643	966	1289	1612	1935	2259	2.43
2200	8M	8M	41	147.6	35	29	21	351	709	1071	1434	1800	2156	2494	4.1
2200	8H	8H	52.5	189.0	43	37	31	372	791	1193	1585	1975	2365	2753	5.25
2700	10L	10L	30.4	109.4	28	22	<20	400	801	1203	1605	2007	2410	2813	3.04
2700	10M	10M	51.2	184.3	42	35	23	437	883	1333	1786	2242	2686	3106	5.12
2700	10H	10H	65.6	236.2	49	43	33	463	985	1486	1974	2460	2945	3429	6.56

Table 23. Data – Heating. Sizing guide for the PACIFIC MF airflow variant with asymmetric air distribution (30/70%), 100 Pa nozzle pressure

Capacity module	Nozzle setting		Airflow		Sound level, dB(A) *			Heating capacity, water (W) **							Pressure drop constant, air k_{pl}
Length	Side				Connection (mm)			ΔT_{mv}							
(mm)	30%	70%	(l/s)	(m ³ /h)	Ø100	Ø125	Ø160	5	10	15	20	25	30	35	
1100	4L	4H	19.2	69.1	25	24	24	174	364	549	730	911	1092	1272	1.92
1600	6L	6H	28.8	103.7	29	27	26	261	547	824	1096	1367	1638	1909	2.88
2200	8L	8H	38.4	138.2	35	30	28	356	744	1121	1491	1860	2228	2596	3.84
2700	10L	10H	48	172.8	40	34	29	443	927	1396	1857	2317	2776	3234	4.8

* The specified sound level is applicable to straight connection without duct bend and commissioning damper.

Room attenuation = 4 dB.

** = The water capacity is specified for a water flow of 0.042 l/s and can vary depending on the installation and how the ADC air deflectors are set.

Detailed acoustic data can be obtained by sizing with Swegon’s new ProSelect Web software available at Swegon’s home page: www.swegon.com.

PACIFIC

Table 24. Data – Heating. Sizing guide for the PACIFIC HF airflow variant with symmetric air distribution (50/50%), 50 Pa nozzle pressure

Capacity module	Nozzle setting		Airflow		Sound level, dB(A) *			Heating capacity, water (W) **							Pressure drop constant, air k_{pl}
	Length (mm)	Side			Connection (mm)			ΔT_{mv}							
		50%	50%	(l/s)	(m ³ /h)	Ø100	Ø125	Ø160	5	10	15	20	25	30	
1100	4L	4L	8.6	31.0	<20	<20	<20	125	249	373	497	620	743	867	1.22
1100	4M	4M	16.8	60.5	<20	<20	<20	142	290	440	592	745	899	1054	2.37
1100	4H	4H	22.2	79.9	22	<20	<20	158	322	488	656	826	996	1167	3.14
1600	6L	6L	12.9	46.4	<20	<20	<20	188	374	560	745	930	1115	1300	1.82
1600	6M	6M	25.1	90.4	24	<20	<20	213	435	660	888	1118	1348	1580	3.55
1600	6H	6H	33.2	119.5	30	24	<20	237	482	732	984	1238	1494	1750	4.7
2200	8L	8L	17.2	61.9	<20	<20	<20	255	509	761	1014	1266	1517	1769	2.43
2200	8M	8M	33.5	120.6	30	24	<20	290	592	898	1208	1520	1834	2150	4.74
2200	8H	8H	44.3	159.5	38	31	21	322	656	996	1339	1685	2032	2381	6.27
2700	10L	10L	21.5	77.4	22	<20	<20	318	634	948	1262	1576	1890	2203	3.04
2700	10M	10M	41.9	150.8	36	29	<20	361	737	1119	1505	1894	2285	2678	5.92
2700	10H	10H	55.4	199.4	44	38	24	401	817	1240	1668	2098	2531	2966	7.84

Table 25. Data – Heating. Sizing guide for the PACIFIC HF airflow variant with asymmetric air distribution (30/70%), 50 Pa nozzle pressure

Capacity module	Nozzle setting		Airflow		Sound level, dB(A) *			Heating capacity, water (W) **							Pressure drop constant, air k_{pl}
	Length (mm)	Side			Connection (mm)			ΔT_{mv}							
		30%	70%	(l/s)	(m ³ /h)	Ø100	Ø125	Ø160	5	10	15	20	25	30	
1100	4L	4H	15.4	55.4	<20	<20	<20	149	301	456	612	768	925	1083	2.18
1600	6L	6H	23.1	83.2	23	<20	<20	223	452	684	917	1152	1388	1625	3.26
2200	8L	8H	30.8	110.9	28	22	<20	304	616	932	1251	1571	1892	2215	4.35
2700	10L	10H	38.5	138.6	34	27	<20	378	766	1159	1554	1952	2352	2753	5.44

* The specified sound level is applicable to straight connection without duct bend and commissioning damper.

Room attenuation = 4 dB.

** = The water capacity is specified for a water flow of 0.042 l/s and can vary depending on the installation and how the ADC air deflectors are set.

Detailed acoustic data can be obtained by sizing with Swegon’s new ProSelect Web software available at Swegon’s home page: www.swegon.com.

Table 26. Data – Heating. Sizing guide for the PACIFIC HF airflow variant with symmetric air distribution (50/50%), 100 Pa nozzle pressure

Capacity module	Nozzle setting		Airflow		Sound level, dB(A) *			Heating capacity, water (W) **							Pressure drop constant, air k_{pl}
	Length (mm)	Side			Connection (mm)			ΔT_{mv}							
		50%	50%	(l/s)	(m ³ /h)	Ø100	Ø125	Ø160	5	10	15	20	25	30	
1100	4L	4L	12.2	43.9	<20	<20	<20	150	301	454	606	760	913	1067	1.22
1100	4M	4M	23.7	85.3	23	<20	<20	162	334	511	690	872	1055	1239	2.37
1100	4H	4H	31.4	113.0	30	26	24	175	364	558	755	956	1158	1363	3.14
1600	6L	6L	18.2	65.5	<20	<20	<20	224	452	680	910	1140	1370	1601	1.82
1600	6M	6M	35.5	127.8	32	25	<20	243	501	766	1035	1307	1582	1859	3.55
1600	6H	6H	47	169.2	39	33	27	263	545	836	1133	1434	1738	2044	4.7
2200	8L	8L	24.3	87.5	24	<20	<20	305	615	926	1238	1550	1864	2177	2.43
2200	8M	8M	47.4	170.6	39	33	21	330	682	1042	1408	1778	2152	2529	4.74
2200	8H	8H	62.7	225.7	48	42	30	357	742	1138	1541	1950	2364	2781	6.27
2700	10L	10L	30.4	109.4	28	22	<20	380	766	1153	1541	1931	2321	2712	3.04
2700	10M	10M	59.2	213.1	46	40	25	411	849	1298	1754	2215	2681	3150	5.92
2700	10H	10H	78.4	282.2	55	49	34	445	924	1417	1920	2429	2944	3464	7.84

Table 27. Data – Heating. Sizing guide for the PACIFIC HF airflow variant with asymmetric air distribution (30/70%), 100 Pa nozzle pressure

Capacity module	Nozzle setting		Airflow		Sound level, dB(A) *			Heating capacity, water (W) **							Pressure drop constant, air k_{pl}
	Length (mm)	Side			Connection (mm)			ΔT_{mv}							
		30%	70%	(l/s)	(m ³ /h)	Ø100	Ø125	Ø160	5	10	15	20	25	30	
1100	4L	4H	21.8	78.5	24	22	22	168	346	529	714	901	1090	1280	2.18
1600	6L	6H	32.6	117.4	30	26	23	252	519	793	1071	1352	1635	1920	3.26
2200	8L	8H	43.5	156.6	37	31	25	343	708	1081	1460	1843	2229	2618	4.35
2700	10L	10H	54.4	195.8	43	37	26	427	880	1343	1814	2290	2770	3254	5.44

* The specified sound level is applicable to straight connection without duct bend and commissioning damper.

Room attenuation = 4 dB.

** = The water capacity is specified for a water flow of 0.042 l/s and can vary depending on the installation and how the ADC air deflectors are set.

Detailed acoustic data can be obtained by sizing with Swegon’s new ProSelect Web software available at Swegon’s home page: www.swegon.com.

PACIFIC

Acoustics

Diagrams 7-9 show the total generated sound power (L_{Wtot} dB), as a function of the airflow and pressure drop across the commissioning damper. By correcting L_{Wtot} with the correction factors from Table 28, the sound power level can be obtained for each octave band ($L_w = L_{Wtot} + K_{ok}$).

Table 28. Sound power level for commissioning damper SYST CRPc, Correction factor, K_{ok}

Size	Mid-frequency (Octave band) Hz								
	CRPc 9	63	125	250	500	1000	2000	4000	8000
100	0	-2	-9	-15	-20	-25	-29	-29	-35
125	0	-2	-11	-17	-22	-25	-29	-29	-34
160	0	-2	-12	-16	-18	-21	-26	-26	-36

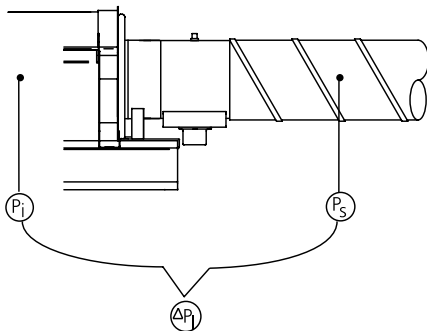

Figure 59. Pressure relationship, air

p_i = nozzle pressure (Pa), read from Tables 3-14 and 16-27.

p_s = duct pressure (Pa) upstream of unit and commissioning damper

Δp_i = damper commissioning range, for CRPc 9, see the Diagram for each size.

Diagram 7. Commissioning range, SYST CRPc 9-100 damper

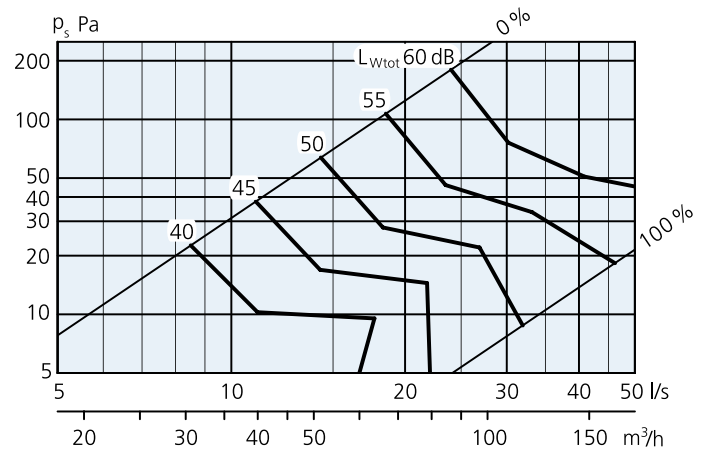

Diagram 8. Commissioning range, SYST CRPc 9-125 damper

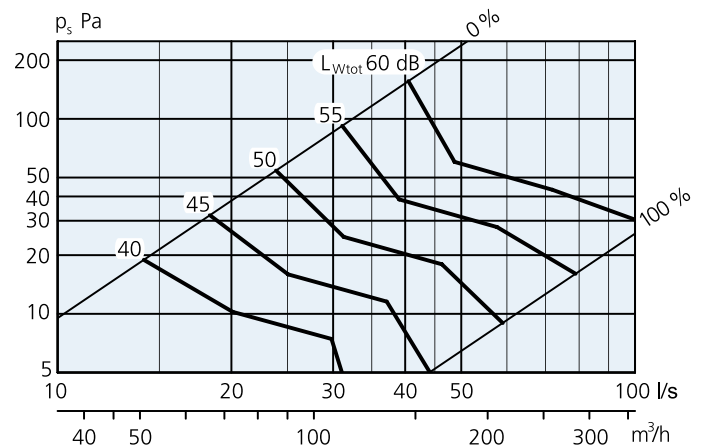
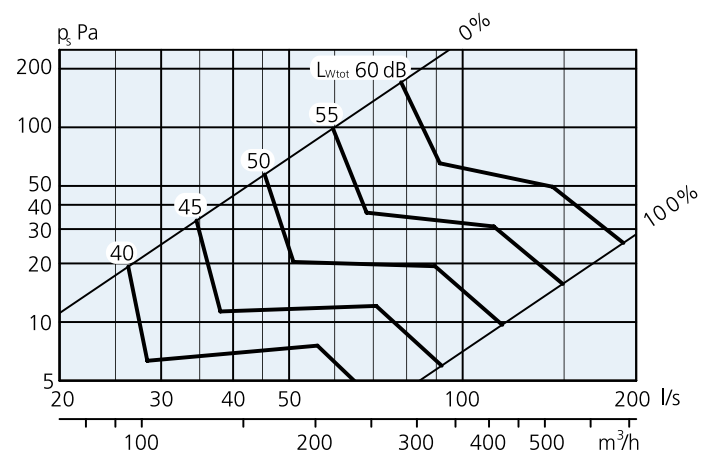

Diagram 9. Commissioning range, SYST CRPc 9-160 damper



Dimensions, climate beam

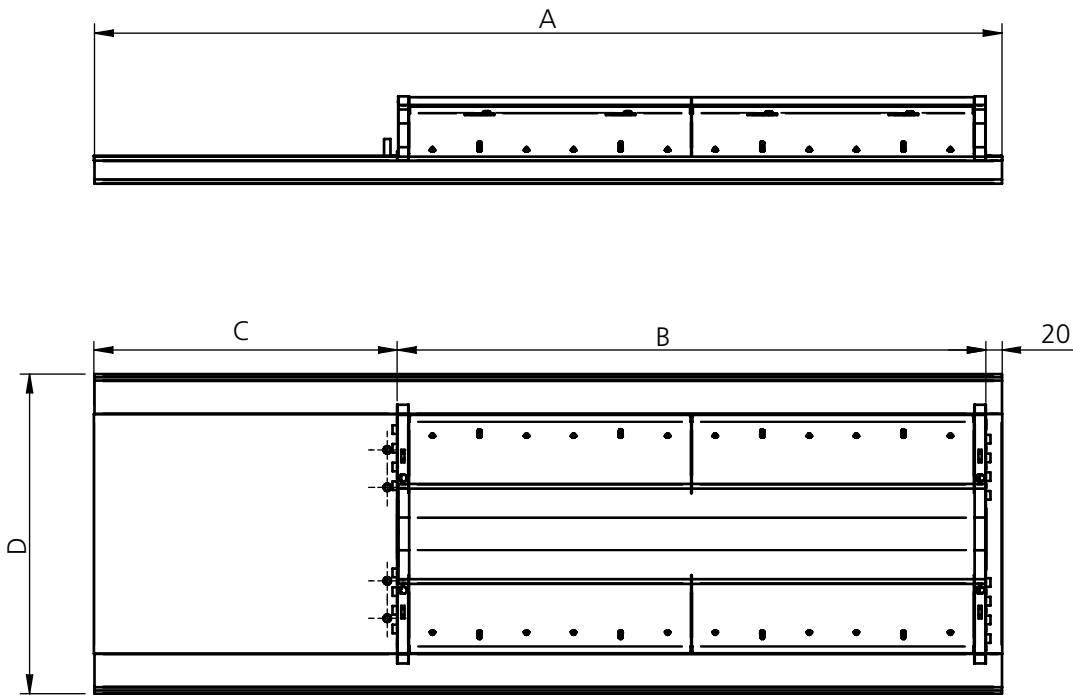

Figure 60. Dimensional drawing for the design module in T-bar with 600 mm centre-to-centre with capacity module in right-hand version – View from the side and from above

For design module in T-bar with 600 mm centre-to-centre

A	B	C	D
1194; 1715; 1794	1106	(1194)=68; (1715)=589; (1794)=668	594
1715; 1794; 2394	1635	(1715)=60; (1794)=139; (2394)=739	594
2394; 2994	2212	(2394)=162; (2994)=762	594
2994	2741	(2994)=233	594

For design module in T-bar with 625 mm centre-to-centre

A	B	C	D
1242; 1867	1106	(1242)=116; (1867)=741	617
1867; 2492	1635	(1867)=212; (2492)=837	617
2492	2212	(2492)=260	617

For design module in T-bar with 675 mm centre-to-centre

A	B	C	D
1342; 2017	1106	(1342)=216; (2017)=891	667
2017; 2692	1635	(2017)=362; (2692)=1037	667
2692	2212	(2692)=460	667

For design module in Clip-in ceiling and sheet metal ceiling coffers

A	B	C	D
1198; 1498; 1698; 1715; 1798	1106	(1198)=72; (1498)=372; (1698)=572; (1715)=589; (1798)=672	598
1698; 1715; 1798; 2398	1635	(1698)=43; (1715)=80; (1798)=143; (2398)=743	598
2398; 2998	2212	(2398)=166; (2998)=766	598
2998	2741	(2998)=237	598

Dimensions, climate beam

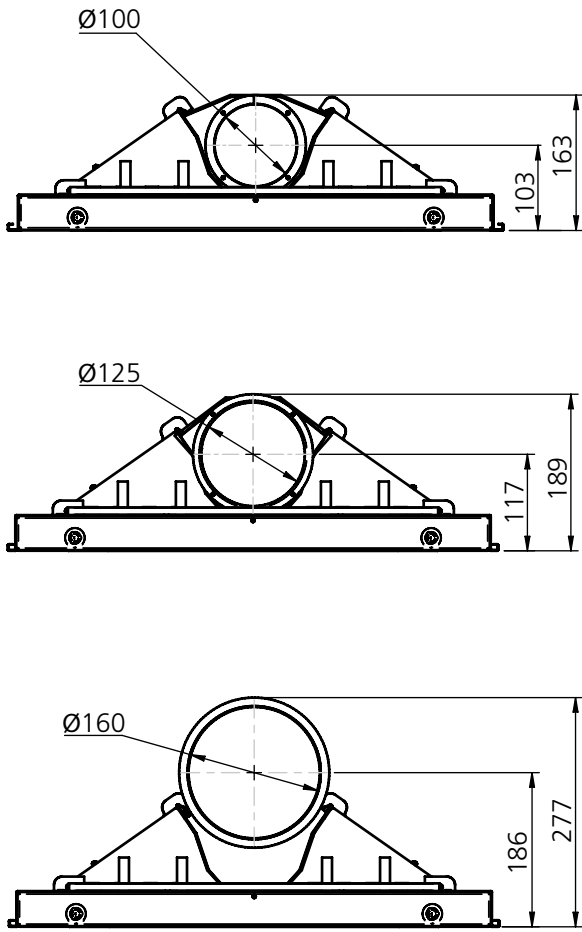

Figure 61. Dimensional drawing – air connection

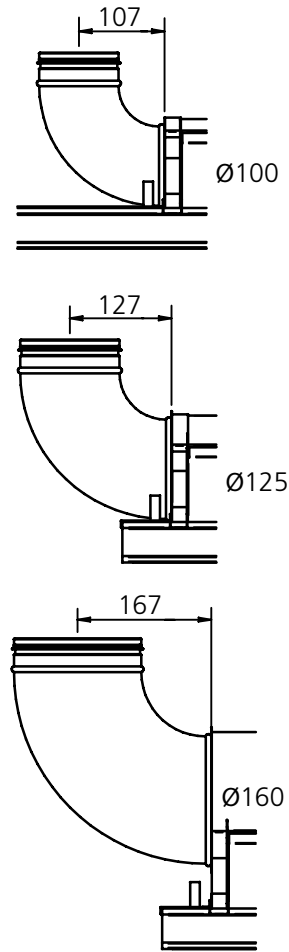

Figure 63. Dimensional drawing – vertical air connection with duct bend

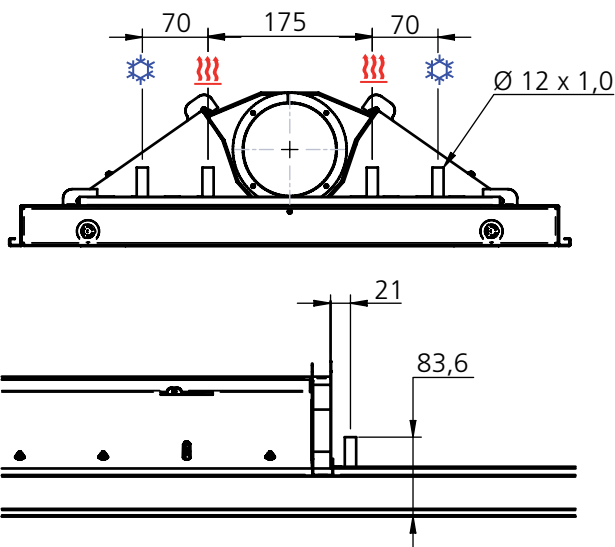

Figure 62. Dimensional drawing – water connections

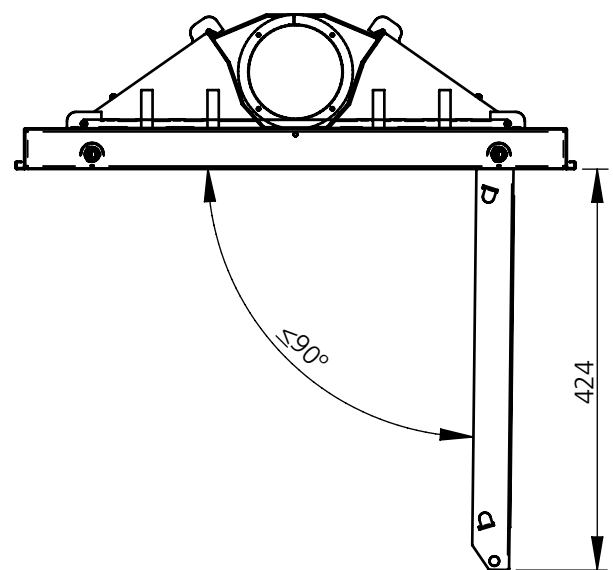

Figure 64. Dimensional drawing of hinged face plate

Dimensions, climate beam with additional SA/EA module



Figure 65. PACIFIC SA/EA, view from side and with capacity module in right-hand version.

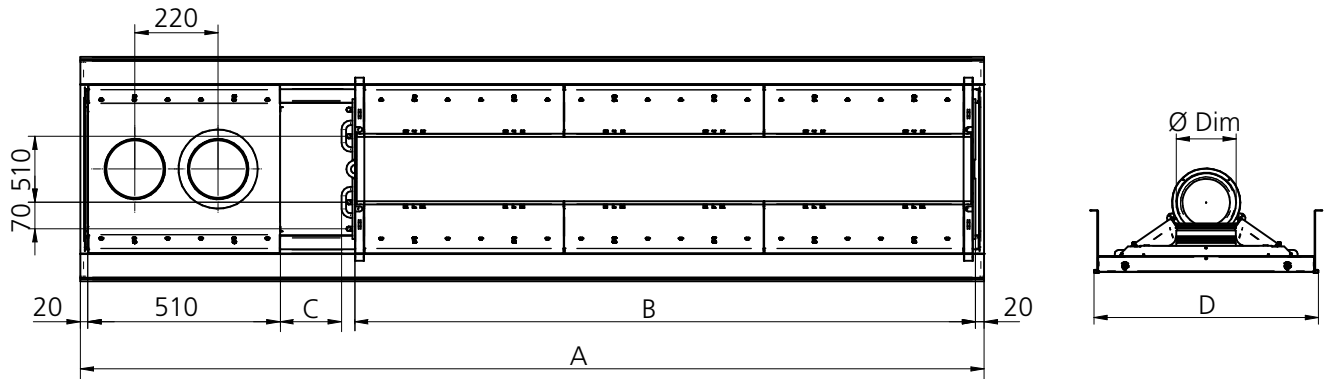

Figure 66. PACIFIC SA/EA, top view with capacity module in right-hand version and view showing end wall.

For design module in T-bar with 600 mm centre-to-centre

A	B	C	D
1794; 2394; 2994	1106	(1794)=91; (2394)=691; (2994)=1291	594
2394; 2994	1635	(2394)=162; (2994)=762	594
2994	2212	(2994)=175	594

For design module in T-bar with 625 mm centre-to-centre

A	B	C	D
1867; 2492;	1106	(1867)=164; (2492)=789	617
2492	1635	(2492)=260	617

For design module in T-bar with 675 mm centre-to-centre

A	B	C	D
2017; 2692	1106	(2017)=314; (2692)=989	667
2692	1635	(2692)=460	667

For design module in Clip-in ceiling and sheet metal ceiling coffers

A	B	C	D
1798; 2398; 2998	1106	(1798)=95; (2398)=695; (2998)=1295	598
2398; 2998	1635	(2398)=166; (2998)=766	598
2998	2212	(2998)=179	598

Dimensions, climate beam with additional SA/EA module with VAV kit

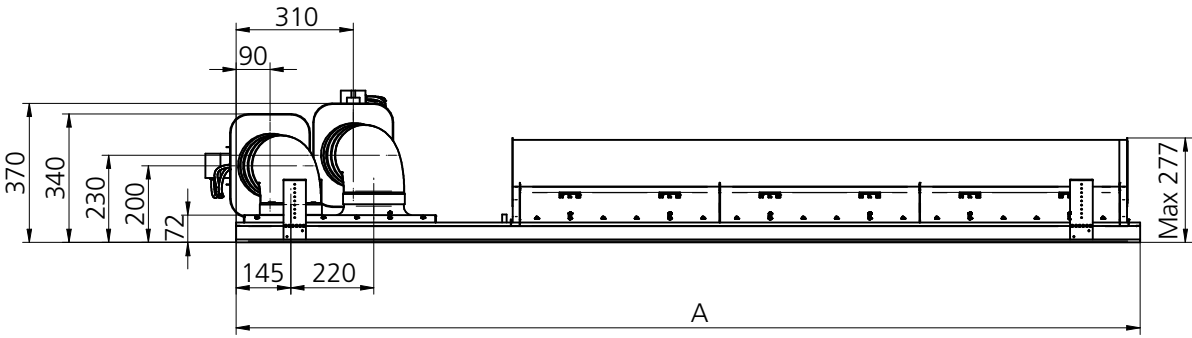

Figure 67. PACIFIC SA/EA with VAV kit, side view with capacity module in right-hand version.

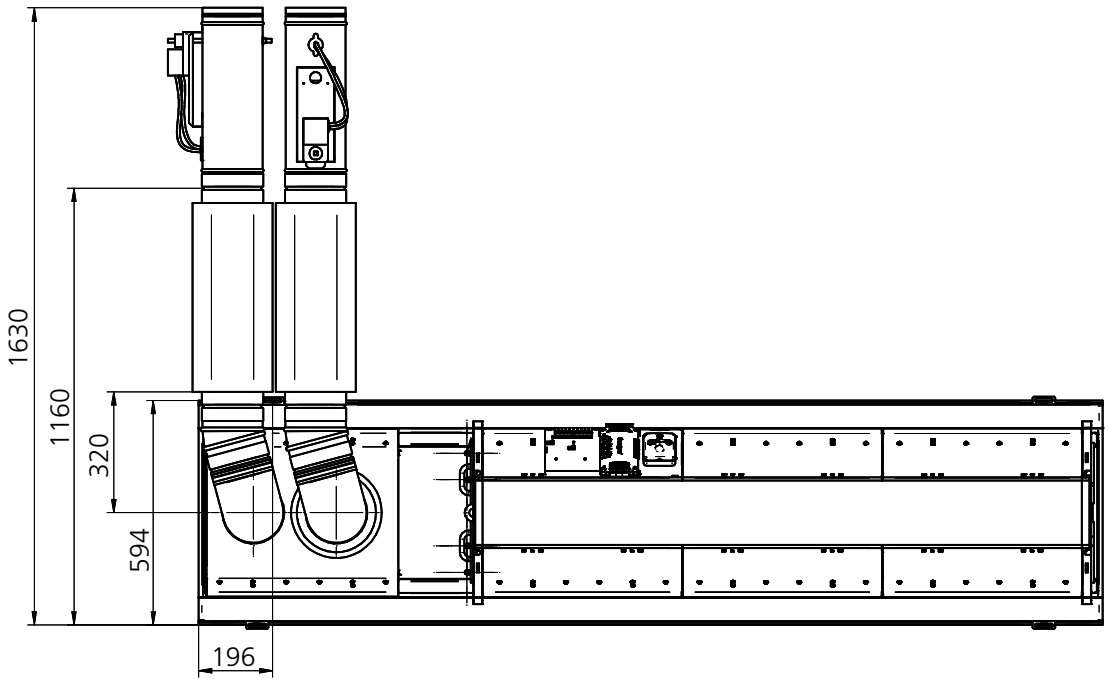

Figure 68. PACIFIC SA/EA with VAV kit, top view with capacity module in right-hand version.

Dimensions, climate beam with additional SA/EA module with CAV kit

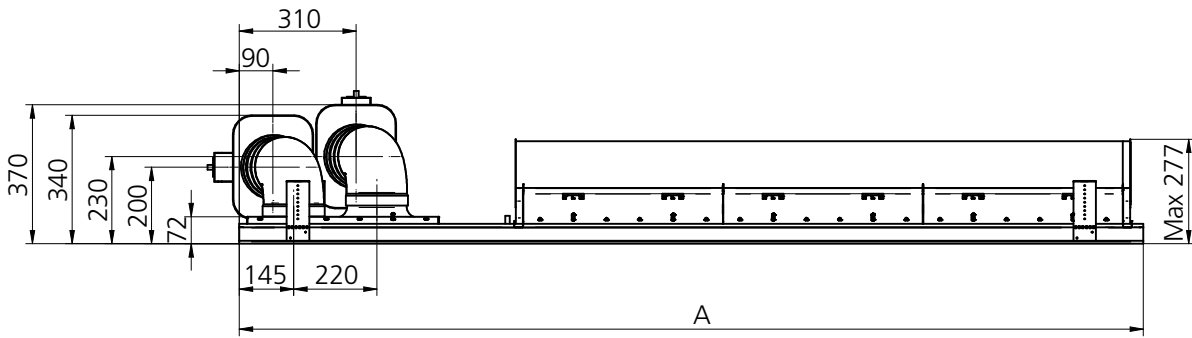

Figure 69. PACIFIC SA/EA with CAV kit, side view with capacity module in right-hand version.

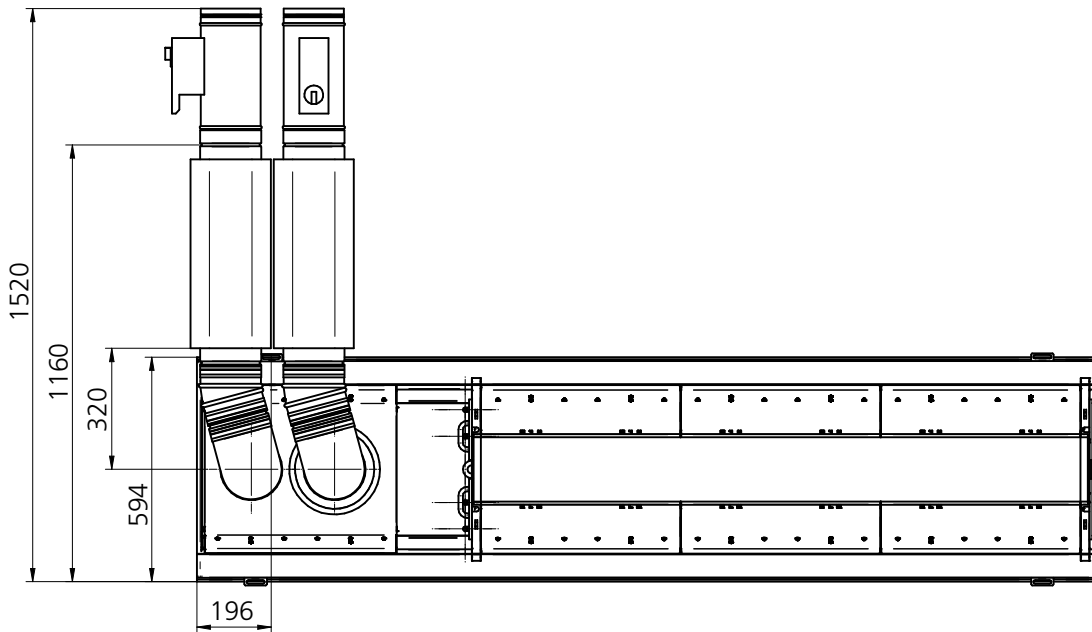

Figure 70. PACIFIC SA/EA with CAV kit, top view with capacity module in right-hand version.

PACIFIC

Ordering key

Swegon's PACIFIC climate beam for integrated installation in false ceilings, for cooling, heating and ventilation

T-bar with 600 mm centre-to-centre

PACIFIC	a	bbbb	cccc	594	ee	ff	ggg
Version							
Design module Length (mm): 1194, 1715, 1794, 2394, 2994							
Capacity module Length (mm): 1100, 1600, 2200, 2700* <i>*Not selectable for the SA/EA</i>							
Width (mm): 594							
B = Waterborne heating X1 = Electric heating 500 W X2 = Electric heating 1000 W							
Airflow variant: LF = Low flow MF = Medium flow HF = High flow							
Connection, air: Ø100, 125 and 160 (mm).							

T-bar with 625 mm centre-to-centre

PACIFIC	a	bbbb	cccc	617	ee	ff	ggg
Version							
Design module Length (mm): 1242, 1867, 2492							
Capacity module Length (mm): 1100, 1600, 2200							
Width (mm): 617							
B = Waterborne heating X1 = Electric heating 500 W X2 = Electric heating 1000 W							
Airflow variant: LF = Low flow MF = Medium flow HF = High flow							
Connection, air: Ø100, 125 and 160 (mm).							

T-bar with 675 mm centre-to-centre

PACIFIC	a	bbbb	cccc	667	ee	ff	ggg
Version							
Design module Length (mm): 1342, 2017, 2692							
Capacity module Length (mm): 1100, 1600, 2200							
Width (mm): 667							
B = Waterborne heating X1 = Electric heating 500 W X2 = Electric heating 1000 W							
Airflow variant: LF = Low flow MF = Medium flow HF = High flow							
Connection, air: Ø100, 125 and 160 (mm).							

Clip-in ceiling / sheet metal ceiling coffers

PACIFIC	a	bbbb	cccc	598	ee	ff	ggg
Version							
Design module Length (mm): 1198, 1498, 1698, 1715, 1798, 2398, 2998							
Capacity module Length (mm): 1100, 1600, 2200, 2700* <i>*Not selectable for the SA/EA</i>							
Width (mm): 598							
B = Waterborne heating X1 = Electric heating 500 W X2 = Electric heating 1000 W							
Airflow variant: LF = Low flow MF = Medium flow HF = High flow							
Connection, air: Ø100, 125 and 160 (mm).							

Examples of various connections to choose from

PACIFIC climate beam		
Air connection	Capacity module	Illustration, top view
Ø100-L Ø125-L Ø160-L	1100-L 1600-L 2200-L 2700-L	
Ø100-R Ø125-R Ø160-R	1100-L 1600-L 2200-L 2700-L	
Ø100-R Ø125-R Ø160-R	1100-R 1600-R 2200-R 2700-R	
Ø100-L Ø125-L Ø160-L	1100-R 1600-R 2200-R 2700-R	

Climate beam, PACIFIC SA/EA		
Air connection	Capacity module	Illustration, top view
Ø100-L Ø125-L Ø160-L	1100-L 1600-L 2200-L	
Ø100-R Ø125-R Ø160-R	1100-L 1600-L 2200-L	
Ø100-R Ø125-R Ø160-R	1100-R 1600-R 2200-R	
Ø100-L Ø125-L Ø160-L	1100-R 1600-R 2200-R	

Optional – Extra supply air or extract air

Additional module	SA/EA module
Supply and extract air module SA/EA	

Kit - Extra supply air	PACIFIC a T-AIR KIT	aaa
Supply air kit		
Type of kit		
CAV = Kit with manually adjustable damper		
VAV = Kit with motor-driven damper		

Kit – Extract air	PACIFIC a T-AIR KIT	aaa
Extract air kit		
Type of kit		
CAV = Kit with manually adjustable damper		
VAV = Kit with motor-driven damper		

Extract air register	PACIFIC a T-EA-EXC
EXC Extract air register	

Ordering example

Example 1:

One PACIFIC climate beam for a T-section grid system with 625 mm centre-to-centre, a beam width of 617 mm. The length of the design module is 2,492 mm and the length of the capacity module is 2,200 mm.

The unit should be the medium airflow variant and have a 125 mm dia. connection.

Designation: PACIFIC a-2492-2200-617-B-MF-125

Example 2:

One PACIFIC climate beam for a T-section grid system with 600 mm centre-to-centre, a beam width of 594 mm. The length of the design module is 2,394 mm and the client wants an inactive section and therefore selects a capacity module with a length of 1,600 mm.

The unit should be the low airflow variant and have a Ø100 mm connection.

Designation: PACIFIC a-2394-1600-594-B-LF-100

Flexible connection hose (1 item)	SYST FH F1	aaa-	12
Clamping ring coupling against pipe on both ends			
Length (mm): 300, 500 or 700			
Dimension: (Ø mm): 12			

Flexible connection hose (1 item)	SYST FH F20	aaa-	12
Quick coupling (push-on) on both ends			
Length (mm): 275, 475 or 675			
Dimension: (Ø mm): 12			

Flexible connection hose (1 item)	SYST FH F30	aaa-	12
Quick-fit coupling (push-on) on one end, G20ID sleeve nut on the other end			
Length (mm): 200, 400 or 600			
Dimension: (Ø mm): 12			

Assembly piece	SYST MS	aaaa-	b	M8
Length, threaded rod (mm): 200; 500; 1000				
1 = One threaded rod				
2 = Two threaded rods and a thread lock				

Plasterboard ceiling frame	PACIFIC T - FPB	aaaa	
Length (mm): 1194, 1794, 2394, 2994			

Accessories

Connection piece, air – insertion joint	SYST AD1	aaa	
Dimension (mm): 100; 125 or 160			

Connection piece, air	SYST CA	aaa	90
Dimension (mm): 100; 125 or 160			
90° duct bend			

Commissioning damper	SYST CRPc 9	aaa	
Dimension (mm): 100; 125 or 160			

Side connection kit, water	SYST CK1	aaa	
Air connection: Ø100/125 or 160			

Horizontal straight connection kit, water	SYST CK2		
---	----------	--	--

Venting connection	SYST AR-12		
--------------------	------------	--	--

Specification text

Example of a specification text conforming to VVS AMA Standard.

KB XX

Swegon's PACIFIC climate beam for integrated installation in false ceilings, with the following functions:

- Cooling
- Heating, water
- Heating, electric
- Ventilation
- Additional SA, EA or SA/EA module with VAV or CAV function.
- ADC comfort guarantee feature
- VariFlow for simple adjustment of the airflows
- Enclosed version for circulating air
- Cleanable
- Fixed measurement tapping with hose
- Easily removable face plate for access to coil
- Painted in standard shade of white (RAL 9003), gloss rating: 30±6%
- Fits standard T-section grid system with modular dim.: 600 mm. 24 mm T-profiled section
- Contractor demarcation at the connection points for water and air according to dimensional drawing.
- At the connection points, the pipework contractor connects to Ø12 mm plain pipe end (cooling) or 12 mm dia. plain pipe end (heating). The ventilation contractor connects the ducting to the beam across a Ø100 mm, Ø125 mm or Ø160 mm dia. connection piece.
- The pipework contractor fills, bleeds, tests the pressure and assumes responsibility for the design water flows reaching each branch of the system and the climate beam.
- The ventilation contractor adjusts the design airflows.

Size:

KB XX-1 PACIFIC a bbbb/cccc - ddd - ee - ff - gg xx pc.

KB XX-2 PACIFIC a bbbb/cccc - ddd - ee - ff - gg xx pc.

etc.

Accessories:

- Kit, Extra supply air, PACIFIC a T-AIR-KIT, xx pc.
- Kit, Extract air, PACIFIC a T-AIR-KIT, xx pc.
- Extract air register, EXC, PACIFIC a T-EA-EXC, xx pc.
- Connection piece, air (insertion joint) SYST AD1-100 xx pc.
- Connection piece (90° duct bend), SYST CA 100-90 xx pc.
- Commissioning damper, SYST CRPc 9-100, xx pc..
- Connection piece, air (insertion joint) SYST AD1-125 xx pc.
- Connection piece (90° duct bend), SYST CA 125-90 xx pc.
- Commissioning damper, SYST CRPc 9-125, xx pc..
- Connection piece, air (insertion joint) SYST AD1-160 xx pc.
- Connection piece (90° duct bend), SYST CA 160-90 xx pc.
- Commissioning damper, SYST CRPc 9-160, xx pc..
- Side connection kit, water, SYST CK1-160 xx pc.
- Horizontal connection kit, water, SYST CK2 xx pc.
- Venting nipple SYST AR-12 xx pc.
- Flexible connection hose, SYST FH F1 aaa - 12 xx pc.
- Flexible connection hose, SYST FH F20 aaa - 12 xx pc.
- Flexible connection hose, SYST FH F30 aaa - 12 xx pc.
- Assembly piece SYST MS aaaa - b - M8 xx pc.
- plasterboard frame, PACIFIC T-FPB aaaa xx pc.
- Control equipment, see separate product information section in catalogue on water-based indoor climate systems, or at Swegon's website: www.swegon.com