

# FRB

Exposed passive chilled beam for suspended installation



FRB

## FRB

- ▶ FRB is a passive chilled beam for comfort cooling especially designed for visible/suspended installation in the room.
- ▶ High cooling capacity, even when there is a large difference in temperature between the coolant supply and the return temperature.
- ▶ A small, compact unit available in two widths.

## Key figures

### Cooling capacity

Size	P <sub>k</sub> (BTU/hrft)	ΔT <sub>mk</sub> (°F)
FRB 430	262	18
FRB 290	166	18

Length: From 75 to 154 in.

Width: 11 and 17 in.

Height: 5 in.



### Function

- Cooling

### Application

Suitable for all types of rooms that are cooled with a water based system:

- Offices (cellular offices and open)
- Hotels
- Class rooms
- Conference rooms
- Computer rooms
- Restaurants
- Banks
- Shops

### Advantages of FRB

- FRB is a very compact passive chilled beam. The low build-in height, choice of two widths, plus the fact that water is used as an energy transfer medium, means that the system requires a minimum of space.
- The high performance of this chilled beam means that it maintains high cooling capacity even at low  $Dt_{mk}$ , thus making it possible to increase the temperature difference between the flow and return. This gives the product good operating properties and high output efficiency.
- FRB is specially designed for suspended installation. The softened form of the beam means that it blends into the room environments in a natural way.
- FRB is particularly suitable for areas where heating and ventilation have already been installed, and require supplementary cooling.
- The system has no moving parts, generates no sound and is maintenance free.
- Connection details and valves are easily covered by a neat connection cover. The cover is mounted after that the beam is hanged and connected.

## Installation

FRB is designed for suspended installation.

Connection dimensions: Cooling (water): plain pipe ends or available 1/2" NPT.

### Suspension:

The units are equipped with mounting brackets designed for the SYST MS assembly set. The assembly sets are available in various variants to fit various suspended distances. The SYST MS must be specified and ordered separately.

## Standard product range held in stock

For particulars of the standard product range held in stock, visit [www.swegon.com](http://www.swegon.com).

## Range available on order

Width: 11 and 17 in.

Length: From 75 to 154 in increments of 12 in.

Colour: RAL 9010 gloss value 30+6%.

Design: With horizontal connection at the end-H or with the 12 in. connection area and internal connections-I.

## Function

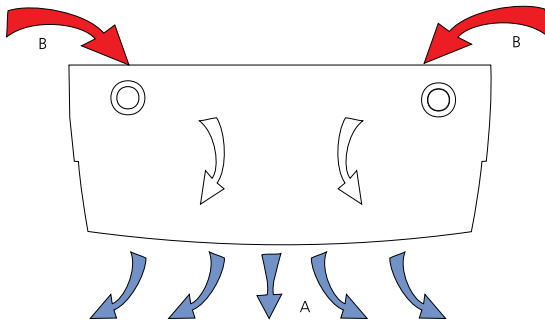

Figure 1. Cooling. A = chilled air; B = warm room air.

## Assembly

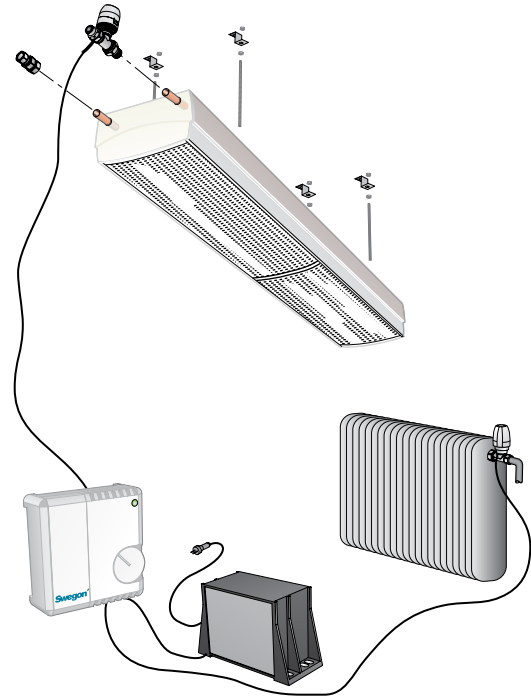

Figure 2. Assembly.



Figure 3. Maintenance, sliding lower section.

## Special models

### Color

FRB is available on request in optional colors.

## Accessories

### Connection cover

The connection cover is fitted over the extended section of the chilled beam to conceal the pipe connections.

**Flexible connection hose**

Flexible hose with either quick connect or compression couplings.

**MS assembly set**

The assembly set for suspended installation consists of threaded rods of different length (8, 20, and 40 in.). Specify the length desired to meet site design requirements. The set also contains plastic sleeves to make the installation more attractive. The necessary ceiling brackets, nuts and washers are included in the supply.

**Extended connection pipe**

Pipe extension with compression ring coupling at one end for connection to the chilled beam. Supplied in pairs.

**Recommended limit values - Water**

Max. recommended working pressure:	201 ftWG
Max. recommended test pressure when testing the completed installation:	301 ftWG
Min. cooling water flow:	.48 GPM
Temperate increase cooling water:	3.6-9 °F
Min. supply temperature:	Should always be selected so that the system works without condensation.

Ensures that any air in the system can be expelled at the minimum water flow rate per circuit.

**Accessories**

Figure 4. Cover for connection against a wall.

1. Dismount the plastic end cover of the beam.
2. Fasten the wall attachment to the wall.
3. Insert the attachment plate on the top of the beam.
4. Fit the cover into the wall attachment and to the beam. Lock the position of the cover with the attachment plate by pushing the plate back.

## Technical Data

### Cooling

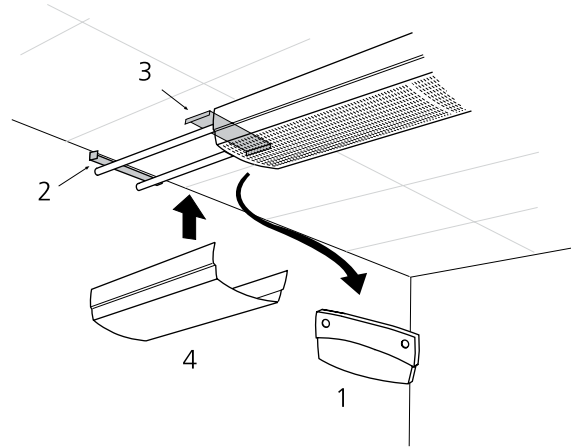
The cooling capacities have been measured in conformance with EN 15116 Standard. Detailed performance data is available online selection software ProSelect, available at [www.swegon.com](http://www.swegon.com).



The following can be read in the Proselect:

- The length of the climate beam (inches)
- The primary airflow (CFM)
- The noise level for an open damper, with ADC
- Nozzle pressure (inWG)
- Airborne cooling capacity (BTU)
- Waterborne cooling capacity (BTU)

N.B. The total cooling capacity is the sum of the airborne and waterborne cooling capacities.

**Diagram 1.** FRB 290 - the relation between the circulation air openings and the output. The cooling capacity is corrected according to the size of the circulation openings as per the following  $P = P_{ProSelect} \cdot K_s$ .

**Diagram 2.** FRB 430 - the relation between the circulation air openings and the output. The cooling capacity is corrected according to the size of the circulation openings as per the following  $P = P_{ProSelect} \cdot K_s$ .

For capacity, refer to ProSelect.

**Diagram 1. FRB 290, reduction factor**

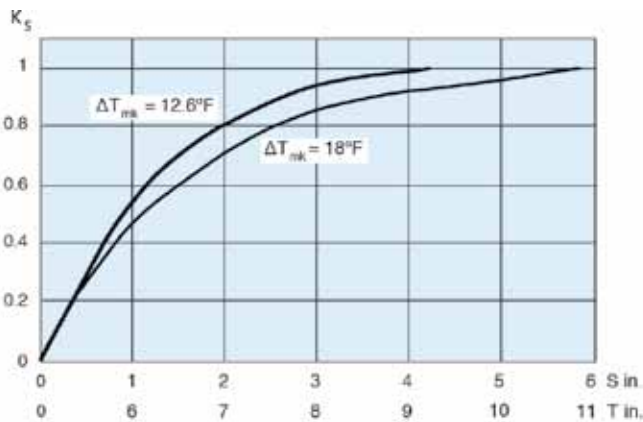

**Diagram 2. FRB 430, reduction factor**

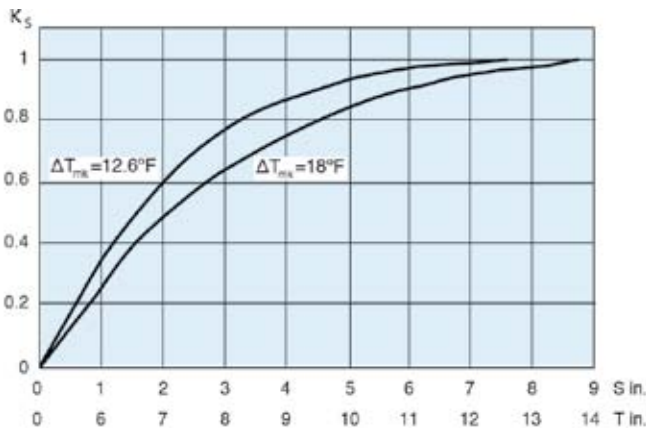

S = Ceiling spacing

T = Total installation height including circulation air gap

k<sub>s</sub> = Effect reduction factor

The ceiling spacing is valid when there is circulation air from two sides. When there is circulation air only from one side the same effect reduction factors is applied if the ceiling spacing is increased 1.5 times.

**Circulation air openings**

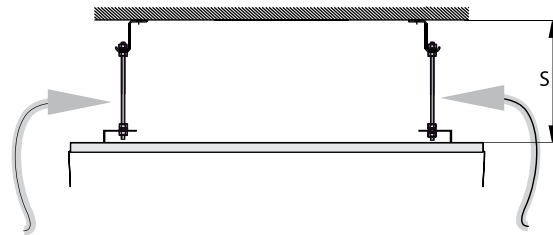

Figure 5. Circulation air openings. With circulation air measurement from one side only the opening "S" is increased by 1.5 times.

## Dimensions

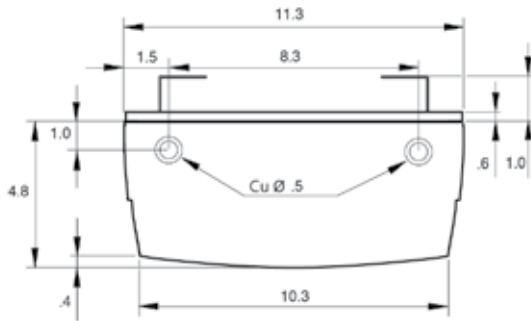

Figure 6. FRB 290, end view.

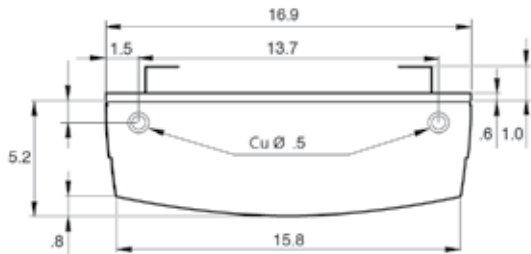

Figure 7. FRB 430, end view.

### Length FRB

Nominal size FRB 290 and FRB 430 (m) :	47, 59, 71, 83, 94, 106, 118, 130, 142 and 154 inches
Length FRB 290	Nominal - 1 in. (+.2/-0.8)
Length FRB 430	Nominal - .5 in. (+.2/-0.8)
Size of lower section's subdivision $L_u = L/2$	

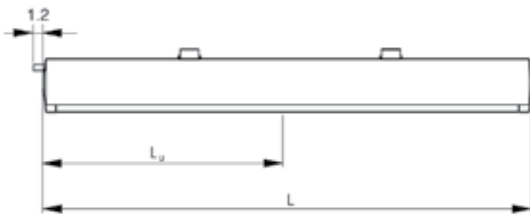

Figure 8. Connection -H, side view.  
 $L$  = length FRB  
 $L_u$  = length of lower section's subdivision

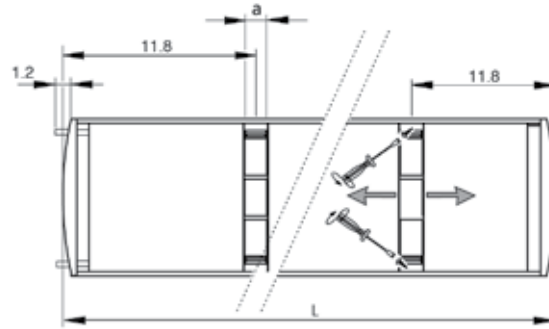

Figure 9. Horizontal connection at the end -H, top view.  
 $a$  = adjustment allowance suspension fittings 1.7 in.

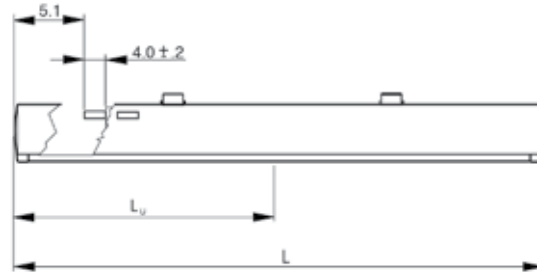

Figure 10. Connection -I, side view.  
 $L$  = length FRB  
 $L_u$  = length of lower section's subdivision

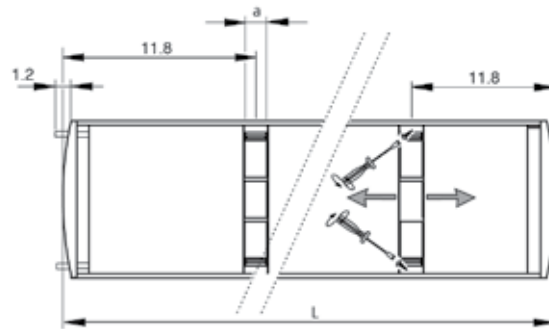

Figure 11. Connection -I, top view.  
 $a$  = adjustment allowance suspension fittings 1.7 in.

## Installation measurements

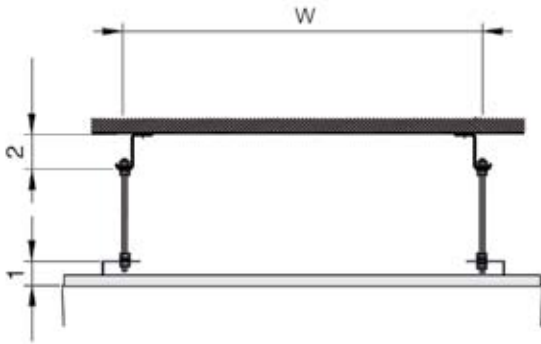

Figure 12. Assembly fittings SYST MS.

FRB 290:  $W = 7.4$  in.

FRB 430:  $W = 12.9$  in.

## Limits of contract

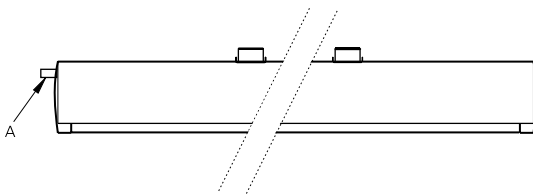

Figure 13. Connection, side view.

A = cooling: the plumbing contractor makes connections to pipe.

## Weight

Weight per foot FRB 290	
Dry weight	3.4 lbs/ft
Weight, water-filled	3.7 lbs/ft

Weight per foot FRB 430	
Dry weight	4.9 lbs/ft
Weight, water-filled	5.4 lbs/ft

## Specification

Cooling system type FRB for cooling.

The units are supplied enameled in Swegon white standard colour RAL 9010 gloss value  $30 \pm 6\%$ .

## Limits of contract

Swegon limits of contract are at the connection points for water (in accordance with the **Figure 13** under Dimensions - Limits of contract/connection points). At these connection points the plumbing contractor connects to plain pipe ends, fills the system, vents and carries out pressure testing.

The units are supplied exclusive of assembly kits. These are to be ordered separately.



## Specification

### Product

<b>FRB</b>	b-	aaa-	bbb-	c
Version:				
Size:				
290 mm = 12 in.				
430 mm = 17 in.				
Length:				
47, 59, 71, 83, 94, 106, 118, 130, 142, 154 in.				
Connection:				
H = horizontal connection outside the end				
I = connection section, inside				

### Accessories

Connection cover	FRB b-	T-KA	aaa-	bbb
Version				
Type:				
Size:				
290 and 430				
Length:				
5, 12, 20 and 28 in.				

Loose endplates	FRBT GL	aa-	bbb
UH = without hole			
MH = with hole			
Size:			
290, 430			

Extension pipe, 2	SYST FR	aaa
Length:		
12 or 17 in.		

Assembly set	SYST MS	aaaa-	b-	RAL9010
For suspended installation				
Length drop rod:				
8, 20, 40 in.				
1 = only the drop rod				
2 = double drop rods with tread lock				

Flexible connection hose (1)	SYST FH F1	aaa
Clamping ring coupling against pipe on both ends		
Length: 12, 20, 28 in.		
Dimension (Ø) 0.5 in.		

Flexible connection hose (1)	SYST FH F20	aaa
Quick-fit coupling (push-on) against pipe on both ends		
Length: 11, 19, 27 in.		
Dimension (Ø) 0.5 in.		

Flexible connection hose (1)	SYST FH F30	aaa
Quick-fit coupling (push-on) against pipe on one end, 1/2-inch NPT sleeve nut on the other end		
Length: 8, 16, 24 in.		
Dimension (Ø) 0.5 in.		