

Swegon **CASA**[®] W100 EC, version B

Instructions for Installation, Operation and Maintenance



Contents

Instructions for Installation, Operation and Maintenance

1. Important information	3	5.7.6 Fan speeds.....	14
2. Quick Guide	4	5.7.7 Shutting down.....	14
2.1 Control from the Premium cooker hood.....	5	5.7.8 Factory settings.....	14
2.2 Control from the Premium control panel	5	5.7.9 Controller	14
2.2.1 Fireplace switch function.....	5	5.7.10 Functions.....	14
2.2.2 Selection of fan speed.....	5	5.7.11 Electric air heater	14
2.2.3 Menu/Installation and service	5	6. Servicing	15
2.2.4 Signal lamp.....	5	6.1 Service reminder	15
3. General Description	6	6.2 To open the ventilation unit	15
3.1 Basic functions.....	6	6.3 Filter change	15
3.1.1 Fans.....	6	6.4 Other servicing.....	15
2.3 Filter change	6	7. Alarms and troubleshooting	16
2.3.1 Extract and outdoor air filter	6	7.1 Alarms.....	16
2.3.2 Supply air filter.....	6	7.1.1 Alarms from a Premium control panel	16
2.4 Service reminder	6	7.2 Troubleshooting:	16
2.5. Alarm	6	7.2.1 The supply air is not sufficiently heated	16
3.1.2 Temperature	7	8. List of components	17
3.1.3 Protective functions	7	9. Technical details	18
3.2 Optional equipment – automated control equipment.....	7	9.1 Fan Diagrams.....	18
4. Installation	8	9.2 Acoustic data.....	19
4.1 General.....	8	9.3 Connection outputs.....	20
4.2 Ventilation unit installation site	8	9.4 Sizing of the water-heated air heater	21
4.2.1 Wall mounting.....	8	9.5 Pressure loss in the air heater for reheat.....	21
4.2.2 To install the ceiling mounting frame.....	9	9.6 Electrical wiring diagram	22
4.2.3 Installation in ceiling mounting frame	9	9.6.1 Ventilation unit	22
4.3 Condensate discharge.....	10	9.6.2 Control functions with optional items of equipment ...	23
4.4 To connect the cooker hood.....	10	9.7 Control diagram	26
4.5 Electric and control cables.....	10	9.7.1 W100 EC	26
4.6 Ducts.....	10	9.7.2 W100 EC Econo.....	27
4.7 To seal around duct penetration collars	11	9.8 Dimensions.....	28
4.8 Installation of the Econo model.....	11	9.8.1 Ventilation unit codes	28
5. Application	12	9.8.2 Weight	28
5.1 To set the airflows.....	12	9.8.3 Optional items of equipment for installation	28
5.2 Bypass past the heat exchanger	12	10. Commissioning	29
5.3 Premium cooker hood.....	12	Warranty Conditions	31
5.4 Premium control panel.....	12	EG Compliancy Declaration	32
5.5 Start menu.....	13		
5.5.1 Fireplace switch function.....	13		
5.5.2 Fan speed	13		
5.6 Main menu	13		
5.6.1 Language.....	13		
5.6.2 Installation and service	13		
5.6.3 Reheat (not on the Econo models)	13		
5.6.4 Clock.....	13		
5.6.5 Base display	13		
5.6.6 Shutting down.....	13		
5.6.7 Fireplace function	13		
5.6.8 One-week timer.....	13		
5.6.9 Ventilation unit model.....	13		
5.7 Installation and service	13		
5.7.1 Alarm/Service reminder	14		
5.7.2 Clock.....	14		
5.7.3 Temperature	14		
5.7.4 Measurements	14		
5.7.5 Control functions	14		

N.B.! The manual was originally written in Finnish.

1. Important information



Qualified personnel only

The installation work, the entering of settings and commissioning should be carried out by qualified personnel only.

Standards and requirements

The pertinent national standards and regulations dealing with installation, the entering of settings and commissioning must be followed if the equipment is to operate correctly.

You will find the document entitled "Project planning instructions for ventilation" at the www.swegon.com/casa web address, in which requirements on electric power, sound, airflows and duct system are presented. Each country has specific national requirements which must be observed.

Measurements and electrical work

Isolate the ventilation unit from the electrical supply grid if you carry out voltage tests, electrical insulation resistance or other similar measurements or electrical work that could damage sensitive electrical equipment.

Surge protection

Swegon recommends that all ventilation units equipped with Premium automatic control be equipped with surge protection.

Earth fault circuit breaker

It is not sure that an earth fault circuit breaker will operate correctly in combination with the cooker hood, since the cooker hood's control equipment could give rise to

leakage currents. Comply with local electrical safety regulations when you install electrical equipment.

To open the ventilation unit for service

Always ensure that the ventilation unit's power supply has been isolated before you open the inspection door! Wait a few minutes before you open the inspection door of the ventilation unit so that the fans have time to stop and air heaters, if fitted, have time to cool down.

There are no components inside the electrical equipment cabinet that can be serviced by the user. Servicing of these parts must be entrusted to service personnel. Do not restart the ventilation unit before you've identified the cause of the fault and service personnel have serviced the ventilation unit.

The Econo models

The Econo model ventilation unit should be equipped with a shut-off damper so that the water-heated air heater will not freeze in the event of a power failure.

Separate extract air (kitchen bypass)

Keep in mind that the separate extract air duct runs past the heat exchanger and should only be used while you are cooking food. The ordinary extract air register in the kitchen should be connected to the ventilation unit's extract air duct.

2. Quick Guide

Important information!

Airflows

The air in the home should be changed at a continuous and sufficient rate to ensure a pleasant indoor climate and avoid damage to building elements caused by dampness. The ventilation unit should be stopped only while service work is in progress.

The airflow from the ventilation unit can be controlled to generate the various airflows from a Premium control panel or a Premium cooker hood.

- Away = a low rate of airflow, which can be utilized when no one is in the home and there is no need for the same ventilation rate normally in use, e.g. for moisture control.
- Home = normal airflow.
- Boost = a high rate of airflow, used in connection with cooking, taking a sauna bath, showering, drying laundry and similar activities.

On the models with electric reheating, the Away/Home operating modes and the supply air temperature can be controlled with the ventilation unit's built-in weekly timer. The operating mode can always be changed from a Premium control panel or a Premium cooker hood.

A low airflow when the home is unoccupied means economical operation. This saves on fan energy and the home heating system does not have to heat as much air during the cold season.

The most important function of the ventilation system is to ensure that the indoor air will be continuously fresh and to remove impurities and moisture from the air. You should therefore make an appraisal of whether a low airflow is sufficient while the home is unoccupied. The low airflow mode must absolutely

not be used when someone is in the home.

To ensure that the ventilation unit is used in the right way, you should equip the system with a humidity sensor, if you have begun using the Away mode.

If the load on the home is greater than you've anticipated, then you should increase the normal airflow to a correspondingly higher rate.

Drying laundry

A tumbler dryer of extract air type or a drying cabinet must not be connected to the system due to the high moisture content in the air leaving them. We recommend a condensing tumbler dryer without duct connection.

Freeze protection

During periods of cold weather, the heat exchanger is liable to freeze if the extract air is humid. A protective function then automatically reduces the speed of the supply air fan. Under such conditions, variations in the fan speed are therefore normal.

Filters

The ventilation unit must not be operated without filters. Use only filters recommended by Swegon in the ventilation unit.

Commissioning

The settings of the airflows for the Home, Away and Boost modes should be entered according to the project planning instructions so that the ventilation unit will operate correctly. The ventilation should not be commissioned until all work that produces large quantities of grinding dust or other impurities has been completed.

2.1 Control from the Premium cooker hood

The ventilation unit fan speeds and other settings should be entered via the Premium control panel. When you have entered these settings, the functions below will be available from the cooker hood control panel.

- The cooker hood damper: When preparing food or carrying out a similar activity, a 30, 60 or 120 minute damper-open period can be selected. One single press of the button changes the time one step. The fourth press of the button cancels the setting and closes the damper.
- The cooker hood lighting: On/Off.
- Ventilation unit fan speed: The fans inside the unit can be controlled to operate at three speeds: Home/Away/Boost. One single press of the button will increase the fan speed one step. The period for the boost speed is preset to 60 minutes, after which the ventilation unit will return to normal airflow.
- Alarms with flashing indicating lamps. See also the Alarms section in the instructions for use.



1. Indication for control of the cooker hood shut-off damper, 30/60/120 min.
2. Lighting
3. Ventilation unit fan speed: Away, Home, Boost

2.2 Control from the Premium control panel

When the power is switched on, the ventilation unit starts up in the Home operating mode. The start time is approx. 1 minute, and after that the control panel can be used. Likewise after a power failure, the ventilation unit will start up in the Home operating mode if the memory has been cleared during the power failure.

The functions of the push buttons are described in the image to the right.

2.2.1 Fireplace switch function

The fireplace function is not displayed as standard, but must be activated from the service menu. The fireplace switch function decreases the extract air fan speed and increases the supply air fan speed for approx. 10 minutes. This produces excess pressure in the home and in this way creates an updraught in the chimney.

2.2.2 Selection of fan speed

The fans inside the unit can be controlled to operate at three speeds: Home/Away/Boost. Select the required fan speed from the control panel.

Timer-controlled airflow boost is available.

The operating mode can be manually changed, even when the fan speed is controlled by the weekly timer.

2.2.3 Menu/Installation and service

You can enter settings that affect the operation and functions of the ventilation unit from the Installation and service menu and submenu. These settings are normally entered while installing the system and they are described in the installation instructions, Sections: "Main menu" and "Installation and service".

2.2.4 Signal lamp

The signal lamp on the control panel indicates the functions and alarms of the ventilation unit with various colours. See the instructions for use in the Alarms Section.

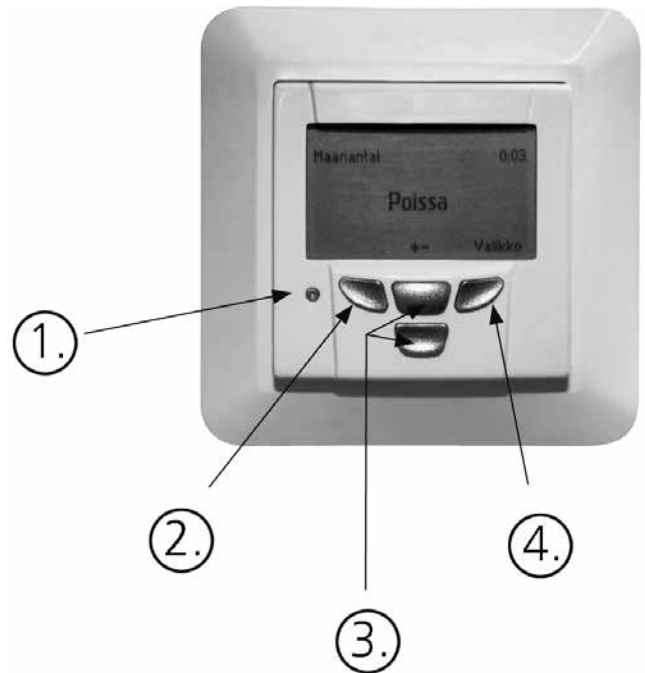

1. Signal lamp
2. Fireplace function / Return to previous menu level / Veer to the left.
3. Select fan speed / Scroll upward/downward / Enter values
4. Menu / Veer to the right / Set

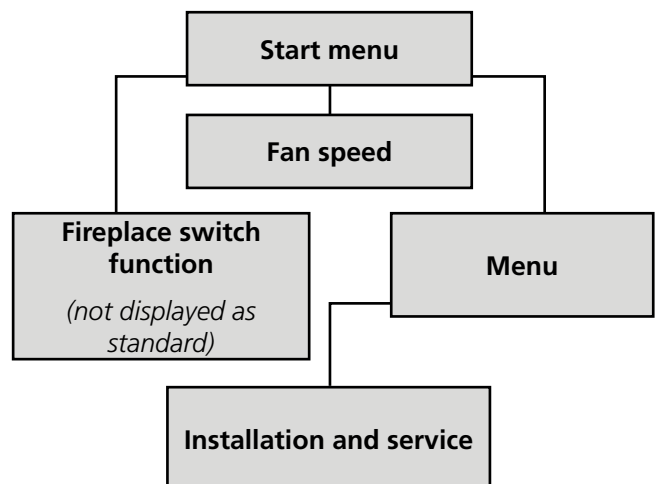

2.3 Filter change

! The owner of the building can change filters himself. Other servicing must be carried out by qualified service personnel.

2.3.1 Extract and outdoor air filter

The filter should be vacuum cleaned or brushed clean every six months and should be replaced at least once per year. It may be necessary to clean or replace the filter more often in homes where there is considerable dust.

2.3.2 Supply air filter

The filter should be vacuum cleaned or brushed clean every six months and should be replaced at least once per year. If the air is highly polluted, e.g. due to heavy traffic, the filter should be replaced more often.

! The ventilation unit must not be operated without filters! Use only filters recommended by Swegon are permissible for use in the ventilation unit. See the correct type of filter in the "Component list" Section.

2.4 Service reminder

The ventilation unit's control system is normally preset for displaying a service reminder every six months. You can change the time setting. When servicing is completed, acknowledge the service reminder from the Premium control panel. See Sections: "Installation and service". Otherwise the reminder will appear again.

2.5. Alarm

Alarms from a Premium control panel

- The indicating lamp is flashing red: The automated protection system has stopped the fans due to a malfunction. The cause of the current alarm is shown in the display. Perform service on the ventilation unit.
- The indicating lamp is lit with a steady red glow: Alarm or a service reminder. The cause of the current alarm is shown in the display. Perform service on the ventilation unit. (The reminder prompting you to change the filters does not mean you have to contact a servicing company.)
- The indicating lamp indicates certain unit functions with other colours. See the Section: "Premium control panel".

The locations of the filters in a ventilation unit in the right-hand version. The locations of the filters are mirror-inverted in a ventilation unit in the left-hand version.

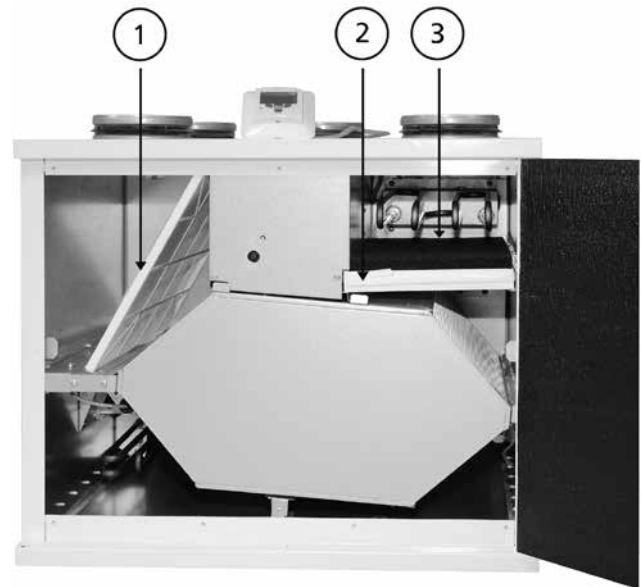

1. Extract air filter
2. Supply air filter
3. Outdoor air filter

3. General Description

3.1 Basic functions

How to activate and set the functions is described in the Section: "Operation".

3.1.1 Fans

The fans can be controlled to different operation modes from a control panel or a Premium cooker hood.

- Away = a low airflow, which can be used when no one is present in the home.
- Home = normal airflow.
- Boost = a high airflow, used in connection with cooking, taking a sauna bath, drying laundry and similar activities.

The Away/Home operating modes can be controlled with the ventilation unit's built-in weekly timer; however the operating mode can always be changed from the Premium control panel or a Premium cooker hood.

The airflow boost time is selected manually to 30, 60 or 120 minutes from a Premium control panel. When the

unit is controlled from a Premium cooker hood, the fan's boost time is 60 minutes and the time that the damper is open can be selected to 30, 60 or 120 minutes.

3.1.2 Temperature

The user sets a supply air temperature of his or her choice, normally 13–20 °C. This setting is a so-called setpoint, which the ventilation unit makes an effort to reach, if conditions allow this.

N.B.! In the Econo models, the setpoint can be set with a thermostat inside the ventilation unit.

A heat exchanger collects heat energy from the extract air and transfers it to the supply air. When the heat exchanger's heating power is not sufficient, the electrically heated air heater is activated and heats the air to reach the supply air setpoint.

The air heater can be switched off from the control panel if heating is not required.

N.B.! If the bypass shutter for summer ventilation is open, the electric air heater will not operate.

In the Econo models, you can set the desired supply air temperature with a thermostat inside the ventilation unit. You can turn the thermostat dial to the minimum setting if heating is not required.

3.1.3 Protective functions

The electric air heater has two protective functions.

- The excess temperature (thermal overload) protection switches off the heater, if the temperature exceeds 50 °C. The protection automatically resets itself when the air heater has cooled down.
- The excess temperature protection switches off the heater, if the temperature exceeds 90 °C. The protection must be manually reset by pressing a push button on the heater.

The heat exchanger is equipped with a freeze protection. If there is risk of the heat exchanger freezing under cold weather conditions, the air heater is activated and the controller reduces the speed of the supply air fan. This protective function automatically resets itself when the temperature increases.

The fans have a thermal overload cutout, which stops them if the temperature rises too high. The controller also stops the fans if a serious malfunction occurs in the ventilation unit. When the temperature drops or the malfunction has been remedied, the protection automatically resets itself in both cases.

On the Econo models, there is a temperature sensor that protects the waterborne air heater from freezing.

- If the air heater's temperature has dropped to a risky level, the red signal lamp on the control panel will flash, but the ventilation unit will operate normally.
- If the air heater's temperature drops further, the controller will stop the ventilation unit to prevent the air heater from freezing. The freeze protection alarm can be acknowledged from the Installation and service menu: Alarms.

3.2 Optional equipment – automated control equipment

How to activate and set the functions is described in the Section: "Operation". The connection of optional items of equipment is described in the wiring diagram in the Section: "Technical data".

The optional items of equipment can be used for achieving the type of control required in the following way:

- **Boost switch with timer.** The boosted operation mode can be switched in from a control panel or a Premium cooker hood. A separate boost timer (push button) can e.g. be installed in a sauna, bath room, laundry room, etc.
- **Humidity sensor.** When the preset limit value is exceeded, e.g. 60 % relative humidity (RH), the controller switches the fans to operate in the boost mode. The humidity sensor can be located in a bathroom, a laundry room, etc. The sensor voltage is 24 V DC.
- **Separate fireplace switch.** The function can be switched in from a control panel or a Premium cooker hood. A separate fireplace switch (push button) can be installed e.g. next to an open fireplace.
- **Occupant detection sensor.** The sensor detects movement in the home and increases the fan speed to the Boost operating mode.
- **Carbon dioxide sensor.** It is suitable for use in cases where the number of occupants varies. The sensor increases the fan speed to the Boost operating mode when a preset limit value is exceeded, e.g. 900 ppm.
- **Negative pressure compensation.** Negative pressure arises in the home when a separate cooker hood or central vacuum cleaner is used, since the extract airflow becomes substantially higher than the supply airflow. A separate sensor (e.g. one that senses the difference in pressure) can transmit a signal to the controller to increase the supply air flow from the ventilation unit to restore balance.
- **Supervision (DDC).** By using the Modbus gateway, some functions can be controlled from an automated building management system. See the connection schedule for optional items of equipment in the Section: "Technical data".
- **Home/Away switch.** For example, systems controlled from a cooker hood, generally have a separate Home/Away switch (optional extra) by the front door. The switch starts the Away function in the ventilation unit. The switch can be a standard switch of optional type.
- **Duct equipment.** External operating voltage (24 V DC) can be supplied from the circuit card to motor-driven damper motors. If you for example switch off the voltage supplied to the ventilation unit, the spring loaded damper motors will close the shut-off dampers in the fresh air and exhaust air ducts. When the voltage is switched on, the shut-off dampers will open again. A maximum of two damper motors can be connected.

4. Installation

4.1 General

You can install the ventilation unit in a machinery room, a laundry room, a storeroom, etc. The temperature in the installation space must be constantly more than +10 °C.

The ventilation unit conforms to enclosure class IP 44 when the inspection door is closed.

If needed, connect the extract air from the Premium cooker hood via a duct to the extra duct connection spigot on the top side of the ventilation unit. On delivery, this spigot is blanked off.

The ventilation unit's inspection door and heat exchanger can be removed to make it easier to lift the unit. The fans can also be removed if necessary. See the Section: "Servicing".

The ventilation unit can be mounted either on the wall with a wall mounting bracket included in the supply or on the ceiling with a mounting frame which is available as an optional extra. The unit should be mounted as near as possible to the wall or ceiling. The space between the ventilation unit and the wall/ceiling must be insulated to prevent the sound from the unit from being transmitted through the wall and out into the room.

4.2 Ventilation unit installation site

⚠ The ventilation unit should not be secured to a wall that borders to a living room or a bedroom. Make sure that the electric and control cables are accessible. See also the Section: "Electric and control cables".

Check whether the ventilation unit has been supplied in the right-hand or left-hand version to make certain that you are connecting the air ducts to the correct duct connection spigots on the unit. See also the dimensional drawings in the Section: "Technical data".

4.2.1 Wall mounting

Secure the ventilation unit to the wall with the wall mounting bracket.

If the wall is composed of vertical studs and building boards. The wall must be reinforced with horizontal studs that can manage the weight of the unit.

Swegon also recommends that the wall be insulated with mineral wool or similar insulation for preventing sound from propagating to other rooms.

Secure the mounting bracket horizontally to the wall with screws, using a suitable means of anchoring that can support the weight of the ventilation unit.

The insulation supplied should be fastened to the rear side of the ventilation unit before the unit is lifted into place. Lift up the ventilation unit onto the wall bracket so that the catches on the bracket engage in the corresponding notches at the top on the backside of the unit.



Firm insulation that comes with the wall mounting bracket behind the ventilation unit.



Wall mounting bracket

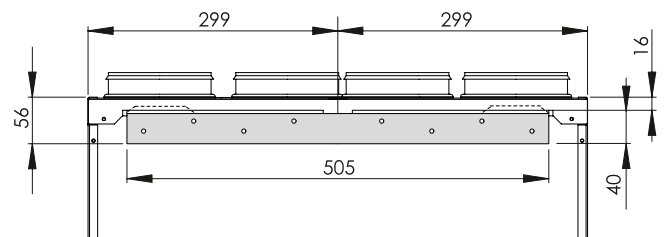

Wall mounting bracket's dimensions

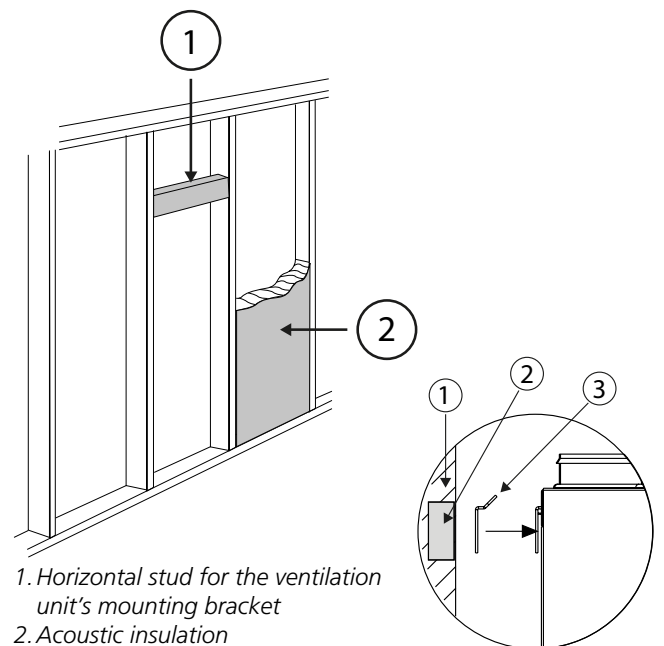

*1. Horizontal stud for the ventilation unit's mounting bracket
2. Acoustic insulation*

*1. Insulated wall
2. horizontal stud
3. Wall mounting bracket*

4.2.2 To install the ceiling mounting frame

Fasten the ceiling mounting frame **available as an optional extra** with four M8 threaded rods in the ceiling anchor sleeves so that at least three of the threaded rods are aligned with the corners of the ceiling mounting frame. To avoid a possible collision with the ducts, one of the threaded rods can be located in the hole next to the corner. Screw in the M8 nuts onto the threaded rods to such a height that the ceiling mounting frame will be horizontal when the top of the frame goes against the nuts. Fit the mounting frame through the selected holes against the nuts on the threaded rods and lock the frame into position with nuts from below. The ends of the threaded rods are permitted to protrude no more than 3 cm from the ceiling mounting frame plate, otherwise they will extend into the unit's upper casing section.

 **If you improperly tighten the ceiling mounting frame, this could turn the frame and the ventilation unit will not have room inside the frame.**

4.2.3 Installation in ceiling mounting frame

Fasten the mounting hooks in the mounting opening on the ventilation unit's top side by means of tension rivets. The hooks should be turned so that the sharp point will point towards the rear side of the ventilation unit.

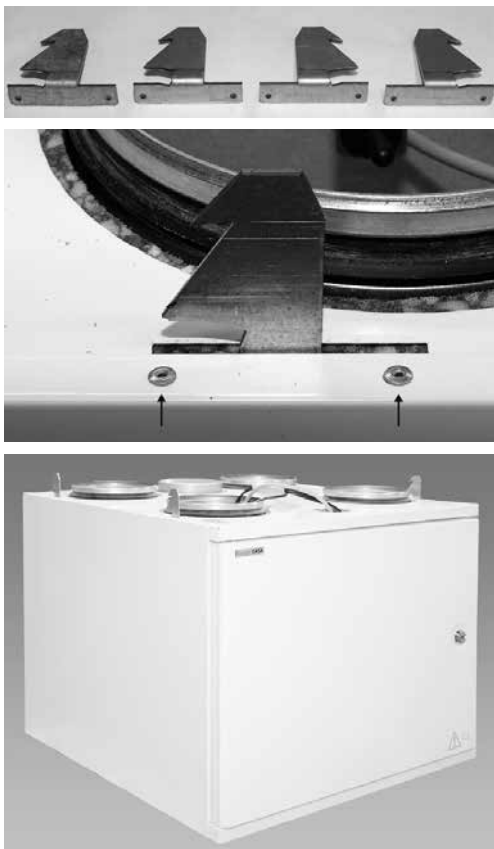

Back off the two screws at the front of the ceiling mounting frame so much that the screw heads stick out approx. 2 cm. Before you lift the ventilation unit into position, run the power supply and data cables, and the water tube (on the Econo model), through the ceiling mounting frame. Lift

the ventilation unit into the ceiling mounting frame so that all four locking hooks fit correctly in the openings. There are two catches on each locking hook. The purpose of the upper one is to secure the ventilation unit to facilitate connection to the ducts and the wiring of the electric cables.



When the unit is in the correct position in relation to the duct and the electric cables and water tubes, if fitted, have been run into the ventilation unit, lift up the unit to rest on the lower catches. When the catches are locked, the screws of the upper section fan out. Finish by ensuring that the ventilation unit is properly secured at its location by slightly tightening the screws in the upper casing section.



Secure the ventilation unit in position by tightening the screws in its front panel.

4.3 Condensate discharge

Connect the condensate discharge hose to the ventilation unit's condensate discharge connection (3/8" male threads). Convey the condensate to a floor drain, the water trap of a sink or the equivalent by means of a hose or a pipe having an inner diameter of at least 12 mm. The water must not be led away directly to the sewer.

Vertically mount the water trap on the hose supplied with the unit and fill it with water. The hose must not have a second water trap or be run horizontally. The water trap should have a damming height of at least 100 mm.

 **Remove the installation instructions and the condensate hose from the ventilation unit before commissioning it.**

4.4 To connect the cooker hood

The cooker hood is usually connected to the ordinary extract air duct. However the cooker hood can be connected to the ventilation unit's separate extract air connection, in order to meet national regulations or for achieving a more effective than normal extract airflow.

If you connect the cooker hood to a separate extract air duct it is important to keep in mind that the airflow will then bypass the heat exchanger and this could cause an activation of the freeze protective function earlier than normal.

 **You must absolutely not direct the base airflow from the kitchen via the cooker hood, since it would then pass by the heat exchanger and the ventilation unit would not operate as intended.**

If separate extract air is arranged, the duct connections of the cooker hood can be connected via a duct to the connection on the top side of the ventilation unit. The duct between the cooker hood and the ventilation unit must be mounted in such a way that makes it possible to clean it.

On delivery, the connection for separate extract air is blanked off.

4.5 Electric and control cables

A 1.5 m long cable with earthed plug-in contact is fitted to the ventilation unit for measuring the voltage. The cable extends from the top of the unit. The mains plug serves as the ventilation unit's main switch and it should be connected to an electric socket at an easily accessible spot. For power required, see the Section: "Technical data".

Connect the ventilation unit to a Premium control panel via a modular cable. Included in the supply of the control panel is a 20 m. long modular cable, which can be used for cable pulling to locate the panel at the place of your choice.

When installing the unit, make sure that you provide

adequate access to the connector of each cable (loose ones as well), e.g. for servicing and adjusting the unit, if and when the need arises.

In multi-storey buildings, a control panel can be used as a so-called hand-held micro terminal in conjunction with service and installation work.

The diameter of the modular cable wiring tube should be 20 mm.

The connection of possible optional items of equipment is described in the wiring diagram in the Section: "Technical data". The cables for the optional items of equipment are not included in the supply.

 **The electric and control cables are located on the top side of the ventilation unit. Make sure that the electric cable can be connected to a wall outlet without obstruction.**

 **If the modular cable is lengthened within some building element (e.g. a wall), the cable should be lengthened in a \varnothing 20 mm conduit, bearing in mind a possible later change of cabling.**

 **If any further electrical wiring is required, only a qualified electrician shall be allowed to carry out this work.**

4.6 Ducts

Install the air ducts, sound attenuators, supply air diffusers and air intake grilles as shown in the ventilation drawings. To prevent the propagation of sound, do not install the ducts directly against structural building elements.

Insulate the air ducts in order to reduce loss of heat or cooling energy and to prevent water from condensing on surfaces. In addition, it is advisable to insulate the ducts to prevent the spread of fire.

In general, ventilation ducts are insulated in the following manner:

- Outdoor air ducts are insulated in warm spaces and in attics that are used.
- Exhaust air ducts should always be insulated in accordance with national regulations. See separate project planning instructions (for example Fire resistance requirements).
- Insulate supply air ducts in cold spaces.
- Insulate extract air ducts in cold spaces.
- If the air inside the duct is colder than in the surroundings, the insulation should be protected by a moisture barrier.

4.7 To seal around duct penetration collars

We recommend the use of a mounting frame designed specifically for your ventilation unit (optional extra) for sealing the vapour barrier in the attic tie beams.

It is important to the vapour barrier maintains its tight fit at the duct penetration collars. A duct penetration piece (optional extra) facilitates this. This item is available in sets of 5 pieces, for diameters: 100, 125 and 160 mm. Fasten into the vapour barrier with tape.

Cut up the openings with approx. 10 mm smaller diameter than that of the ducts. Secure the mounting frame in the ceiling with screws through the holes on the sides. The plastic film of the moisture barrier should either be stretched and fastened between the mounting frame and the structural element of the building, or be taped tightly against the mounting frame.

! It is absolutely forbidden to use the ventilation system during the building construction period or if dust-raising work is in progress. The ducts should be covered with covers to prevent impurities from entering them. It is essential that the ventilation ducts are clean in order for the ventilation unit to operate as it should.

! The thickness of the insulation and the nature of the surface layer of the ventilation ducts vary depending on insulation material, climate zone and national standards in force. For this reason, Swegon does not offer any recommendations. Most manufacturers of insulation material offer calculation programs for the calculation of sufficient and correct insulation. In renovation projects, it is advisable to examine the existing ducts to determine whether they are sufficiently and correctly insulated. Insulating in the right way is necessary for the ventilation unit to operate correctly.

4.8 Installation of the Econo model

The pipe connections of the Econo model should be arranged inside the ventilation unit. The connection work will be facilitated if you temporarily remove the heat exchanger and filter from the unit. Connect the supply pipe to the thermostat (3/8" female threads) and the return pipe to the ball valve's 15 mm dia. connection.

! The Econo model requires a continuous circulation of hot water during the heating season.



To dismantle the front plate on a Premium control panel.

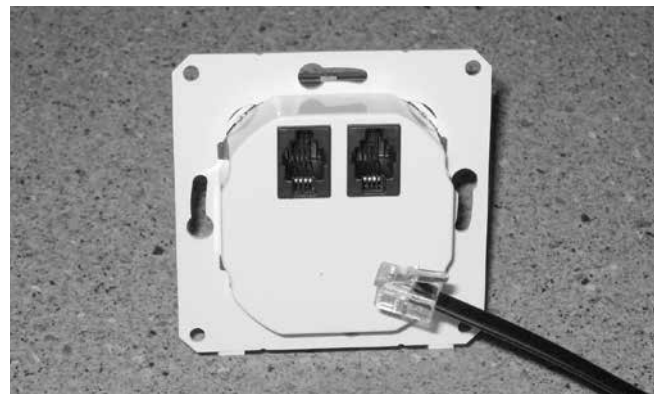

To connect the modular cable. The extra plug terminal is used for an extra control cable.



To secure the panel cover on the Premium control panel. First place the upper edge of the cover in place and then press the cover to secure it.

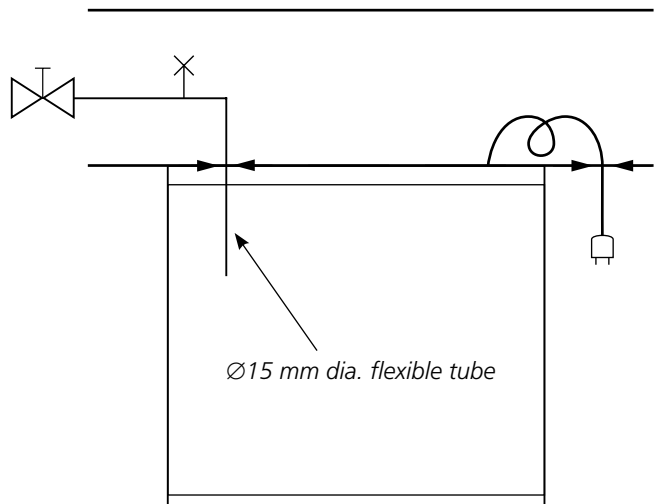

5. Application

5.1 To set the airflows

The home should have continuous air change to ensure a pleasant indoor climate and avoid damage to building elements due to humidity. The ventilation unit should be stopped only while service work is in progress.

The airflows should be set according to the ventilation plan and applicable regulations. For estimated values, use the sizing curves in the Section "Technical data". A qualified person should set the ventilation unit's and the ventilation equipment's airflows using appropriate measurement equipment.

A low airflow when the home is unoccupied means economical operation. This saves on fan energy and the home heating system does not have to heat as much air during the cold season. An assessment of whether a low airflow is sufficient for removing emissions, moisture, etc. from the air should be made.

 **Check that the ventilation unit, filters and ducts are clean and that there are no loose objects in them before commissioning the ventilation system.**

5.2 Bypass past the heat exchanger

The bypass of air past the heat exchanger is a built-in function in the ventilation unit. This function is used to prevent heat recovery on hot summer days. The bypass is activated by opening the cover in the extract air chamber's bypass duct by pulling the cover outward towards the service cover. When the next heating season begins, you simply close the bypass cover. When the cover is open, the power supply to the electric air heater is switched off.



Bypass past the heat exchanger: The cover closed in the winter; open in the summer.

5.3 Premium cooker hood

The ventilation unit fan speeds and other settings should be entered via the Premium control panel. When you have entered these settings, the functions below will be available from the cooker hood control panel.

- The ventilation unit fan speed. The fans inside the unit can be controlled to operate at three speeds: Home/Away/Boost. One single press of the button will increase the fan speed one step. The period for the boost speed is preset to 60 minutes, after which the ventilation unit will return to normal airflow.
- The cooker hood damper. When preparing food or carrying out a similar activity, a 30, 60 or 120 minute

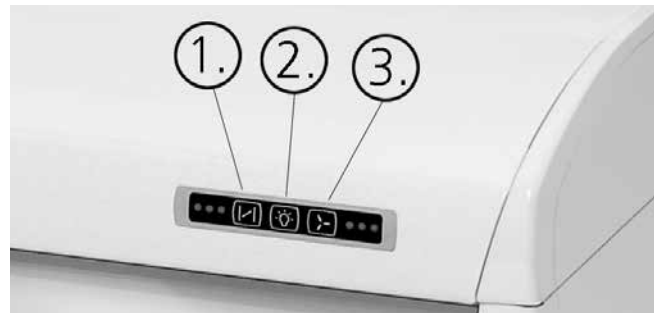

1. Indication for control of the cooker hood shut-off damper, 30/60/120 min.

2. Lighting

3. Ventilation unit fan speed: Away, Home, Boost

damper-open period can be selected. One single press of the button changes the time one step.

- The cooker hood lighting. On/Off.

5.4 Premium control panel

When the power is switched on, the ventilation unit starts up in the Home operating mode. The start time is approx. 1 minute, and after that the control panel can be used. Likewise after a power failure, the ventilation unit will start up in the Home operating mode if the memory has been cleared during the power failure.

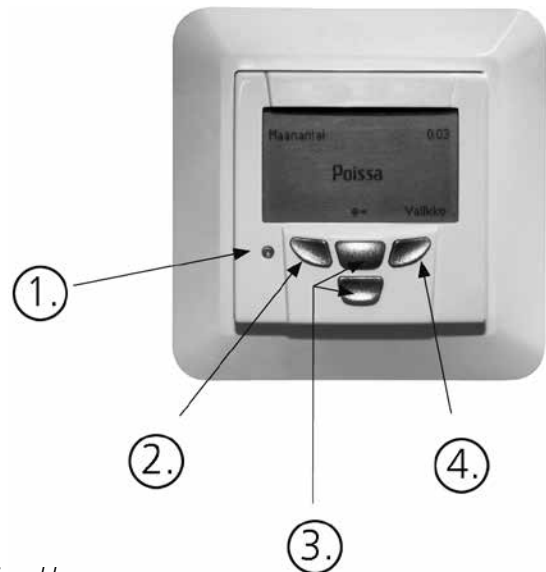

1. Signal lamp

2. Fireplace function / Return to previous menu level / Veer to the left.

3. Select fan speed / Scroll upward/downward / Enter values

4. Menu / Veer to the right / Set

The indicating lamp on the control panel shows the various functions of the ventilation unit in different colours.

- Steady green glow: The ventilation unit is operating normally.
- Flashing green glow: The freeze protection has been activated.
- Orange flashing glow: The electric air heater has been activated.
- Flashing red glow: The automated protection system has stopped the fans due to a malfunction.
- Steady red glow: Alarm or a service reminder.

5.5 Start menu

 **When the freeze protection function is activated, you cannot change the ventilation unit fan speeds from the control panel.**

5.5.1 Fireplace switch function

The problem of too little draft in an open fireplace is most common in the autumn, when the temperature difference between indoor and outdoor air is slight and the chimney is cold.

The fireplace switch function decreases the extract air fan speed and increases the supply air fan speed for approx. 10 minutes. This produces excess pressure in the home and in this way creates an updraught in the chimney.

Unnecessary or long-term use of the fireplace switch function in the wintertime easily activates the frost protection function which creates negative pressure in the house and smoke can be drawn into the house via the chimney.

The fireplace function can be switched off by pressing in the button once again.

The ventilation unit is no source for necessary replacement air while a fire is burning in the fireplace.

The function is shown in the display only if the value is "On" in the Functions Menu. The standard value is "Off".

5.5.2 Fan speed

Select the appropriate fan speed. Timer-controlled airflow boost is available. The operating mode can be manually changed, even when the fan speed is controlled by the weekly timer.

5.6 Main menu

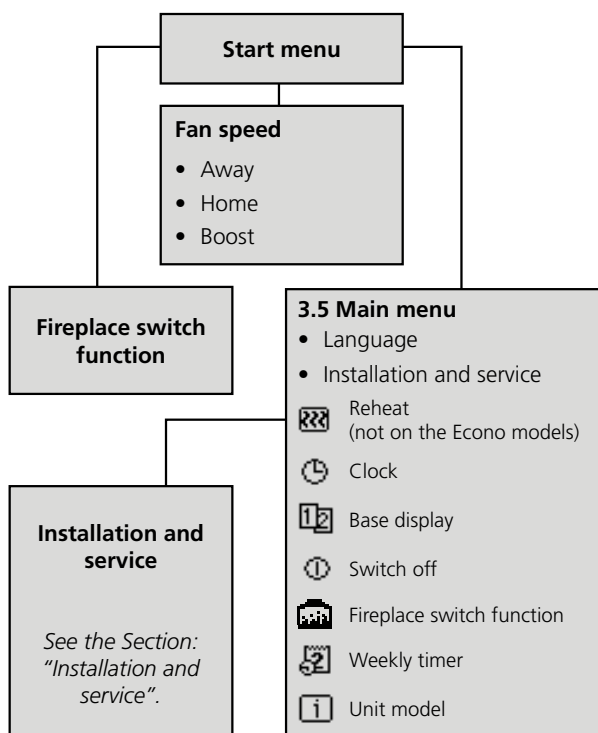

You can enter settings that affect the operation and functions of the ventilation unit from the menu.

A number of functions are available in the Main menu as well as in the Installation and Service submenu.

From the Montage and service menu, you select whether the function should be used and certain settings. The function must be activated from the main menu.

5.6.1 Language

Select the appropriate language.

5.6.2 Installation and service

See the Section: "Installation and service".

5.6.3 Reheat (not on the Econo models)

You can choose whether or not you want to use reheat.

5.6.4 Clock

Select date and time of day.

5.6.5 Base display

Basic display 1 is selected when the fan speeds in the Away/Home/Boost steps are to be changed.

Basic display 2 is selected when the fan speeds are to be changed in five different steps.

5.6.6 Shutting down

The ventilation unit fans, the heat exchanger and an air heater, if fitted, are stopped. The circuit card is however still energised and the settings are preserved in the memory.

5.6.7 Fireplace function

Select ON as the value for this function, if you wish to use the function from the control panel display, otherwise select Off.

5.6.8 One-week timer

Four different programs can be selected on the weekly timer, with the Away/Home/Boost fan speeds. Manual operation from the control panel bypasses (overrides) the weekly timer functions.

5.6.9 Ventilation unit model

Shows the model of the ventilation unit.

5.7 Installation and service

The menu is can be opened by entering code 1234.

Installation and service

- Alarm/Service reminder
- Time switch clock (timer)
- Temperature
- Measurements
- Control functions
- Fan speeds
- Switch off
- Factory settings
- Controller
- Functions
- Air heater

5.7.1 Alarm/Service reminder

Sensor fault. The "In operation" alternative should be selected as the value for the temperature sensors. If any sensor malfunctions, get in touch with service personnel. Sensor errors can be acknowledged from this menu.

The service reminder appears on the screen at six-month intervals. After service, acknowledge the reminder from the Service reminder point "Acknowledge". "Service OK" will then appear on the display screen and a new period of six months will begin. The time period leading up to the next service reminder can be changed from the "Functions" menu.

Alarms for functional malfunctions are shown in the display. "Freeze risk". (Econo models)

The water-heated air heater's freeze risk warning can be acknowledged from the "Freeze risk" point. One prerequisite for acknowledgement is that the temperature by sensor T6 exceeds 16 °C.

5.7.2 Clock

"On" or "Off". The clock is shown in the start menu.

5.7.3 Temperature

"On" or "Off".

The supply air temperature control function is shown in the start menu. Select ON in order to use the function for setting the supply air temperature, otherwise select Off. (The models with electric reheating.)

5.7.4 Measurements

Depending on whatever accessories are connected, the following can be measured: the carbon dioxide content (CO₂), temperature, pressure differential, the speed of the fans and relative humidity (RH).

5.7.5 Control functions

Carbon dioxide content (CO₂), supervision (DDC) or timer can be selected as a control means.

5.7.6 Fan speeds

One of five fan modes (1-5) can be selected for each operating mode (Away, Home, Boost etc.). The factory setting is Away 1, Home 3, Boost 5.

The various fan mode speeds (expressed as a percentage: 10 – 100) can be selected (separate for supply air and extract air).

5.7.7 Shutting down

The ventilation unit fans, the heat exchanger and an air heater, if fitted, are stopped. The circuit card is however still energised and the settings are preserved in the memory.

5.7.8 Factory settings

All settings except the fan speeds are reset to factory values.

5.7.9 Controller

It is possible to select settings for duct equipment, the valve actuators or circulation air regulation. The function of the menu depends on the model.

5.7.10 Functions

- Select ON as the value for Negative pressure compensation, e.g. if the cooker hood has a differential

pressure monitor in the extract air duct of the cooker hood for this function, otherwise select OFF.

- Select ON as the value for Service reminder, if the function is to be used, otherwise select Off. The time interval (6 months) can be changed.
- Select On as the value for Heating, if an air heater is installed, otherwise select Off. 50 °C is the limit value for high temperature. This temperature limit can be changed. Control supply air fan is selected as the control means. The control means can be changed to Room controlled, but this alternative cannot be used on this model.
- Select On as the value for Filter guard, if a filter guard is installed, otherwise select Off. Filter monitor is available only on certain models, **not on the W100**.
- Select On as the Fireplace switch function setting, if a fireplace switch has been installed, otherwise select Off. The fireplace switch function decreases the extract air fan speed and increases the supply air fan speed. The freeze protection works in the reverse manner: It stops the supply air fan and only allows the extract air fan to run.
- Select On as the value for Boost, if a boost timer or a presence detector is installed, otherwise select Off.

5.7.11 Electric air heater

Air heater for preheat

Choose whether you want to use preheat or whether it should be taken out of operation completely. The factory setting is "In operation". When preheat is "In operation", you can enter the following:

- The temperature of the air supplied to the ventilation unit is limited to the desired limit value (factory setting: -20 °C).
- When the freeze protection is activated, the air heater is always in operation.
- Excess temperature – limit of the excess temperature protection in the preheat chamber (factory setting: 50 °C).

The air heater for preheat can also be put in operation as a separate function while negative the pressure compensation and/or fireplace function is operating. The function can be limited based on the outdoor air temperature, so that the air heater will not start unnecessarily. The factory setting for outdoor air temperature is 0 °C.

Air heater for reheat (does not apply to the Econo models)

The reheat factory setting is "In operation". The air heater for reheat can be taken out of operation from the menu.

When reheat is "In operation", you can enter the following:

- Outdoor air temperature – Choose a temperature limit, which indicates at what temperature the reheater should start (factory setting: 15 °C).
- Excess temperature – limit of the excess temperature protection in the preheat chamber (factory setting: 50 °C).



- * = 8 °C
- 1 = 11 °C
- 2 = 14 °C
- 3 = 17 °C
- 4 = 20 °C
- (5 = 23 °C)
- (6 = 26 °C)

Econo model's thermostat for setting the temperature

6. Servicing

6.1 Service reminder

The ventilation unit's control system is normally preset for displaying a service reminder via the Premium control panel every six months. If required, this function can be altered in the Installation and Service menu. From same menu you set to zero the service reminder after performed service.

6.2 To open the ventilation unit

Isolate the power supply voltage to the ventilation unit (pull out the mains plug from the wall socket). Wait a few minutes before you open the inspection door on the ventilation unit, so that the fan will have time to stop and the air heaters can cool down.

6.3 Filter change

- To open the inspection door.
- Wait a few minutes, so that the fans have time to stop and the air heaters, if fitted, have time to cool down.
- Change the filters.
- Close the inspection door.

The filters should be vacuum cleaned every six months and should be replaced at least once per year.

 **The ventilation unit must not be operated without filters! Use only filters recommended by Swegon in the ventilation unit. Find the correct filter in the Section: "Technical data".**

The locations of the filters in a ventilation unit in the right-hand version.

The locations of the filters are mirror-inverted in a ventilation unit in the left-hand version.

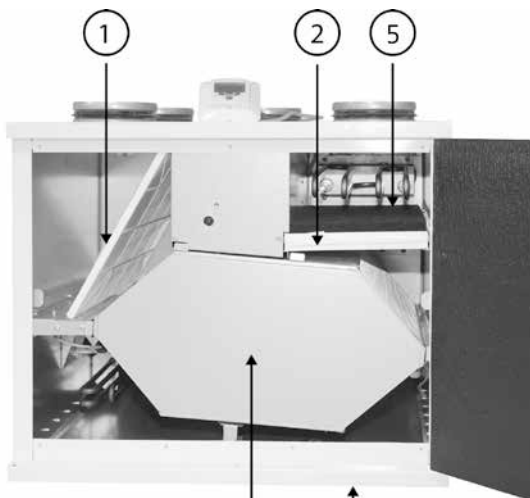

1. Extract air filter, G3
2. Supply air filter F7
3. Plate heat exchangers
4. Condensate connection
5. Outdoor air filter, PPI-20

6.4 Other servicing

At least once per year.

Remove the plate heat exchanger for inspection. Ensure that the heat exchanger passages are not clogged. Clean with a soft brush, vacuum cleaner or under running water, if needed. If you find it necessary to use detergent, choose one that does not corrode aluminium.

The passages of the heat exchanger should be dry before you refit it.

The ventilation unit fans can be removed for cleaning or replacement. The fan blades can be cleaned by carefully brushing their surfaces. Perform service on one fan at a time.

First remove the heat exchanger and the supply air filter from the ventilation unit before you unfasten the fans. Then disconnect the plug-in contacts of the fans (note the locking mechanism on the side of the contact) and unscrew the locking devices of the fans from the partition wall. Undo the locking devices and tilt the lower part of the fan toward the rear wall until the fan disconnects from the bracket behind. Turn the fan sideways and work it out of the ventilation unit. Be careful not to damage the insulation on the electric cables.

Reinstall the fans by inserting them and turning them near their final positions. Tilt the lower part of the fans toward the rear wall and move the discharge section of the fan along the side wall toward the rear locking device. Straighten the fan and push the locking bolt into position through the cover in the partition wall and fasten it at the intermediate wall with two screws. Connect the plug-in contacts and install the heat exchanger and supply air filter into position.

- Clean the inner surfaces of the ventilation unit, if needed.
- Check that the condensate discharge outlet is not clogged and check its outflow by pouring water on the bottom of the ventilation unit.



The fan's locking device

7. Alarms and troubleshooting

7.1 Alarms

7.1.1 Alarms from a Premium control panel

- The indicating lamp is flashing red: The automated protection system has stopped the fans due to a malfunction. The alarm text is shown in the display. Remedy the malfunction.
- The indicating lamp is lit with a steady red glow: Alarm or a service reminder. The alarm text is shown in the display. Remedy the malfunction or perform service on the ventilation unit.
- The indicating lamp indicates certain unit functions with other colours. See the Section: "Premium control panel".

7.2 Troubleshooting:

Possible malfunctions are indicated by alarm texts on the Premium control panel according to the Section: "Alarms". Inspect the components related to the malfunction and remedy the malfunction.

7.2.1 The supply air is not sufficiently heated

Low temperature setting for the supply air

Investigate and, if necessary, increase the temperature from the menu, or on the Econo model with the thermostat inside the ventilation unit. At the same time check that bypass for summertime operation is not open.

The electric air heater is faulty

The air heater has one excess temperature and one overheating protection functions. An alarm according to the Section "Alarms" is initiated on the Premium control panel if either of these is activated.

The over temperature protection resets itself automatically when the temperature decreases. The overheating protection must be reset by pressing a push button on the air heater. If you hear a click when you press in the button, this indicates that the overheating protection has been reset.

Excessively high temperature may be due to too low an air flow through the air heater. The cause can be that a filter, outer wall grille or supply air device is clogged. Replace and clean, if needed.

Tip: The outer wall grille on most models has insect netting. If the net has small mesh, dust and insects can clog it. During certain conditions it is also liable to freeze. Remove the net or replace it with a net with larger mesh.

An excessively high temperature can also be due to the supply air fan having stopped or that the temperature sensor has been shaken loose from its position in the fan intake.

If the bypass damper for summertime operation is not completely closed, the air heater for reheat will not switch on.

Badly isolated ventilation ducts

If the unit emits warm air but the supply air discharged from the air diffuser feels cold, this may be due to poorly insulated ventilation duct.

The ventilation unit does not obey commands

If two overlapping commands are issued, the unit obeys the command with the highest priority, e.g. the freeze protection.

Priority 1: Commands from outer sensor or the ventilation unit's protective functions.

Priority 2: External supervision (DDC).

Priority 3: normal operation from the control panel or the cooker hood.



Freeze protection

During periods of cold weather, the heat exchanger is liable to freeze if the extract air is humid. A protective function then automatically reduces the speed of the supply air fan. Under such conditions, variations in the fan speed are therefore normal.

The LED on a Premium control panel flashes green when the freeze protection is activated.



1. Overheat protection
2. Air reheater, overheating protection

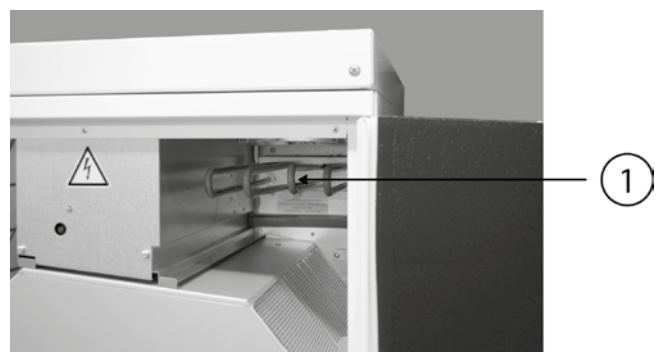

1. Air heater, preheating

8. List of components

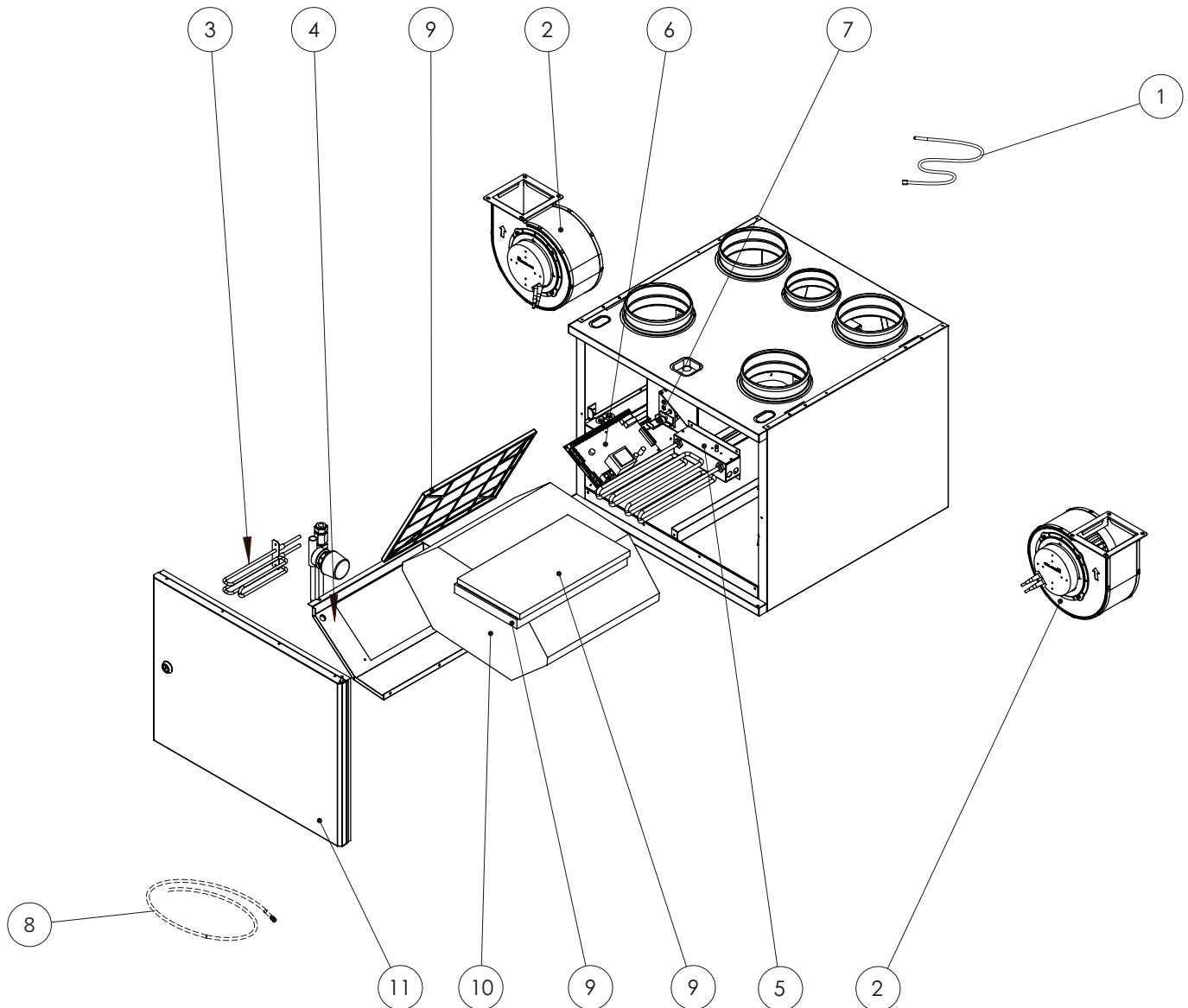

1. Temperature sensor

- 850 m, without contact (T1/T8): 603023
- 1,750 m, with contact (T2): 603016
- 1,100 m, with contact (T3): 603017
- 750 mm, without contact (T4, supply air sensor): 603018
- 750 m, with contact (T7): 603014
- 1,450 m, with contact (T6): 604919

2. Fans (ventilation unit in right-hand model)

- Supply air fan: PWEC175R
- Extract air fan: PEC119R

2. Fans (ventilation unit in left-hand model)

- Supply air fan: PWEC175L
- Extract air fan: PEC119L

3. Air reheater, reheat (models with electric air heater): 50269

4. Air heater, reheat (ventilation unit in left-hand model) (Econo models): 620221

4. Air heater, reheat (ventilation unit in right-hand model) (Econo models): 620222

5. Air heater, pre-heating

6. EC circuit card: 603012

7. Cover panel switch 60541

8. Condensate discharge hose 502103

9. Set of filters: PW080FS

10. Heat exchanger: 61031

11. Cover: DPW100RL

- Lock: 61950

9. Technical details

9.1 Fan Diagrams

Supply airflow

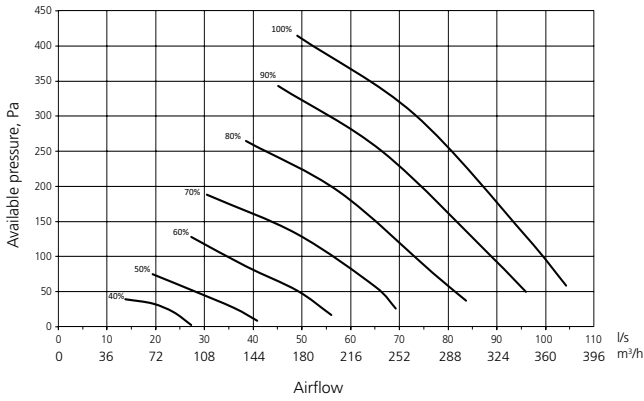

Supply airflow, Econo

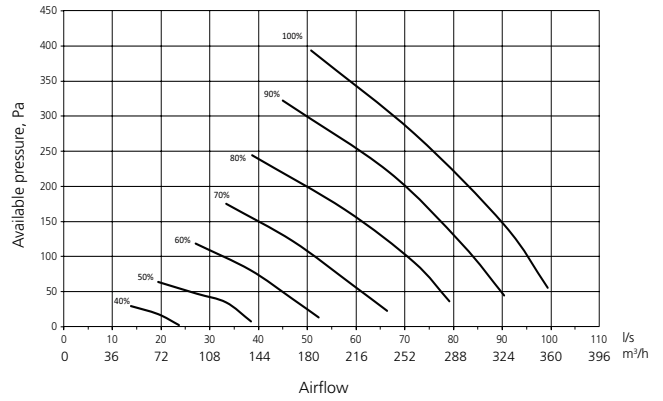

Extract airflow

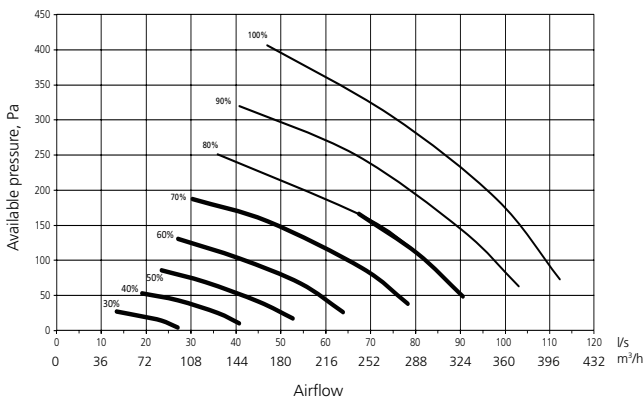

Extract airflow, Econo

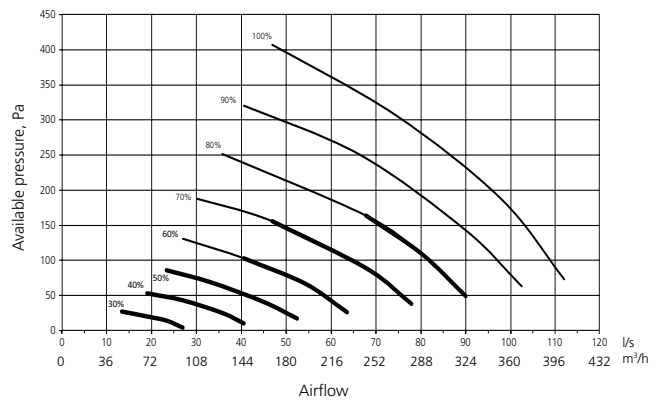

Thick line = SFP 2.0 or lower.

Power consumption

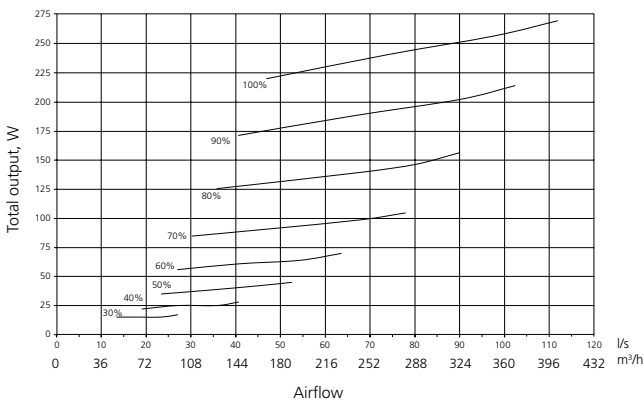

Power consumption, Econo

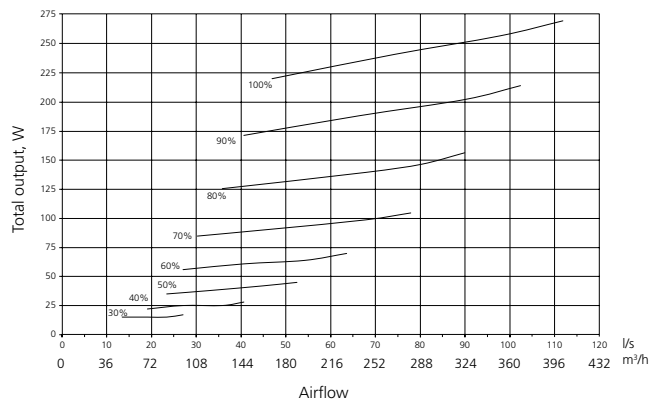

9.2 Acoustic data

Sound emitted to supply air duct

Fan setting %	Sound power level broken down into octave bands, $L_{w_{okt}}$ dB								Weighted sound power level L_{WA} dB(A)
	63 Hz	125 Hz	250 Hz	500 Hz	1,000 Hz	2,000 Hz	4,000 Hz	8,000 Hz	
40	61	57	53	45	44	38	31	20	50
50	67	62	62	52	48	43	37	26	56
60	70	66	61	54	52	45	42	32	58
70	73	69	65	58	55	51	48	39	62
80	75	71	68	61	57	54	50	42	65
90	78	73	71	64	59	56	53	45	67
100	79	75	75	67	60	58	55	47	70

Sound emitted to extract air duct

Fan setting %	Sound power level broken down into octave bands, $L_{w_{okt}}$ dB								Weighted sound power level L_{WA} dB(A)
	63 Hz	125 Hz	250 Hz	500 Hz	1,000 Hz	2,000 Hz	4,000 Hz	8,000 Hz	
40	49	49	41	35	28	20	-	-	38
50	51	57	47	39	33	25	13	-	44
60	57	60	52	42	36	29	20	-	49
70	56	64	57	43	34	32	24	11	52
80	64	65	60	48	40	35	28	16	55
90	-	68	62	50	42	37	30	19	56
100	65	69	65	51	43	38	32	21	60

Sound emitted to outdoor air duct

Fan setting %	Sound power level broken down into octave bands, $L_{w_{okt}}$ dB								Weighted sound power level L_{WA} dB(A)
	63 Hz	125 Hz	250 Hz	500 Hz	1,000 Hz	2,000 Hz	4,000 Hz	8,000 Hz	
40	-	-	37	30	27	17	-	-	32
50	-	57	46	36	36	21	-	-	44
60	59	62	51	42	36	30	17	-	49
70	59	64	55	45	40	32	22	-	51
80	66	67	58	49	41	37	28	15	54
90	-	68	61	52	44	39	32	20	57
100	59	71	64	55	47	42	36	24	60

Sound emitted to exhaust air duct

Fan setting %	Sound power level broken down into octave bands, $L_{w_{okt}}$ dB								Weighted sound power level L_{WA} dB(A)
	63 Hz	125 Hz	250 Hz	500 Hz	1,000 Hz	2,000 Hz	4,000 Hz	8,000 Hz	
40	59	57	47	43	42	37	28	17	47
50	65	63	54	48	47	40	36	24	53
60	70	68	58	52	50	45	41	30	57
70	68	71	62	56	53	49	45	35	61
80	78	74	66	60	56	52	49	40	64
90	79	77	70	62	57	55	51	42	67
100	79	77	71	64	58	56	52	44	68

Sound emitted to kitchen bypass duct

Fan setting %	Sound power level broken down into octave bands, L_{wokt} dB								Weighted sound power level L_{WA} dB(A)
	63 Hz	125 Hz	250 Hz	500 Hz	1,000 Hz	2,000 Hz	4,000 Hz	8,000 Hz	
40	-	42	42	37	33	32	19	-	40
50	58	54	50	43	39	34	27	12	46
60	56	59	55	46	43	38	33	20	51
70	59	62	59	49	45	42	37	25	54
80	-	65	63	49	48	45	41	30	57
90	-	67	66	53	50	48	43	32	60
100	66	69	67	54	50	48	44	34	61

Sound emitted to the surroundings

Fan setting %	Sound power level broken down into octave bands, L_{wokt} dB								Weighted sound power level L_{WA} dB(A)
	63 Hz	125 Hz	250 Hz	500 Hz	1,000 Hz	2,000 Hz	4,000 Hz	8,000 Hz	
40	42	44	37	25	27	19	-	10	33
50	44	46	43	32	25	22	12	-	37
60	43	50	45	35	27	26	18	11	39
70	64	53	46	34	29	29	22	11	43
80	65	55	49	35	31	32	25	11	45
90	66	58	51	39	33	34	28	13	47
100	62	60	53	40	37	36	29	14	48

9.3 Connection outputs

	W100 EC	W100 EC Econo
Connection	230 V, 50 Hz, 7.6 A	230 V, 50 Hz, 5.4 A
Fans	289 W	289 W
Air heater, preheating	1000 W	1000 W
Air heater, reheat	500 W	-
Total output	1,800 W	1,300 W
Fuse protection	10 A	10 A

9.4 Sizing of the water-heated air heater

Inlet flow water °C	Water flow l/h	Airflow, l/s Air flow m ³ /h Capacity W		
		40 144	60 216	80 288
35	40	260	310	330
	80	360	430	470
	150	400	490	560
	220	420	520	600
50	40	450	540	580
	80	590	710	790
	150	650	810	920
	220	680	840	980
70	40	730	860	930
	80	890	1070	1230
	150	1000	1130	1410
	220	1040	1280	1490

9.5 Pressure loss in the air heater for reheat

Swegon CASA W100 Econo Pressure loss in air heater

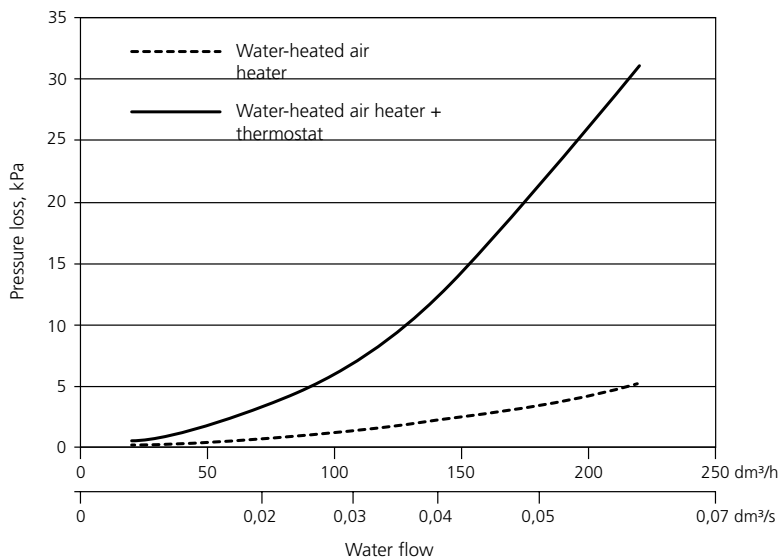

9.6 Electrical wiring diagram

9.6.1 Ventilation unit

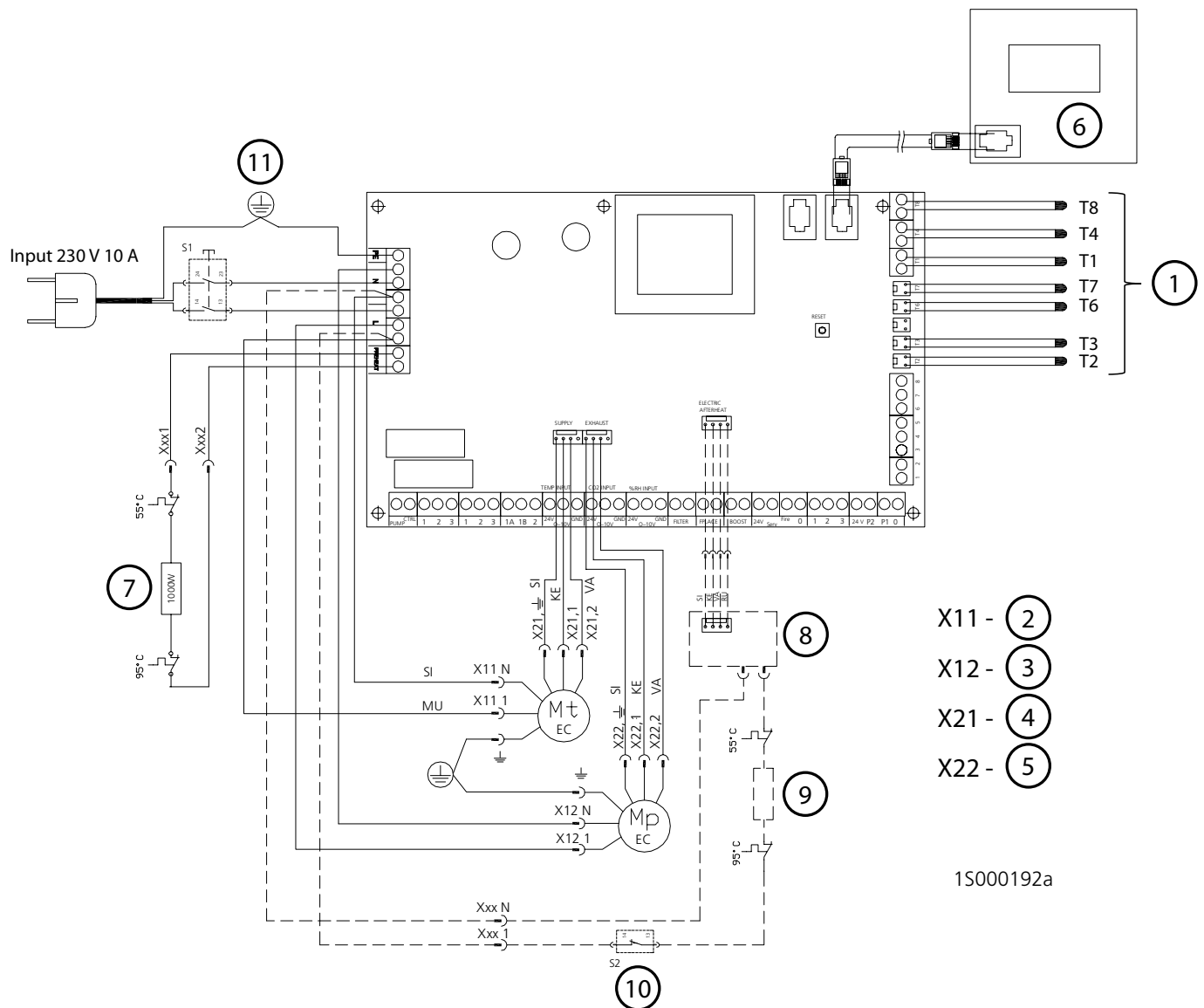

Air heater for reheat for electrically heated models, not Econo

1. Temperature sensor, see the Control diagram
2. Supply air fan plug contact
3. Extract air fan's finger connection
4. Supply air fan's DC contact
5. Extract air fan's DC contact
6. Control panel
7. Air heater, preheat, 1,000 W
8. Triac controller
9. Air heater, reheat, 500 W
10. Contact for bypass past the heat exchanger.
11. Inspection panel switch

9.6.2 Control functions with optional items of equipment

Priority 1: Commands from outer sensor or the ventilation unit's protective functions.

Priority 2: External supervision (DDC).

Priority 3: normal operation from the control panel or the cooker hood.

To connect the modular cable.

Control priority 3

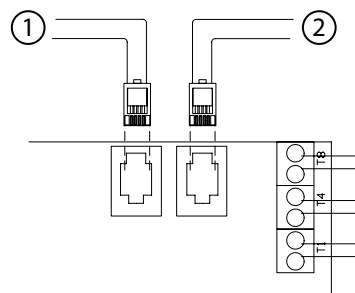

- 1. To cooker hood, control panel or Modbus gateway
- 2. To cooker hood, control panel or Modbus gateway

Control priority 1

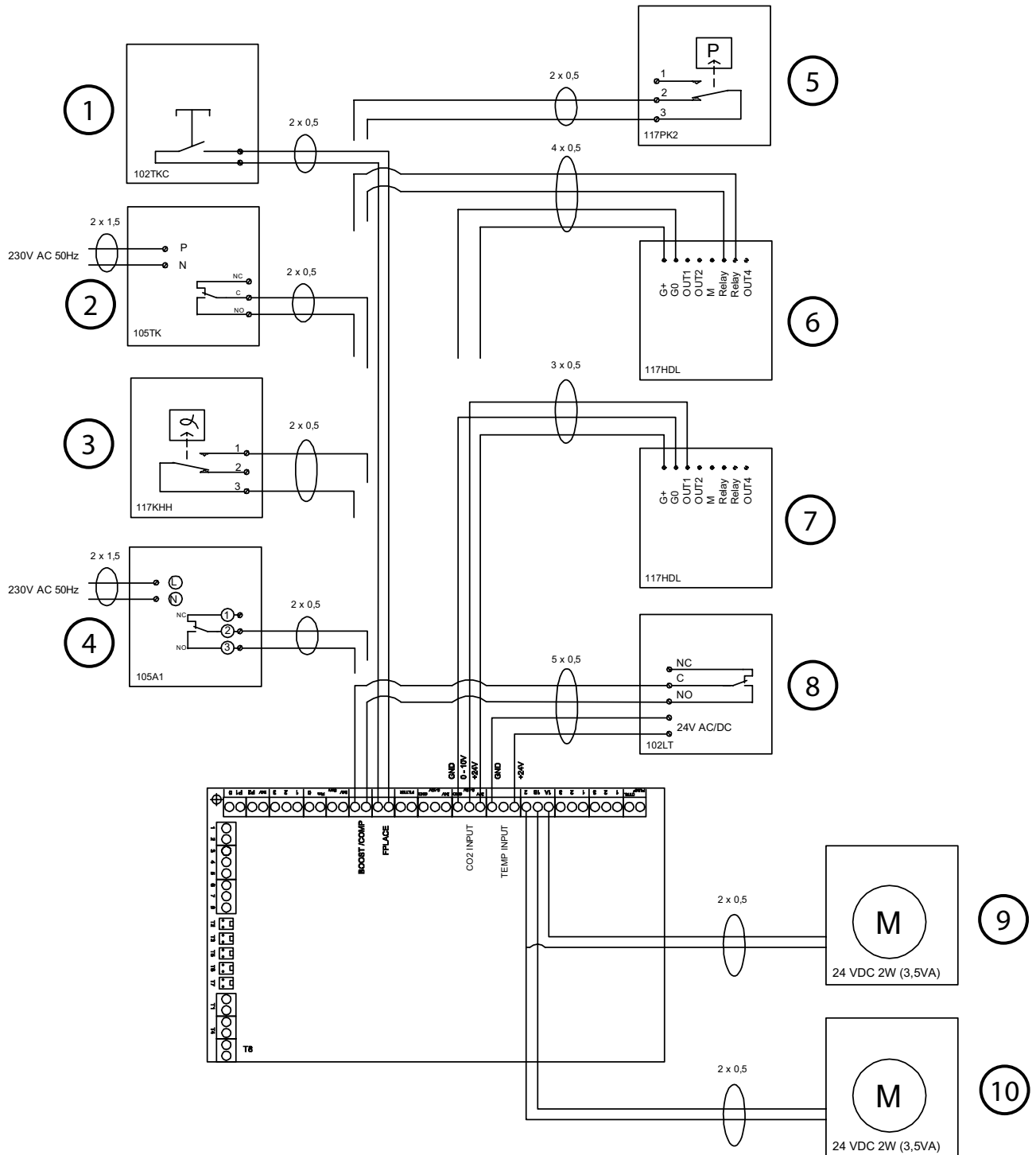

1. Fireplace switch
2. Boost timer*
3. Humidity sensor
4. Timer
5. Sensor for negative pressure compensation*
6. CO₂ sensor with relay
7. CO₂ sensor
8. Presence detector
9. Damper actuator for duct damper – A outdoor air duct**
10. Damper actuator for duct damper – B exhaust air duct**

*) Connect any of the functions, negative pressure compensation or boost to the BOOST/COMP contact. One of the separate functions can also be wired to Input 4 on the DDC wiring terminal row. See DDC.

***) The use of the duct damper should be judged on the basis of the specific case. The use of the duct damper is recommended at least in the outdoor air duct, especially on the Econo models.

Supervision (DDC)

Control priority 2

- The functions of wiring terminals 2-5 can be activated/deactivated from the control panel service menu.
- The status outputs (terminals 6 and 7) can always be used

8: 0 V (GND)

7: The supply air temperature actual value: 0-10 V DC (corresponds to 10–30 °C)

6: Actual value for fan speed: 0–10 V DC

5: The supply air temperature 0-10 V DC control (corresponds to 10–30 °C)

4: 0–10 VDC fan speed control*

3: Alarm – signal from the ventilation unit (earthed contact)

2: Emergency stop (if contact between terminals 1-2 is broken, the ventilation unit will stop).

1: 0 V (GND)

*) Voltages for fan speed control

Speed 1 = 1–2.9 VDC

Speed 2 = 3–4.9 VDC

Speed 3 = 5–6.9 VDC

Speed 4 = 7–8.9 VDC

Speed 5 = 9–max. 24 V DC

Control priority 3

0-0.9 V DC

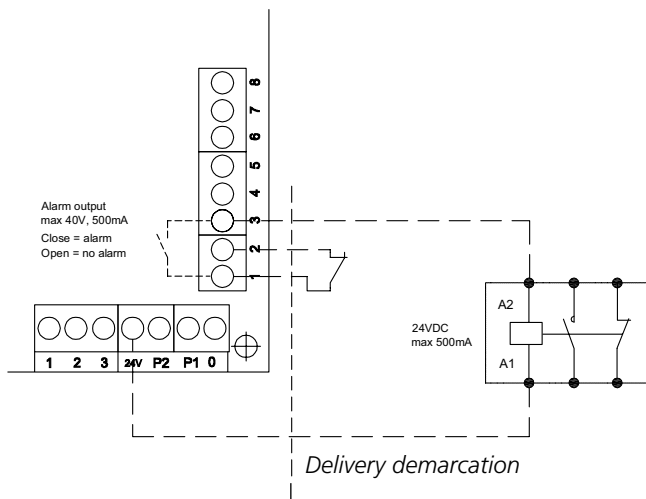

Separate function via DDC terminal row (e.g. Home/Away switch)

The following changes should be made in the functional parameters of the ventilation unit using the Premium control panel:

- Change the fan speed in the Boost mode from speed **5** to speed **4** from the menu: **Installation and service/Fan speeds/Situations**.
- Set the separate supply and extract airflow functions to speed**5** from the menu: **Installation and service/Fan speeds/Speeds**.
- Activate control of the fan speed via DDC from the: **Installation and service/Control/DDC/Fan control system**.

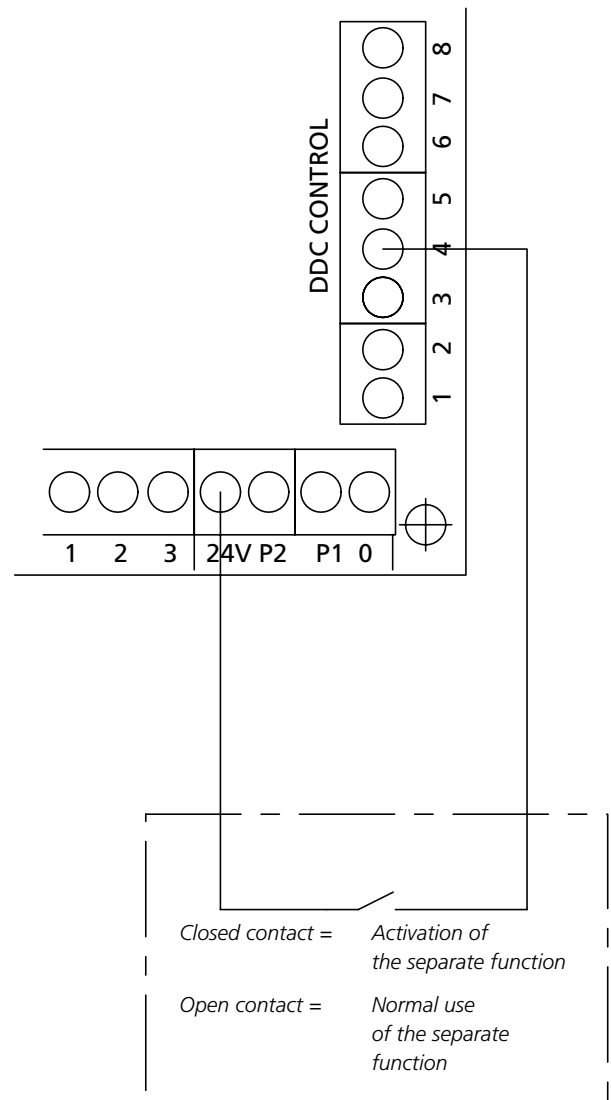

9.7 Control diagram

9.7.1 W100 EC

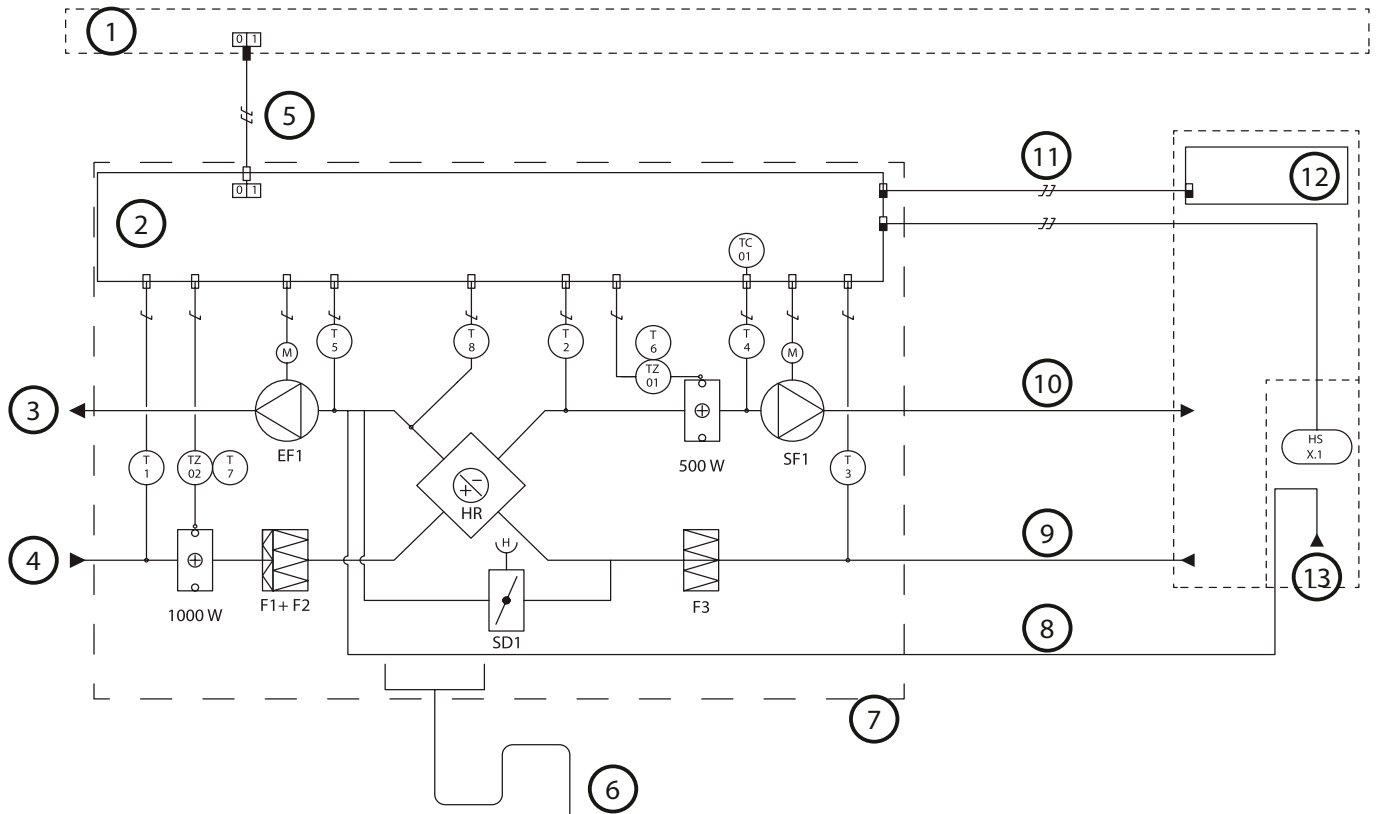

1: Group electrical distribution box | 2: Electrical equipment cubicle | 3: Exhaust air | 4: Outdoor air | 5: Power supply: 230 V, 10 A with plug-in connection | 6: The damming height of the water trap, 100 mm | 7: Supply demarcation of the ventilation unit | 8: Extract air from cooker hood, bypasses the heat exchanger | 9: Extract air | 10: Supply air | 11: Modular cable with RJ9 connector, standard length (pipe with min. Ø20 mm for installation) | 12: Control panel: | 13: Cooker hood

SYMBOL	DESIGNATION	EXPLANATION
T1	TEMPERATURE SENSOR	Temperature sensor, outdoor air
T2	TEMPERATURE SENSOR	Temperature sensor, supply air
T3	TEMPERATURE SENSOR	Temperature sensor, extract air
T4	TEMPERATURE SENSOR	Temperature sensor, supply air, reheating
T6	TEMPERATURE SENSOR	Excess temperature sensor for the reheating air heater
T7	TEMPERATURE SENSOR	Excess temperature sensor for the preheating air heater
T8	TEMPERATURE SENSOR	Temperature sensor, exhaust air, freeze protection
TZ01	OVERHEATING PROTECTION	Overheating protection with manual reset
TZ02	OVERHEATING PROTECTION	Overheating protection with manual reset
HSx.1	MANUAL TIMER SWITCH	Control of the fans and the cooker hood damper

DESCRIPTION OF THE FUNCTIONS

CONTROL FUNCTIONS:

The ventilation unit can be operated from a separate Premium control panel or a Premium cooker hood.

When the ventilation unit is controlled from the cooker hood in the Home/Away/Boost modes and for local extraction, the time can be set to 30, 60 or 120 minutes.

The temperature of the supply air is controlled from the Premium control panel. When necessary, the reheating function can also be switched off from the control panel.

Summer operation: In the summer, the bypass cover automatically opens to allow the supply air to flow past the heat exchanger.

- Overheating protection for the reheating air heater: The air heater is equipped with a TC01 automatic thermostat with manual reset (preset limit value: 90 °C) as protection against overheating.
- Overheating protection for the preheating air heater: The air heater is equipped with a TC01 automatic thermostat with manual reset (preset limit value 90 °C) as protection against overheating.
- The fans have automatic overheating protections.

IF THE SAFETY EQUIPMENT TRIPS:

- If an overheating protection with manual reset trips, it can be reset by pressing a reset button above the air heater.
- The automatic overheating protection of the fan will reset itself when the temperature has dropped below the setpoint.

9.7.2 W100 EC Econo

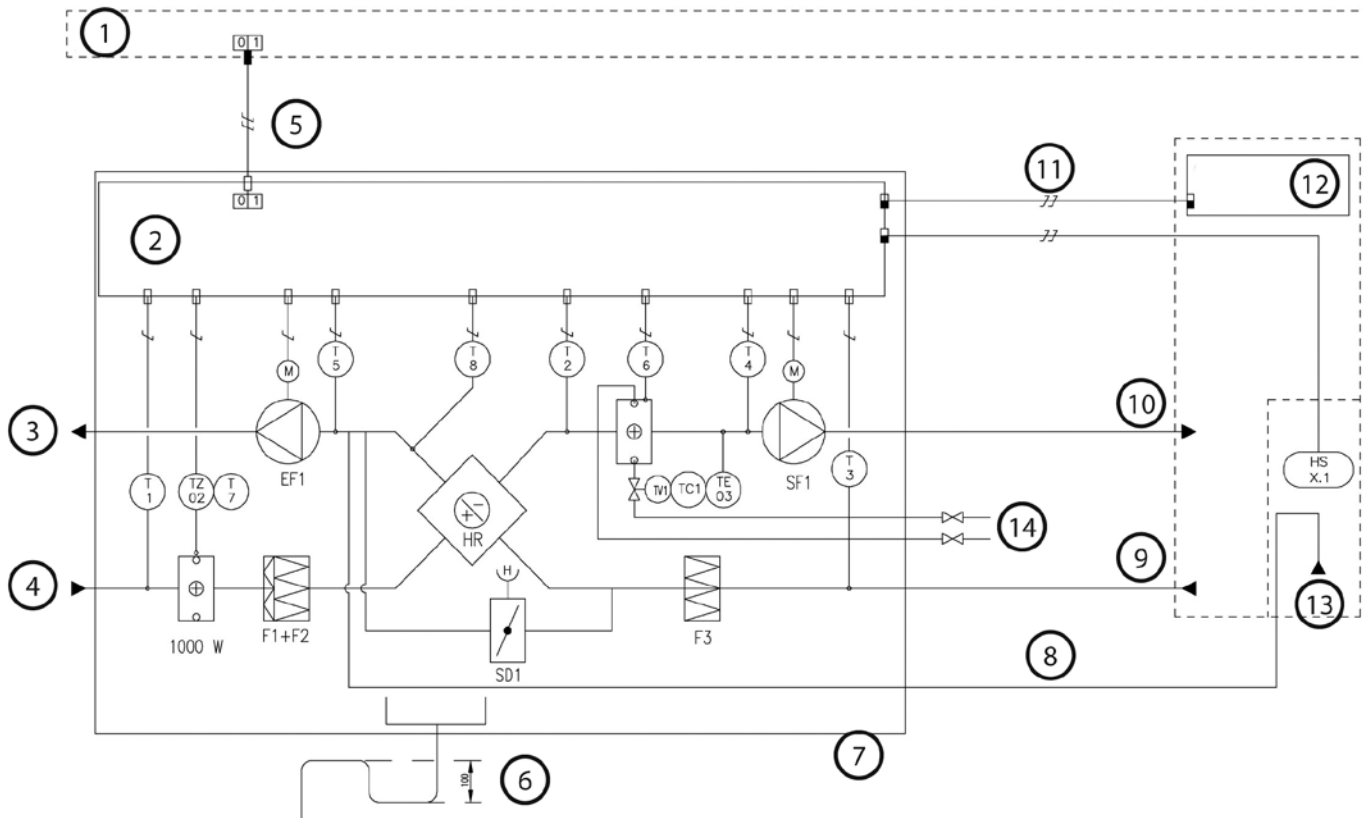

1: Group electrical distribution box | 2: Electrical equipment cubicle | 3: Exhaust air | 4: Outdoor air | 5: Power supply: 230 V, 10 A with plug-in connection | 6: The damming height of the water trap, 100 mm | 7: Supply demarcation of the ventilation unit | 8: Extract air from cooker hood, bypasses the heat exchanger | 9: Extract air | 10: Supply air | 11: Modular cable with RJ9 connector, standard length (pipe with min. Ø20 mm for installation) | 12: Control panel | 13: Cooker hood | 14: E.g. floor heating circuits

SYMBOL	DESIGNATION	EXPLANATION
TC1	TEMPERATURE CONTROLS	Temperature control for the reheating air heater
T1	TEMPERATURE SENSOR	Temperature sensor, outdoor air
T2	TEMPERATURE SENSOR	Temperature sensor, supply air
T3	TEMPERATURE SENSOR	Temperature sensor, extract air
T4	TEMPERATURE SENSOR	Temperature sensor, supply air, reheating
T6	TEMPERATURE SENSOR	The freeze protection sensor of the water-heated air heater
T7	TEMPERATURE SENSOR	Excess temperature sensor for the preheating air heater
T8	TEMPERATURE SENSOR	Temperature sensor, exhaust air, freeze protection
TZ02	OVERHEATING PROTECTION	Overheating protection with manual reset
HSx.1	MANUAL TIMER SWITCH	Control of the fans and the cooker hood damper

DESCRIPTION OF THE FUNCTIONS

CONTROL FUNCTIONS:

The ventilation unit can be operated from a separate Premium control panel or a Premium cooker hood.

When the ventilation unit is controlled from the cooker hood in the Home/Away/Boost modes and for local extraction, the time can be set to 30, 60 or 120 minutes.

The supply air temperature can be set with a mechanical thermostat inside the ventilation unit. Whenever necessary, the reheating function can be switched off by setting the thermostat to the zero setting.

Summer operation: In the summer, the bypass cover automatically opens to allow the supply air to flow past the heat exchanger.

- Overheating protection for the preheating air heater: The air heater is equipped with a TC01 automatic thermostat with manual reset (preset limit value 90 °C) as protection against overheating.

- The water-heated heat exchanger is equipped with a type T6 freeze protection device.

- The fans have automatic overheating protections.

IF THE SAFETY EQUIPMENT TRIPS:

- If an overheating protection with manual reset trips, it can be reset by pressing a reset button above the air heater.

- The automatic overheating protection of the fan will reset itself when the temperature has dropped below the setpoint.

- Frost damage protection a water-heated air heater: Thermostat TC1 will open the heating system's valve completely if the air temperature is lower than 12 °C by the thermostat sensor. If the return water temperature drops 10 °C below the temperature by the type T6 sensor, the controller will switch off the supply air fan. The fan will start again when the supply air temperature has risen above the value preset on the thermostat.

9.8 Dimensions

Swegon CASA W100 R

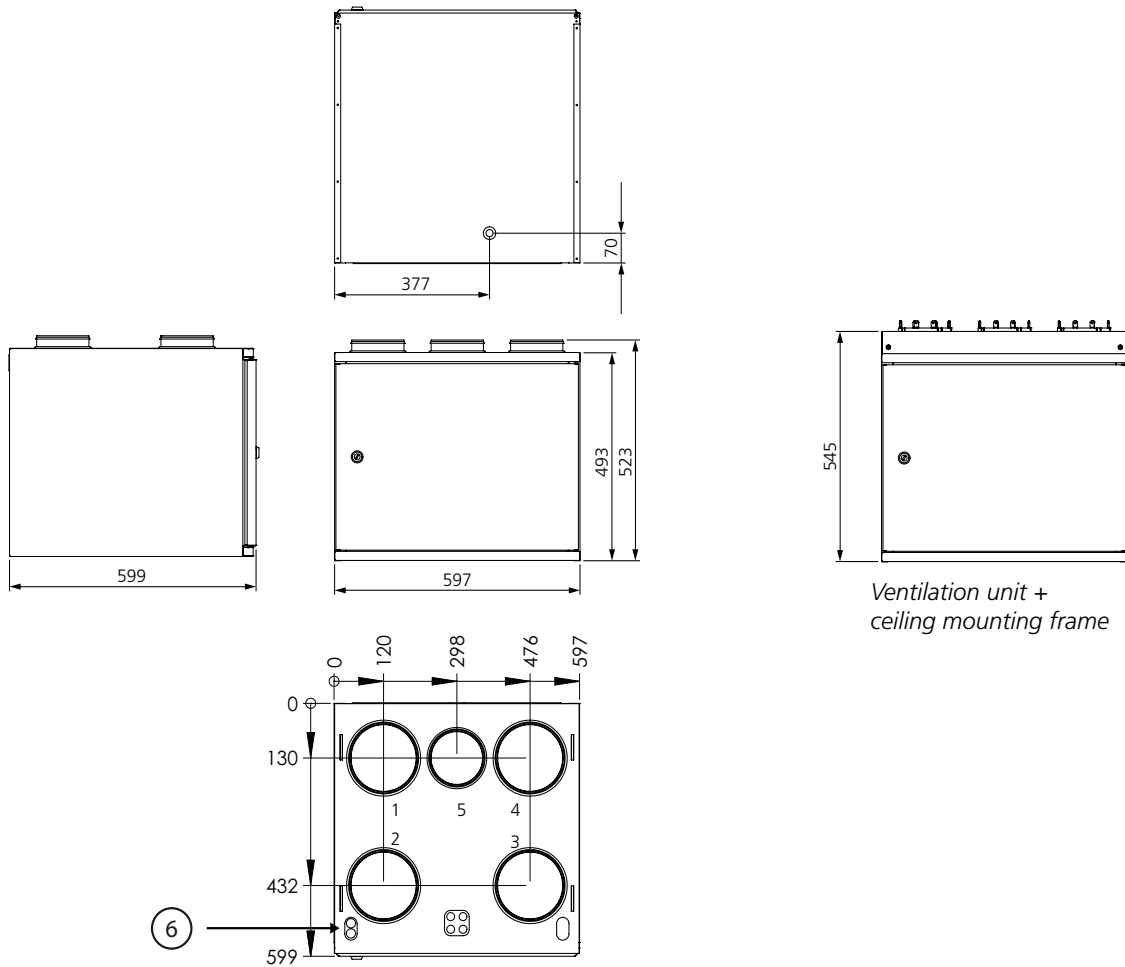

Swegon CASA W100 L

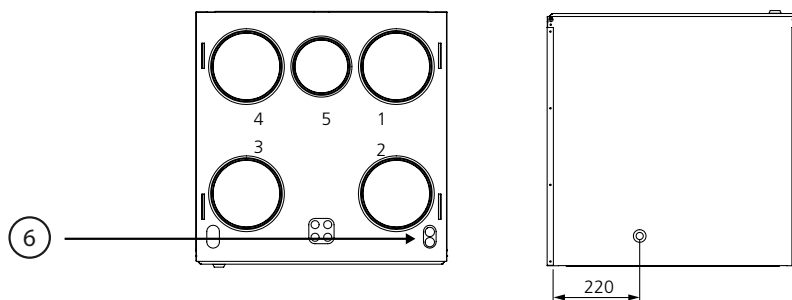

1. Supply air to the home, \varnothing 160 mm
2. Extract air from the home, \varnothing 160 mm
3. Outdoor air to the ventilation unit, \varnothing 160 mm
4. Exhaust air out, \varnothing 160 mm
5. Separate extract air \varnothing 125 mm
6. Radiator connections \varnothing 15 mm

9.8.1 Ventilation unit codes

- W100 Premium (R) PW100SR
- W100 Premium (L) PW100SL
- W100 Premium Econo (R) PW100ER
- W100 Premium Econo (L) PW100EL

9.8.2 Weight

Ventilation unit: 47 kg

9.8.3 Optional items of equipment for installation

- Mounting frame with vapour barrier (R/L) 10280YP
- Ceiling penetration seal for duct, 5 pcs. per package
 - \varnothing 100 mm 102LT10
 - \varnothing 120 mm 102LT12
 - \varnothing 160 mm 102LT16
- Ceiling mounting frame (R/L) PW100KA
- Set of replacement filters PW080FS
 - 1 pc. G3
 - 1 pc. F7
 - 1 pc. PPI-20

10. Commissioning

Function	Factory setting	Setting value
Temperature, supply air (not on the Econo models)	17 °C	
Base display	1	
Time switch clock (timer)	In operation option	
Temperature (not on the Econo models)	In operation option	
Fan speeds (situations).		
Away	1	
Home	3	
Boost	5	
Cool off	4	
Cooling	4	
Heating	3	
Fan speeds		
Speed 1, supply air fan	50 %	
Speed 1, extract air fan	50 %	
Speed 2, supply air fan	60 %	
Speed 2, extract air fan	60 %	
Speed 3, supply air fan	70 %	
Speed 3, extract air fan	70 %	
Speed 4, supply air fan	85 %	
Speed 4, extract air fan	85 %	
Speed 5, supply air fan	100 %	
Speed 5, extract air fan	100 %	
Negative pressure compensation	Off	
Service reminder	In operation option	
Interval	6 months	
Heat (not on the Econo models)	In operation option	
Temp. limitation	50 °C	
Control	Supply air controlled	
Filter guard not W100)	In operation option	
Fireplace switch function (with fireplace switch)	Off	
Boost (with boost timer or presence detector)	In operation option	
Outdoor temperature limit, for activation of air heater	15 °C	

Airflows	Project planning values	Setting value
Supply air, total	l/s m³/h	l/s m³/h
Away		
Home		
Boost		
Extract air, total	l/s m³/h	l/s m³/h
Away		
Home		
Boost		

Other comments

Data for the ventilation unit
Write down the data on the ventilation unit identification plate for reference when the need arises to contact a service company.

Preset by:	Date:

 **The supply airflow must be 5-10 % lower than the extract airflow.**

 **Remember to explain the use of the item of optional equipment and how to service it to the user/caretaker!**

Warranty Conditions

WARRANTOR

Swegon ILTO Oy
Asessorinkatu 10, FI-20780 St. KARINS, Finland.

WARRANTY PERIOD

The product has a two (2) year warranty as from the date of purchase.

SCOPE OF THE WARRANTY

The warranty covers defects that have arisen during the warranty period, which have been reported to the manufacturer, or been declared by the warrantor or a representative of the warrantor, and which refers to design, manufacture or material defects as well as consequential defects that have arisen on the product itself. The above mentioned defects are to be cleared by putting the product in working order.

GENERAL WARRANTY LIMITATIONS

The warrantor's warranty liability is limited in accordance with these warranty conditions and the warranty does not cover damages to property or personal injury. The warrantor is not bound to comply with verbal promises in addition to this warranty agreement.

LIMITATIONS ON WARRANTY LIABILITY

This warranty is granted on condition that the product is used in a normal way or under comparable circumstances for the intended purpose, and that the instructions for use have been observed.

The warranty does not cover faults that have been caused by the following:

- Transport of the product.
- Careless use or overloading the product.
- Failure to follow the instructions dealing with installation, operation, maintenance and care.
- Incorrect installation of the product or incorrect location at the place where it is used.
- Circumstances which are not the fault of the warrantor, such as excessive variations in voltage, damage by lightning and fire or other accidents.
- Repairs, maintenance or design modifications that have been done by unauthorized parties.
- The warranty does not cover insignificant defects from an operational standpoint such as scratches on surfaces.
- Parts, which through handling or normal wear are exposed to a greater than normal risk of failure, such as lamps, glass, porcelain, paper and plastic parts as well as fuses are not covered by the guarantee.
- The guarantee does not cover settings, information about usage, maintenance, service or cleaning which is normally described in the instructions for use or the work required to rectify faults caused by the user neglecting to observe the warning or installation instructions, or investigation of such.

CHARGES DURING THE WARRANTY PERIOD

The authorized service partner will not charge the client for repairs, replaced parts, repair work, transport or travelling expenses necessary for carrying out the repair work that are within the scope of the warranty.

This however assumes the following:

- The defective parts are handed over to the authorized service partner.
- that the repair begins and the work is carried out during normal working hours. The authorized service partner has the right to charge the client for extra costs for urgent repairs, or repairs carried out outside of normal working hours. However if the defects may cause a health risk or substantial economic losses, the defects will be repaired immediately without extra charge.
- A service vehicle or public means of transportation that follows a timetable (boats, airplanes or snow vehicles are not considered public means of transportation) can be used in conjunction with the repair of the product or replacement of defective parts.
- The costs for dismantling and installation of equipment, which is securely mounted to the place where it is used, cannot be considered as being abnormal.

REMEDIAL MEASURES WHEN A FAULT HAS BEEN DISCOVERED

If a defect is discovered during the warranty period, the client must without delay report the defect to the dealer or to an authorized service partner (www.swegon.com/casa). Specify which product has a fault (product model, type designation on the warranty card or on the product identification plate, serial number); describe the type of fault as accurately as possible, and the circumstances under which the fault has arisen. If there is risk that the fault may have consequential impact on the environment, the ventilation unit must be switched off immediately.

A prerequisite for valid warranty liability is that the manufacturer or a representative of the manufacturer is given opportunity to inspect the defects reported in the warranty claim before the repair work begins. A prerequisite for repair under warranty is also that the client, in a satisfactory manner, can prove that the warranty is valid (= written receipt of purchase). After the guarantee period has expired, guarantee claims, which have not been submitted in writing prior to the expiration date of the guarantee period, are not valid.

Swegon ILTO Oy, Asessorinkatu 10, FIN-20780 St Karins, Finland, www.swegon.com/casa, unit.warranty@swegon.fi

EG Compliancy Declaration

We at:

Swegon ILTO Oy
Asessorinkatu 10
20780 S:t Karins, Finland
FINLAND

We hereby affirm that

the Swegon CASA ventilation units

comply with the following EC Directives:

The machinery Directive (2006/42/EC)
Low Voltage Directive (2006/95/EC)
The EMC Directive (2004/108/EC)

and that the following harmonised standards have been applied:

EN 60335-1:2002 +A1:2004 +A11:2004 +A12:2006 +A13:2008 +A14:2010 +A15:2011 +A2:2006
EN 60204-1:2006 +A1:2009
EN 60034-5:2001 +A1:2007
EN 55014-1:2006 +A1:2009
EN 55014-2:1997 +A1:2001 +A2:2008
EN 61000-3-2:2006 +A1:2009 +A2:2009
EN 61000-3-3:2008

Person authorised to compile the technical documentation:

Name: Rami Wiberg
Address: Asessorinkatu 10, 20780 S:t Karins, Finland
E-mail: rami.wiberg@ilto.fi

Date: Kaarina 02.07.12

Signature:



Peter Stenström
CEO
Swegon ILTO Oy

N.B.! The document's original language is English.

