

ADAPT Damper

Room product for Swegon's WISE System for demand-controlled ventilation



QUICK FACTS

- Integrated temperature sensor
- Modbus RTU-communication
- Simple wiring: Plug and Play
- Available as a package solution for energy saving in schools: School WISE
- Clean Air Control CAC (option)
- Detector module DETECT SME (accessory)

QUICK SELECTION

Product with sound attenuator	q(l/s)			Cooling capacity (W) (ΔT 8K)			dB(A) nom*	
	min	nom	1 Pa/m	min	nom	1 Pa/m	50 Pa (P_{tot})	80 Pa (P_{tot})
ADAPT Damper 125	0/4	35	38	40	340	365	≤ 35	≤ 38
ADAPT Damper 160	0/6	70	70	60	670	670	≤ 30	≤ 32
ADAPT Damper 200	0/10	140	140	100	1340	1340	≤ 30	≤ 32
ADAPT Damper 250	0/15	240	240	145	2300	2300	≤ 30	≤ 32
ADAPT Damper 315	0/25	430	430	240	4130	4130	≤ 30	≤ 32
ADAPT Damper 400	0/40	750	800	380	7200	7680	≤ 30	≤ 32
ADAPT Damper 500	0/60	1200	1500	575	11520	14400	≤ 30	≤ 32

* dB (A) values are approximate and are based on one or several ceiling air diffusers with insulated commissioning box in a normally sound-attenuated room. Calculations have been made with a 500 mm long CLA downstream of the damper. Size of the room is based on an airflow of approx. 8 l/s m² alt. 80 W/m². NOTE: The acoustic data should be used as guidelines only. Acoustic calculations are advisable for obtaining precise acoustic data.

Contents

Quick facts 1

Technical description 3

Design 3

CONNECT Adapt 3

Functions: 3

Air quality control, CAC 3

Humidity controll 3

Materials and finish..... 3

Planning..... 4

Installation 5

Commissioning 5

Maintenance..... 5

Declaration 5

Electrical data..... 5

Sizing 6

Airflow - Pressure drop - Sound level..... 6

Acoustic data for ADAPT Damper 6

Dimensions and weights 7

Ordering key 7

Accessories..... 8

DETECT Quality..... 8

DETECT SME presence detector 9

DETECT Occupancy..... 10

TUNE Adapt..... 11

TUNE Temp..... 11

LINK Modbus..... 11

LINK Tuneadapt 11

FSR clamp 13

ACTUATOR 14

Technical description

Design

ADAPT Damper is a flow-controlled damper which is a part of Swegon's WISE system. The damper regulates the air stream to the correct airflow based on preset absence, min. and max. flows. ADAPT Damper is equipped with an integrated controller for all the relevant set values and control functions. The damper also includes a built-in temperature sensor for measuring the supply air and extract air flows.

The damper can close or open completely in response to signals from a main control system, a so-called emergency state function.

The circular sizes have a damper that can shut off the airflow to tightness class 3.

CONNECT Adapt

A connection box, CONNECT Adapt, is included in every damper delivery (Master), figure 2. The connection box replaces the coupling box which otherwise is mounted on a wall/ceiling for wiring damper with 24 V incoming voltage.

Both damper and box are equipped with RJ45 quick-fit connector for quick and fault-free wiring. The device has provision for connection to a main control system (BMS) via ModBus. Connect the LINK Modbus accessory cable (RJ12) between damper and box and the device is ready for the main control system. The following control functions can also be connected from the connection box:

Heating in sequence, CO₂-sensor, set point selector, external presence detector and Rh-sensor. If the presence detector is switched in, the presence signal can be fetched for controlling the lighting, for instance, and in this way save more energy.

Functions:

- Cools/heats and ventilates with air
- Two stage cooling with water in the second stage, cannot be combined with heating
- Controls airflows with regard to temperature through the accessories DETECT SME or DETECT Temp.
- Controls airflows with regard to presence through the accessories DETECT SME or DETECT Temp.
- Provision for switching in a presence detector
- Available in version with air quality control, CAC
- Ventilation boost after long period of vacancy
- Provision for wiring to a CO₂-controller
- Provision for wiring to a Rh-controller
- Provision for the manual setting of set points
- Has provision for connection to a main control system (ModBus)
- Control of heating in sequence if two-stage cooling has not been selected
- Performance check with Tune ADAPT. Connects into the socket of ADAPT Damper for testing damper components.
- Performance check with DETECT SME, alarm via LED if some component in the device is faulty or alternatively by connecting Tune ADAPT into DETECT SME.
- Comfort control through the presence detector DETECT SME or Tune ADAPT, connected to the output socket of ADAPT Damper. Alarm is emitted via LED or display if room temperature or CO₂ values deviate too much from their set values. The function is not activated at delivery.

Air quality control, CAC

CAC, "Clean Air Control" is a gas mixture sensor that measures the room's contamination degree. CAC controls ventilation flow to preset adjustable limits. For more information about the sensor, see separate document at www.swegon.com.

Air quality control

DETECT Quality is an external electronic CO₂ detector, used with ADAPT Damper for supply air and for controlling ventilation needs within the premises.

Humidity control

DETECT Rh is an external electronic Rh-sensor. It is used with ADAPT Damper to control the need of ventilation in a building.

Materials and finish

ADAPT Damper is made of galvanized sheet steel and has parts made of plastic, rubber. ADAPT DAMPER also contains electronic components. The connection box is made of ABS plastic.

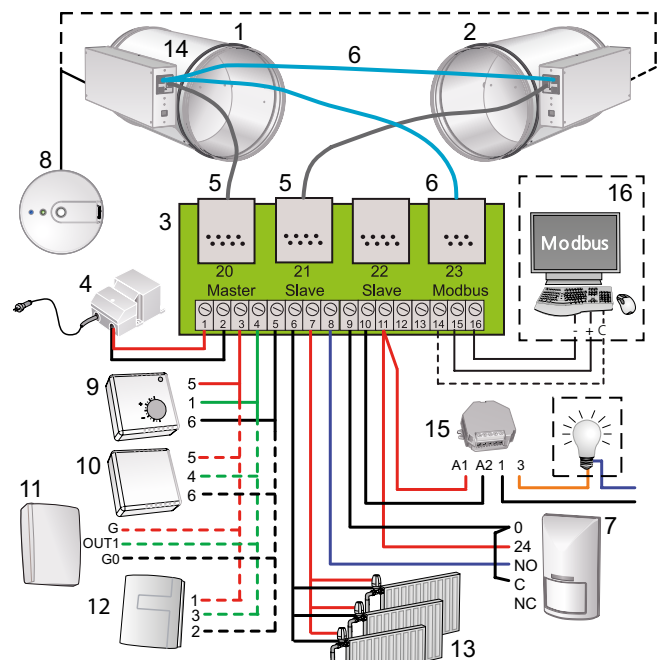

Figure 1. Wiring of master/slave-units and accessories.

1. ADAPT Damper, Master unit (3VA).
 2. ADAPT Damper, Slave unit (3VA).
 3. CONNECT Adapt (conn. terminal).
 4. POWER Adapt 230-24 V AC transformer.
 5. LINK Adapt 5 m (RJ45 cable).
 6. LINK Modbus 5 m (RJ 12 cable).
 7. DETECT Occupancy (1 VA).
 8. DETECT SME, Presence detector. Function control, temperature and occupancy detection.
 9. *)TUNE Temp (Can be combined with DETECT SME).
 10. *)DETECT Temp (Redundant when DETECT SME is chosen).
 11. *)DETECT Quality (Can be combined with DETECT SME).
 12. *)Detect RH, moisture sensor (Can be combined with DETECT SME)
 13. ACTUATOR, radiator- or cooling unit regulation (24V PWM), max 3 valves, each at 6 VA.
 14. SPLIT Link RJ12, branching for Modbus cable.
 15. ADAPT Relay 24 V AC for lighting (<1 VA).
 16. Modbus RTU, connection to zone damper or router.
- *)9, 10, 11 and 12 cannot be combined.

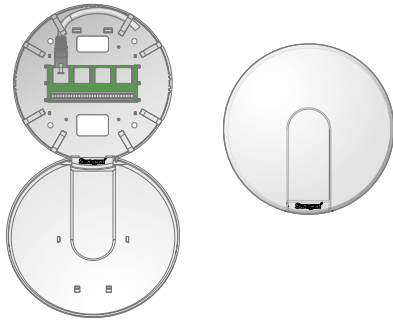

Figure 2. CONNECT Adapt with concealed quick-fit connectors and connection terminals.

Planning

ADAPT Damper sets itself to the correct airflow between preset min. and max. values based on applicable set points and sensor information. Available pressure must not exceed 250 Pa. Max airflow is chosen with the damper open to max 80%. The pressure drop upstream of the damper must be considered with respect to sound levels. See the sizing diagrams or quick selection tables. Even if the dampers are flow-controlled, pressure control is needed for each zone. This can be done either by the air handling unit in smaller systems, or by CONTROL Zone in larger systems. In installations with supply air damper only, these must be supplemented with DETECT T. For further planning instructions, see the Technical Section.

For further planning directions, see the section: WISE System Engineering.

Installation example:

Conference room with variable airflow

- Option 1 Control of temperature only by means of an integrated temperature sensor in the extract air damper.
- Option 2 The addition of a presence detector and provision for absence set points (flows, temperatures).
- Option 3 Control of the air quality with the CAC clean air function.

School WISE

Many of today's schools are ventilated with constant airflows. Substantial energy and money can be saved if these systems are replaced with variable airflow systems.

The School WISE package is a complete kit for a normal classroom. All the component parts (except the presence detector) can either be fitted in the corridor which makes installation possible all year round, or the installation work can be done inside the classroom.

The zone, of which the classroom is part, must be pressure controlled for the function required. For further planning instructions, see the Technical Section.

- 2 pc ADAPT Damper Ø315, preset to 40-300 l/s, the master damper (located in the extract airflow) is equipped with the CAC function, as standard.
- 2 pc LINK Adapt, RJ45 cable for wiring, L=5 m
- DETECT Occupancy
- Cable L=10 m to DETECT Occupancy
- Connection box, CONNECT Adapt
- 2 pc FSR, clamps

If possible access the classroom's supply air and extract air ducts from the corridor when you install the dampers. This way you will avoid disturbing the students and teacher holding class. Install the master damper on the extract air duct. The room airflows are regulated with regard to temperature and air quality. The installation of a presence detector also makes it possible to use airflows and temperatures while there are no occupants in the room(s). The presence detector can also be used for controlling the lighting, which will save even more energy and money.

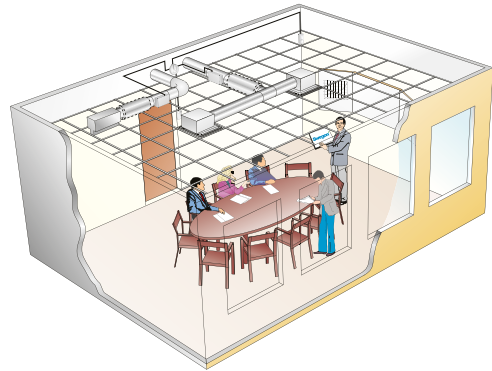

Figure 3. Conference room with variable airflow.

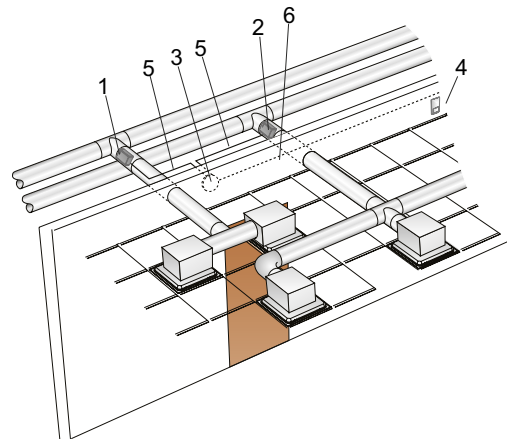

Figure 4. 1. ADAPT Damper 315-M-CAC, Master, extract air
2. ADAPT Damper 315-S, Slave, supply air
3. CONNECT Adapt
4. DETECT Occupancy
5. LINK Adapt 5 m with quick-fit connectors
6. Installation cable, 3 wires, type EKRR



Figure 5. The School WISE package.

Installation

A length of straight duct ≥ 2 times the duct diameter downstream of a duct bend, T-piece or dimensional change is required for correct operation. We recommend installation using an FSR clamp. See Figure 6. The exterior surface of the entire product should be insulated if it is installed in a cold space. To simplify wiring the TUNE Adapt, the LINK Tuneadapt extension cord with terminal box is available for installation in false ceilings. If installed in false ceilings, an inspection hatch is also required to allow inspection of the product.

Commissioning

ADAPT Damper is normally preset at the factory, either with customer-specific or with standard settings.

The TUNE Adapt hand-held terminal is used for manually checking the current airflow through the damper and for changing set points, if required. It can be connected to the appropriate quick-fit contact on the side of the damper. See Figure 8.

Maintenance

ADAPT Damper is maintenance-free. Clean only by wiping with a dry cloth. When cleaning the duct system, the ADAPT Damper must be dismantled for cleaning if there are no inspection covers nearby. Cleaning tools like whisks and the like must not be drawn through the damper.

Declaration

Declaration of Construction Materials is available for download from www.swegon.com.

Electrical data

ADAPT Damper is supplied with power via the connection box. See the wiring diagram.

For more information about various wiring and room solutions, see the Technical Section entitled: System Solutions.

Supply voltage	24 V AC -10% +10% 50-60 Hz
Max. power consumption	3 VA
Cable rating	0.6 A
Ambient temperature:	
In-operation	0°C - +50°C
Storage	-20°C - +50°C

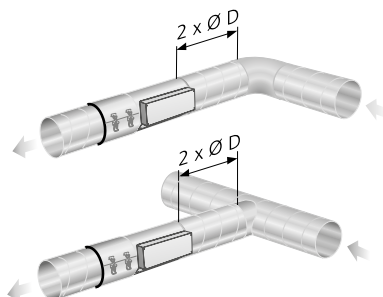

Figure 6. Length of straight duct required upstream of ADAPT Damper to compensate for various obstructions.

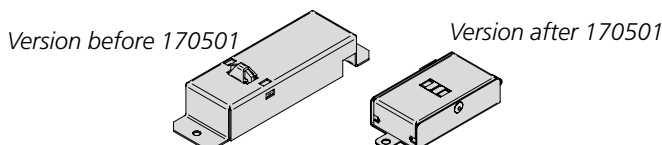

Figure 7. CAC sensor.

Standard settings for default products

Temperatures

Presence	22 °C	± 1 K
Absence	22 °C	+3 / -2 K
Night-time cooling	17 °C	

Air flows m³/h (l/s)	Absence*)	Min. airflow	Max. airflow
Size 125	0/4	8	50
Size 160	0/6	10	80
Size 200	0/10	15	125
Size 250	0/15	25	200
Size 315	0/25	40	300
Size 400	0/40	65	500
Size 500	0/60	100	800

*) Possibility to set 0 as min. flow with the result of fully closing the damper, for older controllers (until version 5.1) the min. flow is 1 l/s which normally gives a closed damper. The second displayed value refers to adjustable flow during absence.

Air quality	Min.	Max.
CAC (%) version before 170501, see fig. 7	25	35
CAC (%) version after 170501, see fig. 7	35	45
CO ₂	800	1000
Rh - Relative humidity (%Rh)	65	90
Presence		
Switch on delay		0 sec.
Switch out delay		20 min.

Communication

Modbus ID	1
Speed	38 400
Word length	8 bits
Stop bits	1
Parity	None

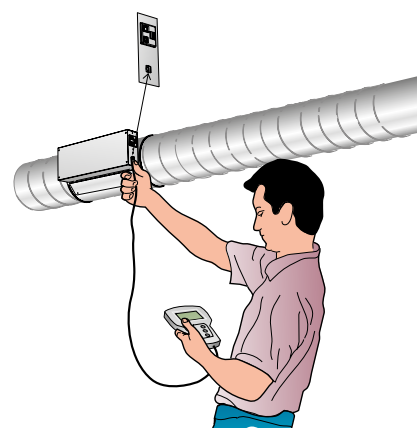

Figure 8. Wiring TUNE Adapt for checking and changing set points. If DETECT SME is chosen as an accessory the TUNE Adapt is connected directly to it.

Sizing

The diagrams for the various sizes show the total generated sound power (L_{Wtot} dB), as a function of the air-flow and pressure drop across the damper. The sound power level for each octave band ($L_W = L_{Wtot} + K_{ok}$) can be obtained by correcting L_{Wtot} with the correction factors from Table 1.

Airflow - Pressure drop - Sound level

1. The data is applicable to flow-generated sound arising in ducts.
2. The flow range of ADAPT Damper is specified in the quick selection table.
3. Specified sound levels L_{Wtot} 50, 55, 60, 65 och 70 dB for lines shown in the diagram.
4. Max. available pressure upstream of the damper ≤ 250 Pa.

Acoustic data for ADAPT Damper

Table 1

Correction factor K_{ok}

Size ADAPT D	Mid-frequency (Octave band) Hz							
	63	125	250	500	1000	2000	4000	8000
125	0	-4	-9	-17	-20	-29	-34	-40
160	0	-4	-9	-19	-22	-27	-35	-39
200	0	-5	-9	-17	-19	-24	-31	-32
250	0	-6	-9	-14	-17	-19	-23	-26
315	0	-4	-10	-14	-17	-21	-28	-29
400	0	-4	-9	-12	-15	-20	-26	-25
500	0	-6	-6	-11	-14	-18	-26	-29
Tol. \pm	2	2	2	2	2	2	2	2

ADAPT Damper 125

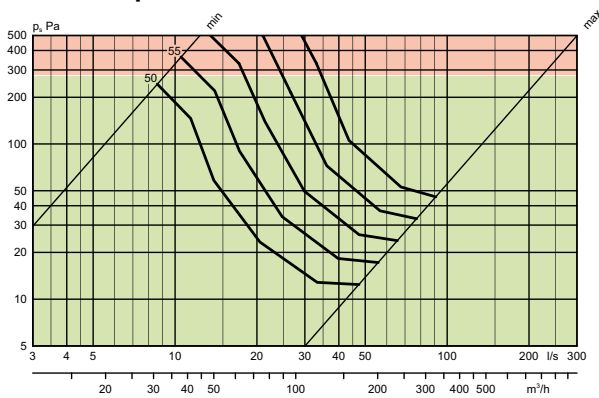

ADAPT Damper 160

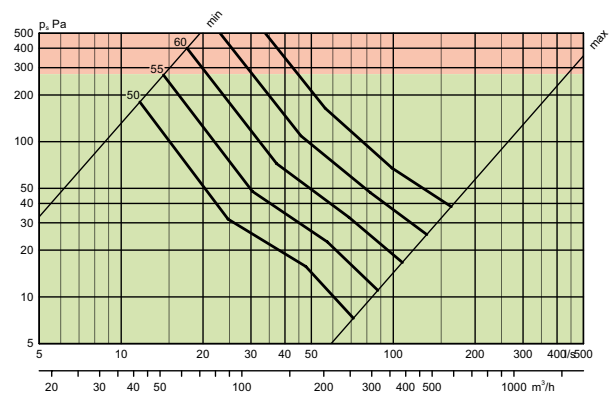

ADAPT Damper 200

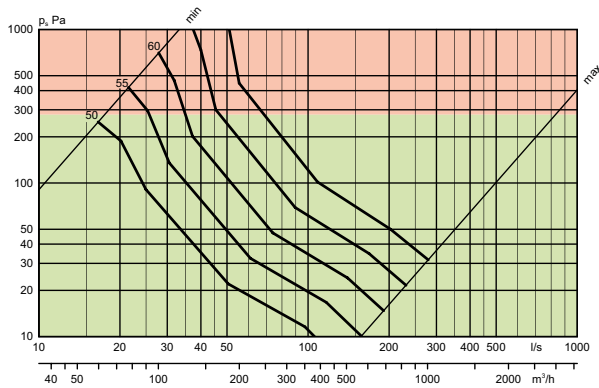

ADAPT Damper 250

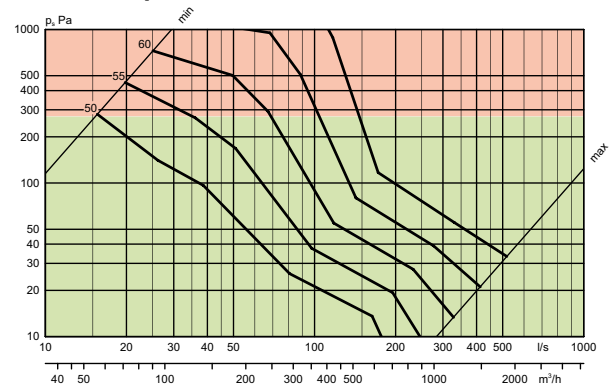

ADAPT Damper 315

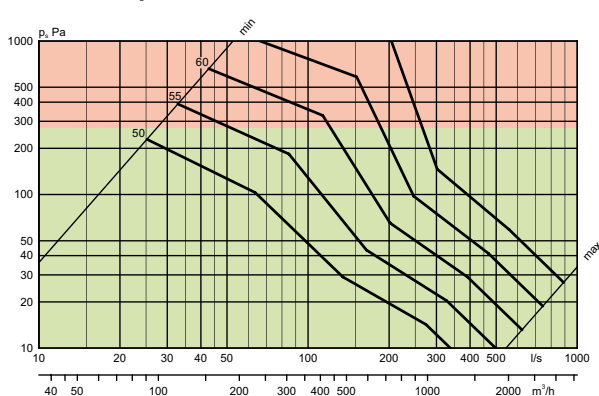

ADAPT Damper 400

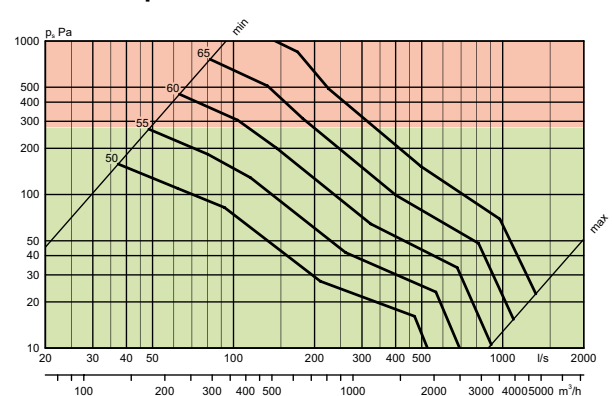

ADAPT Damper 500

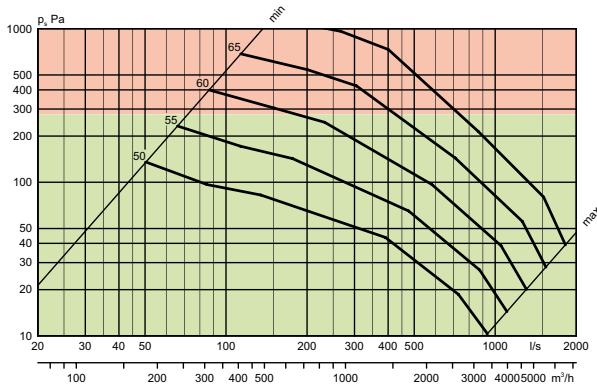

Ordering key

Product

School WISE, complete package School WISE c -aaa

Version:

Size: 200, 250, 315

Circular active room damper ADAPT D d -aaa -b -c

Version

Standard sizes:

125, 160, 200, 250, 315, 400, 500

M = Master

S = Slave

CAC = With CAC air quality control (extract air only)

0 = Without CAC air quality control

N.B.! Specify absence, min./max. airflows in your specification!
The CAC function can be combined with master and extract air only.

Dimensions and weights

ADAPT Damper

Size	Dimensions (mm)						Weight (kg)
	A	C	ØD	E	F	G	
125	572	458	124	75	175	45	3,4
160	572	458	159	75	175	45	3,8
200	572	458	199	75	175	45	4,5
250	572	458	249	75	175	45	5,1
315	572	458	314	75	175	45	6,0
400	826	680	399	75	175	57	9,3
500	826	680	499	75	175	57	11,3

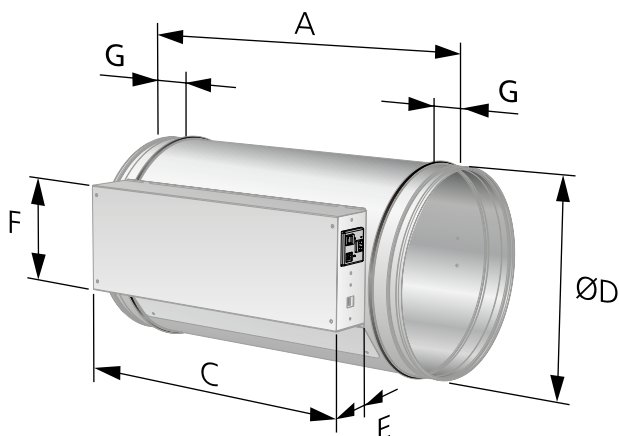

Figure 9. Dimensions, ADAPT Damper.

1 = CAC sensor factory-fitted to the ADAPT Damper xxx-M-CAC.

Accessory

- DETECT Quality Temperature and CO₂ sensor with set point selector knob
- DETECT SME External presence detector
- DETECT Occupancy Type IR presence detector for adjustment between presence and absence
- TUNE Adapt Hand-held terminal for reading/changing settings
- TUNE Temp Temperature adjuster
- DETECT Temp Analogue temperature sensor
- DETECT RH Air quality sensor
- LINK Modbus RJ12-cable for connecting up Modbus RTU
- LINK Tuneadapt Extension cord for outlet to TUNE Adapt
- LINK Adapt RJ45 cable for connecting up in other lengths
- LINK Wise Network cable for Modbus, complies with the EIA/TIA-485 standard
- FIX Link For securing cables to ducts, etc.
- POWER Adapt Transformer
- ACTUATOR Valve actuator, on/off
- VALVE Radiator valve
- ADAPT Relay Lighting control relay
- ADAPT Triac Semiconductor relay for lightning- or heath controll
- FSRb Clamp for installation

Accessories

DETECT Quality

DETECT Quality is an electronic CO₂ sensor used with ADAPT Damper for supply air and for controlling ventilation needs in premises. External presence detector DETECT SME is required for full functionality; performance check, occupancy and room temperature detection. Preset values are managed by ADAPT Damper. As an alternative, there is a CAC function integrated into ADAPT Damper for extract air, which then becomes master.

Quick facts:

- CO₂ sensor
- Measuring range: 0-2000 ppm
- Output signal 0-10 V

Electrical data

Supply voltage	24 V ±20 % AC/DC
Power consumption	3 VA
Ambient temperature	0 °C – +50 °C
Reaction time	2 min.
Humidity	0-95% RH (non-condensing)
Degree of protection, installed in a room	IP 20
OUT1 0-10 V DC	0-2000 ppm

Ordering key

Carbon dioxide sensor	DETECT Q	a	-a
Version:			
Type: Without display:	0		

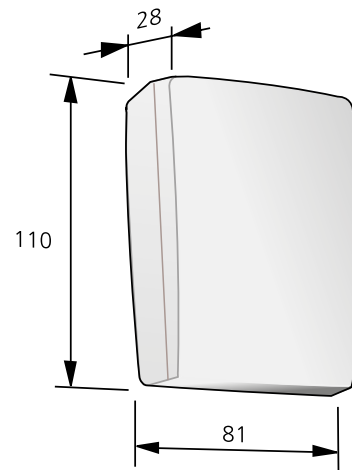

Figure 10. DETECT Q-0

DETECT SME presence detector

DETECT SME is an external module equipped with an occupancy presence detector, temperature sensor, operation indicator and connection for TUNE Adapt hand terminal. The module has limited presence detection, hence importance of placement. In larger rooms the DETECT O is a necessary complement to eliminate blind zones. The presence detector is only intended for surface mounting and must be used with a surface mounted cable duct (not included in delivery).

DETECT SME must not be mounted in locations exposed to sun light, this affects both temperature measurement and presence detection negatively.

Quick facts

- Occupancy presence detector of IR-type
- Room temperature sensor
- LED operation indicator
- Connection for TUNE Adapt
- Delivered with 10 m connection cable

Detection

The presence detector is divided in sectors, 6 placed horizontally and 3 vertically (not shown in figures). For detection to take place, movement between two sectors is required. The further away from the unit this happens, the larger the movement required, as the sectors grow larger with distance. In figure 12, the central sectors are highlighted in green. Sector size corresponds approximately to 1/6 of the value from measurement B.

Electrical data

Power supply via ADAPT Damper

Ambient temperature 0 °C – +50 °C

Degree of protection, installed in a room IP 30

Ordering key

Presence detector DETECT SME a -a -bb

Version:

Type:

1 = Wall mounted

2 = Corner mounted

Connection cable:

10 meters

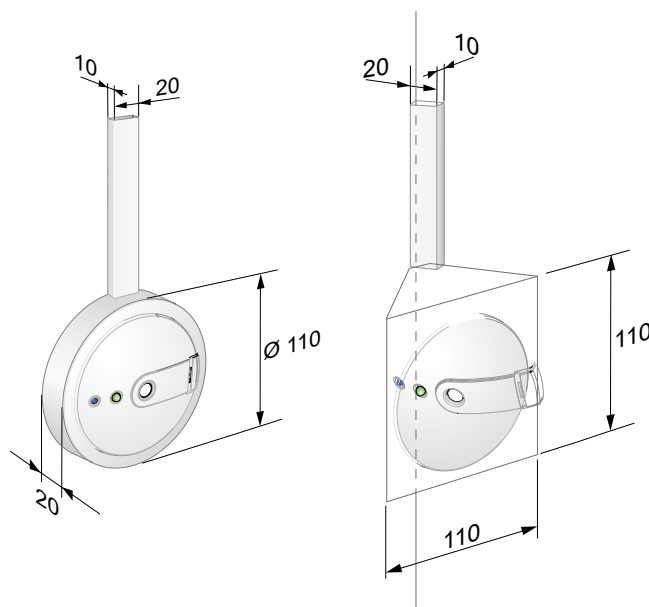

Figure 11. Dimensions for DETECT SME (cable duct is not included in delivery).

Occupancy presence sensor – detection area

A	B	H	B/6
1,5	2,6	3,0	0,4
2,5	4,5	4,0	0,8
4	7,0	5,6	1,2
6	10	7,6	1,7

All measures are displayed in meters.

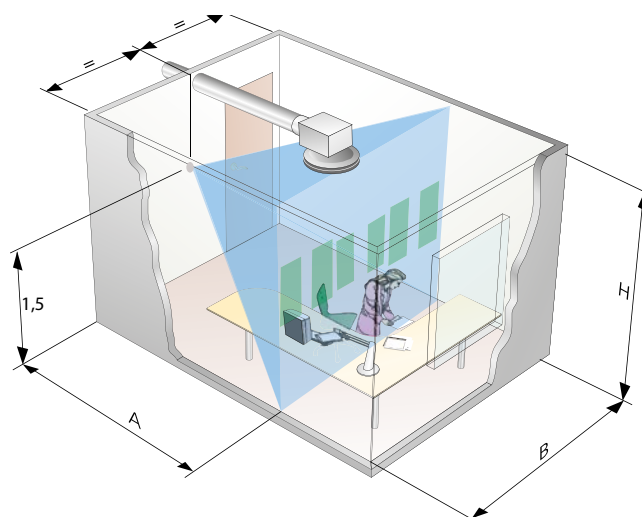

Figure 12. Detection area when DETECT SME is mounted 1,5 m above floor level. The presence detector is placed at the middle of the endwall in the room. Max, recommended room depth is 6 m. Note that the detection width then is 10 meters. Corner mounted version covers the whole room, penetration depth is still max 6 m.

DETECT Occupancy

DETECT Occupancy is an IR type presence detector for use in combination with ADAPT Damper for readjusting between presence and absence of occupants. Adjustable on/off switching delay. Available for wall or ceiling mounting. A mounting bracket that enables angular adjustment of the sensor for optimal coverage of the room is included for the wall-mounted variant.

Quick facts:

- IR detector of double enclosure type
- Available for ceiling or wall installation
- Normally open and normally closed changeover contacts
- Adjustable on/off switching delay
- White enclosure

Electrical data

Supply voltage	24 V ±2 V AC/DC
Power consumption	1 VA
Ambient temperature	-20 °C – +50 °C
Degree of protection, installed in a room	IP 20
Max. detection area	15 x 15 m

Ordering key

DETECT Occupancy presence detector DETECT O a -aaa

Version:

Type:

Wall mounted: V110

Ceiling mounted: T360

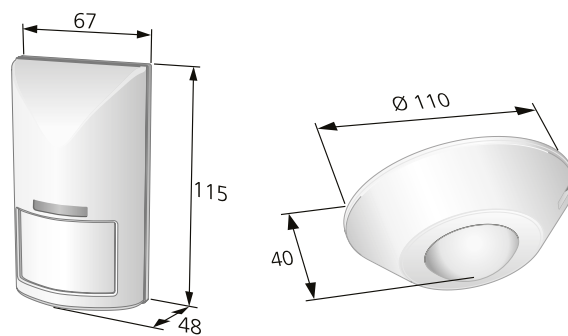

Figure 13. DETECT Occupancy.

Note: Settings of on/off-delay is done in DETECT Oa, settings in ADAPT are not valid.

DETECT Temp

DETECT Temp is an analogue temperature sensor that can be used instead of DETECT SME when:

- ADAPT Damper is master of supply air.
- ADAPT Damper is master of extract air, with heat regulation, while the unit is closed.

Quick facts

- Thermistor for room temperature
- 10-30° C range of application
- 0-10V DC signal out

Electrical data

Supply voltage	24 V AC ±10%
Power consumption	1 VA
Outputs: 0-10 V max load	10 mA
Degree of protection	IP 30

Ordering key

Temperature sensor DETECT T a

Version:

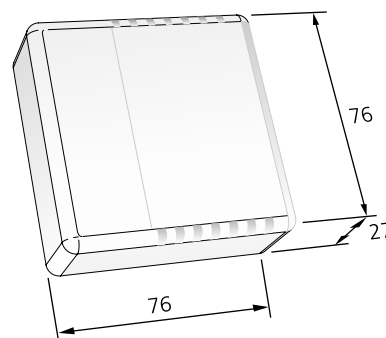

Figure 14. DETECT Temp

TUNE Adapt

Hand-held unit for checking and setting values such as temperatures, CO₂ limits and airflows. Compatibility of the hand-held micro terminal: An older TUNE Adapt can always read all the later versions of the controller, a newer version of TUNE Adapt cannot read older controller variants.

Note: All the ADAPT products with version letter designation b are of Version 5.

- Simple connection directly to the air diffuser
- Supplied with power via the air diffuser
- Illuminated display window
- Simple and logical menu structure



Figure 15. TUNE Adapt

Ordering key

TUNE Adapt hand-held terminal	TUNE A	b	-bbb
Version:			
Language	1 = EN, SE, DK, FI, NO		
	2 = EN, RU, PL, EST		
	3 = EN, DE, FR, NL		

Note: All the ADAPT products with version letter designation b are of Version 5.

TUNE Temp

TUNE Temp is a wall-mounted set point selector for room temperature in applications where the user shall be able to enter settings.

- Set point change $\pm 3^{\circ}\text{C}$.
- Output signal: $5 \pm 5 \text{ V DC}$

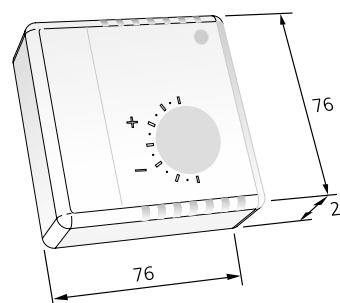

Figure 16. TUNE Temp

Electrical data

Supply voltage	24 V AC $\pm 10\%$
Power consumption	1 VA
Outputs: 0-10 V max load	10 mA
Degree of protection	IP 30

Ordering key

TUNE Temp set point selector	TUNE T	a
Version:		

LINK Modbus

RJ12 modular cable for wiring between master diffuser/damper and CONNECT Adapt for a main control system.

Ordering key

LINK Modbus RJ12 cable	LINK M	a	-aa
Version:			
Length: 2, 3, 5 or 10 m			



Figure 17. LINK Modbus

LINK Tuneadapt

The RJ12 modular cable for extending the outlet for TUNE Adapt, permits contact from room level with the ADAPT Damper installed high above the false ceiling.

Ordering key

LINK Tuneadapt RJ12 cord with outlet	LINK T	a	-aa
Version:			
Length: 6, 10 or 14 m			



Figure 18. LINK Tuneadapt

LINK Adapt

RJ45 modular cable for wiring between master diffuser/damper and CONNECT Adapt if lengths other than those which included in the supply are needed.

Ordering key

LINK Adapt RJ45 cable	LINK A	a	-aa
Version:			
Length: 2, 3, 5 or 10 m 5 m is standard and is always included in a delivery			

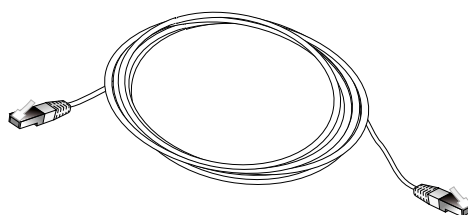

Figure 19. LINK Adapt.

SPLIT Link

Fork operation allowing more diffusers to be connected to a master/slav group by using LINK Adapt or LINK Modbus to connect from one diffuser to another.

Specifikation

SPLIT Link Fork operation	SPLIT L	a	-aaa aa
Type: SPLIT Adapt = LAa 45 SPLIT Modbus = LMa 12			



Figure 20. SPLIT Link.

FIX Link

Fix Link for fixing cords to ducts, for example. The holder is inserted into a 6 mm dia. drilled hole and is self-locking. The bundling strap locks the cords in place.

Ordering key

FIX Link cable attachment, 100 pack.	FIX L	a	
Version:			

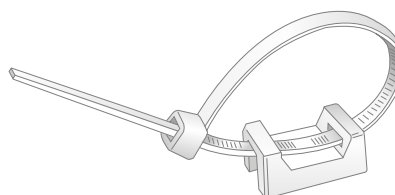

Figure 21. FIX Link.

POWER Adapt

Single phase protective transformer for main plug connection, unearthed or earthed. The transformer is made of impact-resistant, light grey, self-extinguishing thermoplastic. POWER Adapt manages to operate a normal office room with 2 pc ADAPT dampers and up to three radiator valves. Meets applicable requirements for electrical safety/emissions and immunity.

Technical data

Input voltage	230 V 50-60 Hz
Output voltage	24 V AC
Capacity	20 VA
Enclosure:	IP33

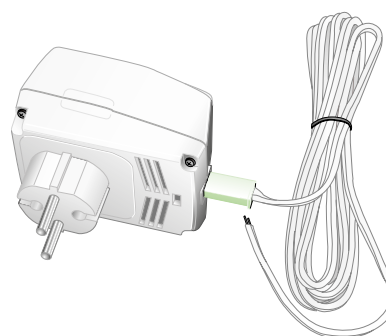

Figure 22. POWER Adapt.

Ordering key

Single-phase transformer	POWER A	a	-aaa
Version:			
Size: 20 VA, 60 VA, 150 VA			

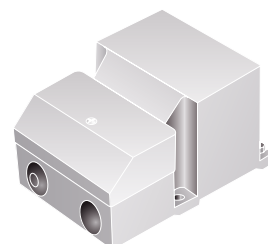

Figure 23. POWER Adapt 60/150 VA.

ADAPT Relay

Relay for on/off control of the lighting, designed for installation in a wall terminal box or the like. As an alternative, the relay can be supplied with a type CONNECT Adapt round enclosure conforming to degree of protection IP30.

Electrical data

Supply voltage	24 V ±2 V AC/DC
Power consumption	0,5 VA
Circuit-breaking capacity	10A/250 V AC
Incandescent and halogen lamps	2000 W
Fluorescent lamp load with KVG with lead-lag compensation or uncompensated	1000 VA
Fluorescent lamp load with KVG or shunt coupling or with EVG	500 VA
Compact fluorescent lamps with EVG and low energy lamps	I on < 70A/10ms*)

*) You must pay attention to the inrush current of electrical HF devices; an electric current monitor relay is recommended.

Ordering key

ADAPT Relay	ADAPT R	a	-a	-24/230 V AC
Version:				
Enclosed= C				
Not enclosed= N				
Control voltage/Recovery voltage				

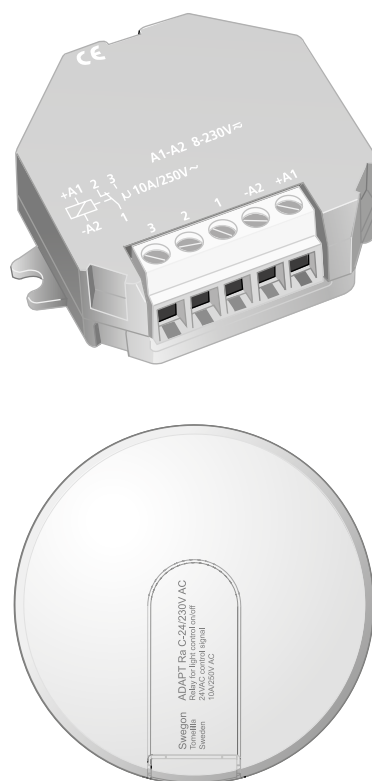

Figure 24. ADAPT Relay in non-enclosed version (N) and enclosed (C).

FSR clamp

Clamp made of galvanised sheet steel, used for facilitating installation and removal of damper units. The clamp has adjustable eccentric locking devices for simple and quick locking/opening. The rubber gasket allows sealing directly against duct nipple. Always fit the clamp on the “room side” of the damper.

Quick facts

- Thick rubber seal
- Adjustable eccentric locking devices

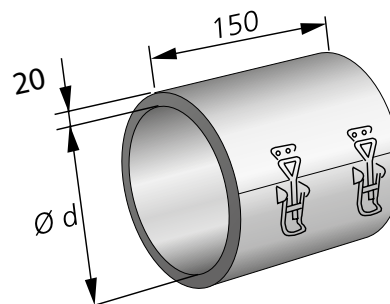

Figur 25. FSR, clamp.

Size	ØD (mm)	Weight (Kg)
125	124	0,7
160	159	0,9
200	199	1,1
250	249	1,3
315	314	1,5
400	399	1,9
500	499	2,2

Ordering key

Clamp	FSR	c	-aaa
Version:			
Size: 125, 160, 200, 250, 315, 400, 500			

ACTUATOR

Thermo-actuator, on/off in NC version with pin-connection cable ends. NC = Normally closed.

- Power supply: 24 V AC/DC, ±10%, 0-60 Hz
- Temperature: Operating temperature, room air: 0-60 °C
Operating temperature, energy carrier: 10-100 °C
- Cable: Fixed two-wire cable, L= 1.0 m, Ø 0.5 mm²
- Power consumption, start: 7 VA for a maximum of 2 min.
- Power consumption, operation: 2 VA
- Degree of protection: IP 41
- Connection: As standard, the VA-80 adapter is included, fits an M30 x 1.5 mm threaded socket.

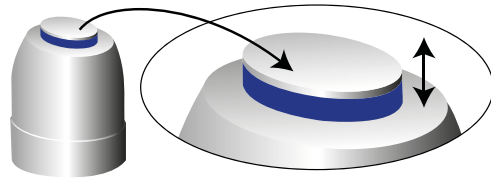

Figure 26. ACTUATOR damper blade position indicator. The actuator's cylinder shaped position indicator clearly shows, from all angles, which operating setting is current. When the indicator is at its lowest position and at the same height as the enclosure, the actuator is in closed position. When the indicator is in the raised position above the enclosure, the actuator is in the open position.

For alternative adapters contact Swegon.

"First open" function

The actuator is set to the "first open" function on delivery. This means that the actuator is open when it is installed making it easier to pressure test and vent the water system. The function will be automatically disabled after the actuator has been energized for approx. 6 minutes. A clicking noise will be heard after which the actuator will change over to the NC mode and the normal regulation function will begin.

Ordering key

Valve actuator ACTUATOR

VALVE

Radiator valve of angled or straight design. Dull nickel-plated bronze.

- Max. allowed operating pressure: 1000 kPa
- Max. allowed pressure drop: Across open valve: 20 kPa
Across closed valve: 150 kPa
- Min. allowed inlet flow temp.: 110 °C

Ordering key

Radiator valve VALVE a -a -bb
 Version:
 Straight version = S
 Angled version = A
 DN: 110, 115 or 120

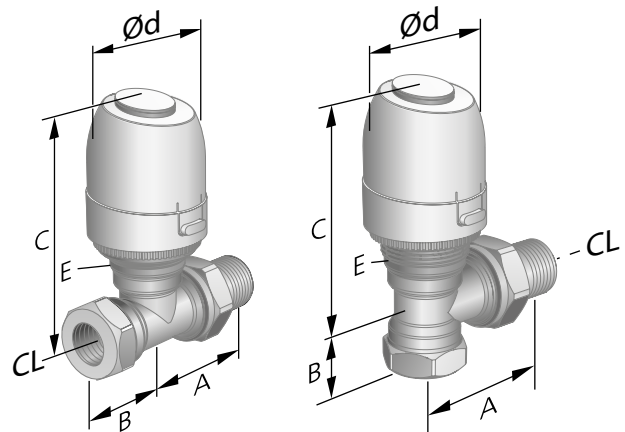

Figure 27. VALVE-S valve and VALVE-A respectively with ACTUATOR valve actuator mounted. E = M30 x 1.5 mm threaded mount

DN	Threads	Dimensions (mm)			k _v value
		A	B	C	
S 110	3/8"	59	26	81	0.09-0.63
S 115	1/2"	61	33	81	0.10-0.89
S 120	3/4"	63	35	81	0.31-1.41
A 110	3/8"	49	20	81	0.09-0.63
A 115	1/2"	53	23	81	0.10-0.89
A 120	3/4"	63	26	81	0.31-1.14