

## INSTALLATION INSTRUCTIONS

# SILVER<sup>M</sup> C, RX/PX/CX

---

---



- GB - Installation instructions
- SE - Installationsanvisning
- DE - Installationsanleitung
- FR - Instructions d'installation
- NO - Installasjonsanvisning
- DK - Installationsanvisning
- FI - Asennusohje
- PL - Instrukcja instalacji
- RU - Инструкция по установке и монтажу
- ES - Instrucciones de instalación
- IT - Istruzioni per l'installazione
- PT - Instruções de instalação
- NL - Installatieaanwijzing

# CONTENTS

The document was originally written in Swedish.

## GB - CONTENTS

1. Key to symbols	4-5
2. Lifting	6
3. Unpacking	7
4. Serial number	7
5. Moving into position	8
6. Placement	9-10
7. Water trap	11
8. Connection to the Ducting	12-13
9. Electrical Connections	14
10. Airflow direction	14

## NO - INNHOLDSFORTEGNELSE

1. Tegnforklaring	4-5
2. Løfte	6
3. Oppakning	7
4. Serienummer	7
5. Inntransport	8
6. Plassering	9-10
7. Vannlås	11
8. Tilkobling kanaler	12-13
9. El-tilkobling	14
10. Luftretning	14

## SE - INNEHÅLLSFÖRTECKNING

1. Teckenförklaring	4-5
2. Lyft	6
3. Uppackning	7
4. Serienummer	7
5. Intransport	8
6. Placering	9-10
7. Vattenlås	11
8. Anslutning kanaler	12-13
9. Elanslutning	14
10. Luftriktning	14

## DK - INHOLDSFORTEGNELSE

1. Tegnforklaring	4-5
2. Løfte	6
3. Udpakning	7
4. Serienummer	7
5. Transport ind i bygningen	8
6. Placering	9-10
7. Vandlås	11
8. Tilslutning, kanaler	12-13
9. El-tilslutning	14
10. Luftretning	14

## DE - INHALTSVERZEICHNIS

1. Zeichenerklärung	4-5
2. Anheben	6
3. Auspacken des Zubehörs	7
4. Seriennummer	7
5. Einfahren	8
6. Innenaufstellung	9-10
7. Siphon	11
8. Anschluss Kanäle	12-13
9. Elektroanschluss	14
10. Luftrichtung	14

## FI - SISÄLLYSLUETTELO

1. Merkkien selitys	4-5
2. Nostaminen	6
3. Pakkauksen purkaminen	7
4. Sarjanumero	7
5. Sisäänkuljetus	8
6. Sijoitus	9-10
7. Vesilukko	11
8. Kanavaliitäntä	12-13
9. Tehonsyöttöliitäntä	14
10. Ilmavirran	14

## FR - TABLE DE MATIÈRES

1. Explication des symboles	4-5
2. Levage	6
3. Déballage	7
4. Numéro de série	7
5. Démontage de l'unité	8
6. Positionnement	9-10
7. Siphon	11
8. Raccordement canaux	12-13
9. Raccordement électrique	14
10. Sens de circulation de l'air	14

## PL - SPIS TREŚCI

1. Oznaczenia symboli	4-5
2. Transport pionowy	6
3. Rozpakowanie-części składowe centrali	7
4. Numery seryjne	7
5. Transport wewnątrz pomieszczeń	8
6. Posadowienie centrali	9-10
7. Syfon wodny	11
8. Podłączenie przewodów powietrza	12-13
9. Włącznik główny	14
10. Zmiana kierunku przepływu powietrza	14

# CONTENTS

## RU - Оглавление

1. Обозначения .....	4-5
2. Подъем краном .....	6
3. Распаковывание .....	7
4. Серия-номер .....	7
5. Перемещение .....	8
6. Установка .....	9-10
7. Водяной затвор .....	11
8. Присоединение .....	12-13
9. Подключение питания .....	14
10. Изменение направления воздуха .....	14

## PT - ÍNDICE

1. Explicação de símbolos .....	4-5
2. Levantar .....	6
3. Desembalagem .....	7
4. Número de série .....	7
5. Transporte da unidade para dentro do edifício .....	8
6. Colocação .....	9-10
7. Sifão .....	11
8. Ligaçao canais .....	12-13
9. Ligaçao eléctrica .....	14
10. Direcção do ar .....	14

## ES - ÍNDICE

1. Explicación de los símbolos .....	4-5
2. Elevación .....	6
3. Desembalaje .....	7
4. Número de serie .....	7
5. Transporte interno .....	8
6. Ubicación .....	9-10
7. Colector de agua .....	11
8. Conductos de conexión .....	12-13
9. Conexión eléctrica .....	14
10. Dirección del aire .....	14

## NL - INHOUDSOPGAVE

1. Legenda .....	4-5
2. Het opheffen .....	6
3. Uitpakken .....	7
4. Serienummer .....	7
5. Transport in .....	8
6. Plaatsing .....	9-10
7. Sifon .....	11
8. Aansluiten kanalen .....	12-13
9. Aansluiten .....	14
10. Luchtrichting .....	14







## IT - INDICE

1. Legenda .....	4-5
2. Sollevamento .....	6
3. Disimballaggio .....	7
4. Numero di serie .....	7
5. Trasporto in entrata .....	8
6. Posizionamento .....	9-10
7. Sifone .....	11
8. Collegamento dei canali .....	12-13
9. Collegamenti elettrici .....	14
10. Direzione dell'aria .....	14

1.

EN	SE	DE	FR	NO
 <p>Warning</p>	Varning	Warnung	Avertissement	Advarsel
 <p>Protect from moisture</p>	Skyddas från väta	Vor Nässe schützen	Protéger contre l'humidité	Beskyttes fra væte
 <p>Outdoor air</p>	Uteluft	Außenluft	Air extérieur	Uteluft
 <p>Supply air</p>	Tilluft	Zuluft	Air de pulsion	Tilluft
 <p>Extract air</p>	Frånluft	Abluft	Air extrait	Avtrekksluft
 <p>Exhaust air</p>	Avluft	Fortluft	Air rejeté	Avkast

DK	FI	PL	RU	ES
 <p>Advarsel</p>	Varoitus	Uwaga!	Внимание	Advertencia
 <p>Beskyttes mod væde</p>	Suojattava kastumiselta	Chronić przed wilgocią	Защитить от влаги	Proteger contra la humedad
 <p>Friskluft</p>	Ulkoilma	Powietrze zewnętrzne	Наружный воздух	Aire exterior
 <p>Indblæsningsluft</p>	Tuloilma	Powietrze nawiewane	Приточный воздух	Aire de impulsión
 <p>Udsugningsluft</p>	Poistoilma	Powietrze wywiewane	Отработанный воздух	Aire de retorno
 <p>Afgangsluft</p>	Jäteilma	Powietrze wyrzucane	Вытяжной воздух	Aire de extracción

IT	PT	NL		
 <p data-bbox="229 215 336 237">Avvertenza</p>	<p data-bbox="491 215 544 237">Aviso</p>	<p data-bbox="754 215 884 237">Waarschuwing</p>		
 <p data-bbox="229 327 363 349">Teme l'umidità</p>	<p data-bbox="491 327 635 371">Proteger contra a humidade</p>	<p data-bbox="754 327 858 371">Tegen vocht beschermen</p>		
 <p data-bbox="229 450 336 472">Aria esterna</p>	<p data-bbox="491 450 592 472">Ar exterior</p>	<p data-bbox="754 450 855 472">Buitenlucht</p>		
 <p data-bbox="229 573 363 595">Aria in entrata</p>	<p data-bbox="491 573 619 595">Ar de entrada</p>	<p data-bbox="754 573 847 595">Inlaatlucht</p>		
 <p data-bbox="229 696 347 719">Aria in uscita</p>	<p data-bbox="491 696 596 719">Ar de saída</p>	<p data-bbox="754 696 855 719">Uitlaatlucht</p>		
 <p data-bbox="229 819 288 842">Sfiato</p>	<p data-bbox="491 819 635 842">Ar de extracção</p>	<p data-bbox="754 819 855 842">Afvoerlucht</p>		

2.

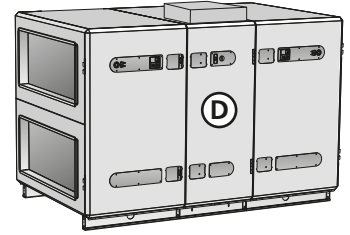
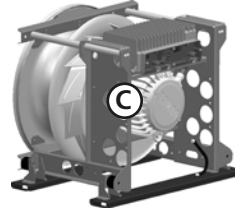
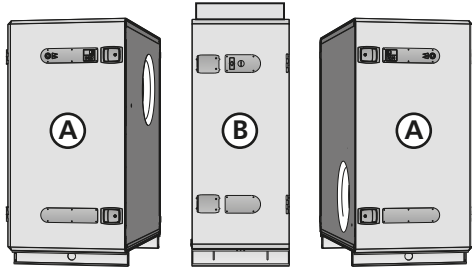

SILVER C RX	A (kg)	B (kg)	C (kg)	D (kg)
04/05	-	-	20	243
04/05 Top	-	-	19	247
07	-	-	21	301
07 Top	-	-	21	306
08	-	-	25	309
08 Top	-	-	23	310
11	167	162	28	496
11 Top	163	162	28	488
12	178	162	39	518
12 Top	171	162	36	504
14	209	171	40	589
20	227	171	65	625
25	265	216	65	746
30	285	216	78	786
35	379	312	78	1070
40	404	312	103	1120
50	502	414	65	1418
60	542	414	78	1498
70	816	579	78	2211
80	928	579	134	2435

SILVER C PX	A (kg)	B (kg)	C (kg)	D (kg)
04/05	-	-	20	337
07	-	-	21	419
08	-	-	25	428
11	167	312	28	646
12	178	312	39	668
14	209	355	40	773
20	227	355	65	809
25	265	528	65	1058
30	285	528	78	1098

SILVER C CX	A (kg)	B (kg)	C (kg)	D (kg)
35	379	766	78	1524
40	404	766	103	1574
50	502	1007	65	2011
60	542	1007	78	2091
70	816	1317	78	2949
80	928	1317	134	3173

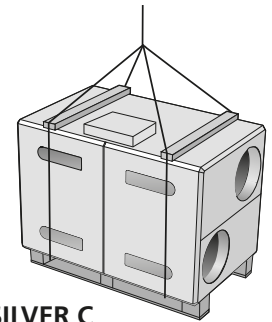

SILVER C  
RX 04/05, 08

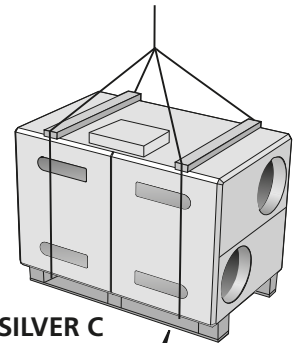

SILVER C  
PX 04/05,  
07/08

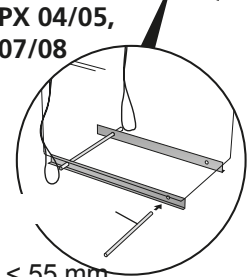

Ø < 55 mm

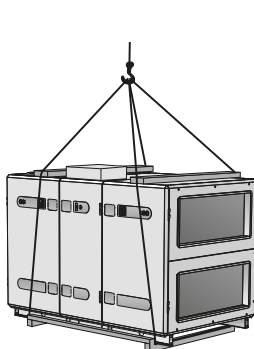

SILVER C  
RX 12, 14/20,  
25/30, 35/40  
PX 11/12, 14/20

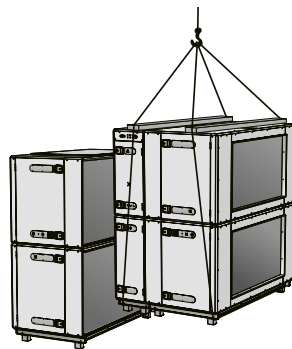

SILVER C  
PX 25/30  
CX 35/40



SILVER C  
RX 50/60

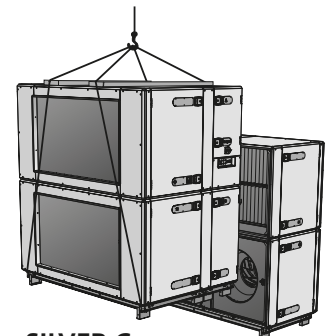

SILVER C  
RX 70/80  
CX 50/60  
CX 70/80

3.

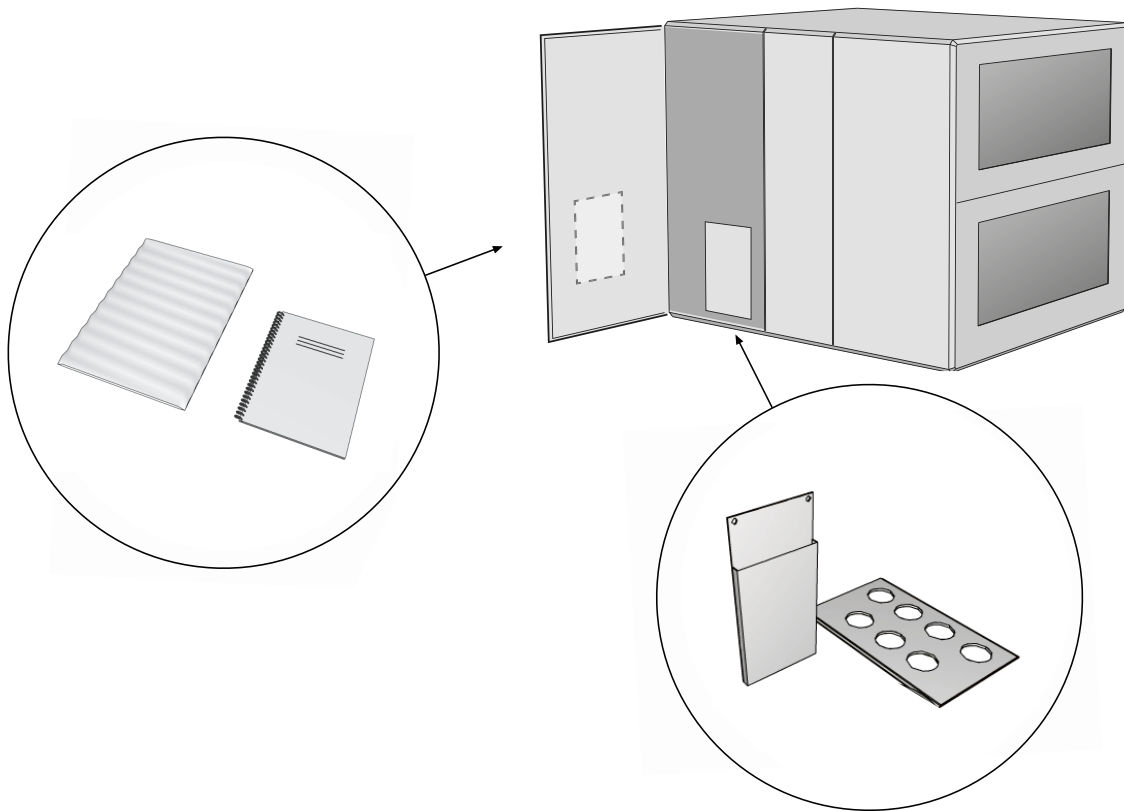

4.

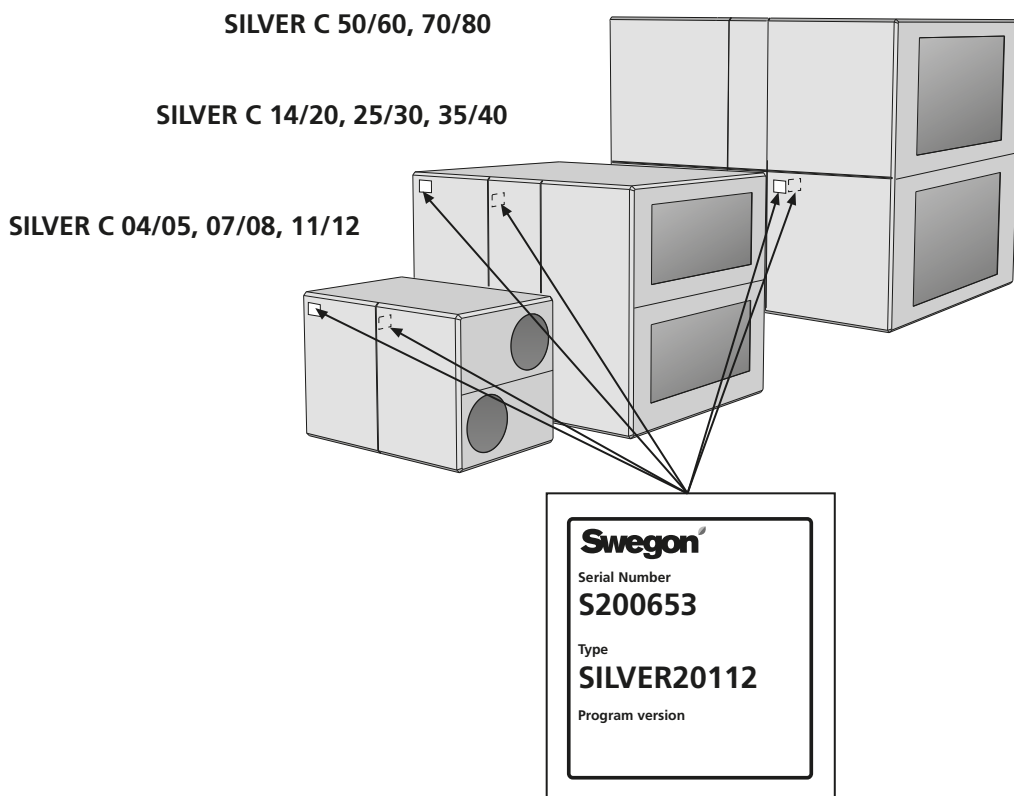

SILVER C 11/12, 14/20, 25/30, 35/40, 50/60 ○ ○  
SILVER C 70/80 ○ ☆

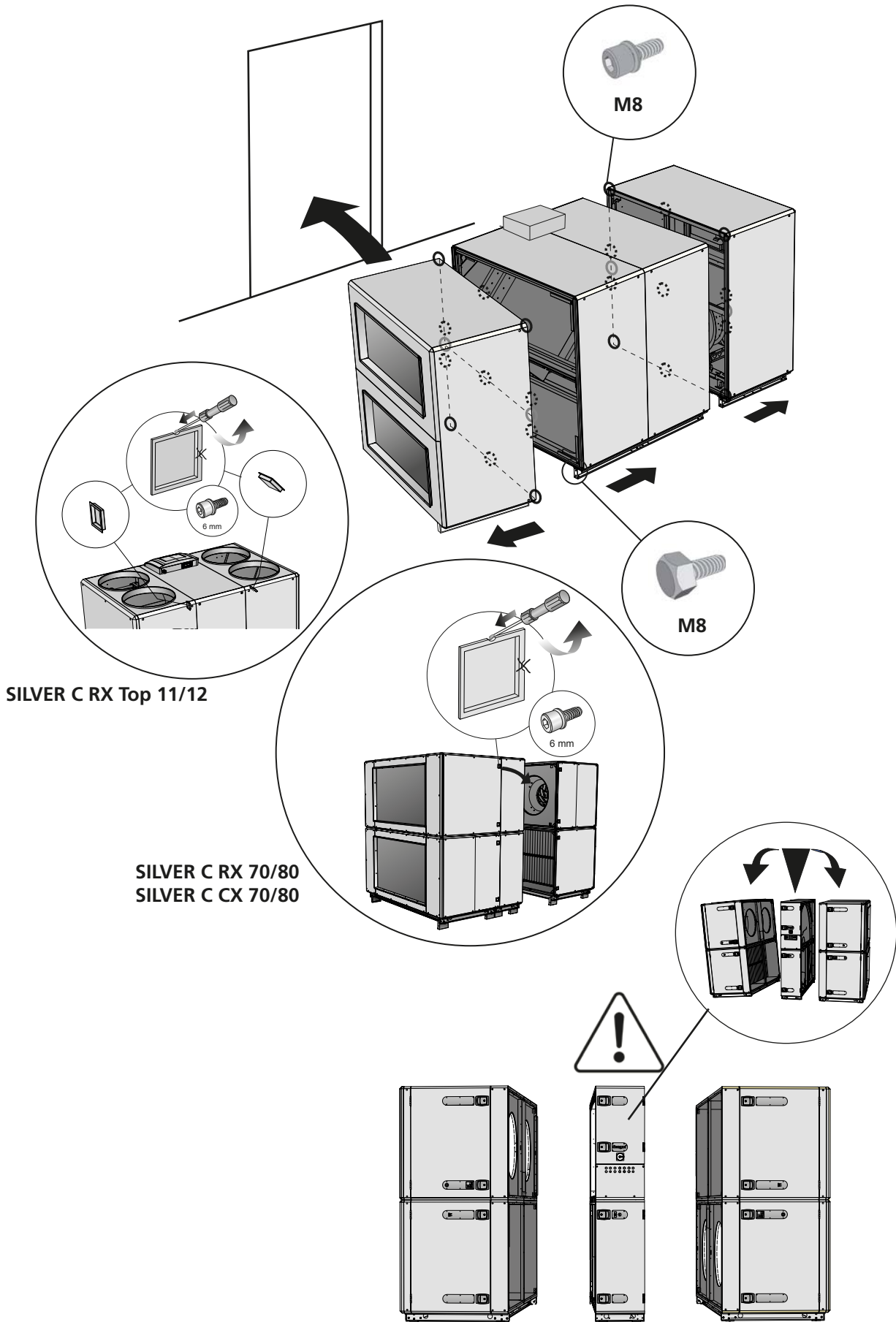



**SILVER C RX 04/05, 07/08**

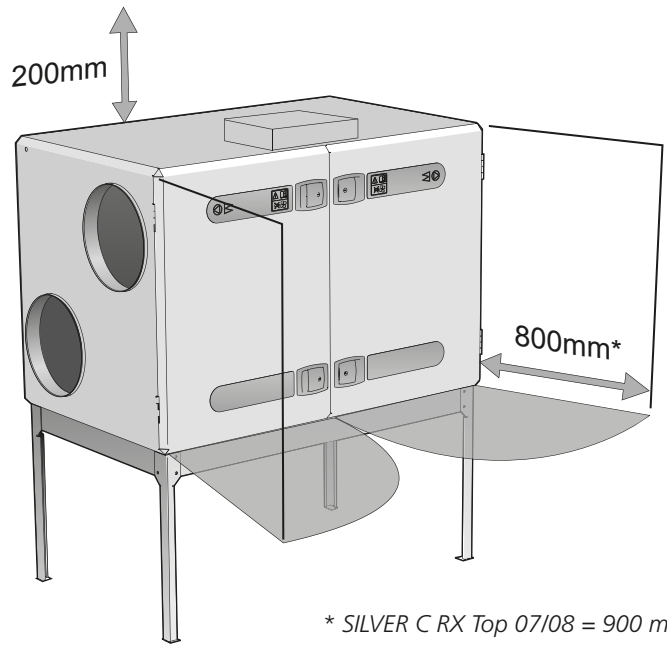
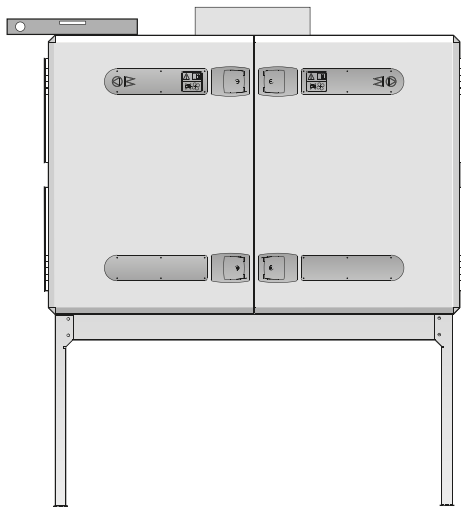

\* SILVER C RX Top 07/08 = 900 mm

**SILVER C PX 04/05, 07/08**

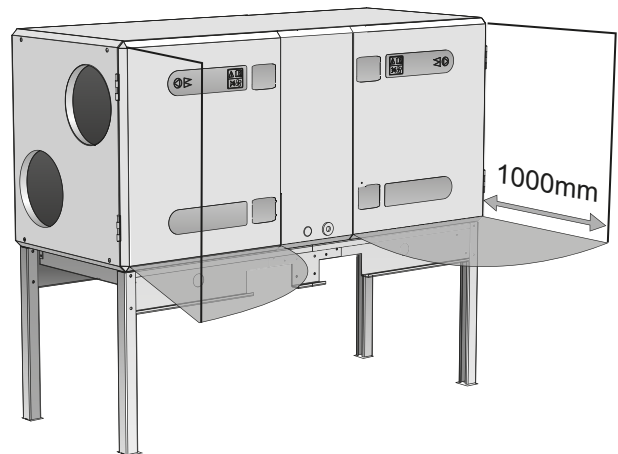
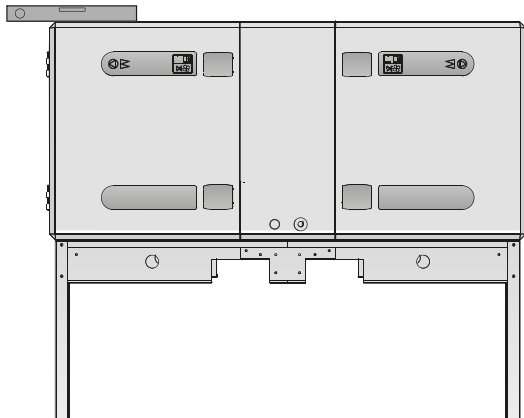

**SILVER C 11/12, 14/20, 25/30**

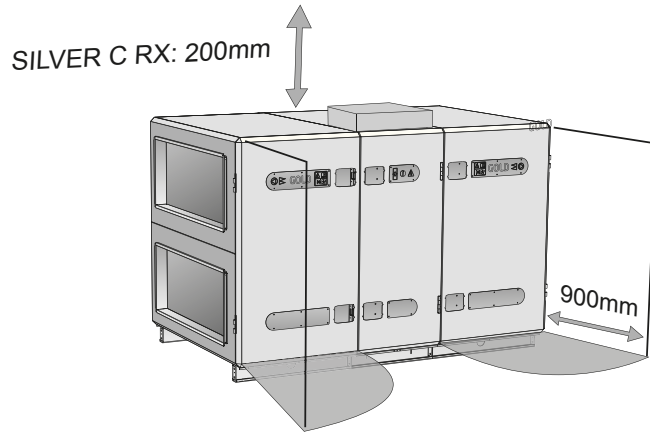
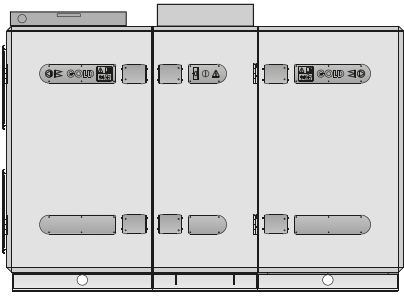

**SILVER C 35/40**

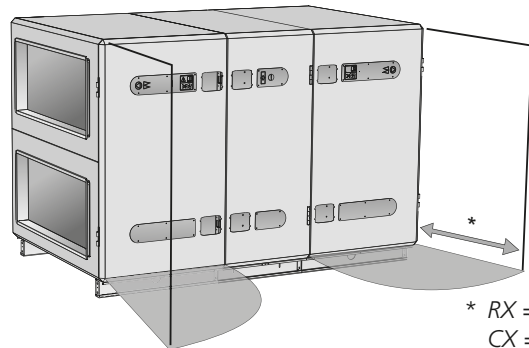
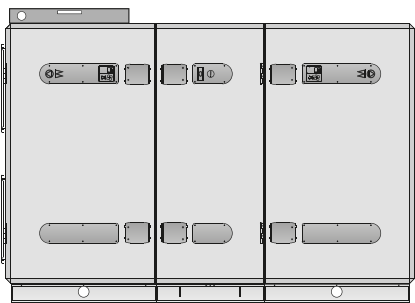

\* RX = 900 mm  
CX = 1000 mm

**SILVER C 50/60**

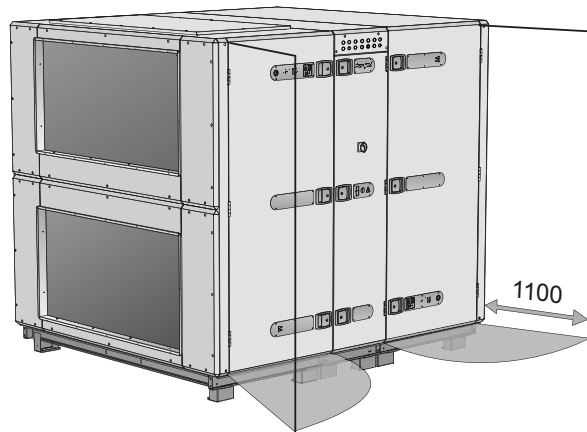
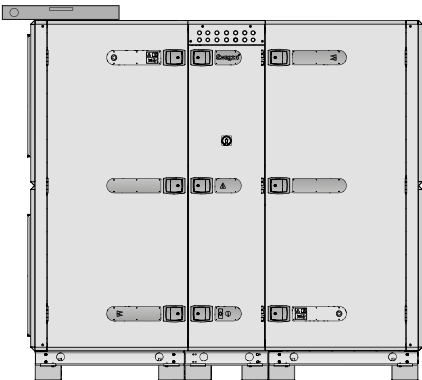

**SILVER C 70/80**

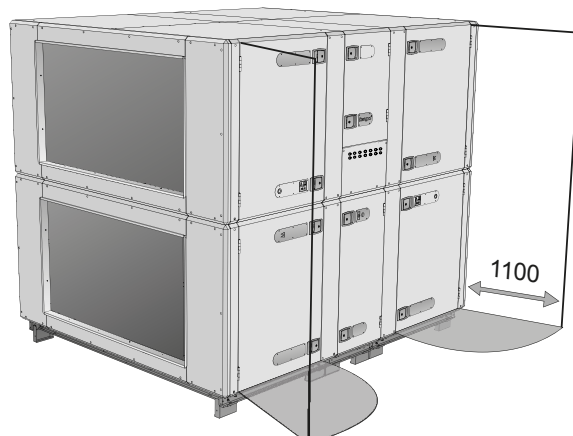
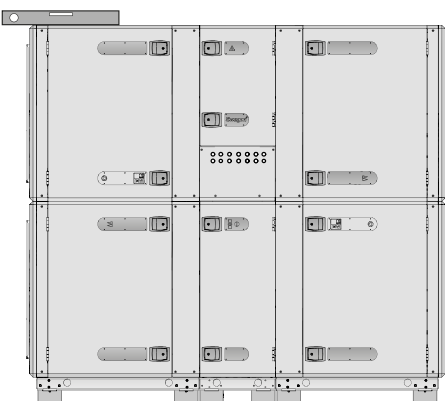

## SILVER C PX/CX

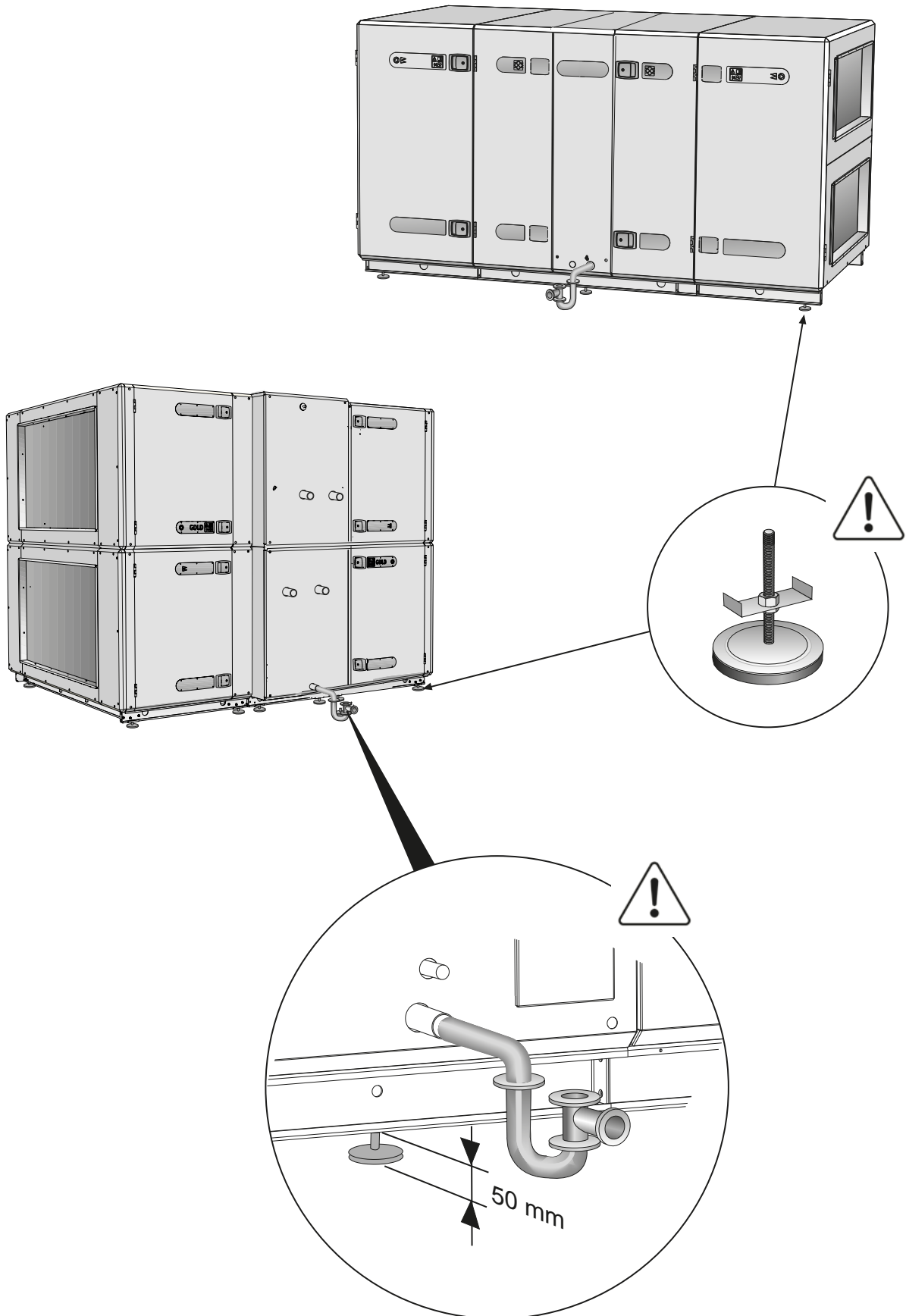

SILVER C 04/05, 07/08, 11/12

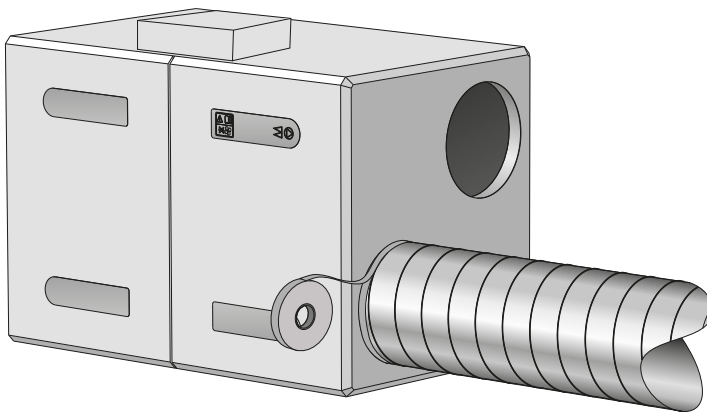
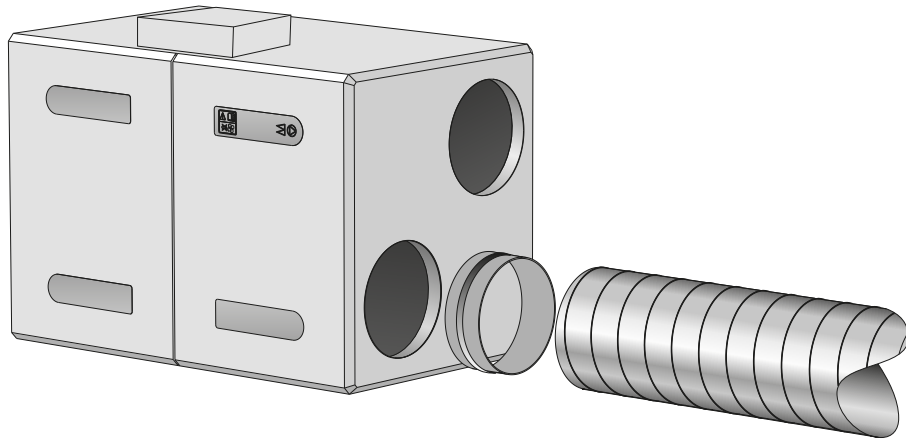

SILVER C 14/20, 25/30

SILVER C 35/40, 50/60, 70/80

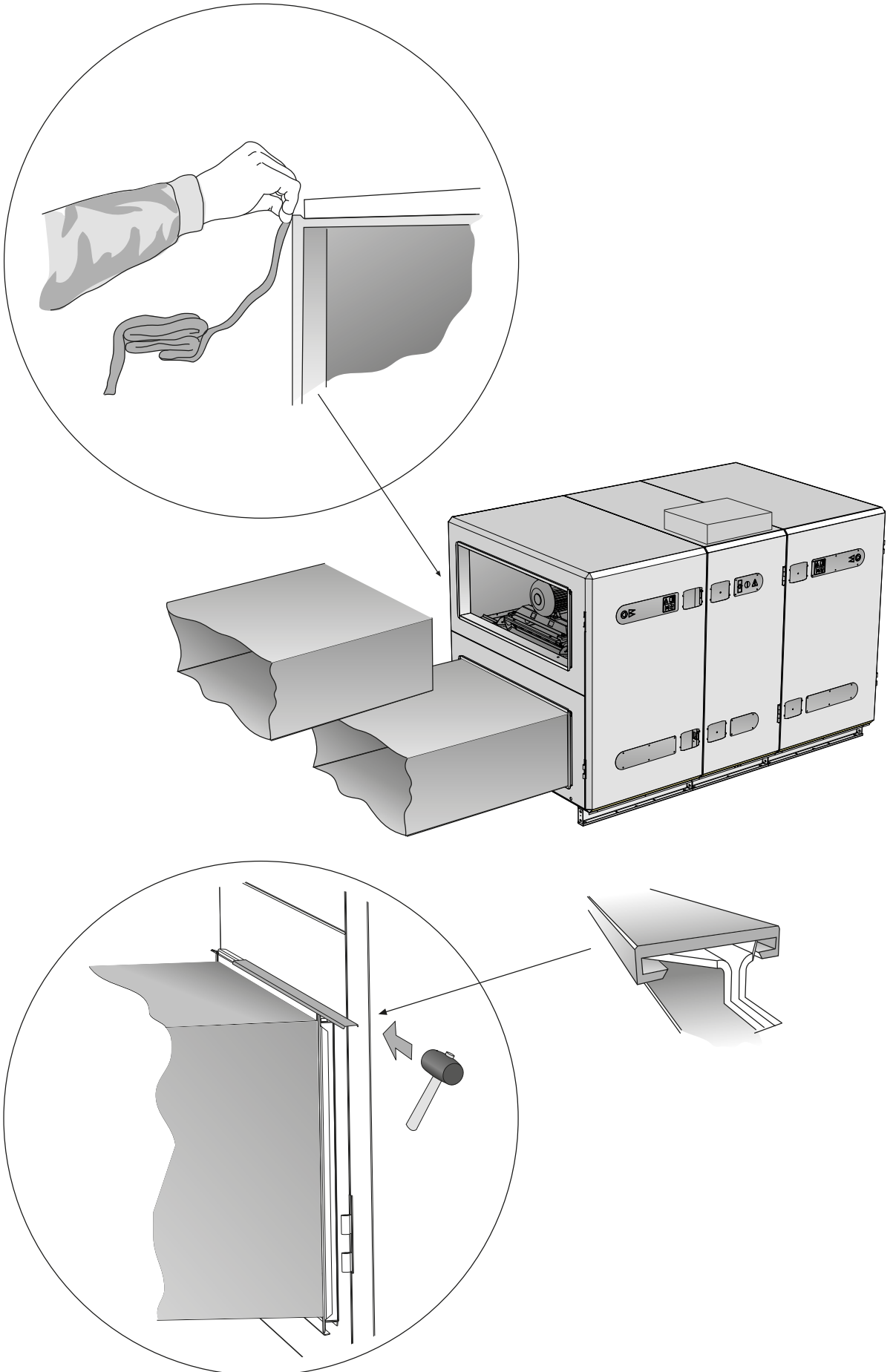

9.

GB - See special instructions for electrical connection of fan motors, heat exchanger controls, damper actuators etc.  
SE - Se särskilda instruktioner för elektrisk anslutning av fläktmotorer, värmväxlarstyrning, spjällmotorer etc.  
DK - Se separat vejledning til elektrisk tilslutning af ventilatormotorer, varmevekslerstyring, spjældmotorer osv.  
FI - Katso puhallinmoottorien, lämmösiirrinohjaimen, peltitoimilaitteiden jne. sähköliitännöjen erilliset ohjeet.

10.

**SILVER C RX 04/05, 08, 12**  
**SILVER C RX 14/20, 25/30, 35/40, 50/60, 70/80**

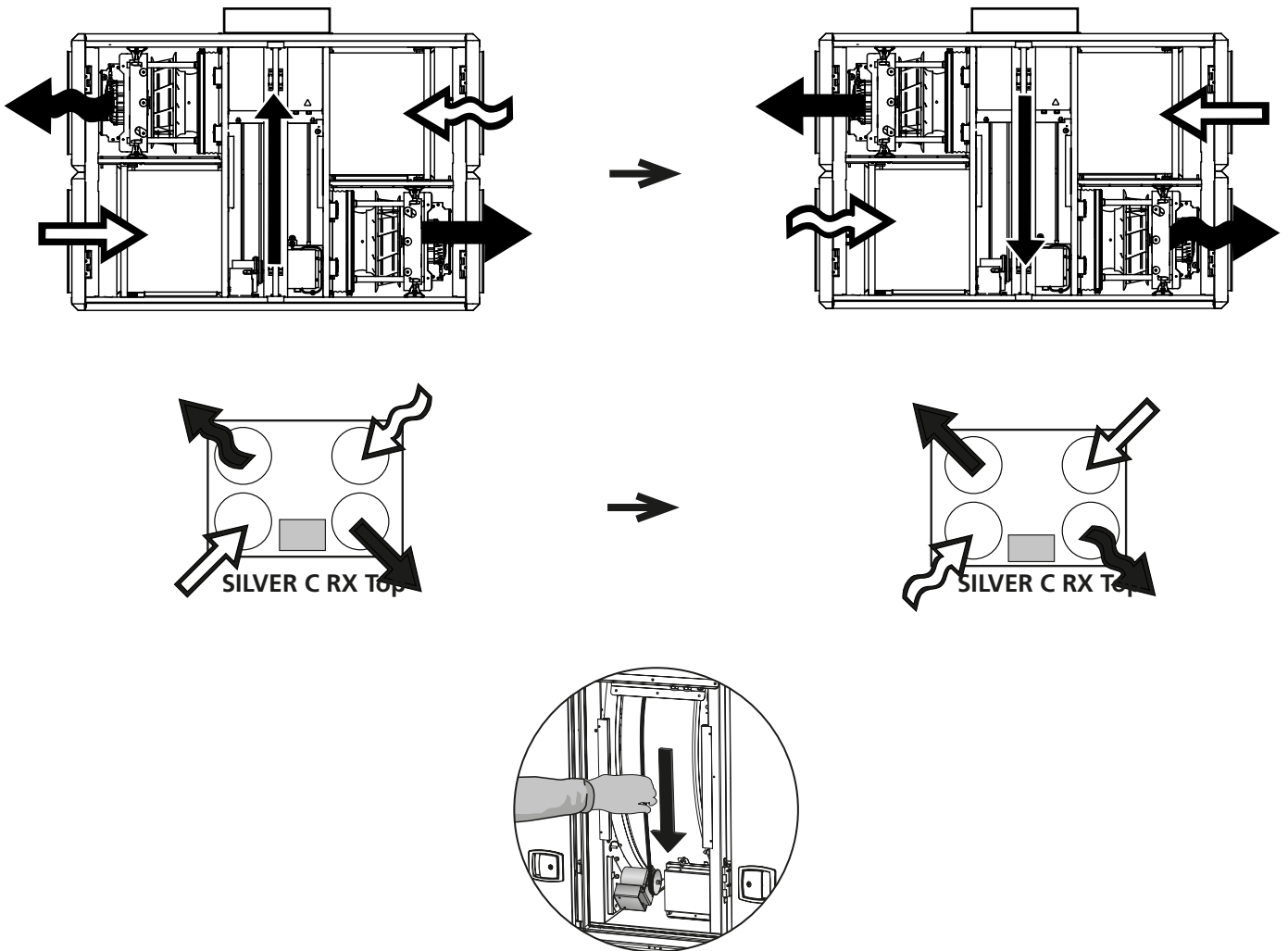

GB - See also special instructions for heat exchanger controls.  
SE - Se också särskild instruktion för värmväxlarstyrning.  
DK - Se også separat vejledning til varmevekslerstyring.  
FI - Katso myös erityisiä ohjeita lämmönvaihtimen ohjaukselle.



Specifications are subject to alteration without notice.