

METASYS N2 open GOLD RX/PX/CX/SD, GENERATION C/D

Applicable to program version 1.05 and newer versions

Metasys N2 open

Metasys nodes contains up to 256 Virtual Objects. These virtual objects can be either one of seven region types; 1) Analog Input, 2) Binary Input, 3) Analog Output, 4) Binary Output, 5) Internal Float, 6) Internal Integer and 7) Internal Byte. The Metasys N2 Master performs read and write commands to these Virtual Objects and performs cyclic polling of all the virtual objects as well.

Metasys N2 open Virtual Objects

A virtual object contains data of a specific type. These types are called Regions. A Metasys N2 node may contain up to 256 Virtual Objects per region, which in all gives a total of 1792 virtual objects. In smaller systems it might be desirable to limit the number of virtual objects to reduce memory consumption. The regions are defined as followed.

Region	Type	Short	Description
Region 1	Analog Input	AI	32 bit, IEEE-standard floats.
Region 2	Binary Input	BI	1 bit
Region 3	Analog Output	AO	32 bit, IEEE-standard floats.
Region 4	Binary Output	BO	1 bit
Region 5	Internal Float	IF	32 bit, IEEE-standard floats.
Region 6	Internal Integer	ADI	Signed 16 bit.
Region 7	Internal Byte	IB	8 bit.

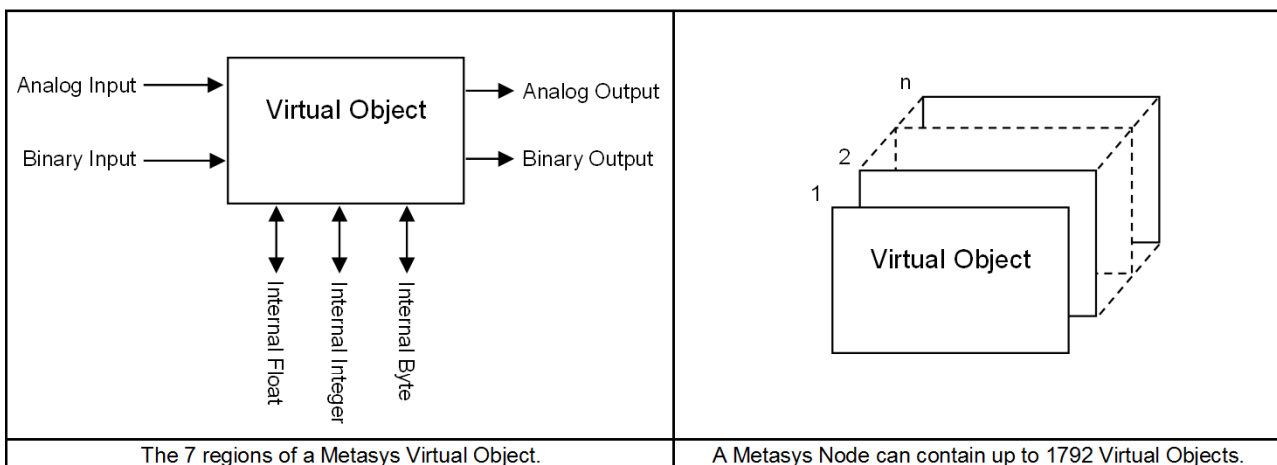

The 7 regions of a Metasys Virtual Object.

A Metasys Node can contain up to 1792 Virtual Objects.

Operation mode 1	ADI,110
Communication operation mode	ADI,95
Operation mode 2	ADI,111
Operation output	BI,8
Low speed output	BI,4
High speed output	BI,5
Damper output	BI,9
Present tripped alarm	ADI,101
A-alarm	BI,6
B-alarm	BI,7
Alarm reset	BO,1

EA Airflow	AI,3
EA Fan level	AI,14
EA Low speed airflow setpoint	AO,5
EA High speed airflow setpoint	AO,6

Outdoor temperature	AI,30
---------------------	-------

Supply air filter pressure level	AI,50
SA filter pressure level limit	AI,51

Heat exchange regulator	AI,57
-------------------------	-------

SA Airflow	AI,1
SA Fan level	AI,13
SA Low speed airflow setpoint	AO,1
SA High speed airflow setpoint	AO,2

Extract air filter pressure level	AI,53
EA filter pressure level limit	AI,54

EA Duct pressure	AI,7
EA Low speed pressure setpoint	AO,13
EA High speed pressure setpoint	AO,14

EA/Room temperature	AI,29
EA/Room temperature setpoint	AO,42
SA Min temperature setpoint	AO,43
SA Max temperature setpoint	AO,44

SA Duct Pressure	AI,5
SA Low speed pressure setpoint	AO,9
SA High speed pressure setpoint	AO,10

SA Temperature	AI,28
SA Temperature setpoint	AO,41
ERS 1 Diff	AO,33

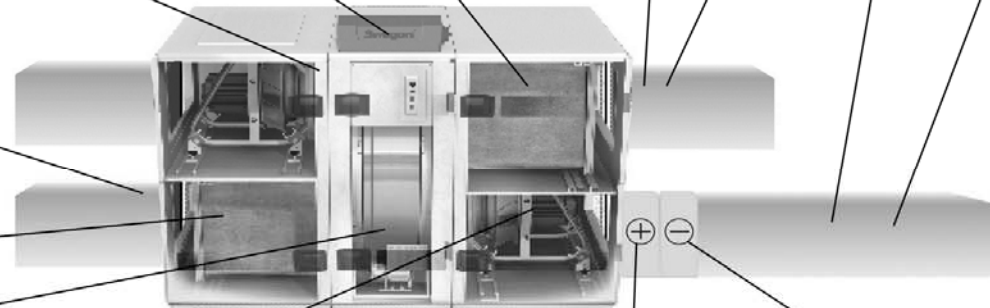

Reheat level	AI,37
Heat output	BI,1
Anti frost temperature	AI,33

Cooling level	AI,40
Cool output 1	BI,2
Cool output 2	BI,3

Analog Input (AI).32 bit IEEE-standard floats (RO).

N2 Idx	Name	Min/Max	Misc
1	SA Airflow Present supply airflow.	0-20000l/s	
2	SA Airflow regulator Present supply airflow regulator setpoint.	0-20000l/s	
3	EA Airflow Present extract airflow.	0-20000l/s	
4	EA Airflow regulator Present extract airflow regulator setpoint.	0-20000l/s	
5	SA Duct pressure Present supply air duct pressure.	0-2000Pa	
6	SA Duct pressure regulator Present supply air duct pressure regulator setpoint.	0-2000Pa	
7	EA Duct pressure Present extract air duct pressure.	0-2000Pa	
8	EA Duct pressure regulator Present extract air duct pressure regulator setpoint.	0-2000Pa	
9	SA VAV demand/boost input Present input signal for supply air VAV demand or boosting function.	0-100.00%	
10	SA VAV demand regulator Present supply air VAV demand regulator setpoint.	0-100.00%	
11	EA VAV demand/boost input Present input signal for extract air VAV demand or boosting function.	0-100.00%	
12	EA VAV demand regulator Present supply air VAV demand regulator setpoint.	0-100.00%	
13	SA Fan level Present running level for the supply air fan.	0-100.00%	
14	EA Fan level Present running level for the extract air fan.	0-100.00%	
15	SA Fan effect Present power consumption level for the supply air fan.	0-6500W	
16	EA Fan effect Present power consumption level for the extract air fan.	0-6500W	
17	SFP SFP supply air + extract air.	0.0-9.9	
18	SA Frequency Present frequency level for the supply air fan.	0-100.00Hz	
19	EA Frequency Present frequency level for the extract air fan.	0-100.00Hz	
20	SA Voltage Present voltage level for the supply air fan.	0-500V	
21	EA Voltage Present voltage level for the extract air fan.	0-500V	
22	SA Current Present current level for the supply air fan.	0-30.000A	
23	EA Current Present current level for the extract air fan.	0-30.000A	
24	SA Airflow pressure Present airflow pressure in the supply air fan inlet.	0-2000Pa	

Analog Input (AI).32 bit IEEE-standard floats (RO).

N2 Idx	Name	Min/Max	Misc
25	EA Airflow pressure Present airflow pressure in the extract air fan inlet.	0-2000Pa	
26	SA Temp regulator Present supply air temperature regulator setpoint.	-55.00-125.00°C	
27	EA Temp regulator Present extract air temperature regulator setpoint.	-55.00-125.00°C	
28	SA Temperature Present supply air temperature.	-55.00-125.00°C	
29	EA/Room temperature Present extract air/room temperature in the unit.	-55.00-125.00°C	
30	Outdoor temperature Present outdoor air temperature in the unit.	-55.00-125.00°C	
31	EA/Room temperature (external) Present room temperature external from the unit.	-55.00-125.00°C	
32	Outdoor temperature (external) Present outdoor air temperature external from the unit.	-55.00-125.00°C	
33	Anti frost temperature Present anti frost temperature for water reheating coils.	-55.00-125.00°C	
34	Temperature sensor 3 Present temperature for temp sensor no.3	-55.00-125.00°C	
35	Temperature sensor 4 Present temperature for temp sensor no.4	-55.00-125.00°C	
36	Rotary heat exchanger level Present operation level from rotary heat exchanger.	0-100.00%	
37	Reheat level Present level of reheat.	0-100.00%	
38	SA Down regulation level Present level of supply airflow down regulation.	0-100.00%	
39	Extra regulation sequence level Present level of the extra regulation sequence.	0-100.00%	
40	Cooling level Present level of cooling.	0-100.00%	
41	Heating boost level Present level of heating boost.	0-100.00%	
42	Cooling boost level Present level of cooling boost.	0-100.00%	
43	HX pressure level Present pressure drop for the rotary heat exchanger.	0-2000Pa	
44	HX pressure alarm limit Present pressure drop alarm limit for the rotary heat exchanger.	0-2000Pa	
45	HX temperature Present temperature inside the control unit for the rotary heat exchanger.	0-100.00°C	
46	Effect reduction level Present level of max output signal for electrical reheaters, active during low supply airflow.	0-100.00%	
47	Anti frost temp setpoint/operation Present anti frost temperature setpoint for water reheating coils during unit operation.	10.00-16.00°C	

Analog Input (AI).32 bit IEEE-standard floats (RO).

N2 Idx	Name	Min/Max	Misc
48	Anti frost temp setpoint/stop Present anti frost temperature setpoint for water reheating coils when the unit is in stop.	15.00-40.00°C	
49	Anti frost temp alarm limit Setting of antifrost temperature alarm limit.	5.00-30.00°C	
50	Supply air filter pressure level Present supply air filter pressure drop.	0-2000Pa	
51	Supply air filter pressure alarm limit. Present supply air filter pressure alarm limit.	0-2000Pa	
52	Supply air filter pressure level, new Supply air filter pressure saved from calibration.	0-2000Pa	
53	Extract air filter pressure level Present extract air filter pressure drop.	0-2000Pa	
54	Extract air filter pressure alarm limit. Present extract air filter pressure alarm limit.	0-2000Pa	
55	Extract air filter pressure level, new Extract air filter pressure saved from calibration.	0-2000Pa	
56	Temperature displacement Present temperature displacement from input signal.	-5.00 - 5.00°C	
57	Heat exchange regulator Present level of heat exchange regulator RX/CX/PX.	0-100.00%	
58	Extract air-humidity Present level of extract air-humidity.	0-100.00%	
59	Extract air-humidity temperature Present temperature inside extract air-humidity sensor.	-55.00-125.00°C	
60	Extract air-dewpoint Calculated extract air-dewpoint.	-55.00-125.00°C	
61	AYC chilled water temperature Present AYC chilled water temperature.	-55.00-125.00°C	
62	AYC chilled water temperature regulator Present AYC chilled water temperature regulator setpoint.	-55.00-125.00°C	
63	AYC chilled water output Present level of AYC chilled water valve output.	0-100.00%	
64	Supply air-dewpoint regulator Present supply air-dewpoint regulator setpoint.	-55.00-125.00°C	
65	Supply air-humidity Present level of supply air-humidity	0-100.00%	
66	Supply air-humidity temperature Present temperature inside supply air-humidity sensor.	-55.00-125.00°C	
67	Supply air-dewpoint Calculated supply air-dewpoint.	-55.00-125.00°C	
68	C.HX. Temperature Present temperature of coil heat exchanger.	-55.00-125.00°C	PV 2.00
69	P.HX. Temperature 1 Present temperature 1 of plate heat exchanger.	-55.00-125.00°C	PV 2.00
70	P.HX. Temperature 2 Present temperature 2 of plate heat exchanger.	-55.00-125.00°C	PV 2.00
71	P/C.HX. Humidity Present level of air-humidity in plate/coil heat exchanger.	0-100.00%	PV 2.00
72	R.HX. Efficiency	0-100.00%	PV 2.00

Analog Input (AI).32 bit IEEE-standard floats (RO).

N2 Idx	Name	Min/Max	Misc
	Calculated level of rotary heat exchanger efficiency.		
73	C.HX. Valve output	0-100.00%	PV 5.00
	Present level of coil heat exchanger valve output.		
74	P.HX bypass output	0-100%	PV 5.00
	Present level of plate heat exchanger bypass output.		
75	Supply air pre-filter pressure level	50-300Pa	PV 5.00
	Present supply air pre-filter pressure drop.		
76	Supply air pre-filter pressure alarm limit.	50-300Pa	PV 5.00
	Present supply air pre-filter pressure alarm limit.		
77	Supply air pre-filter pressure level, new	50-300Pa	PV 5.00
	Supply air pre-filter pressure saved from calibration.		
78	Extract air pre-filter pressure level	50-300Pa	PV 5.00
	Present extract air pre-filter pressure drop.		
79	Extract air pre-filter pressure alarm limit.	50-300Pa	PV 5.00
	Present extract air pre-filter pressure alarm limit.		
80	Extract air pre-filter pressure level, new	50-300Pa	PV 5.00
	Extract air pre-filter pressure saved from calibration.		
81	Xzone reheat level	0-100.00%	PV 5.00
	Present level of Xzone reheat.		
82	Xzone anti frost temperature	0-40.00°C	PV 5.00
	Present Xzone anti frost temperature for water reheating coils.		
83	Xzone cooling level	0-100.00%	PV 5.00
	Present level of Xzone cooling.		
84	Xzone SA Temp regulator	5.00-40.00°C	PV 5.00
	Present Xzone supply air temperature regulator setpoint.		
85	Xzone EA Temp regulator	5.00-40.00°C	PV 5.00
	Present Xzone extract air temperature regulator setpoint.		
86	Xzone SA Temperature	5.00-40.00°C	PV 5.00
	Present Xzone supply air temperature.		
87	Xzone EA/Room temperature	5.00-40.00°C	PV 5.00
	Present Xzone extract air/room temperature.		
88	Pre-heating air temperature	5.00-40.00°C	PV 5.00
	Present pre-heating air temperature.		
89	Pre-heating level	0-100.00%	PV 5.00
	Present level of pre-heating.		
90	Pre-heating anti frost temperature	0-40.00°C	PV 5.00
	Present anti frost temperature for water pre-heating coils.		
91	ReCO2 CO2 input	0-100.00%	PV 5.00
	Present input signal for ReCO2 CO2.		
92	ReCO2 internal damper output	0-100.00%	PV 5.00
	Present output signal for ReCO2 internal damper.		
93	ReCO2 external damper output	0-100.00%	PV 5.00
	Present output signal for ReCO2 external damper.		
94	ReCO2 outdoor airflow	0-20000l/s	PV 5.00
	Present ReCO2 outdoor airflow.		
95	ReCO2 outdoor airflow regulator	0-20000l/s	PV 5.00
	Present ReCO2 outdoor airflow regulator setpoint.		
96	ReCO2 outdoor airflow pressure	0-2000Pa	PV 5.00
	Present ReCO2 outdoor airflow pressure.		

Analog Input (AI).32 bit IEEE-standard floats (RO).

N2 Idx	Name	Min/Max	Misc
97	Supply air-D temperature	-55.00-125.00°C	PV 5.07
	Present supply air-D temperature.		
98	Extract air-D temperature	-55.00-125.00°C	PV 5.07
	Present extract air-D temperature.		
99	AYC heat temperature	-55.00-125.00°C	PV 5.07
	Present AYC heat temperature.		
100	AYC heat temp regulator	-55.00-125.00°C	PV 5.07
	Present AYC heat temperature regulator setpoint.		
101	AYC heat valve output	0-100.00%	PV 5.07
	Present level of AYC heat valve output.		
102	Min/Max/Average Sens1Temp	-55.00-125.00°C	PV 5.15
	Present Min/Max/Average sensor 1 temperature.		
103	Min/Max/Average Sens2Temp	-55.00-125.00°C	PV 5.15
	Present Min/Max/Average sensor 2 temperature.		
104	Min/Max/Average Sens3Temp	-55.00-125.00°C	PV 5.15
	Present Min/Max/Average sensor 3 temperature.		
105	Min/Max/Average Sens4Temp	-55.00-125.00°C	PV 5.15
	Present Min/Max/Average sensor 4 temperature.		

Internal Integer (ADI).Signed 16bit.

N2 Idx	Name	Min/Max	R/W	Misc
1	SA Fan regulation mode	0 - 3	R/W	
	Setting of regulation type for the supply air fan. 0=Airflow reg. 1=Pressure reg. 2=Demand reg. 3=Slave controlled by EA fan.			
2	EA Fan regulation mode	0 - 3	R/W	
	Setting of regulation type for the extract air fan. 0=Airflow reg. 1=Pressure reg. 2=Demand reg. 3=Slave controlled by SA fan.			
3	ERS Step	1 - 4	R/W	
	Setting of curve when temperature is above breakpoint.			
4	Temperature regulation mode.	0 - 3	R/W	
	Setting of temperature regulation type. 0=ERS 1 reg. 1=ERS 2 reg. 2=SA reg. 3=EA/Room reg.			
5	Cooling off period	60 - 900s	R/W	
	Time setting for cooling off electrical heating coil.			
6	Coil type	0-20	R	
	Present connected reheat coil type.			
7	Cool step time	0 - 600s	R/W	
	Time setting between cool step shift.			
8	Cool step time	0-600s	R	
	Present time between cool step shift.			
9	Cool restart time	60 - 900s	R/W	
	Setting of time between two starts of the cool relays.			
10	Cool relay 1 restart time	0-900s	R	
	Present time between two starts of cool relay 1.			
11	Cool relay 2 restart time	0-900s	R	
	Present time between two starts of cool relay 2.			
12	Cool regulation mode	0 - 6	R/W	PV 3.00
	Setting of cool regulation type 0=Controlled 0-10V 1=Controlled 10-0V 2=On/Off 1-step 3=On/Off 2-steps 4=On/Off 3-steps binary 5=CoolDX economy (PV 2.00) 6=CoolDX comfort (PV 3.00)			
13	Heating boost regulation mode.	0 - 1	R/W	
	Setting for heating boost function. 0=Inactive. 1=Active.			
14	Cooling boost regulation mode.	0 - 5	R/W	PV 5.00

Internal Integer (ADI).Signed 16bit.

N2 Idx	Name	Min/Max	R/W	Misc
	Setting of cooling boost regulation type. 0=Inactive. 1=Comfort. 2=Economy. 3=Sequence. 4=Comfort+economy (New in PV 5.00). 5=Economy+sequence (New in PV 5.00).			
15	Filter calibration mode	0 - 5	R/W	PV 5.00
	Setting for required filter calibration. 0=Inactive. 1=SA+EA-Filter. 2=SA-Filter. 3=EA-Filter. 4=HX. 5=ReCO2 (New in PV 5.00).			
16	Air adjustment time, minutes	0 - 1727	R/W	
	Setting for amount of minutes to air adjustment function.			
17	Air adjustment time, hours	0 - 28	R/W	
	Setting for amount of hours to air adjustment function.			
18	Hand held terminal language	0 - 18	R/W	PV 5.01
	0=Svenska 1=Norsk 2=Dansk 3=Suomi 4=English 5=Français 6=Deutsch 7=Polski 8=Český 9=Italiano 10=Español 11=Português 12=Русский 13=Eesti 14=Latviesu 15=Lietiviu 16=Nederlands 17=Magyar (New in PV 5.00) 18=Türkçe (New in PV 5.01)			
19	Summer night cool start, hour	0-23	R/W	
	Setting for start time of summer night cooling function.			
20	Summer night cool start, minute	0-59	R/W	
	Setting for start time of summer night cooling function.			
21	Summer night cool stop, hour	0-23	R/W	
	Setting for stop time of summer night cooling function.			
22	Summer night cool stop, minute	0-59	R/W	
	Setting for stop time of summer night cooling function.			
23	Extra regulation sequence cool mode	0 - 2	R/W	

Internal Integer (ADI).Signed 16bit.

N2 Idx	Name	Min/Max	R/W	Misc
	Setting of extra regulation sequence cool type. 0=Inactive. 1=Comfort. 2=Economy.			
24	Extra regulation sequence heat mode	0 - 2	R/W	
	Setting of extra regulation sequence heat type. 0=Inactive. 1=Comfort. 2=Economy.			
25	Morning boost time, hours	0-23	R/W	
	Setting of morning boost time before normal operation.			
26	Morning boost time, minutes	0-59	R/W	
	Setting of morning boost time before normal operation.			
27	Startup time	0 - 600s	R/W	
	Setting of time for startup when the unit regulator is running with fixed signals.			
28	Start delay SA fan.	0 - 600s	R/W	
	Setting of start delay time for the supply air fan.			
29	Start delay EA fan.	0 - 600s	R/W	
	Setting of start delay time for the extract air fan after supply air fan has started.			
30	Programversion, HMI	0-10.00	R	
	Present programversion for the hand held terminal.			
31	Programversion, HMI-slave	0-10.00	R	
	Present programversion for the extra hand held terminal.			
32	Programversion, main controller.	0-10.00	R	
	Present programversion for the main control unit.			
33	Programversion, SA FC-1.	0-10.00	R	
	Present programversion for the supply air frequency converter no.1.			
34	Programversion, SA FC-2.	0-10.00	R	
	Present programversion for the supply air frequency converter no.2.			
35	Programversion, EA FC-1.	0-10.00	R	
	Present programversion for the extract air frequency converter no.1.			
36	Programversion, EA FC-2.	0-10.00	R	
	Present programversion for the extract air frequency converter no.2.			
37	Programversion, HX control unit	0-10.00	R	
	Present programversion for the rotary heat exchange control unit.			
38	Air flow unit	0 - 2	R/W	
	Setting of air flow unit presented in the unit's hand held terminal and WEB. 0=l/s. 1=m3/s. 2=m3/h.			
39	Reserve			PV 3.00

Internal Integer (ADI).Signed 16bit.

N2 Idx	Name	Min/Max	R/W	Misc																								
40	Year Setting for the unit's internal clock.	2000-2099	R/W																									
41	Month Setting for the unit's internal clock.	1-12	R/W																									
42	Date Setting for the unit's internal clock.	0-31	R/W																									
43	Weekday Present weekday for the unit's internal clock.	0 - 6	R																									
44	Hour Setting for the unit's internal clock.	0-23	R/W																									
45	Minute Setting for the unit's internal clock.	0-59	R/W																									
46	Second Setting for the unit's internal clock.	0-59	R/W																									
47	Time channel 1 status <table border="0" style="width: 100%;"> <tr> <td>Low speed</td> <td>High speed</td> </tr> <tr> <td>0=Inactive</td> <td>16=Inactive</td> </tr> <tr> <td>1=Monday</td> <td>17=Monday</td> </tr> <tr> <td>2=Tuesday</td> <td>18=Tuesday</td> </tr> <tr> <td>3=Wednesday</td> <td>19=Wednesday</td> </tr> <tr> <td>4=Thursday</td> <td>20=Thursday</td> </tr> <tr> <td>5=Friday</td> <td>21=Friday</td> </tr> <tr> <td>6=Saturday</td> <td>22=Saturday</td> </tr> <tr> <td>7=Sunday</td> <td>23=Sunday</td> </tr> <tr> <td>8=Monday..Friday</td> <td>24=Monday..Friday</td> </tr> <tr> <td>9=Monday..Sunday</td> <td>25=Monday..Sunday</td> </tr> <tr> <td>10=Saturday..Sunday</td> <td>26=Saturday..Sunday</td> </tr> </table>	Low speed	High speed	0=Inactive	16=Inactive	1=Monday	17=Monday	2=Tuesday	18=Tuesday	3=Wednesday	19=Wednesday	4=Thursday	20=Thursday	5=Friday	21=Friday	6=Saturday	22=Saturday	7=Sunday	23=Sunday	8=Monday..Friday	24=Monday..Friday	9=Monday..Sunday	25=Monday..Sunday	10=Saturday..Sunday	26=Saturday..Sunday	0-10,16-26	R/W	
Low speed	High speed																											
0=Inactive	16=Inactive																											
1=Monday	17=Monday																											
2=Tuesday	18=Tuesday																											
3=Wednesday	19=Wednesday																											
4=Thursday	20=Thursday																											
5=Friday	21=Friday																											
6=Saturday	22=Saturday																											
7=Sunday	23=Sunday																											
8=Monday..Friday	24=Monday..Friday																											
9=Monday..Sunday	25=Monday..Sunday																											
10=Saturday..Sunday	26=Saturday..Sunday																											
48	Time channel 1 start hour	0-23	R/W																									
49	Time channel 1 start minute	0-59	R/W																									
50	Time channel 1 stop hour	0-23	R/W																									
51	Time channel 1 stop minute	0-59	R/W																									
52	Time channel 2 status	0-10,16-26	R/W																									
53	Time channel 2 start hour	0-23	R/W																									
54	Time channel 2 start minute	0-59	R/W																									
55	Time channel 2 stop hour	0-23	R/W																									
56	Time channel 2 stop minute	0-59	R/W																									
57	Time channel 3 status	0-10,16-26	R/W																									
58	Time channel 3 start hour	0-23	R/W																									
59	Time channel 3 start minute	0-59	R/W																									
60	Time channel 3 stop hour	0-23	R/W																									
61	Time channel 3 stop minute	0-59	R/W																									
62	Time channel 4 status	0-10,16-26	R/W																									
63	Time channel 4 start hour	0-23	R/W																									
64	Time channel 4 start minute	0-59	R/W																									
65	Time channel 4 stop hour	0-23	R/W																									
66	Time channel 4 stop minute	0-59	R/W																									
67	Time channel 5 status	0-10,16-26	R/W																									
68	Time channel 5 start hour	0-23	R/W																									
69	Time channel 5 start minute	0-59	R/W																									

Internal Integer (ADI).Signed 16bit.

N2 Idx	Name	Min/Max	R/W	Misc
70	Time channel 5 stop hour	0-23	R/W	
71	Time channel 5 stop minute	0-59	R/W	
72	Time channel 6 status	0-10,16-26	R/W	
73	Time channel 6 start hour	0-23	R/W	
74	Time channel 6 start minute	0-59	R/W	
75	Time channel 6 stop hour	0-23	R/W	
76	Time channel 6 stop minute	0-59	R/W	
77	Time channel 7 status	0-10,16-26	R/W	
78	Time channel 7 start hour	0-23	R/W	
79	Time channel 7 start minute	0-59	R/W	
80	Time channel 7 stop hour	0-23	R/W	
81	Time channel 7 stop minute	0-59	R/W	
82	Time channel 8 status	0-10,16-26	R/W	
83	Time channel 8 start hour	0-23	R/W	
84	Time channel 8 start minute	0-59	R/W	
85	Time channel 8 stop hour	0-23	R/W	
86	Time channel 8 stop minute	0-59	R/W	
87	Extended low speed op. Hours	0-23	R/W	
	Setting for extended low speed operation.			
88	Extended low speed op. Minutes	0-59	R/W	
	Setting for extended low speed operation.			
89	Extended low speed op. Hours	0-23	R	
	Present time for extended low speed operation.			
90	Extended low speed op. Minutes	0-59	R	
	Present time for extended low speed operation.			
91	Extended high speed op. Hours	0-23	R/W	
	Setting for extended low speed operation.			
92	Extended high speed op. Minutes	0-59	R/W	
	Setting for extended low speed operation.			
93	Extended high speed op. Hours	0-23	R	
	Present time for extended high speed operation.			
94	Extended high speed op. Minutes	0-59	R	
	Present time for extended high speed operation.			
95	Communication operation mode	0 - 4	R/W	PV 5.00
	Setting of unit operation mode from communication. 0=Auto operation (Normal stop when time channels are deactivated). 1=Communication stop 1. 2=Communication low speed. 3=Communication high speed. 4=Communication stop 2 (New in PV 5.00). Intermittent night heat and morning boost functions works at stop 2.			
96	SA Fan operation time	0-9999	R	
	Present operation time for the supply air fan, measured in minutes and present in days (24h).			
97	EA Fan operation time	0-9999	R	
	Present operation time for the extract air fan, measured in minutes and present in days (24h).			

Internal Integer (ADI).Signed 16bit.

N2 Idx	Name	Min/Max	R/W	Misc
98	Cool operation time	0-9999	R	
	Present operation time for cooling, measured in minutes and present in days (24h).			
99	Heat exchange operation time	0-9999	R	
	Present operation time for heat exchange, measured in minutes and present in days (24h).			
100	Reheat operation time	0-9999	R	
	Present operation time for reheat, measured in minutes and present in days (24h).			
101	Present tripped alarm	0-200	R	PV 5.00
	Present tripped alarm number with highest priority.			
102	Active not tripped alarm no.1	0-200	R	PV 5.00
	Present active alarm in delay.			
103	Active not tripped alarm no.2	0-200	R	PV 5.00
	Present active alarm in delay.			
104	Active not tripped alarm no.3	0-200	R	PV 5.00
	Present active alarm in delay.			
105	Service period alarm.	0-99	R/W	
	Setting for delay time in months before service alarm.			
106	External alarm 1 delay	1 - 600s	R/W	
	Setting of delay time for external alarm no 1			
107	External alarm 2 delay	1 - 600s	R/W	
	Setting of delay time for external alarm no 2			
108	SA Fan size	04 - 120	R	
	Present supply air fan size.			
109	EA Fan size	04 - 120	R	
	Present extract air fan size.			
110	Operation mode 1	0 - 18	R	PV 5.00
	0=Manual stop. 1=Ext. stop. 2=Com. stop 1. 3=Manual high speed. 4=Summer night cooling. 5=Int. night heat. 6=Manual low speed. 7=Ext. high speed. 8=Com. high speed. 9=Year channel stop. 10=Year channel high speed. 11=Year channel low speed. 12=Time channel high speed. 13=Ext. low speed. 14=Com. low speed. 15=Time channel low speed. 16=Time channel stop. 17=Low speed=stop. 18=Com. stop 2. (New in PV 5.00)			
111	Operation mode 2	0 - 22	R	PV 5.00

Internal Integer (ADI).Signed 16bit.

N2 Idx	Name	Min/Max	R/W	Misc
	0= 1=Cold air recovery. 2=Cooling boost. 3=SA down regulation. 4=HX defrosting. 5=Anti frost func. active. 6=Effect reduction. 7=Startup. 8=Zero calibration. 9=Extended low speed. 10=Extended high speed. 11=Air adjustment. 12=Cooling off. 13=Purging R.HX. 14=Extended R.HX. op. 15=Filter calibration. 16=R.HX. calibration 17=Morning boost. 18=Heating boost. 19=Alarm. 20=CoolDX pressure reduction. (PV 2.00) 21=Startup extract air fan (New in 4.00) R.HX speed limited. (Only in PV 2.00-2.02) 22=Fan heat retention (New in PV 5.00)			
112	Operation mode, manual	0 - 3	R	
	Present manual operation set on the unit's hand held terminal. 0=Stop. 1=Auto operation. 2=Manual low speed. 3=Manual high speed.			
113	Copy of Binary Input 1-16	0-65535	R	
	Bit 0 = Binary Input 1			
	Bit 1 = Binary Input 2			
	Bit 15 = Binary Input 16			
114	Copy of Binary Input 17-32	0-65535	R	
	Bit 0 = Binary Input 17			
	Bit 1 = Binary Input 18			
	Bit 15 = Binary Input 32			
115	Copy of Binary Input 33-48	0-65535	R	
	Bit 0 = Binary Input 33			
	Bit 1 = Binary Input 34			
	Bit 15 = Binary Input 48			
116	Copy of Binary Output 1-16	0-65535	R/W	
	Bit 0 = Binary Output 1			
	Bit 1 = Binary Output 2			
	Bit 15 = Binary Output 16			
117	Copy of Binary Output 17-32	0-65535	R/W	
	Bit 0 = Binary Output 17			
	Bit 1 = Binary Output 18			

Internal Integer (ADI).Signed 16bit.

N2 Idx	Name	Min/Max	R/W	Misc
	Bit 15 = Binary Output 32			
118	Copy of Binary Output 33-48	0-65535	R/W	
	Bit 0 = Binary Output 33			
	Bit 1 = Binary Output 34			
	Bit 15 = Binary Output 48			
119	Heat relay periodic func.	0-3	R/W	PV 2.02
	Setting of periodic operation. 0=Inactive 1=Pump 2=Pump+valve 3=Valve (PV 2.02)			
120	Cool relay 1 periodic func.	0-3	R/W	PV 2.02
	Setting of periodic operation. 0=Inactive 1=Pump 2=Pump+valve 3=Valve (PV 2.02)			
121	Cool relay 2 periodic func.	0-3	R/W	PV 2.02
	Setting of periodic operation. 0=Inactive 1=Pump 2=Pump+valve 3=Valve (PV 2.02)			
122	Cool periodic op. time	0-60min	R/W	PV 2.02
	Setting of periodic op. time (minute).			
123	Cool interval	0-168h	R/W	PV 2.02
	Setting of cool interval time (hour).			
124	EA/Room temperature (external) func.	0-3	R/W	PV 5.15
	Setting of EA/Room temperature (external) function. 0=Inactive. 1=Input signal on terminal 40..41. 2=Communication (Vpac 5 index 123). 3=Min/Max/Average (PV 5.15).			
125	Outdoor temperature (external) func.	0-2	R/W	PV 3.00
	Setting of outdoor temperature (external) function. 0=Inactive. 1=Input signal on terminal 38..39. 2=Communication (AO 113).			
126	Timeout temperature com.	0-9999min	R/W	PV 3.00
	Setting of timeout for temperature via communication (AO 112, AO 113).			
127	Flow at fire function.	0-3	R/W	PV 3.00
	Setting for activating the air fan operation at fire function 0=Inactive. 1=SA. 2=EA. 3=SA+EA.			
128	Air fan down regulation func.	0-2	R/W	PV 3.00

Internal Integer (ADI).Signed 16bit.

N2 Idx	Name	Min/Max	R/W	Misc
	Setting for activating the air fan down regulation function 0=Inactive. 1=SA. 2=SA+EA.			
129	Temperature alarm time.	1-999s	R/W	PV 3.00
	Setting of delay time for temperature alarm (no.80).			
130	Year channel 1 function.	0 - 3	R/W	PV 3.00
	0=Inactive. 1=Stop. 2=Low speed. 3=High speed.			
131	Year channel 1 start year.	2000 - 2099	R/W	PV 3.00
132	Year channel 1 start month.	1 - 12	R/W	PV 3.00
133	Year channel 1 start date.	1 - 31	R/W	PV 3.00
134	Year channel 1 start hour.	0 - 23	R/W	PV 3.00
135	Year channel 1 start minute.	0 - 59	R/W	PV 3.00
136	Year channel 1 stop year.	2000 - 2099	R/W	PV 3.00
137	Year channel 1 stop month.	1 - 12	R/W	PV 3.00
138	Year channel 1 stop date.	1 - 31	R/W	PV 3.00
139	Year channel 1 stop hour.	0 - 23	R/W	PV 3.00
140	Year channel 1 stop minute.	0 - 59	R/W	PV 3.00
141	Year channel 2 function.	0 - 3	R/W	PV 3.00
142	Year channel 2 start year.	2000 - 2099	R/W	PV 3.00
143	Year channel 2 start month.	1 - 12	R/W	PV 3.00
144	Year channel 2 start date.	1 - 31	R/W	PV 3.00
145	Year channel 2 start hour.	0 - 23	R/W	PV 3.00
146	Year channel 2 start minute.	0 - 59	R/W	PV 3.00
147	Year channel 2 stop year.	2000 - 2099	R/W	PV 3.00
148	Year channel 2 stop month.	1 - 12	R/W	PV 3.00
149	Year channel 2 stop date.	1 - 31	R/W	PV 3.00
150	Year channel 2 stop hour.	0 - 23	R/W	PV 3.00
151	Year channel 2 stop minute.	0 - 59	R/W	PV 3.00
152	Year channel 3 function.	0 - 3	R/W	PV 3.00
153	Year channel 3 start year.	2000 - 2099	R/W	PV 3.00
154	Year channel 3 start month.	1 - 12	R/W	PV 3.00
155	Year channel 3 start date.	1 - 31	R/W	PV 3.00
156	Year channel 3 start hour.	0 - 23	R/W	PV 3.00
157	Year channel 3 start minute.	0 - 59	R/W	PV 3.00
158	Year channel 3 stop year.	2000 - 2099	R/W	PV 3.00
159	Year channel 3 stop month.	1 - 12	R/W	PV 3.00
160	Year channel 3 stop date.	1 - 31	R/W	PV 3.00
161	Year channel 3 stop hour.	0 - 23	R/W	PV 3.00
162	Year channel 3 stop minute.	0 - 59	R/W	PV 3.00
163	Year channel 4 function.	0 - 3	R/W	PV 3.00
164	Year channel 4 start year.	2000 - 2099	R/W	PV 3.00
165	Year channel 4 start month.	1 - 12	R/W	PV 3.00
166	Year channel 4 start date.	1 - 31	R/W	PV 3.00
167	Year channel 4 start hour.	0 - 23	R/W	PV 3.00
168	Year channel 4 start minute.	0 - 59	R/W	PV 3.00
169	Year channel 4 stop year.	2000 - 2099	R/W	PV 3.00

Internal Integer (ADI).Signed 16bit.

N2 Idx	Name	Min/Max	R/W	Misc
170	Year channel 4 stop month.	1 - 12	R/W	PV 3.00
171	Year channel 4 stop date.	1 - 31	R/W	PV 3.00
172	Year channel 4 stop hour.	0 - 23	R/W	PV 3.00
173	Year channel 4 stop minute.	0 - 59	R/W	PV 3.00
174	Year channel 5 function.	0 - 3	R/W	PV 3.00
175	Year channel 5 start year.	2000 - 2099	R/W	PV 3.00
176	Year channel 5 start month.	1 - 12	R/W	PV 3.00
177	Year channel 5 start date.	1 - 31	R/W	PV 3.00
178	Year channel 5 start hour.	0 - 23	R/W	PV 3.00
179	Year channel 5 start minute.	0 - 59	R/W	PV 3.00
180	Year channel 5 stop year.	2000 - 2099	R/W	PV 3.00
181	Year channel 5 stop month.	1 - 12	R/W	PV 3.00
182	Year channel 5 stop date.	1 - 31	R/W	PV 3.00
183	Year channel 5 stop hour.	0 - 23	R/W	PV 3.00
184	Year channel 5 stop minute.	0 - 59	R/W	PV 3.00
185	Year channel 6 function.	0 - 3	R/W	PV 3.00
186	Year channel 6 start year.	2000 - 2099	R/W	PV 3.00
187	Year channel 6 start month.	1 - 12	R/W	PV 3.00
188	Year channel 6 start date.	1 - 31	R/W	PV 3.00
189	Year channel 6 start hour.	0 - 23	R/W	PV 3.00
190	Year channel 6 start minute.	0 - 59	R/W	PV 3.00
191	Year channel 6 stop year.	2000 - 2099	R/W	PV 3.00
192	Year channel 6 stop month.	1 - 12	R/W	PV 3.00
193	Year channel 6 stop date.	1 - 31	R/W	PV 3.00
194	Year channel 6 stop hour.	0 - 23	R/W	PV 3.00
195	Year channel 6 stop minute.	0 - 59	R/W	PV 3.00
196	Year channel 7 function.	0 - 3	R/W	PV 3.00
197	Year channel 7 start year.	2000 - 2099	R/W	PV 3.00
198	Year channel 7 start month.	1 - 12	R/W	PV 3.00
199	Year channel 7 start date.	1 - 31	R/W	PV 3.00
200	Year channel 7 start hour.	0 - 23	R/W	PV 3.00
201	Year channel 7 start minute.	0 - 59	R/W	PV 3.00
202	Year channel 7 stop year.	2000 - 2099	R/W	PV 3.00
203	Year channel 7 stop month.	1 - 12	R/W	PV 3.00
204	Year channel 7 stop date.	1 - 31	R/W	PV 3.00
205	Year channel 7 stop hour.	0 - 23	R/W	PV 3.00
206	Year channel 7 stop minute.	0 - 59	R/W	PV 3.00
207	Year channel 8 function.	0 - 3	R/W	PV 3.00
208	Year channel 8 start year.	2000 - 2099	R/W	PV 3.00
209	Year channel 8 start month.	1 - 12	R/W	PV 3.00
210	Year channel 8 start date.	1 - 31	R/W	PV 3.00
211	Year channel 8 start hour.	0 - 23	R/W	PV 3.00
212	Year channel 8 start minute.	0 - 59	R/W	PV 3.00
213	Year channel 8 stop year.	2000 - 2099	R/W	PV 3.00
214	Year channel 8 stop month.	1 - 12	R/W	PV 3.00
215	Year channel 8 stop date.	1 - 31	R/W	PV 3.00
216	Year channel 8 stop hour.	0 - 23	R/W	PV 3.00
217	Year channel 8 stop minute.	0 - 59	R/W	PV 3.00
218	Filter select.	0 - 3	R/W	PV 5.00

Internal Integer (ADI).Signed 16bit.

N2 Idx	Name	Min/Max	R/W	Misc
	Setting for filter select function. 0=Inactive. 1=Supply air. 2=Extract air. 3=SA+EA.			
219	Pre-filter select.	0 - 3	R/W	PV 5.00
	Setting for pre-filter select function. 0=Inactive. 1=Supply air. 2=Extract air. 3=SA+EA.			
220	Pre-filter calibration mode.	0 - 3	R/W	PV 5.00
	Setting for required filtercalibration. 0=Inactive. 1=SA+EA-Filter. 2=SA-Filter. 3=EA-Filter.			
221	Xzone cool step time	0-600s	R	PV 5.00
	Present time between Xzone cool step shift.			
222	Xzone cool relay 1 restart time	0-900s	R	PV 5.00
	Present time between two starts of Xzone cool relay 1.			
223	Xzone cool relay 2 restart time	0-900s	R	PV 5.00
	Present time between two starts of Xzone cool relay 2.			
224	Xzone reheat function.	0 - 4	R/W	PV 5.00
	Setting for Xzone reheat function. 0=Inactive. 1=El. coil P/P. 2=El. coil 0-10V. 3=Water coil with FP. 4=Water coil without FP.			
225	Xzone cooling function.	0 - 5	R/W	PV 5.00
	Setting for Xzone cooling function. 0=Inactive. 1=0-10V. 2=10-0V. 3=On/off 1. 4=On/off 2. 5=On/off 3.			
226	Xzone temperature regulation mode.	0 - 3	R/W	PV 5.00
	Setting of Xzone temperature regulation type. 0=ERS 1 reg. 1=ERS 2 reg. 2=SA reg. 3=EA/Room reg.			
227	Xzone ERS Step.	1 - 4	R/W	PV 5.00
	Setting of Xzone curve when temperature is above breakpoint.			
228	Pre-heating function.	0 - 4	R/W	PV 5.00

Internal Integer (ADI).Signed 16bit.

N2 Idx	Name	Min/Max	R/W	Misc
	Setting of pre-heating function. 0=Inactive. 1=El. coil P/P. 2=El. coil 0-10V. 3=Water coil with FP. 4=Water coil without FP.			
229	ReCO2 CO2 function.	0 - 2	R/W	PV 5.00
	Setting of ReCO2 CO2 function. 0=Inactive. 1=CO2. 2=CO2+flow.			
230	ReCO2 cooling function.	0 - 2	R/W	PV 5.00
	Setting of ReCO2 cooling function. 0=Inactive. 1=Comfort. 2=Economy.			
231	ReCO2 heating function.	0 - 2	R/W	PV 5.00
	Setting of ReCO2 heating function. 0=Inactive. 1=Comfort. 2=Economy.			
232	Pre-heat operation time	0-9999	R	PV 5.00
	Present operation time for pre-heat, measured in minutes and present in days (24h).			
233	Xzone cool operation time	0-9999	R	PV 5.00
	Present operation time for Xzone cooling, measured in minutes and present in days (24h).			
234	Xzone reheat operation time	0-9999	R	PV 5.00
	Present operation time for Xzone reheat, measured in minutes and present in days (24h).			
235	AYC function.	0 - 3	R/W	PV 5.07
	Setting of AYC function. 0=Inactive. 1=Cool. 2=Heat. 3=Cool+heat.			
236	AYC night comp. channel.	1 - 2	R/W	PV 5.07
	Setting of AYC night compensation channel. 1=Channel 1. 2=Channel 2.			
237	AYC channel start hour.	0-23h	R/W	PV 5.07
	Setting of AYC channel start time (hour).			
238	AYC channel start minute.	0-59min	R/W	PV 5.07
	Setting of AYC channel start time (minute).			
239	AYC channel stop hour.	0-23h	R/W	PV 5.07
	Setting of AYC channel stop time (hour).			
240	AYC channel stop minute.	0-59min	R/W	PV 5.07
	Setting of AYC channel stop time (minute).			
241	AYC channel period.	0-10	R/W	PV 5.07

Internal Integer (ADI).Signed 16bit.

N2 Idx	Name	Min/Max	R/W	Misc
	Setting of AYC channel period. 0=Inactive 1=Monday 2=Tuesday 3=Wednesday 4=Thursday 5=Friday 6=Saturday 7=Sunday 8=Monday..Friday 9=Monday..Sunday 10=Saturday..Sunday			
242	AYC heat pump alarm.	0 - 3	R/W	PV 5.07
	Setting for selecting the AYC heated water pump alarm function. 0=Inactive. 1=Open. 2=Closed. 3=Contactor.			
243	AYC heat per op function.	0 - 3	R/W	PV 5.07
	Setting for selecting the AYC heated water periodic operation function. 0=Inactive. 1=Pump. 2=Pump+valve. 3=Valve.			
244	AYC heat per op time.	0-60min	R/W	PV 5.07
	AYC periodic operation of heated water, time (minute) setting.			
245	AYC heat per op interval.	0-168h	R/W	PV 5.07
	AYC periodic operation of heated water, interval time (hour) setting.			
246	AYC cool pump alarm.	0 - 3	R/W	PV 5.07
	Setting for selecting the AYC chilled water pump alarm function. 0=Inactive. 1=Open. 2=Closed. 3=Contactor.			
247	AYC cool per op function.	0 - 3	R/W	PV 5.07
	Setting for selecting the AYC chilled water periodic operation function. 0=Inactive. 1=Pump. 2=Pump+valve. 3=Valve.			
248	AYC cool per op time.	0-60min	R/W	PV 5.07
	AYC periodic operation of chilled water, time (minute) setting.			
249	AYC cool per op interval.	0-168h	R/W	PV 5.07

Internal Integer (ADI).Signed 16bit.

N2 Idx	Name	Min/Max	R/W	Misc
	AYC periodic operation of chilled water, interval time (hour) setting.			
250	IO-mod 3 output 1 function.	0 - 10	R/W	PV 5.07
	Setting of I/O-module no. 3 relay 1 output. 0=Cooling boost. 1=Heating boost. 2=Cooling. 3=Heat exchange. 4=Reheat. 5=Down regulation. 6=Effect reduction. 7=Intermittent night heat. 8=Summer night cooling. 9=Morning boost. 10=Heat exchange defrost.			
251	IO-mod 3 output 2 function.	0 - 10	R/W	PV 5.07
	Setting of I/O-module no. 3 relay 2 output. 0=Cooling boost. 1=Heating boost. 2=Cooling. 3=Heat exchange. 4=Reheat. 5=Down regulation. 6=Effect reduction. 7=Intermittent night heat. 8=Summer night cooling. 9=Morning boost. 10=Heat exchange defrost.			
252	Humid reg. func.	0 - 3	R/W	PV 6.07
	Setting for selecting humidifying function. 0=Inactive. 1=Supply air. 2=Extract air. 3=Steam (New in PV 6.07)			
253	Min/Max/Average Sens Number	1 - 4	R/W	PV 5.15
	Setting for selecting numbers of sensors to the Min/Max/Average function.			
254	Min/Max/Average Sens Function	0 - 2	R/W	PV 5.15
	Setting for selecting sensor function. 0=Min. 1=Max. 2=Average.			

Binary Input (BI).1bit (RO).

N2 Idx	Name	Min/Max	Misc
1	Heat output Status for relay output.	0-1	
2	Cool output 1 Status for relay output.	0-1	
3	Cool output 2 Status for relay output.	0-1	
4	Low speed output Status for relay output.	0-1	
5	High speed output Status for relay output.	0-1	
6	A-alarm. Status for relay output.	0-1	
7	B-alarm. Status for relay output.	0-1	
8	Operation output Status for relay output.	0-1	
9	Damper output Status for relay output.	0-1	
10	External low speed input Status for digital input.	0-1	
11	External high speed input Status for digital input.	0-1	
12	External alarm 1 input Status for digital input.	0-1	
13	External alarm 2 input Status for digital input.	0-1	
14	External fire alarm input. Status for digital input.	0-1	
15	External stop input Status for digital input.	0-1	
16	DIP Switch 1 Status for dip switch setting.	0-1	
17	DIP Switch 2 Status for dip switch setting.	0-1	
18	DIP Switch 3 Status for dip switch setting.	0-1	
19	DIP Switch 4 Status for dip switch setting.	0-1	
20	DIP Switch 5 Status for dip switch setting.	0-1	
21	DIP Switch 6 Status for dip switch setting.	0-1	
22	AYC heat pump output Status for AYC heat pump output.	0-1	PV 5.07
23	AYC cool pump output Status for AYC cool pump output.	0-1	PV 5.07
24	C.HX. pump output Status for coil heat exchanger pump output.	0-1	PV 2.00
25	R.HX rotation monitor Status from the rotation detector.	0-1	PV 3.00

Binary Input (BI).1bit (RO).

N2 Idx	Name	Min/Max	Misc
26	Xzone heat output Status for relay output.	0-1	PV 5.00
27	Xzone cool output 1 Status for relay output.	0-1	PV 5.00
28	Xzone cool output 2 Status for relay output.	0-1	PV 5.00
29	Pre-heat output Status for relay output.	0-1	PV 5.00
30	IO-mod 3 output 1 Status for I/O-module no. 3 relay 1 output.	0-1	PV 5.07
31	IO-mod 3 output 2 Status for I/O-module no. 3 relay 2 output.	0-1	PV 5.07
32	IO-mod 4 output 1 Status for I/O-module no. 4 relay 1 output.	0-1	PV 5.10
33	Reserve 12		
34	Reserve 13		
35	Reserve 14		
36	Reserve 15		
37	Reserve 16		
38	Reserve 17		
39	Reserve 18		
40	Reserve 19		
41	Reserve 20		
42	Reserve 21		
43	Reserve 22		
44	Reserve 23		
45	Reserve 24		
46	Reserve 25		
47	Reserve 26		
48	Reserve 27		
49	Alarm number 1 Status if alarm number 1 is active.	0-1	
50	Alarm number 2 Status if alarm number 2 is active.	0-1	

Binary Input (BI).1bit (RO).

N2 Idx	Name	Min/Max	Misc
51	Alarm number 3	0-1	
	Status if alarm number 3 is active.		
228	Alarm number 180	0-1	PV 5.00
	Status if alarm number 180 is active.		
229	Info number 1	0-1	PV 5.00
	Status if info number 1 is active.		
230	Info number 2	0-1	PV 5.00
	Status if info number 2 is active.		
231	Info number 3	0-1	PV 5.00
	Status if info number 3 is active.		
248	Info number 20	0-1	PV 5.00
	Status if info number 20 is active.		

Analog Output (AO).32bit IEEE-standard floats (R/W).

N2 Idx	Name	Min/Max	Misc
1	SA Low speed airflow setpoint Supply airflow setpoint for the unit when running in low speed operation.	0-8200l/s	
2	SA High speed airflow setpoint Supply airflow setpoint for the unit when running in high speed operation.	0-8200l/s	
3	SA Max speed airflow setpoint Supply airflow max. limit for the unit when the low/high speed operation setpoint is altered by boosting function etc.	0-8200l/s	
4	SA Min speed airflow setpoint Supply airflow min. limit for the unit when the low/high speed operation setpoint is altered when running in fan regulation mode VAV demand.	0-8200l/s	
5	EA Low speed airflow setpoint Extract airflow setpoint for the unit when running in low speed operation.	0-8200l/s	
6	EA High speed airflow setpoint Extract airflow setpoint for the unit when running in high speed operation.	0-8200l/s	
7	EA Max speed airflow setpoint Extract airflow max. limit for the unit when the low/high speed operation setpoint is altered by boosting function etc.	0-8200l/s	
8	EA Min speed airflow setpoint Extract airflow min. limit for the unit when the low/high speed operation setpoint is altered when running in fan regulation mode VAV demand.	0-8200l/s	
9	SA Low speed pressure setpoint Supply air duct pressure setpoint for the unit when running in low speed operation.	0-750Pa	
10	SA High speed pressure setpoint Supply air duct pressure for the unit when running in high speed operation.	20-750Pa	
11	SA Max speed output signal Max. limit for the supply air fan speed when running in pressure regulation mode.	10.00-100.00%	
12	SA Max speed pressure setpoint Supply air duct pressure max. limit for the unit when the low/high speed operation setpoint is altered by boosting function etc.	20-750Pa	
13	EA Low speed pressure setpoint Extract air duct pressure setpoint for the unit when running in low speed operation.	0-750Pa	
14	EA High speed pressure setpoint Extract air duct pressure setpoint for the unit when running in high speed operation.	20-750Pa	
15	EA Max speed output signal Max. limit for the extract air fan speed when running in pressure regulation mode.	10.00-100.00%	
16	EA Max speed pressure setpoint	20-750Pa	

Analog Output (AO).32bit IEEE-standard floats (R/W).

N2 Idx	Name	Min/Max	Misc
	Extract air duct pressure max. limit for the unit when the low/high speed operation setpoint is altered by boosting function etc.		
17	SA Low speed demand setpoint	0-100.00%	
	Supply air setpoint for the 0-10V input signal on terminal 30..31 for the unit when running in low speed operation.		
18	SA High speed demand setpoint	0-100.00%	
	Supply air setpoint for the 0-10V input signal on terminal 30..31 for the unit when running in high speed operation.		
19	EA Low speed demand setpoint	0-100.00%	
	Extract air setpoint for the 0-10V input signal on terminal 32..33 for the unit when running in low speed operation.		
20	EA High speed demand setpoint	0-100.00%	
	Extract air setpoint for the 0-10V input signal on terminal 32..33 for the unit when running in high speed operation.		
21	SA Airflow regulation zone	1.00 - 10.00	
	Supply airflow regulation zone setting in % of the present airflow setpoint that the regulator is allowed to work within.		
22	SA Airflow C-factor	0.005 - 2.500	
	Supply airflow regulator affection setting.		
23	EA Airflow regulation zone	1.00 - 10.00	
	Extract airflow regulation zone setting in % of the present airflow setpoint that the regulator is allowed to work within.		
24	EA Airflow C-factor	0.005 - 2.500	
	Extract airflow regulator affection setting.		
25	SA Pressure regulation zone	1.00 - 10.00	
	Supply air pressure regulation zone setting in % of the present duct pressure setpoint that the regulator is allowed to work within.		
26	SA Pressure C-factor	0.005 - 2.500	
	Supply air pressure regulator affection setting.		
27	EA Pressure regulation zone	1.00 - 10.00	
	Extract air pressure regulation zone setting in % of the present duct pressure setpoint that the regulator is allowed to work within.		
28	EA Pressure C-factor	0.005 - 2.500	
	Extract air pressure regulator affection setting.		
29	SA Demand P-band.	1.00 - 100.00	
	Supply air demand regulator P-band setting.		
30	SA Demand C-factor	0.005 - 2.500	
	Supply air demand regulator affection setting.		
31	EA Demand P-band.	1.00 - 100.00	
	Extract air demand regulator P-band setting.		
32	EA Demand C-factor	0.005 - 2.500	
	Extract air demand regulator affection setting.		
33	ERS 1 Diff	1.00 - 7.00°C	
	Supply air temperature difference setting according to the diagram for ERS 1.		
34	ERS 1 Breakpoint	12.00 - 26.00°C	
	Breakpoint setting according to the diagram for ERS 1.		

Analog Output (AO).32bit IEEE-standard floats (R/W).

N2 Idx	Name	Min/Max	Misc
35	ERS 2 Breakpoint X1	10.00-38.00°C	
	Breakpoint X1 setting according to the diagram for ERS 2.		
36	ERS 2 Breakpoint Y1	10.00-40.00°C	
	Breakpoint Y1 setting according to the diagram for ERS 2.		
37	ERS 2 Breakpoint X2	11.00-39.00°C	
	Breakpoint X2 setting according to the diagram for ERS 2.		
38	ERS 2 Breakpoint Y2	10.00-40.00°C	
	Breakpoint Y2 setting according to the diagram for ERS 2.		
39	ERS 2 Breakpoint X3	12.00-40.00°C	
	Breakpoint X3 setting according to the diagram for ERS 2.		
40	ERS 2 Breakpoint Y3	10.00-40.00°C	
	Breakpoint Y3 setting according to the diagram for ERS 2.		
41	SA Temperature setpoint	10.00-40.00°C	
	Supply air temperature setting,		
42	EA/Room Temperature setpoint	10.00-40.00°C	
	Extract air/room temperature setting, for Extract air/room temp regulation mode.		
43	SA Min temp setpoint	8.00-20.00°C	
	Supply air min.setpoint during EA/room regulation mode.		
44	SA Max temp setpoint	16.00-50.00°C	
	Supply air max.setpoint during EA/room regulation mode.		
45	SA Temperature P-band	1.00 - 40.00	PV 5.00
	Supply air temperature regulator P-band setting.		
46	EA/Room Temperature P-band	1.00 - 40.00	PV 5.00
	Extract air/room temperature regulator P-band setting.		
47	SA HX. Reg C-factor	0.000 - 2.500	
	Supply air heat exchange regulator affection setting.		
48	EA/Room HX. Reg C-factor	0.000 - 2.500	
	Extract air/room heat exchange regulator affection setting.		
49	SA Heat Reg C-factor	0.000 - 2.500	
	Supply air reheat regulator affection setting.		
50	EA/Room Heat Reg C-factor	0.000 - 2.500	
	Extract air/room reheat regulator affection setting.		
51	SA Extra Reg heat C-factor	0.000 - 2.500	
	Supply air extra regulation sequence for reheating regulator affection setting.		
52	SA Extra Reg cool C-factor	0.000 - 2.500	
	Supply air extra regulation sequence for cooling regulator affection setting.		
53	EA Extra Reg heat C-factor	0.000 - 2.500	
	Extract air extra regulation sequence for reheating regulator affection setting.		
54	EA Extra Reg cool C-factor	0.000 - 2.500	
	Extract air extra regulation sequence for cooling regulator affection setting.		
55	SA Down regulation Reg C-factor	0.000 - 2.500	
	Supply air reheat regulator affection setting.		
56	Reserve		
57	SA Cool reg C-factor	0.000 - 2.500	

Analog Output (AO).32bit IEEE-standard floats (R/W).

N2 Idx	Name	Min/Max	Misc
	Supply air cool regulator affection setting.		
58	EA/Room Cool reg C-factor	0.000 - 2.500	
	Extract air/room cool regulator affection setting.		
59	SA Cooling boost C-factor	0.000 - 2.500	
	Supply air cooling boost affection setting.		
60	EA/Room Cooling boost reg C-factor	0.000 - 2.500	
	Extract air/room cooling boost regulator affection setting.		
61	HX Pressure alarm set.	30 - 100Pa	
	Heat exchange pressure alarm limit setting (alarm no.38).		
62	P/C.HX. defrost P-band	1.00 - 40.00	PV 2.00
	Plate/coil heat exchange defrost P-band setting.		
63	P/C.HX. defrost C-factor	0.000 - 2.500	PV 2.00
	Plate/coil heat exchange defrost C-factor setting.		
64	Cooling off set.	10 - 50%	
	Cooling off airflow setting in % of max. airflow.		
65	SA Down regulation neutral zone	0.00-10.00°C	
	Neutral zone setting before downregulation is permitted.		
66	Cool Outdoor temp limit.1	0.00-25.00°C	
	Outdoor temperature limit setting for cooling stage 1.		
67	Cool Outdoor temp limit.2	0.00-25.00°C	
	Outdoor temperature limit setting for cooling stage 2.		
68	Cool Outdoor temp limit.3	0.00-25.00°C	
	Outdoor temperature limit setting for cooling stage 3.		
69	Temperature reg. Neutral zone	0.50-10.00°C	
	Neutral zone setting before shift between heating and cooling.		
70	SA Cool min air flow	0-8200l/s	
	Supply air min. air flow setting for cooling.		
71	EA Cool min air flow	0-8200l/s	
	Extract air min. air flow setting for cooling.		
72	Heating boost start limit	0.00-40.00°C	
	Heating boost start temperature limit.		
73	Cooling boost start limit	0.00-40.00°C	
	Cooling boost (comfort) start temperature limit.		
74	SA Filter alarm limit	50-300Pa	
	Supply air filter pressure alarm limit setting.		
75	EA Filter alarm limit	50-300Pa	
	Extract air filter pressure alarm limit setting.		
76	Int. Night heat room start temp	5.00-25.00°C	
	Intermittent night heat function, extract air temperature setting for start.		
77	Int. Night heat room stop temp	5.00-25.00°C	
	Intermittent night heat function, extract air temperature setting for stop.		
78	Int. Night heat SA temp setpoint	5.00-40.00°C	
	Intermittent night heat function, supply air temperature setpoint during night heat.		
79	Int. Night heat SA airflow setpoint	0-8200l/s	
	Intermittent night heat function, supply airflow setpoint during night heat.		
80	Int. Night heat EA airflow setpoint	0-8200l/s	

Analog Output (AO).32bit IEEE-standard floats (R/W).

N2 Idx	Name	Min/Max	Misc
	Intermittent night heat function, extract airflow setpoint during night heat.		
81	Summer night cool EA start temp	17.00-27.00°C	
	Summer night cool function, extract air temperature setting for start.		
82	Summer night cool EA stop temp	12.00-22.00°C	
	Summer night cool function, extract air temperature setting for stop.		
83	Summer night cool outdoor temp limit	5.00-15.00°C	
	Summer night cool function, outdoor temperature limit.		
84	Summer night cool SA temp setpoint	10.00-20.00°C	
	Summer night cool function, supply air temperature setpoint during summer night cool.		
85	Outdoor temp comp. Winter X1.	-30.00-(-10.00)°C	
	Endpoint of winter compensation.		
86	Outdoor temp comp. Winter X2.	-10.00-15.00°C	
	Startpoint of winter compensation.		
87	Outdoor temp comp. Winter Y1.	0.00-10.00°C	
	Level of winter compensation at X1.		
88	Outdoor temp comp. Summer X3.	15.00-25.00°C	
	Startpoint of summer compensation.		
89	Outdoor temp comp. Summer X4.	25.00-40.00°C	
	Endpoint of summer compensation.		
90	Outdoor temp comp. Summer Y2.	-10.00-10.00°C	
	Level of summer compensation at X4.		
91	Outdoor airflow comp. Winter X1.	-30.00-(-10.00)°C	
	Endpoint of winter compensation.		
92	Outdoor airflow comp. Winter X2.	-10.00-15.00°C	
	Startpoint of winter compensation.		
93	Outdoor airflow comp. Winter Y1.	0-50.00%	
	Level of airflow compensation at X1.		
94	Extra Reg. Sequence max output	0-100.00%	
	Maximum output signal setting for the extra regulation sequence.		
95	EA/Room min temp alarm limit	8.00-20.00°C	
	Setting for min extract air /room temp alarm no.40.		
96	SA Deviation alarm limit	2.00-15.00°C	
	Setting for supply air temperature below present setpoint, alarm no.41.		
97	Reserve		
98	Int. Night heat SA pressure setpoint	20-750Pa	
	Intermittent night heat function, supply pressure setpoint during night heat.		
99	Int. Night heat EA pressure setpoint	20-750Pa	
	Intermittent night heat function, extract pressure setpoint during night heat.		
100	Slave control C-factor	0.5 - 2.0	PV 5.07
	Slave regulator affection setting.		
101	SA dehumid P-band	1.00 - 40.00	PV 5.00

Analog Output (AO).32bit IEEE-standard floats (R/W).

N2 Idx	Name	Min/Max	Misc
	SA dehumid regulator P-band setting.		
102	SA dehumid C-factor	0.000 - 2.500	
	SA dehumid regulator affection setting.		
103	Dewpoint reg. P-band	1.00 - 40.00	PV 5.00
	Dewpoint regulator P-band setting.		
104	Dewpoint reg. C-factor	0.000 - 2.500	
	Dewpoint regulator affection setting.		
105	AYC chilled water temperature	5.00-30.00°C	
	Setting of AYC chilled water temperature setpoint.		
106	Dewpoint neutralzone	0.00-5.00°C	
	Dewpoint neutralzone setting.		
107	Comp. airflow	0-30.00%	
	Setting of comp. airflow.		
108	Supply air-humidity	10.00-90.00%	
	Setting of supply air-humidity.		
109	Water heating periodic op. time	0-60min	
	Setting of periodic op. time (minute).		
110	Water heating interval	0-168h	
	Setting of water heating interval time (hour).		
111	P/C.HX. bypass adj.	-5.00-5.00°C	PV 2.02
	Setting of plate/coil heat exchange bypass adjustment.		
112	EA/Room temperature com.	-55.00-125.00°C	PV 3.00
	Setting of EA/Room temperature via communication.		
113	Outdoor temperature com.	-55.00-125.00°C	PV 3.00
	Setting of outdoor temperature via communication.		
114	SA speed at fire.	50.00-100.00%	PV 3.00
	Setting of supply air speed at fire.		
115	EA speed at fire.	50.00-100.00%	PV 3.00
	Setting of extract air speed at fire.		
116	Temperature alarm setpoint.	-25.00-25.00°C	PV 3.00
	Temperature alarm function setting (no.80).		
117	Supply air min P-band.	1.00 - 40.00	PV 3.00
	Supply air min regulator P-band setting.		
118	Supply air min C-factor.	0.000 - 2.500	PV 3.00
	Supply air min regulator affection setting.		
119	Supply air max P-band.	1.00 - 40.00	PV 3.00
	Supply air max regulator P-band setting.		
120	Supply air max C-factor.	0.000 - 2.500	PV 3.00
	Supply air max regulator affection setting.		
121	SA pre-filter alarm limit.	50-300Pa	PV 5.00
	Supply air pre-filter pressure alarm limit setting.		
122	EA pre-filter alarm limit.	50-300Pa	PV 5.00
	Extract air pre-filter pressure alarm limit setting.		
123	Xzone temperature reg. Neutral zone.	0.50-10.00°C	PV 5.00
	Xzone neutral zone setting before shift between heating and cooling.		
124	Xzone ERS 1 Diff.	1.00 - 7.00°C	PV 5.00
	Supply air temperature difference setting according to the diagram for Xzone ERS 1.		
125	Xzone ERS 1 Breakpoint.	12.00 - 26.00°C	PV 5.00

Analog Output (AO).32bit IEEE-standard floats (R/W).

N2 Idx	Name	Min/Max	Misc
	Breakpoint setting according to the diagram for Xzone ERS 1.		
126	Xzone ERS 2 Breakpoint X1.	10.00-38.00°C	PV 5.00
	Breakpoint X1 setting according to the diagram for Xzone ERS 2.		
127	Xzone ERS 2 Breakpoint Y1.	10.00-40.00°C	PV 5.00
	Breakpoint Y1 setting according to the diagram for Xzone ERS 2.		
128	Xzone ERS 2 Breakpoint X2.	11.00-39.00°C	PV 5.00
	Breakpoint X2 setting according to the diagram for Xzone ERS 2.		
129	Xzone ERS 2 Breakpoint Y2.	10.00-40.00°C	PV 5.00
	Breakpoint Y2 setting according to the diagram for Xzone ERS 2.		
130	Xzone ERS 2 Breakpoint X3.	12.00-40.00°C	PV 5.00
	Breakpoint X3 setting according to the diagram for Xzone ERS 2.		
131	Xzone ERS 2 Breakpoint Y3.	10.00-40.00°C	PV 5.00
	Breakpoint Y3 setting according to the diagram for Xzone ERS 2.		
132	Xzone SA Temperature setpoint.	10.00-40.00°C	PV 5.00
	Xzone supply air temperature setting, for supply air temp regulation mode.		
133	Xzone EA/Room Temperature setpoint.	10.00-30.00°C	PV 5.00
	Xzone extract air/room temperature setting, for extract air/room temp regulation mode.		
134	Xzone SA Min temp setpoint.	8.00-20.00°C	PV 5.00
	Xzone supply air min.setpoint during EA/room regulation mode.		
135	Xzone SA Max temp setpoint.	16.00-50.00°C	PV 5.00
	Xzone supply air max.setpoint during EA/room regulation mode.		
136	Pre-heating setpoint.	-30.00-30.00°C	PV 5.00
	Setting of pre-heating temperature setpoint.		
137	Xzone P-band.	1.00-40.00	PV 5.00
	Xzone regulator P-band setting.		
138	Xzone SA reheat C-factor.	0.000 - 2.500	PV 5.00
	Xzone supply air reheat regulator affection setting.		
139	Xzone SA cooling C-factor.	0.000 - 2.500	PV 5.00
	Xzone supply air cooling regulator affection setting.		
140	Xzone EA reheat C-factor.	0.000 - 2.500	PV 5.00
	Xzone extract air reheat regulator affection setting.		
141	Xzone EA cooling C-factor.	0.000 - 2.500	PV 5.00
	Xzone extract air cooling regulator affection setting.		
142	Xzone SA min P-band.	1.00 - 40.00	PV 5.00
	Xzone supply air min regulator P-band setting.		
143	Xzone SA min C-factor.	0.000 - 2.500	PV 5.00
	Xzone supply air min regulator affection setting.		
144	Xzone SA max P-band.	1.00 - 40.00	PV 5.00
	Xzone supply air max regulator P-band setting.		

Analog Output (AO).32bit IEEE-standard floats (R/W).

N2 Idx	Name	Min/Max	Misc
145	Xzone SA max C-factor. Xzone supply air min regulator affection setting.	0.000 - 2.500	PV 5.00
146	Pre-heat P-band. Pre-heat regulator P-band setting.	1.00 - 40.00	PV 5.00
147	Pre-heat C-factor. Pre-heat regulator affection setting.	0.000 - 2.500	PV 5.00
148	ReCO2 CO2 setpoint. Setting of ReCO2 CO2 setpoint.	0-100.00%	PV 5.00
149	ReCO2 min outdoor air. Setting of ReCO2 min outdoor air.	0-8200l/s	PV 5.00
150	ReCO2 min exhaust air. Setting of ReCO2 min exhaust air.	0-8200l/s	PV 5.00
151	ReCO2 CO2 P-band. ReCO2 CO2 regulator P-band setting.	1.00 - 100.00	PV 5.00
152	ReCO2 CO2 C-factor. ReCO2 CO2 regulator affection setting.	0.000 - 5.000	PV 5.00
153	ReCO2 CO2 flow C-factor. ReCO2 flow regulator affection setting.	0.000 - 5.000	PV 5.00
154	ReCO2 heating C-factor. ReCO2 heating regulator affection setting.	0.000 - 5.000	PV 5.00
155	ReCO2 cooling C-factor. ReCO2 heating regulator affection setting.	0.000 - 5.000	PV 5.00
156	AYC heat temp set. Setting of AYC heated water temperature setpoint.	10.00-80.00°C	PV 5.07
157	AYC heat P-band. AYC heat regulator P-band setting.	1.00 - 40.00	PV 5.07
158	AYC heat C-factor. AYC heat regulator affection setting.	0.000 - 2.500	PV 5.07
159	AYC cool P-band. AYC cool regulator P-band setting.	1.00 - 40.00	PV 5.07
160	AYC cool C-factor. AYC cool regulator affection setting.	0.000 - 2.500	PV 5.07
161	AYC heat out comp. X1. AYC outdoor compensation of heated water, outdoor temp X1 setting.	-40.00-40.00°C	PV 5.07
162	AYC heat out comp. Y1. AYC outdoor compensation of heated water, heated water temp Y1 setting.	10.00-80.00°C	PV 5.07
163	AYC heat out comp. X2. AYC outdoor compensation of heated water, outdoor temp X2 setting.	-40.00-40.00°C	PV 5.07
164	AYC heat out comp. Y2. AYC outdoor compensation of heated water, heated water temp Y2 setting.	10.00-80.00°C	PV 5.07
165	AYC heat out comp. X3. AYC outdoor compensation of heated water, outdoor temp X3 setting.	-40.00-40.00°C	PV 5.07
166	AYC heat out comp. Y3. AYC outdoor compensation of heated water, heated water temp Y3 setting.	10.00-80.00°C	PV 5.07

Analog Output (AO).32bit IEEE-standard floats (R/W).

N2 Idx	Name	Min/Max	Misc
167	AYC heat room comp. temp limit.	0.00-40.00°C	PV 5.07
	AYC room compensation of heated water, heated water temp limit setting.		
168	AYC heat room comp P-band.	1.00-10.00°C	PV 5.07
	AYC room compensation of heated water, heated water P-band setting.		
169	AYC heat night comp temp.	-10.00-10.00°C	PV 5.07
	AYC night compensation of heated water, heated water night setting.		
170	AYC heat pump on temp.	-40.00-40.00°C	PV 5.07
	AYC pump operation of heated water, outdoor temp start setting.		
171	AYC heat pump off temp.	-40.00-40.00°C	PV 5.07
	AYC pump operation of heated water, outdoor temp stop setting.		
172	AYC cool out comp. X1.	-40.00-40.00°C	PV 5.07
	AYC outdoor compensation of chilled water, outdoor temp X1 setting.		
173	AYC cool out comp. Y1.	10.00-80.00°C	PV 5.07
	AYC outdoor compensation of chilled water, chilled water temp Y1 setting.		
174	AYC cool out comp. X2.	-40.00-40.00°C	PV 5.07
	AYC outdoor compensation of chilled water, outdoor temp X2 setting.		
175	AYC cool out comp. Y2.	10.00-80.00°C	PV 5.07
	AYC outdoor compensation of chilled water, chilled water temp Y2 setting.		
176	AYC cool out comp. X3.	-40.00-40.00°C	PV 5.07
	AYC outdoor compensation of chilled water, outdoor temp X3 setting.		
177	AYC cool out comp. Y3.	10.00-80.00°C	PV 5.07
	AYC outdoor compensation of chilled water, chilled water temp Y3 setting.		
178	AYC cool room comp. temp limit.	0.00-40.00°C	PV 5.07
	AYC room compensation of chilled water, chilled water temp limit setting.		
179	AYC cool room comp. P-band.	1.00-10.00°C	PV 5.07
	AYC room compensation of chilled water, chilled water P-band setting.		
180	AYC cool night comp temp.	-10.00-10.00°C	PV 5.07
	AYC night compensation of chilled water, chilled water night setting.		
181	AYC cool pump on temp.	-40.00-40.00°C	PV 5.07
	AYC pump operation of chilled water, outdoor temp start setting.		
182	AYC cool pump off temp.	-40.00-40.00°C	PV 5.07
	AYC pump operation of chilled water, outdoor temp stop setting.		
183	Humid reg. Start.	10.00-90.00%	PV 5.10
	Humidifying start limit setting.		

Analog Output (AO).32bit IEEE-standard floats (R/W).

N2 Idx	Name	Min/Max	Misc
184	Humid reg. Stop.	15.00-95.00%	PV 5.10
	Humidifying stop limit setting.		

Binary Output (BO).1bit (R/W).

N2 Idx	Name	Min/Max	Misc
1	Alarm reset Resets tripped alarms.	0-1	
2	SA Boosting func. Setting for activating the boost function for the supply air fan.	0-1	
3	EA Boosting func. Setting for activating the boost function for the extract air fan.	0-1	
4	R.HX. Defrost func. Setting for activating the defrost function for the rotary heat exchanger.	0-1	
5	SA Down regulation func. Setting for activating the down regulation function for the supply air fan. (Moved to ADI 128 in PV 3.00)	0-1	PV 3.00
6	Reserve		
7	Reserve		
8	Cool operation mode Setting for cooling between off and auto operation.	0-1	
9	Int. Night heat func. Setting for activating the intermittent night heat function.	0-1	
10	Damper func. Setting for activating the damper output relay during int. night heat.	0-1	
11	Summer night cooling Setting for activating the summer night cool function.	0-1	
12	Temp displacement Setting for activating the external temperature displacement function.	0-1	
13	Outdoor temp compensation Setting for activating the outdoor temperature compensation function.	0-1	
14	Outdoor airflow compensation Setting for activating the outdoor airflow compensation function.	0-1	
15	Auto. Summer/winter switch Setting for activating the automatic switch between summer/winter time function.	0-1	
16	Switch clock func. Setting for switch clock function type. 0=Stop - low speed - high speed. 1=Low speed - high speed.	0-1	
17	Internal fire alarm func. Setting for activating the internal fire alarm function.	0-1	
18	EA at fire Setting for activating the extract air fan operation at fire function. (Moved to ADI 127 in PV 3.00)	0-1	PV 3.00
19	External alarm 1 active at closure Setting for external alarm number 1 condition to be activated. 0= alarm at closed input. 1= alarm at open input.	0-1	

Binary Output (BO).1bit (R/W).

N2 Idx	Name	Min/Max	Misc
20	External alarm 2 active at closure	0-1	
	Setting for external alarm number 2 condition to be activated. 0= alarm at closed input. 1= alarm at open input.		
21	Reserve		
22	Dewpoint reg. func.	0-1	
	Setting for activating the dewpoint regulator function.		
23	Dehumid reg. func.	0-1	
	Setting for activating the dehumid regulator function.		
24	External fire alarm func.	0-1	PV 3.00
	Setting for external fire resetting function. 0= Manual. 1= Automatic.		
25	External alarm 1 func.	0-1	PV 3.00
	Setting for external alarm 1 resetting function. 0= Manual. 1= Automatic.		
26	External alarm 2 func.	0-1	PV 3.00
	Setting for external alarm 2 resetting function. 0= Manual. 1= Automatic.		
27	Temperature alarm func.	0-1	PV 3.00
	Setting for activating temperature below setpoint alarm function (no.80).		
28	Int. Night heat output func.	0-1	PV 5.00
	Setting for selecting the intermittent night heat output function. 0=IQnomic 1=IQnomic+		
29	AYC heat out comp. func.	0-1	PV 5.07
	Setting for selecting the AYC outdoor comp. heated water function. 0=Inactive 1=Active		
30	AYC heat room comp. func.	0-1	PV 5.07
	Setting for selecting the AYC room comp. heated water function. 0=Inactive 1=Active		
31	AYC heat room comp. night block func.	0-1	PV 5.07
	Setting for selecting the AYC room comp. heated water night block function. 0=Inactive 1=Active		
32	AYC heat night comp. func.	0-1	PV 5.07
	Setting for selecting the AYC night comp. heated water function. 0=Inactive 1=Active		

Binary Output (BO).1bit (R/W).

N2 Idx	Name	Min/Max	Misc
33	AYC heat valve signal func.	0-1	PV 5.07
	Setting for selecting the AYC valve signal heated water alarm function. 0=Inactive 1=Active		
34	AYC cool out comp. func.	0-1	PV 5.07
	Setting for selecting the AYC outdoor comp. chilled water function. 0=Inactive 1=Active		
35	AYC cool room comp. func.	0-1	PV 5.07
	Setting for selecting the AYC room comp. chilled water function. 0=Inactive 1=Active		
36	AYC cool room comp. night block func.	0-1	PV 5.07
	Setting for selecting the AYC room comp. chilled water night block function. 0=Inactive 1=Active		
37	AYC cool night comp. func.	0-1	PV 5.07
	Setting for selecting the AYC night comp. chilled water function. 0=Inactive 1=Active		
38	AYC cool valve signal func.	0-1	PV 5.07
	Setting for selecting the AYC valve signal chilled water alarm function. 0=Inactive 1=Active		