

# INSTRUCTIONS FOR THE INSTALLATION OF THE TBTB-2 Roof for GOLD SD units Supply section TBTF-2/TBTA-3 Extract air hood TBTA-2

---

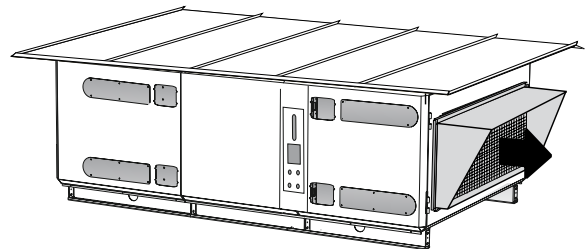
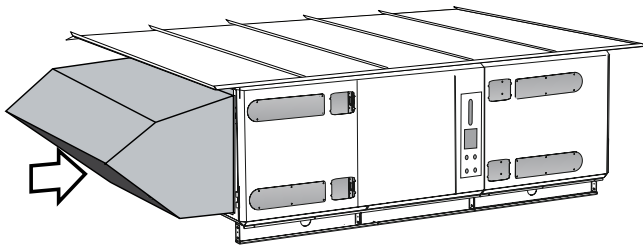

## 1. GENERAL

These instructions for installation supplement the assembly instructions that accompany the assembly parts.

**CAUTION!** Mount the roof before installing any electric wiring! When you have finished mounting the roof, install the electric wiring in an appropriate manner. Make sure that the cables do not block inspection doors and that the cable glands seal tightly against cables.

### 1.1 Where to install the unit

The GOLD air handling unit should be installed where it is most favourable weather-wise. It is especially important that rain or snow doesn't come into the unit through the intake section or the extract air hood.

The GOLD unit can be used for a right-hand or left-hand airflow arrangement. This flexibility can be utilised for locating the unit wherever it is most convenient.

### 1.2 Supply air and exhaust air ducts

Insulate the supply air and exhaust air ducting in accordance with applicable standards. If the ducts used are internally insulated, the TBLZ-1-65 countersinking kit should be used so that the measurement probe on the GOLD unit's supply air sensor will reach sufficiently far inside the duct.

### 1.3 Duct accessories

Select duct accessories housed in insulated casings if they are to be installed outdoors. These accessories can be installed outdoors; however the enclosure classes and permissible ambient temperatures of any actuators included must be taken into consideration. See the instructions for the corresponding accessory. If necessary, see to it that required protection is arranged.

### 1.4 Hand-held terminal

The hand-held terminal of the GOLD air handling unit is sensitive to cold and shall always be kept inside a heated space. If needed, connect the terminal to the air handling unit across one or several extension cables (TBLZ-1-05) and across an extension set (TBLZ-2-13) as well.

## 2. ROOF

The roof is supplied as a complete assembly kit.

### 3. Intake air section with pre-filter

#### 3.1 TBTF intake air section with pre-filter (sizes 04-40)

Secure the air intake section with screws against the end connection panel of the air handling unit using the tapped holes in the panel (full face = size 12) or not against the end connection adapter of the air handling unit (not full face = sizes 04/05, 08, 14/20, 25/30 and 35/40) with self-tapping screws.

The pre-filter should be replaced when the pressure drop across it has reached the estimated final pressure drop, however filter change is recommended at least once a year. For a correct estimate of the final pressure drop, we refer to our ProUnit air handling unit selection program. When replacing a filter, place the coloured side of the filter against the mesh and fasten it in position. When you refit the filter cassette into position in the intake air section, the side fitted with mesh must face the air handling unit.

#### To connect electric power to possible damper actuator

The electrical connections are to be wired by a qualified electrician in accordance with local electrical safety regulations.

Open the inspection cover of the intake air section.

The damper actuator is equipped with a connection cable and pre-fitted cable entry grommets.

**NOTE! Damper actuators are rated for various voltages. Therefore always check the type and rating of the damper actuator before wiring it to a power supply!**

#### Damper actuators with spring return

Used for operating shut-off dampers.

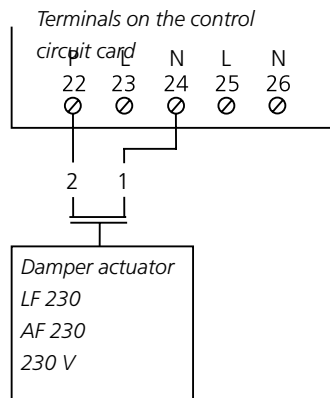

#### Damper actuators with modulated action

24 V supply voltage, on control circuit card wiring terminals 58-59 and 60-61. The max. permissible load on these terminals is 32 VA.

##### Option 1

The actuator should **not** close the damper if the air handling unit stops.

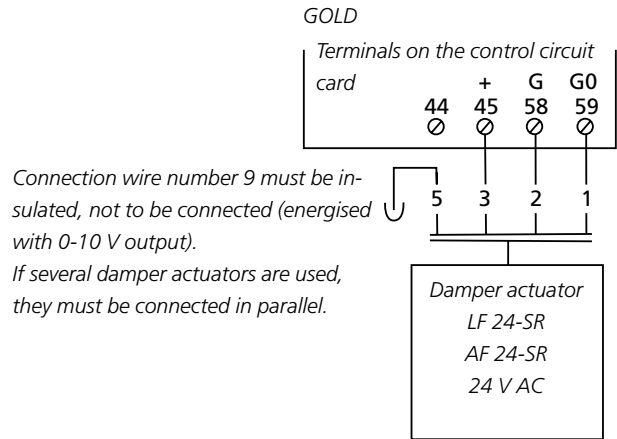

Under normal operating conditions, the damper opens and closes by means of the damper actuator's motor drive (actuating time: 90 seconds).

##### Option 2

The actuator should close the damper if the air handling unit stops.

If the damper actuator must close the damper when the air handling unit stops, then a 24 V supply voltage cable can be wired via the GOLD air handling unit's service contact.

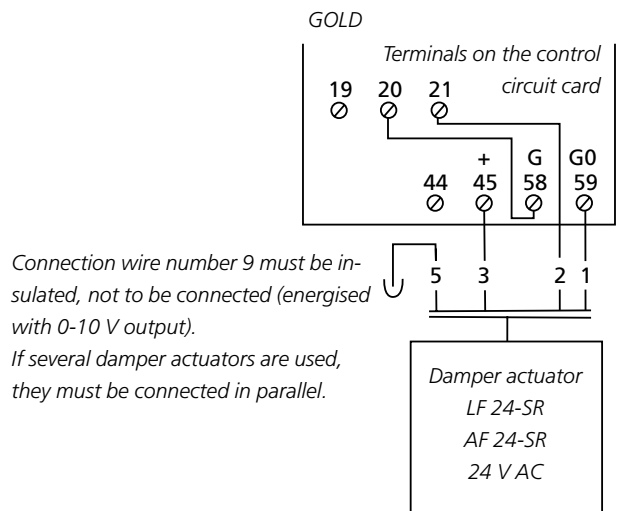

### **3.2 TBTA intake air section (sizes 50-120)**

Centre the air intake section in relation to the duct connection of the unit. Secure it to the end wall of the unit by means of max 45 mm long self-tapping screws (the screws are not included in the supply).

The air intake section has adequate space inside for fitting an air intake damper, if specified, to the duct connection.

## **4. EXTRACT AIR COWL**

Sizes 04-08: The extract air cowl is circular and is designed to be secured by means of screws to the duct connection of the air handling unit or in a duct having the same dimensions.

Sizes 12-120: The extract air cowl is rectangular and has a flange for slip-clamp jointing. The set of slip clamps is included in the supply.

The extract air cowl is designed to be secured by slip clamps to the duct connection of the air handling unit or to a duct having the same dimensions.

