

COOL DXS Cooling Unit

Installation and Maintenance Instructions

Sizes 12 – 80



Contents

1. OVERVIEW	3
1.1. General.....	3
1.2 Basic function diagram.....	4
1.3 Regulation	5
1.3.1 Cooling compressors	5
1.3.2 Condenser fans	5
2 SAFETY PRECAUTIONS	6
2.1 Safety Isolating Switch/Main Switch.....	6
2.2 Risks	6
2.3 Electrical equipment.....	6
2.4 Authority	6
2.5 Decals.....	6
3 INSTALLATION	7
3.1 Unloading/site transport.....	7
3.1.1 Handling with truck	7
3.1.2 Handling with crane	7
3.2 Arrangement	8
3.3 Installation principal	8
3.3.1 Duct connection	9
3.3.2 Drainage	9
4 Electrical connections.....	10
4.1 Power connection	10
4.2 Connection of communication cable	10
5 Commissioning.....	12
5.1 Preparations.....	12
5.1.1 Before initial start up	12
5.1.2 Starting up	12
5.1.3 Pressure sensor	12
5.1.4 Phase-sequence monitor.....	12
5.1.5 Action if the phase-sequence is wrong	12
6 Alarms.....	12
7 Maintenance.....	13
7.1 Cleaning	13
7.2 Handling of cooling medium	13
7.3 Periodic inspection	13
7.4 Service	13
8 Troubleshooting and leakage tracing.....	14
8.1 Troubleshooting Schedule	14
8.2 Leakage Tracing	14
9 Measurement	15
9.1 COOL DXS 12	15
9.2 COOL DXS 20 - 80	15
10 General technical data	16
11 Electrical equipment	16
12 Internal wiring diagram.....	17
12.1 Cool DXS size 12 all capacity variants, and size 20, capacity variant 1	17
12.2 COOL DXS size 20 capacity variant 2, size 30 all capacity variants and size 40 capacity variant 1	18
12.3 COOL DXS size 40 capacity variant 2 and size 60 capacity variant 1	19
12.4 COOL DXS size 60 capacity variant 2 and size 80 capacity variant 1	20
12.5 COOL DXS size 80 capacity variant 2	21
13 Commissioning Record	22

1. Overview

1.1. General

COOL DXS is a new cooling unit for comfort cooling, to be used together with Swegon's GOLD air handling unit.

The cooling unit is available in 12 capacity variants spread on nine physical sizes, designed for the size 12 - 80 GOLD air handling units.

The cooling unit should be placed outside.

The cooling unit should be connected to the supply air duct behind the GOLD air handling unit.

Mechanical design

All the components conform to refrigeration engineering standards and are pre-wired and collected inside a common casing.

The casing is composed of profiled frame members, cover panels and inspection covers. The outside is made of pre-painted (NCS 2005 Y 30R) galvanised sheet steel. The interior is made of aluminium-zinc treated sheet steel. The metal thickness is 1.5 mm. In the lower section, the cover panels and inspection covers are of a sandwich construction with intervening expanded polyurethane insulation (35 mm).

The diagonal air cooler is located in the lower section. A droplet separator with aluminium fins is available as accessory. Double condenser coils are located in the upper section. The condenser and cooling coils are fabricated of copper tubing and profiled aluminium fins; the casing is made of galvanized sheet steel.

In the upper section, there is an electrical equipment cubicle containing all electrical and control equipment.

All the equipment is easily accessible from the front or rear for servicing and inspections.

The cooling units are test run prior to delivery.

Cooling compressors

The cooling compressors are located in a separate space in front of the air cooler (seen from the inspection side). The sight glass and the expansion valve are also located here, where they are easily accessible for service.

The cooling compressors are totally hermetical of scroll-type.

The size 60 COOL DXS in capacity variant 2 and the size 80 in capacity variants 1 and 2 are equipped with three cooling compressors. All other sizes/capacity variants have two cooling compressors.

Completely direct-acting system

The cooling unit has a completely direct-acting system. It has an air cooler for direct-evaporative cooling refrigerant on the cold side and two condenser coils connected in parallel on the hot side.

Condenser fans

The cooling unit is equipped with 1-3 condenser fans of axial type on the hot side. Size 40 capacity variant 2 and up to size 80 capacity variant 1 have two condenser fans, size 80 capacity variant 2 has three condenser fans. All other sizes/capacity variants are equipped with one condenser fan.

Condenser fans suck air from the surroundings through the condenser coils and discharge it upwards.

Condenser fans are equipped with variable speed regulation.

Refrigerant

The cooling unit has one refrigerant circuit. Type R410A (HFC) refrigerant is used. The refrigerant circuit is charged with refrigerant on delivery. This type of refrigerant has no influence on the ozone layer.

Refrigerant volume

See section 10 General technical data.

Reporting obligation

The client/user is obligated to file a report with the local inspectorate if the total refrigeration volume is more than 10 kg.

Periodic inspection

If the volumetric weight of the refrigerant in the cooling unit is more than 3 kg, periodic inspection by an accredited inspectorate is required. Periodic checks should be carried out every sixth month for the COOL DXS size 60 units, capacity variants 1 and 2, and for the size 80 units, capacity variant 2. For other sizes and capacity variants periodic inspection should be carried out every twelve months.

Quality System to ISO 9001 and Environmental Management System to ISO 14001

Swegon AB is involved with a certified quality system that conforms to ISO 9001 standard and a certified Environmental Management System that conforms to ISO 14001.

1.2 Basic function diagram

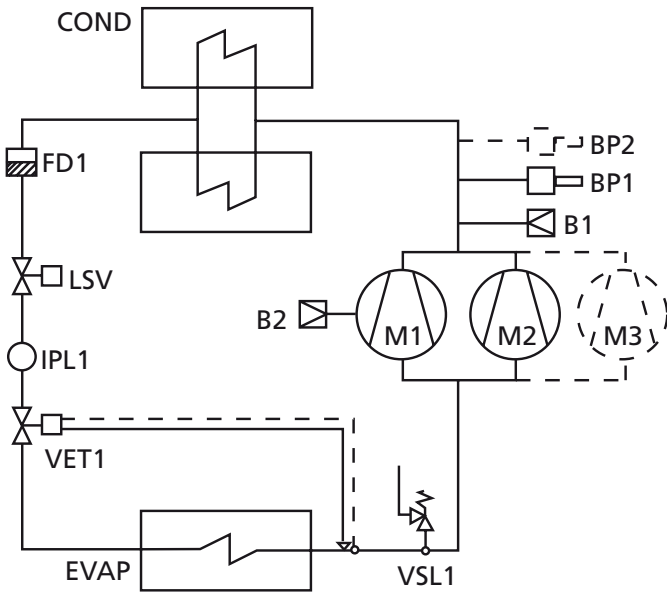

Operation

There is one refrigerant circuit in the cooling unit.

The refrigerant circuit is equipped with a fin type condenser, fin type evaporator and cooling compressor.

The gaseous refrigerant is compressed by cooling compressors M1 and M2 (in some units: M3) and from there flows to condenser COND, where it is cooled down by separate condenser flow and is condensed to liquid form.

The gaseous refrigerant flows through expansion valve VET1, where the pressure and the temperature decrease.

From the expansion valves, the refrigerant advances to evaporator EVAP, where the refrigerant evaporates and cools down the outside air.

The evaporated refrigerant flows from evaporator EVAP further to the suction side by the cooling compressors to once again be compressed.

Low/high pressure sensors B1/B2 measure the pressure of the system, in order for the control system to ensure that these are within stipulated limits.

Solenoid valve LSV ensures that the refrigerant remains in condenser coils when all compressors are idle.

COND	Condenser
BP1	High pressure switch
BP2	High pressure switch (size 60, capacity variant 2 and size 80, capacity variants 1 and 2 only).
B1	High pressure sensor
B2	Low pressure sensor
M1	Cooling compressor
M2	Cooling compressor
M3	Cooling compressor (size 60, capacity variant 2 and size 80, capacity variants 1 and 2 only)
VSL1	Overpressure protection, low pressure
EVAP	Evaporator
VET1	Thermostatic expansion valve with pressure equalization
IPL1	Sight glass
LSV	Solenoid valve
FD1	Drying filter

1.3 Regulation

1.3.1 Cooling compressors

The cooling compressors are controlled from the GOLD unit via relays on the IQnomic Plus module mounted in the cooling unit.

Size 12, capacity variant 1 to size 30, capacity variant 1

These sizes have two cooling compressors of the same size and are regulated in two steps. The cooling capacity is regulated 60-100% (equivalent airflows, temperatures, etc.).

Step 1: Cooling compressor 1 starts if there is a cooling load (the cooling compressor with the shortest operation time starts first and is called here cooling compressor 1).

Step 2: Cooling compressor 2 starts if further cooling is necessary and runs at the same time as cooling compressor 1. An adjustable time delay (a stepping duration of 300 seconds) ensures that cooling compressor 2 does not start until cooling compressor 1 operates at full capacity.

There is a time delay with subsequent down-step switching if the cooling load decreases. Cooling compressor 2 must have been in operation for at least 90 seconds before it can be stopped. The restarting time (300 seconds) for cooling compressor 1 shall have expired to enable it to start again in Step 1, after it has operated in Step 2.

Size 30 capacity variant 2 to size 60 capacity variant 1

These sizes have two cooling compressors of different size and are regulated in two binary steps. The cooling capacity is regulated 50-75-100% (equivalent airflows, temperatures, etc.).

Step 1: When cooling is needed, cooling compressor 1 is started.

Step 2: If more cooling is needed, cooling compressor 2 starts and at the same time cooling compressor 1 stops. An adjustable time delay (a step duration of 300 seconds) ensures that cooling compressor 2 will not start until cooling compressor 1 is operating at full capacity.

Step 3: Cooling compressor 1 is restarted if more cooling is necessary and is operated at the same time as cooling compressor 2. This third cooling step is also delayed by the preset time delay setting. Besides this, the restart time (300 seconds) for cooling compressor 1 must have expired.

There is a time delay with subsequent down-step switching if the cooling load decreases. Cooling compressor 2 must have been in operation for at least 90 seconds before it can be stopped. The restarting time (300 seconds) for cooling compressor 1 shall have expired to enable it to start again in Step 1, after it has been operated in Step 3.

Size 60 capacity variant 2 to size 80 capacity variant 2

These sizes have three cooling compressors of the same size and are regulated in three steps. The cooling capacity is regulated 50-75-100% (equivalent airflows, temperatures, etc.).

Step 1: Cooling compressor 1 starts if there is a cooling load (the cooling compressor with the shortest operating time starts first and is here called cooling compressor 1).

Step 2: Cooling compressor 2 starts if more cooling is necessary and runs at the same time as cooling compressor 1. Adjustable time delay (stepping duration of 300 seconds) ensures that cooling compressor 2 does not start until cooling compressor 1 is operating at full capacity.

Step 3: Cooling compressor 3 starts if more cooling is necessary and runs at the same time as cooling compressors 1 and 2. An adjustable time delay (step time 300 seconds) ensures that cooling compressor 3 does not start until cooling compressors 1 and 2 are operating at full capacity.

There is a time delay with subsequent down-step switching if the cooling load decreases. Cooling compressors 2 and 3 must have been in operation for at least 90 seconds before they can be stopped. The restarting time (300 seconds) for cooling compressor 1 and 2 shall have expired to enable them to start again in step 1 or step 2, after they have been operated in Step 3.

All sizes

If any cooling compressor stops, the restarting time must expire before a restart can take place. The restart time is calculated from one start to the next start.

If the pressure in cooling circuit becomes too low or if the pressure in condenser circuit becomes too high, the cooling capacity is decreased by stopping the compressors in steps until the pressure is stabilised. The text COOLING PRESSURE LIMITATION is then alternately displayed in the hand-held terminal of the air handling unit. When the restart time has expired, the cooling compressor will try to restart.

If the pressure decreases or increases further, alarm 160 (COOL DXS low pressure below alarm limit) and 161 respectively (COOL DXS high pressure above alarm limit), trip and the compressors are stopped.

For reasons of safety, there is also a high pressure switch BP1/2 which interlocks the start signal to the compressors.

Pressure switch BP1/2 can be manually reset by pressing a button under each protective sock on the upper side of the pressure switch. This can be done without removing the protective sock.

1.3.2 Condenser fans

The speed of the condenser fan(s) increase(s) steplessly to limit the pressure level when the high pressure in the refrigerant circuit exceeds the limit value.

2 Safety precautions

2.1 Safety Isolating Switch/Main Switch

The safety isolating switch is placed on the door of the electric cubicle. The electric cubicle is located inside the upper inspection cover on the inspection side of the cooling unit (decal is affixed on current inspection cover).

The safety switch should not be used for start or stop of the cooling unit.

Ensure that the cooling unit is shut off by stopping the air handling unit or by temporarily shutting off the cooling unit via the hand-held micro terminal, see the GOLD operation and maintenance instructions.

When this has been carried out, the current can be isolated with the safety switch. For easy access to the safety switch, open the relevant inspection cover by unscrewing the knobs in the lower edge of the cover. Take hold of the cover in the handle and pull the cover carefully outwards.

N.B.! Have a good grip on the cover so that it will not fall down!

Important
Always switch off the safety isolating switch before servicing the unit if not otherwise specified in the pertinent instructions.

2.2 Risks

 Warning
Before carrying out any work, make sure that the power supply to the air handling unit has been switched off.

 Warning
Under no circumstances shall the refrigerant circuit be opened by unauthorised personal, since there is gas under high pressure in the circuit.

Risk areas with refrigerant

Risk area for refrigerant is in principal inside the entire cooling unit. For handling when leakage, see section 7.2 Handling of refrigerant.

Refrigerant used is R 410A.

 Warning
The upper inspection cover on the backside of the unit must not be opened while the cooling unit is in operation, since it functions as protective screen for condenser fans.
The lower cover panel on the backside of the cooling unit may not be dismantled when the air handling unit and/or the cooling unit is operating. The cover panel is likely to flip open and injure personnel.

2.3 Electrical equipment

The electrical equipment of the cooling unit is mounted in a separate electrical cubicle inside the upper inspection cover on the inspection side of the cooling unit. For easy access to the electrical equipment, open the inspection cover by unscrewing the knobs in the lower edge of the cover. Take hold of the cover by the handle and pull the cover carefully outwards.

N.B.! Have a good grip on the cover so that it will not fall down!

2.4 Authorisation

Only authorized electricians shall be permitted to install electrical wiring in the cooling unit.

Servicing inside or reparation of the refrigerant circuit may only be performed by technicians of an accredited cooling firm.

Other service work in the cooling unit should only be performed by service personnel trained by Swegon.

2.5 Decals

The type number mark with type designation, serial number, refrigerant volume and more is affixed on the inspection side of the cooling unit.

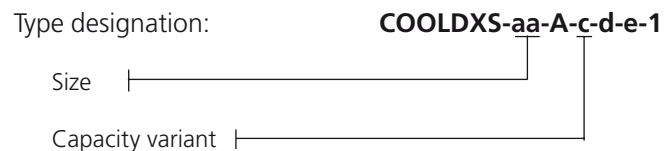

3 Installation

3.1 Unloading/site transport

Important

All transport should take place with the cooling unit in horizontal position.

3.1.1 Handling with truck

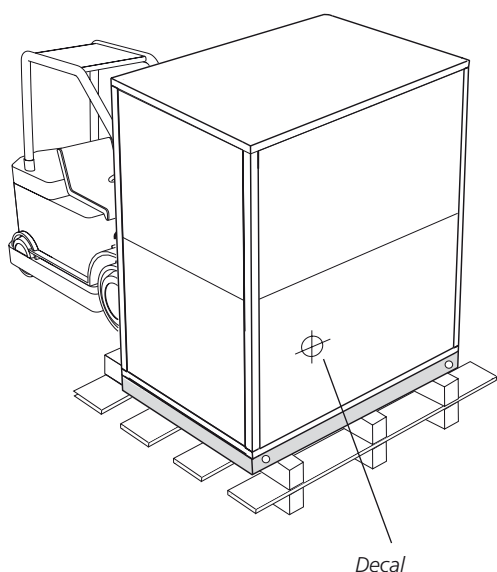

Warning

The cooling unit's centre of gravity is not centralised. The decal showing the centre of gravity is placed on the packaging of the cooling unit when delivered, see drawing above.

Regard to the centre of gravity should be taken when lifting the cooling unit!

3.1.2 Handling with crane

Place two sling spreaders on the upper side of the cooling unit. Place the two supplied lifting pipes in therefore intended holes on the bottom beam, see drawing.

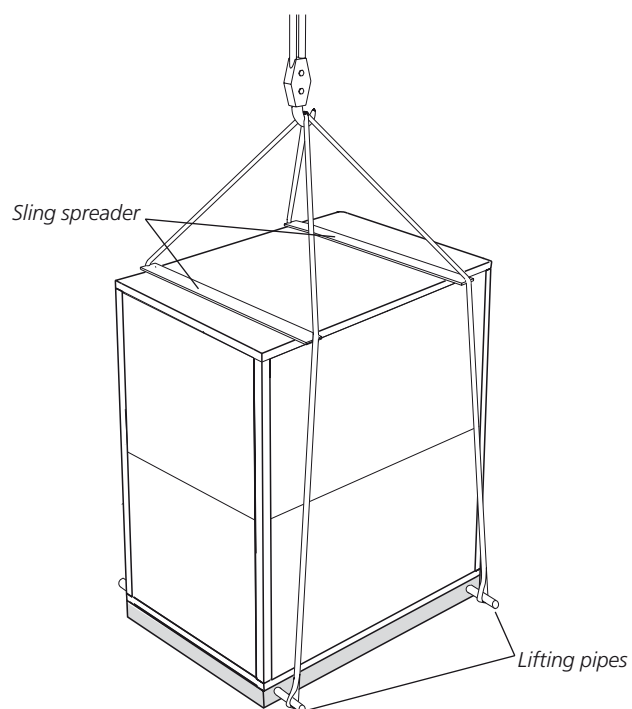

3.2 Arrangement

The cooling unit should be placed outdoors (extra accessories are not necessary). The GOLD unit can also be placed outdoors with accessories for outdoor installation. It is also possible to install the GOLD unit indoors and simply route the supply air duct out to the cooling unit.

The required free distance for servicing by the inspection side and back side of the cooling unit is 1000 mm. Required free distance for airflow through condenser coils in the upper level of the cooling unit is 1500 mm. The space above the cooling unit should be completely free. See illustration.

Illustrations on this page show the right-hand version; the cooling unit is also in the left-hand version.

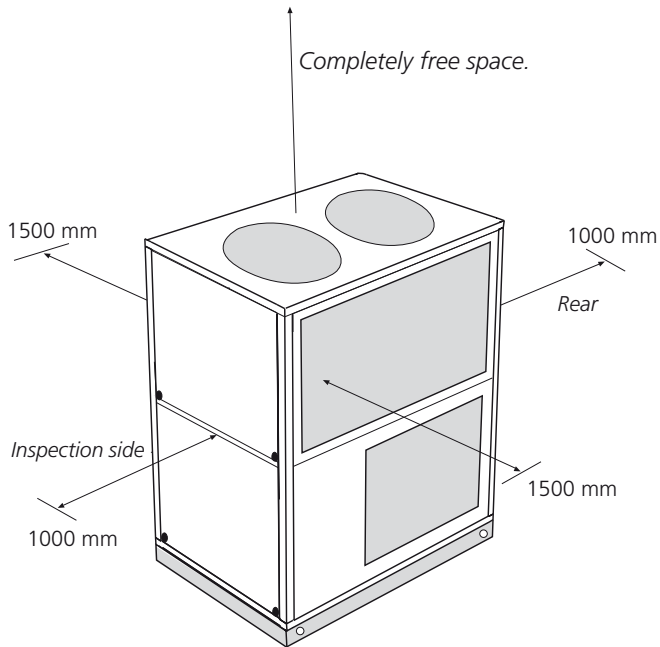

3.3 Basic installation principle

The cooling unit is connected to the supply air duct of the air handling unit, see drawing. The airflow through the bottom section of the cooling unit should be as indicated by the arrow affixed on the side of the cooling unit.

The dimensions and capacity of the cooling unit is matched for connection to the GOLD air handling unit in sizes 12 - 80.

For a list of the capacity sizes of cooling units matched to respective unit size, see Section 10 General technical data.

**GOLD RX/PX/CX,
supply air duct in lower level**

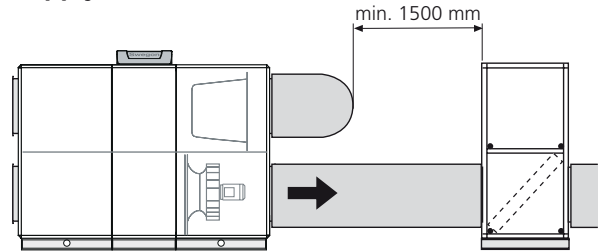

**GOLD RX/CX,
supply air duct in upper level**

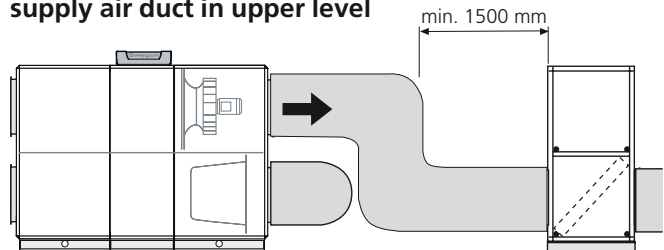

**GOLD SD,
supply air unit**

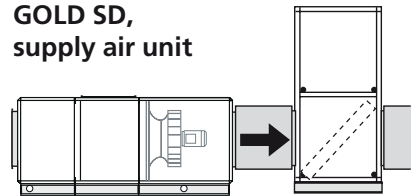

Supply air

3.3.1 Duct connection

Size 12

The size 12 COOL DXS cooling unit is equipped with rubber gaskets for the connection of a circular duct, \varnothing 500 mm (duct is not included in the delivery).

The ducts should be insulated according to local regulations and customary trade standards.

Sizes 20 – 80

The size 20-80 Cool DXS cooling unit has rectangular connection. Use slip clamps (accessories: TBXZ-2-aa-08 slip clamps) for jointing to ducts.

The ducts should be insulated according to local regulations and customary trade standards.

3.3.2 Drainage

On the rear of the cooling unit there is a drainage pipe (DN25) for condensate.

If necessary the drainage pipe should be connected to drain gully.

4 Electrical connections

Important

Installation must be carried out by a authorised electrician.

4.1 Power connection

The 400 V incoming power supply to the COOL DXS size 12, capacity variants 1 and 2 and size 20, capacity variant 1 should be a 5-wire system (3 phases, zero and earth).

The 400 V incoming power supply to the COOL DXS size 20, capacity variant 2 and up to size 80, capacity variant 2 should be 4-wire system (3 phases and earth).

The cross sectional dimension of the power supply cable should take into consideration the ambient temperature and way the cable is run.

Both inspection covers on the inspection side of the cooling unit can be opened by unscrewing the knobs at the bottom edge of the covers. Take hold of the cover in the handle and pull the cover carefully outwards. N.B.! Have a good grip of the cover so that it will not fall down!

Open the inspection door of the electric cubicle.

Pull the incoming cable for power supply through the cable gland in the cover panel of the cooling unit, through the space for compressors and through the cable gland of the electrical equipment cubicle, see drawing. Locate the cable in a safe way. Make sure that the cable does not touch compressors or other components, since surfaces could be hot or vibrate.

Connect the incoming power supply to the safety switch block situated in the cubicle, see drawing. The terminal for incoming earth is situated right next to the safety switch.

See section 10 Technical data.

4.2 To connect the communication cable

Only one communication cable is required for the transmission of information between the cooling unit and the air handling unit. All operation status and other information are readily available for viewing in the hand-held micro terminal of the GOLD air handling unit.

Communication cable is connected in the electrical equipment of the cooling unit and lays coiled behind the inspection cover in the space for compressors. Insert the communication cable and pull it through a predrilled hole in the cover panel, see drawing. Supplied rubber sleeve is installed in the predrilled hole. Run the cable in a secure manner from the cooling unit to the air handling unit. Also place the cable in a secure manner inside the cooling unit. Make sure that the cable does not touch compressors or other components, since surfaces could be hot or vibrate.

N.B.! If the communication cable and the power cable are run in parallel, they should be at least 100 mm from one another along the entire stretch.

The drawing displays COOL DXS from the inspection side with the inspection covers removed.

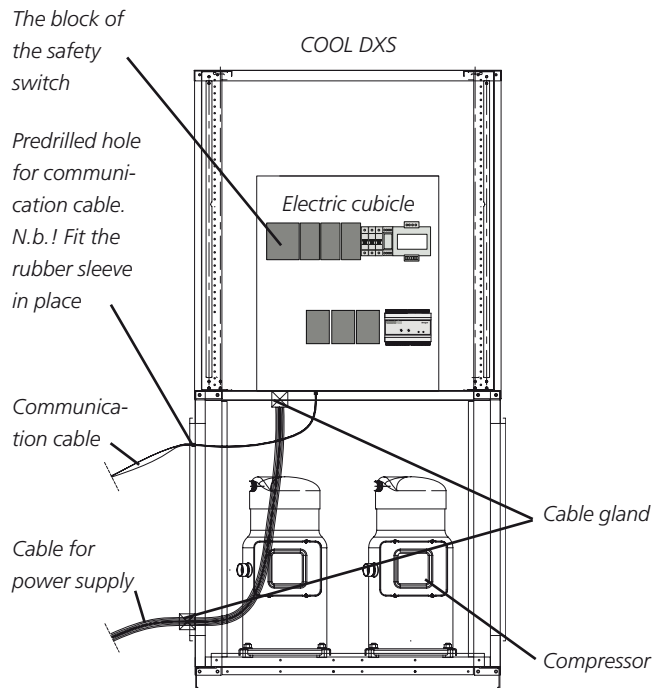

Installation of the GOLD air handling unit

Communication cable should be connected to any of the bus outlets on the control unit of the air handling unit, see encircled area on drawing.

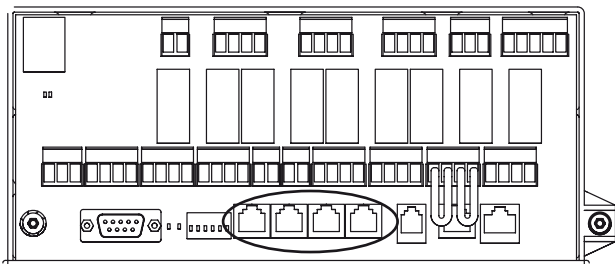

Use one of the holes in the oblong rubber coated cable gland, placed on the rear of the connection hood of the electric cubicle or on the inspection side of the air handling unit, in order to run a cable into control unit, see drawing.



Move part of the cable gland to the side in order to be able to pull the communication cable through. Connect the cable to an optional bus connection on control unit. Adjust the cable length inside electrical cubicle and fit the cable to seat properly in the lead-through. Then refit the lead-through to sit correctly.

5 Commissioning

5.1 Preparations

5.1.1 Before initial start up

- The power supply should be connected.
- The communication cable to the GOLD air handling unit should be connected to one of the connections marked Internal EIA-485.
- Check that all the safety switches and motor protection switches are set to ON.

The control system of the air handling unit has a pre-programmed factory setting, which makes the cooling unit ready for operation when the basic settings have been performed. The function for the cooling unit should be activated, see the Operation and Maintenance Instructions of the GOLD for particulars on how to handle the menus in the hand-held terminal

5.1.2 Starting up

- Set the safety isolating switch of the cooling unit to ON.
- Check the phase sequence, see Section 5.1.4.
- Check that light-emitting diode L2 on the IQnomic Plus module steadily shines (24 V supply), and that light-emitting diode L1 is flashing (communication). The function switch should be in the position given in table below section 13 Commissioning Protocol.
- Check in the hand-held micro terminal of the GOLD unit that Auto Operation has been selected as the air handling unit's cooling function (under Operation Mode), and that Cool DXS has been selected under Cooling Regulation.
- Enter the manual test menu via the hand-held terminal of the air handling unit, see the Operation and Maintenance Instructions of the GOLD.
- Check: First start the fan, then start one cooling compressor at the time, if any cooling compressor does not start, an alarm will be initiated.
- Set the cooling compressors to 0 (stop).
- Go back to the main menu.
- The cooling unit is now ready for operation and will start when there is a cooling load.

5.1.3 Pressure sensor

The cooling unit has two in-service pressure switches in each cooling circuit, one for low pressure and one for high pressure.

The compressor is stopped or stepped down when the operation pressure is outside of the limit values. The text COOL PRESSURE LIMITING is displayed in the hand-held terminal until the pressure again comes within limit values. The compressor is permitted to restart when the restart delay has expired.

5.1.4 Phase-sequence monitor

The cooling unit is equipped with phase sequence monitor to ensure that the compressors are rotating in the correct direction.

The phase sequence monitor is installed in the electrical equipment cubicle, see drawing.

Alarm 164-166, COOL DXS K1-3 tripped, is displayed in the hand-held terminal of the air handling unit. The alarms may be due to several causes: incorrect phase sequence, tripped high pressure switch (BP2) or the absence of control voltage.

Electrical equipment in the COOL DXS

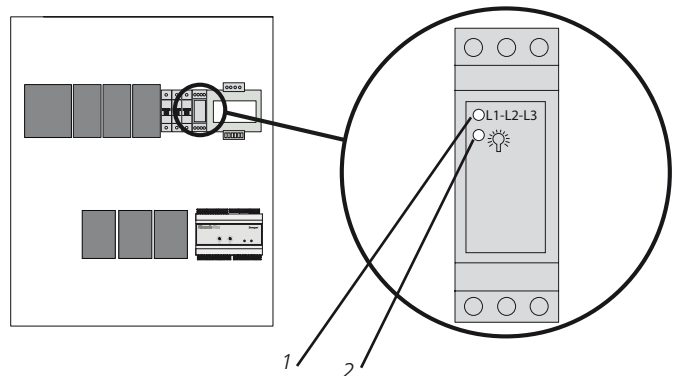

The phase sequence is correct when LED 1 is lit.
The voltage is connected when LED 2 is lit.

5.1.5 Measure whether the phase-sequence is wrong

 Warning
May only be performed by authorised or trained service personnel.

- Stop the cooling unit by selecting SHUT OFF in the menu SETTINGS.
- Set the safety switch to position OFF on the cooling unit.
- Isolate the power supply to the cooling unit.

Important
Check that the incoming power supply to the CoolDX is isolated by measuring.

- Transpose the two phase wires on the incoming power supply cable in order to obtain correct phase sequence (direction of rotation).
- Connect the power supply to the cooling unit.
- Set the safety switch to ON.
- Start the cooling unit as described in the section dealing with starting up, see Section 5.1.2 Starting up.

6 Alarms

For a description of the alarms, see the Operation and Maintenance Instructions for the GOLD.

7 Maintenance

7.1 Cleaning

Warning
Before covers are opened, see section 2, Safety instructions.

Inspect the cooling unit twice a year and clean if necessary. You should inspect it more often if it operates in a polluted environment.

It may be sufficient to carefully brush the condenser coils clean working from the outside, if there is lighter pollution.

The cover panel on the cooling unit's rear can be dismantled by loosening screws, if there is worse pollution. Lift away the cover panel. The inspection covers of the unit can be opened by unscrewing the knobs in at the bottom edge of the cover. Take hold of the cover in the handle and pull the cover carefully outwards. N.B.! Have a good grip of the cover so that it will not fall down!

If needed, clean the inside cleaning of the unit by vacuum cleaning and wiping surfaces with a damp cloth.

Condenser coils/air cooler can be cleaned as follows:

Clean the condenser coils only by carefully blowing with compressed air, vacuum cleaning with a soft nozzle or wet cleaning with water and/or solvent.

If cleaning solvent is used, do not use solvent that will corrode aluminium or copper. Swegon's cleaning agent is recommended. This cleaning agent is sold by Swegon Service.

Check in connection with cleaning that the drain pipe of the air cooler is not clogged.

7.2 Handling of refrigerant

The refrigerant used is R 410A.

The refrigerant circuit is completely charged when the unit is delivered. No further filling is necessary under normal conditions.

Warning
Under no circumstances may the refrigerant circuit be opened by unauthorised personnel, since it contains gas under high pressure. Only an accredited refrigeration company shall be permitted to modify or repair the refrigeration circuit.
The cooling unit is equipped with a safety valve to prevent excessively high pressure in the system if the temperature is high.

Important
Contact Swegon Service in the event of leakage of refrigerant.

Warning
If refrigerant is exposed to fire or in some other way becomes superheated in the atmosphere, poisonous gases can form.

Important
Filling of refrigerant must be performed in accordance with the recommendations of the refrigerant manufacturer.
Direct contact on skin should be avoided with refrigerant.
Use tightly sitting protective glasses, protective gloves and covering work clothes.
In the event of eye contact
rinse the eyes using an eye-wash shower (alternating with lukewarm water) for 20 minutes. Seek a doctor.
In the event of contact with skin
carefully wash with soap and lukewarm water.
In the event of frostbite
seek a doctor.

7.3 Periodic inspection

Periodic inspection by an accredited cooling firm is required, if refrigerant volume in the cooling unit is more than 3 kg. A periodic inspection should be carried out every sixth month for COOL DXS size 60, capacity variant 1 and 2, and for size 80, capacity variant 2. For other sizes and capacity variants, a periodic inspection should be carried out every twelfth month.

Obligation to report

You are obligated to file a report with the local supervisory authorities only if the total volume of refrigerant charged in refrigerating units at a given company exceeds 10 kg.

7.4 Service

Only service personnel trained by Swegon should be permitted to modify the cooling unit.

8 Trouble shooting and leakage tracing

8.1 Troubleshooting Schedule

Symptom	Possible cause	Remedial measure
Compressor is not operating	The voltage has been isolated. Incorrect phase sequence. The compressor safety circuit has been broken. Defective cooling compressor.	Check the operating/safety switch. Check the condition of the fuses. Check and change the phase sequence. Check, reset if needed. Replace the compressor.
Too low cooling capacity	The voltage has been isolated. Incorrect phase sequence. No airflow or too low airflow across the evaporator. Thermostat/control equipment incorrectly set or defective.	Check the operating/safety switch. Check the condition of the fuses. Check and change the phase sequence. Check the airflow. Adjust the setting or replace faulty components.
The low pressure switch is switching off the cooling compressor	Inadequate refrigerant. No airflow or too low airflow across the evaporator. Defective evaporator The expansion valve is defective. The high pressure switch is defective.	The cooling system is leaking. Tighten the leak and charge with refrigerant. Check the airflow. Check, replace. Check, replace. Check, replace.
The high pressure switch is switching off the cooling compressor	No airflow or too low airflow across the condenser. Excessively high ambient air temperature The high pressure switch is defective.	Check the airflow (condenser coil and fan). Check the ambient air temperature. Check, replace.
Significant freezing on the evaporator.	The expansion valve is defective or incorrectly set. No airflow or too low airflow across the evaporator. Defective air cooler	Check. Replace or adjust setting. Check the airflow. Check, replace.

8.2 Leakage Tracing

Leakage tracing should be carried out at least once per year as a precaution. The leakage tracing inspection must be documented.

If the cooling system is leaking, this will become apparent firstly by impaired cooling performance, or if the leakage is substantial, when the cooling unit does not operate at all.

If you suspect that the cooling system is leaking refrigerant, check the level of refrigerant in the sight glass located on the liquid line of the cooling unit.

If you see continuous and a substantial amount of bubbling in the sight glass and the cooling unit operates at appreciably lower capacity than normal, the system is probably leaking. One or several bubbles appearing when the cooling unit is started up, operation at reduced capacity or normal operation need not necessarily indicate a refrigerant deficiency.

If it is bubbling in the sight glass and the cooling unit operates at appreciably lower capacity, call for qualified service help.

N.B.! Maintenance work in the refrigerant system is permitted to be carried out only by an accredited inspectorate (a company with requisite authorisation).

9 Measurement

9.1 COOL DXS 12

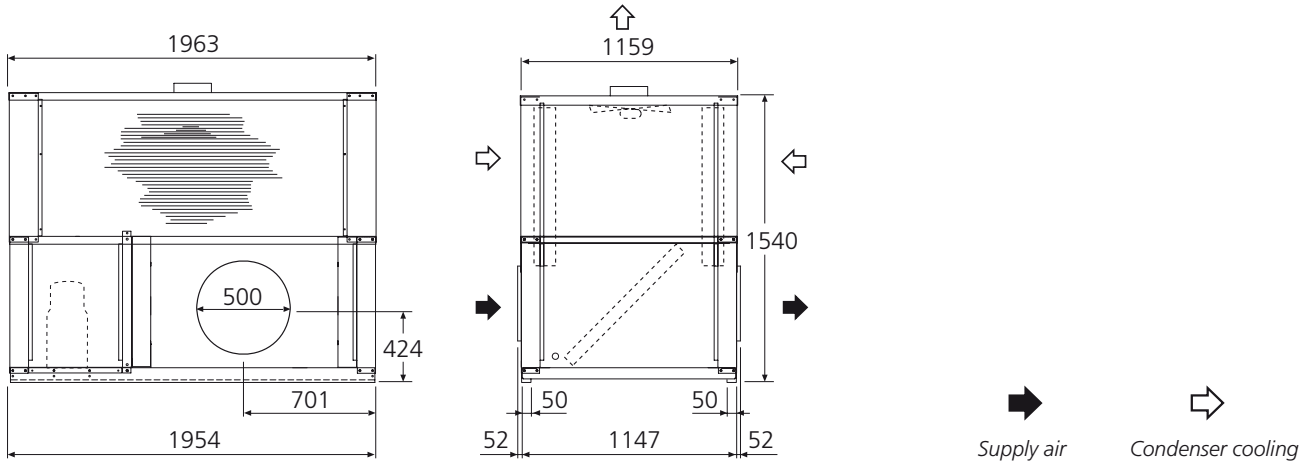

Weight:
 Capacity variant 1, 499 kg
 Capacity variant 2, 530 kg

9.2 COOL DXS 20 - 80

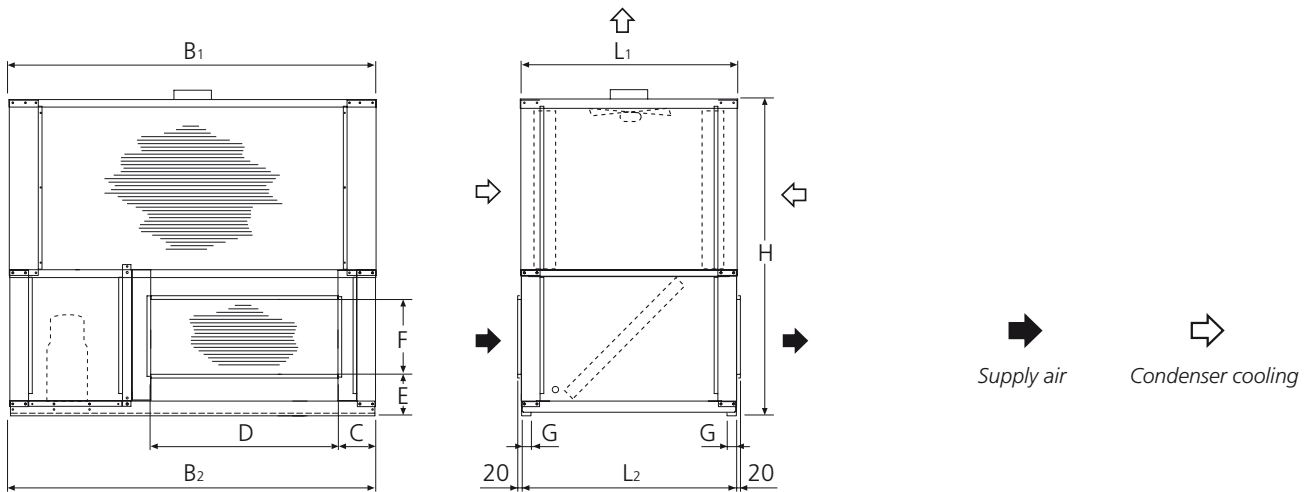

Size	Capacity variant	B1 mm	B2 mm	L1 mm	L2 mm	H mm	C mm	D mm	E mm	F mm	G mm	Weight kg
20	1	1963	1954	1159	1147	1540	201	1000	222	400	50	528
20	2	1963	1954	1159	1147	1690	201	1000	222	400	50	605
30	1	2163	2154	1159	1147	1811	201	1200	250	500	50	653
30	2	2163	2154	1159	1147	1811	201	1200	250	500	50	692
40	1	2413	2404	1159	1147	1999	226	1400	294	600	50	742
40	2	2413	2404	1159	1147	2299	226	1400	294	600	50	910
60	1	2861	2852	1159	1147	2350	350	1600	220	800	50	974
60	2	3308	3298	1159	1147	2350	350	1600	220	800	50	1260
80	1	3756	3747	1159	1147	2599	465	1800	257	1000	70	1364
80	2	3756	3747	1159	1147	2599	465	1800	257	1000	70	1462

10 General technical data

The data information is intended as an overview, exact values can be obtained through computer-assisted calculation.

Size	Capacity variant	Rated cooling power* kW	Min. airflow m ³ /h (m ³ /s)	Nominal airflow m ³ /h (m ³ /s)	Max. airflow m ³ /h (m ³ /s)	Power supply	Refrigerant charge kg	EER* (energy efficiency ratio)
12	1	18.5	2 520 (0.7)	3 960 (1.1)	6 840 (1.9)	3-phase, 400V+N+PE, 25A	3.9	2.9
12	2	28.5	2 880 (0.8)	3 960 (1.1)	6 840 (1.9)	3-phase, 400V+N+PE, 32A	6.1	3.1
20	1	29	2 880 (0.8)	6 120 (1.7)	9 720 (2.7)	3-phase, 400V+N+PE, 32A	6.1	3.2
20	2	43	3 600 (1.0)	6 120 (1.7)	9 720 (2.7)	3-phase, 400V +PE, 40A	9.0	3.1
30	1	44	4 320 (1.2)	9 000 (2.5)	13 680 (3.8)	3-phase, 400V+PE, 40A	9.5	3.0
30	2	62	3 600 (1.0)	9 000 (2.5)	13 680 (3.8)	3-phase, 400V+PE, 50A	11.0	3.1
40	1	61	3 960 (1.1)	12 600 (3.5)	19 080 (5.3)	3-phase, 400V+PE, 50A	12.4	3.0
40	2	89	4 680 (1.3)	12 600 (3.5)	19 080 (5.3)	3-phase, 400V+PE, 80A	18.3	3.1
60	1	88	5 400 (1.5)	18 000 (5.0)	26 280 (7.3)	3-phase, 400V+PE, 80A	18.3	3.0
60	2	129	6 840 (1.9)	18 000 (5.0)	26 280 (7.3)	3-phase, 400V+PE, 110A	30.6	3.0
80	1	127	8 280 (2.3)	25 200 (7.0)	37 080 (10.3)	3-phase, 400V+PE, 110A	30.6	3.0
80	2	179	9 720 (2.7)	25 200 (7.0)	37 080 (10.3)	3-phase, 400V+PE, 145A	42.2	3.1

* Ambient temperature 35 °C, inlet air temperature in cooling unit 27 °C (capacity variant 1) and 29 °C respectively (capacity variant 2) for nominal airflow.

Sizing

There are many factors that influence what size of cooling unit is required.

The cooling unit is designed to handle very different prerequisites.

For correct sizing we refer to our ProUnit air handling unit selection program.

11 Electrical equipment

The electrical equipment in the cooling unit is located inside the inspection cover.

For schematic description, see drawing.

All sizes and capacity variants

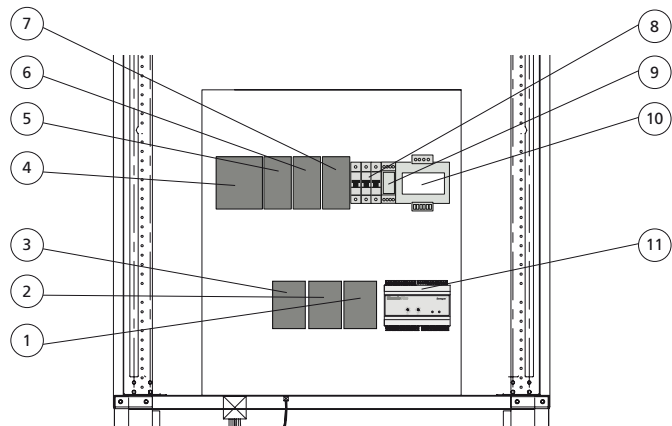

1. Contactor with auxiliary contact for possible cooling compressor 3.
2. Contactor with auxiliary contact for cooling compressor 2.
3. Contactor with auxiliary contact for cooling compressor 1.
4. Safety switch block.
5. Protective motor switch with auxiliary contact for cooling compressor 1.
6. Protective motor switch with auxiliary contact for cooling compressor 2.
7. Protective motor switch with auxiliary contact for possible cooling compressor 3.
8. Control circuit fuse.
9. Phase sequence monitor.
10. Transformer, if required, 400/230 V for control voltage.
11. IQnomic Plus, control unit.

12 Internal wiring diagram

12.1 Cool DXS size 12 all capacity variants, and size 20, capacity variant 1

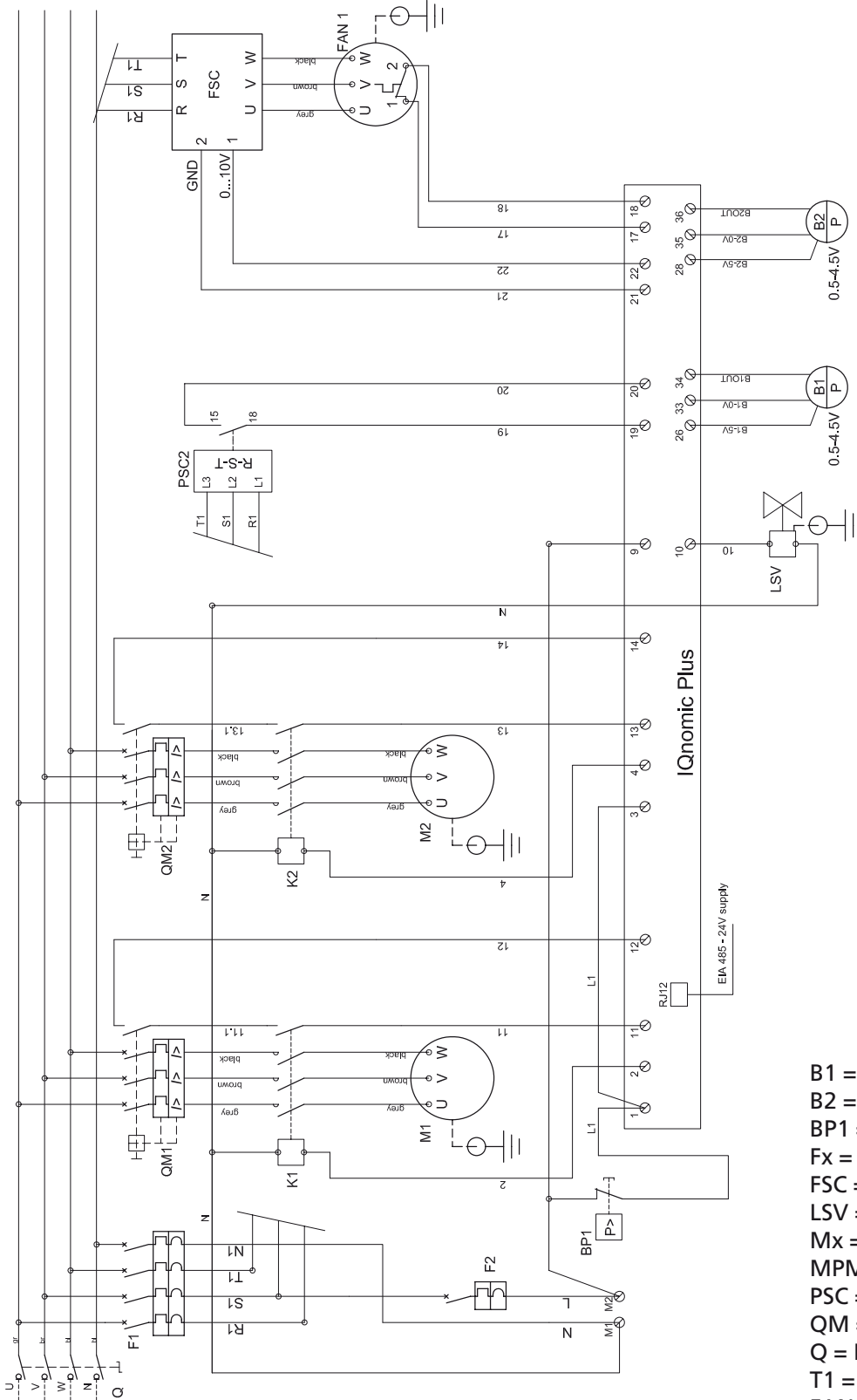

- B1 = High pressure switch
- B2 = Low pressure switch
- BP1 = High pressure switch
- Fx = Fuse
- FSC = Control, fan speed
- LSV = Solenoid valve
- Mx = Cooling compressor
- MPM = Module, motor protection
- PSC = Control, phase sequence
- QM = Motor protection
- Q = Load separator
- T1 = Transformer
- FAN = Fan

12.2 COOL DXS size 20 capacity variant 2, size 30 all capacity variants and size 40 capacity variant 1

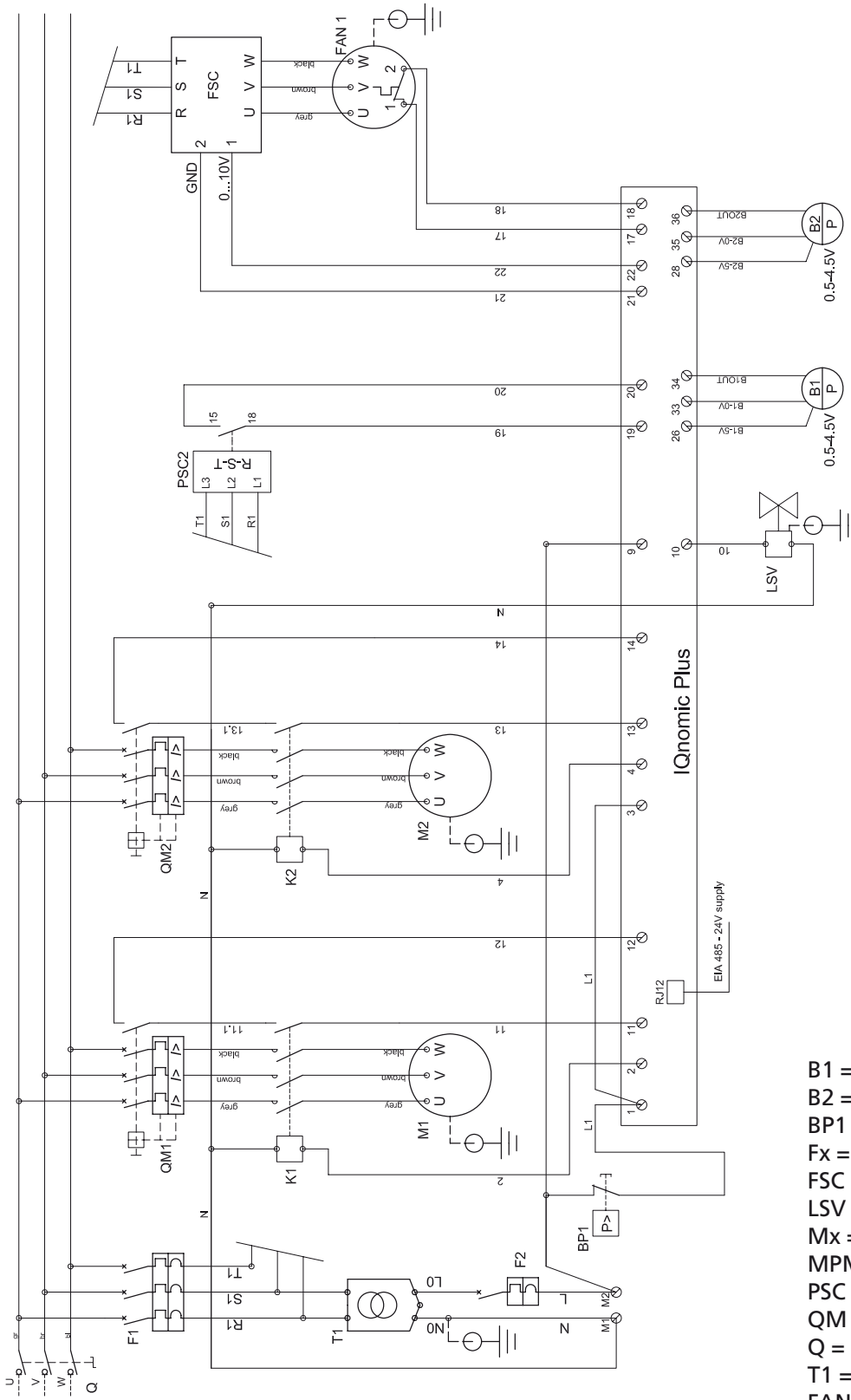

- B1 = High pressure sensor
- B2 = Low pressure sensor
- BP1 = High pressure switch
- Fx = Fuse
- FSC = Control, fan speed
- LSV = Solenoid valve.
- Mx = Cooling compressor
- MPM = Module, motor protection
- PSC = Control, phase sequence
- QM = Motor protection
- Q = Load separator
- T1 = Transformer
- FAN = Fan

12.3 COOL DXS size 40 capacity variant 2 and size 60 capacity variant 1

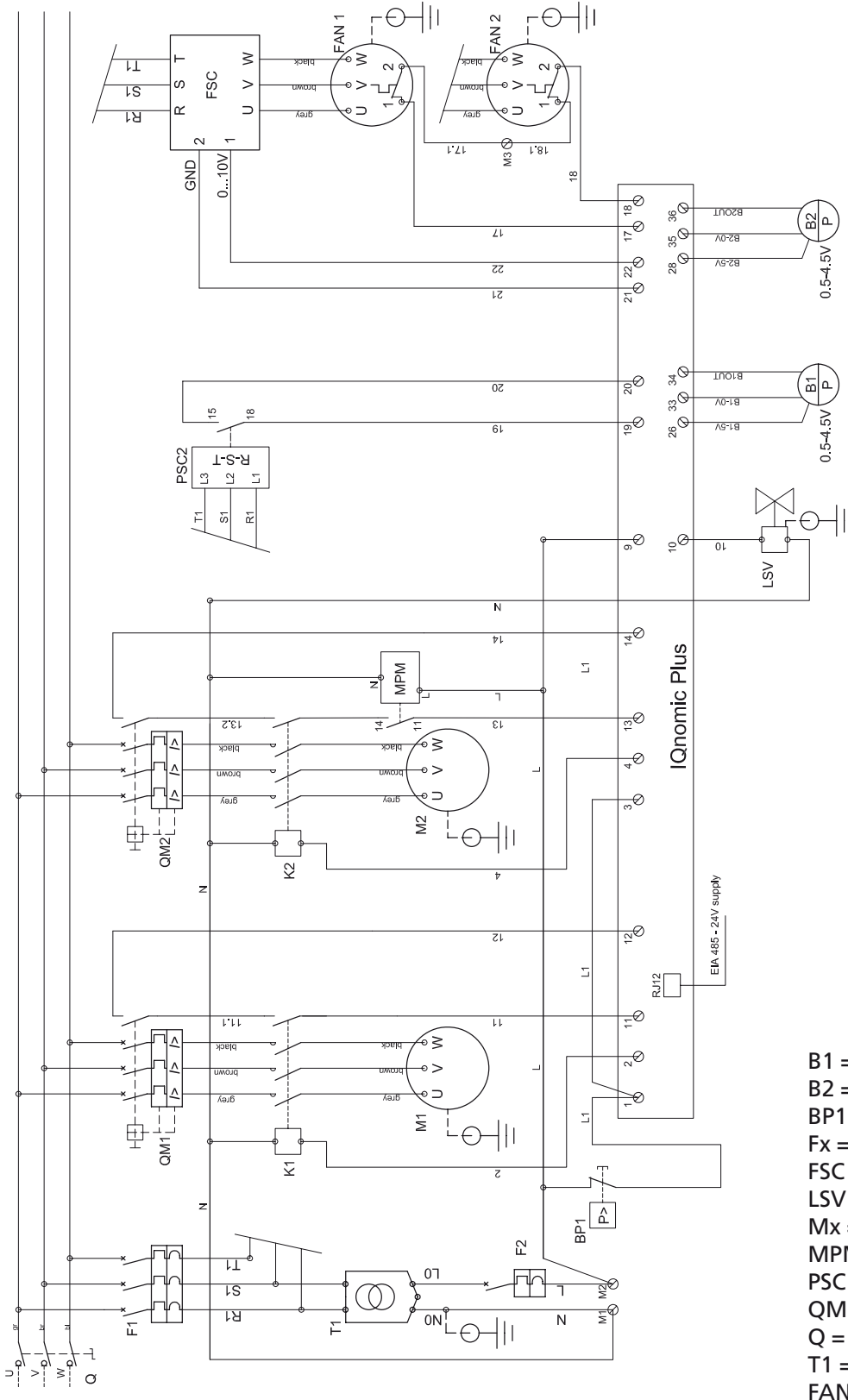

- B1 = High pressure sensor
- B2 = Low pressure sensor
- BP1 = High pressure switch
- Fx = Fuse
- FSC = Control, fan speed
- LSV = Solenoid valve.
- Mx = Cooling compressor
- MPM = Module, motor protection
- PSC = Control, phase sequence
- QM = Motor protection
- Q = Load separator
- T1 = Transformer
- FAN = Fan

12.4 COOL DXS size 60, capacity variant 2 and size 80, capacity variant 1

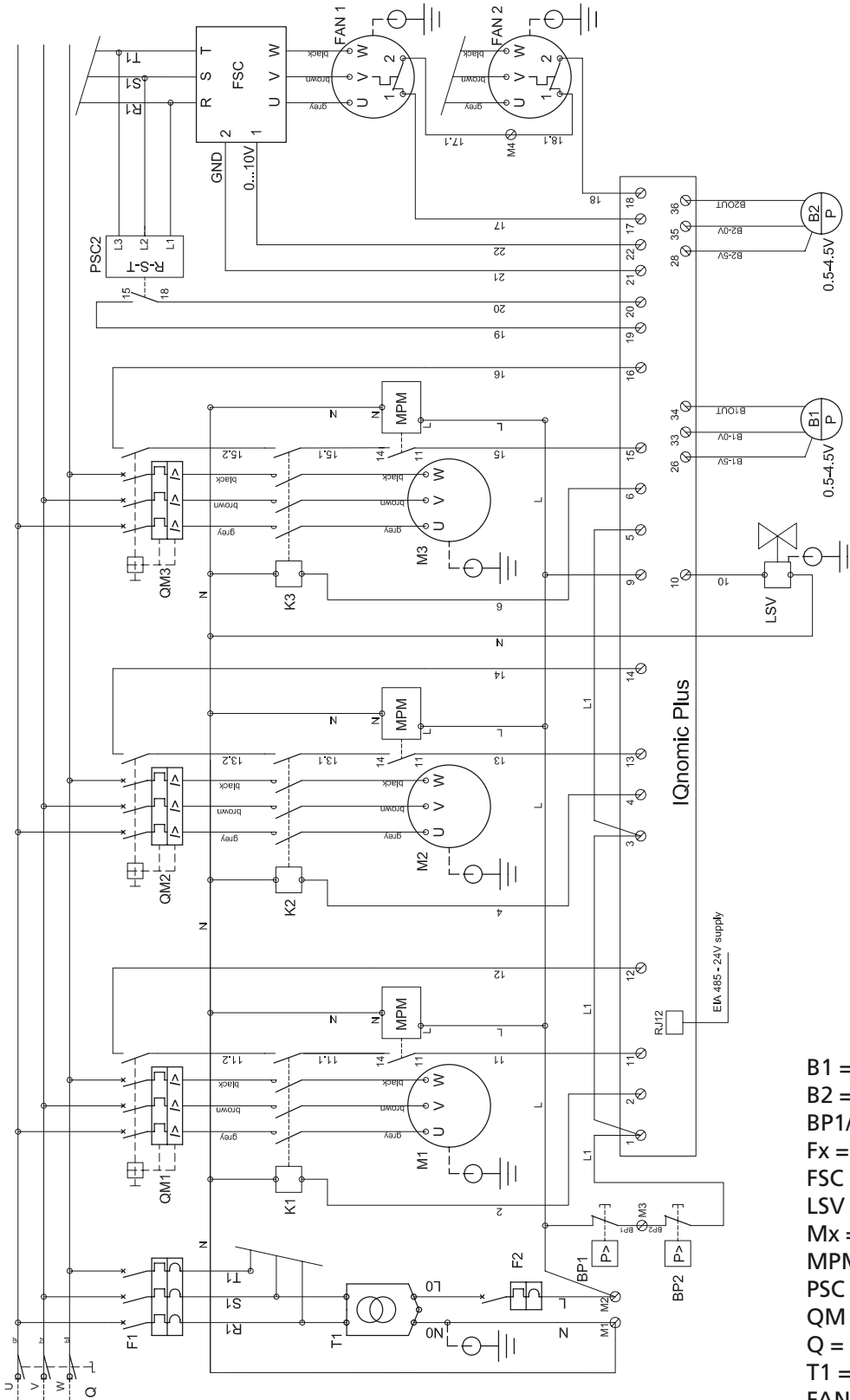

- B1 = High pressure sensor
- B2 = Low pressure sensor
- BP1/BP2 = High pressure switch
- Fx = Fuse
- FSC = Control, fan speed
- LSV = Solenoid valve.
- Mx = Cooling compressor
- MPM = Module, motor protection
- PSC = Control, phase sequence
- QM = Motor protection
- Q = Load separator
- T1 = Transformer
- FAN = Fan

12.5 COOL DXS size 80, capacity variant 2

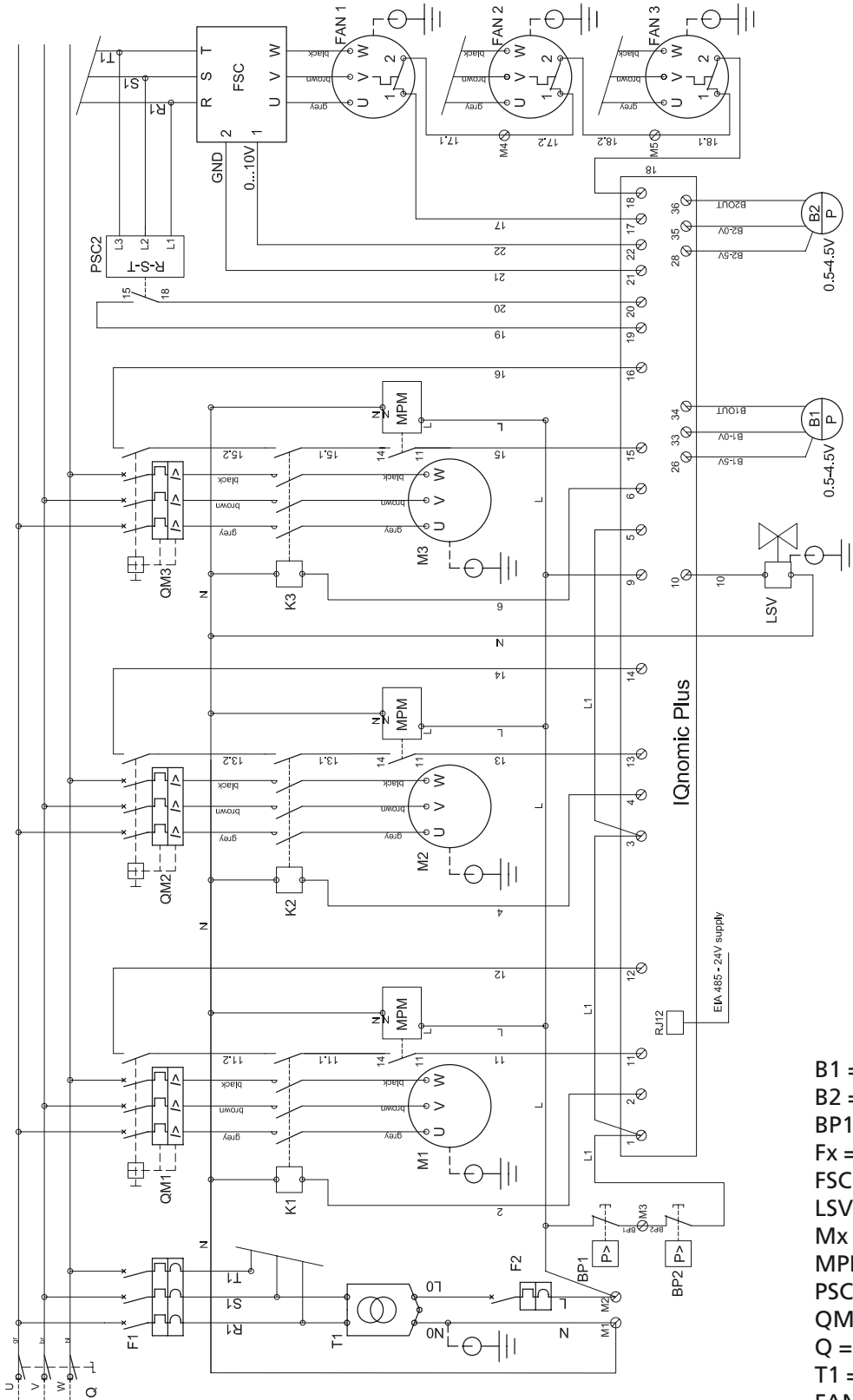

- B1 = High pressure sensor
- B2 = Low pressure sensor
- BP1/BP2 = High pressure switch
- Fx = Fuse
- FSC = Control, fan speed
- LSV = Solenoid valve.
- Mx = Cooling compressor
- MPM = Module, motor protection
- PSC = Control, phase sequence
- QM = Motor protection
- Q = Load separator
- T1 = Transformer
- FAN = Fan

13 Commissioning Record

Company

Our reference

Client	Date	SO No.
Plant	Project/Air handling unit	Subject No:
Plant address	Type/size	

Installation/connections

Inspection measure	Approved/ Done	Remarks
Installation according to instructions	<input type="checkbox"/>	
Condensate drainage correctly connected (if necessary)	<input type="checkbox"/>	
Electrical connections installed according to instructions	<input type="checkbox"/>	
Control cable from COOL DXS to GOLD connected according to instructions	<input type="checkbox"/>	
Rotation direction, cooling compressor checked	<input type="checkbox"/>	
Rotation direction condenser, fan checked	<input type="checkbox"/>	

Item inspected	COOL DXS, size	Factory-preset value	Checked value
Prot. motor switch, Compressor 1 Prot. motor switch, Compressor 2	<input type="checkbox"/> 12-1	13.0 A	_____
		13.0 A	_____
	<input type="checkbox"/> 12-2	15.0 A	_____
		15.0 A	_____
	<input type="checkbox"/> 20-1	15.0 A	_____
		15.0 A	_____
	<input type="checkbox"/> 20-2	22.0 A	_____
		22.0 A	_____
	<input type="checkbox"/> 30-1	22.0 A	_____
22.0 A		_____	
<input type="checkbox"/> 30-2	22.0 A	_____	
	35.0 A	_____	
<input type="checkbox"/> 40-1	22.0 A	_____	
	35.0 A	_____	
<input type="checkbox"/> 40-2	29.0 A	_____	
	51.0 A	_____	
<input type="checkbox"/> 60-1	29.0 A	_____	
	51.0 A	_____	
Prot. motor switch, Compressor 1 Prot. motor switch, Compressor 2 Prot. motor switch, Compressor 3	<input type="checkbox"/> 60-2	36.0 A	_____
		36.0 A	_____
		36.0 A	_____
	<input type="checkbox"/> 80-1	36.0 A	_____
		36.0 A	_____
		36.0 A	_____
	<input type="checkbox"/> 80-2	51.0 A	_____
		51.0 A	_____
		51.0 A	_____

Item inspected	COOL DXS, size	Factory-preset value	Checked value
IQnomic+, function switch 1 IQnomic+, function switch 2	<input type="checkbox"/> 12-1	1 <hr/> 0 <hr/>	<hr/> <hr/>
	<input type="checkbox"/> 12-2	1 <hr/> 1 <hr/>	<hr/> <hr/>
	<input type="checkbox"/> 20-1	1 <hr/> 3 <hr/>	<hr/> <hr/>
	<input type="checkbox"/> 20-2	1 <hr/> 4 <hr/>	<hr/> <hr/>
	<input type="checkbox"/> 30-1	1 <hr/> 6 <hr/>	<hr/> <hr/>
	<input type="checkbox"/> 30-2	1 <hr/> 7 <hr/>	<hr/> <hr/>
	<input type="checkbox"/> 40-1	1 <hr/> 9 <hr/>	<hr/> <hr/>
	<input type="checkbox"/> 40-2	1 <hr/> A <hr/>	<hr/> <hr/>
	<input type="checkbox"/> 60-1	1 <hr/> C <hr/>	<hr/> <hr/>
	<input type="checkbox"/> 60-2	1 <hr/> D <hr/>	<hr/> <hr/>
	<input type="checkbox"/> 80-1	1 <hr/> E <hr/>	<hr/> <hr/>
	<input type="checkbox"/> 80-2	1 <hr/> F <hr/>	<hr/> <hr/>