

GLOBAL PX/RX/LP

Operation and maintenance instructions

Applicable to program versions TAC5 – Version DT 2.8.12 & DG 2.7.3

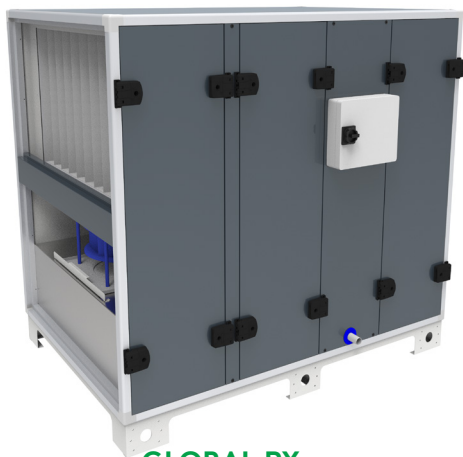

GLOBAL PX

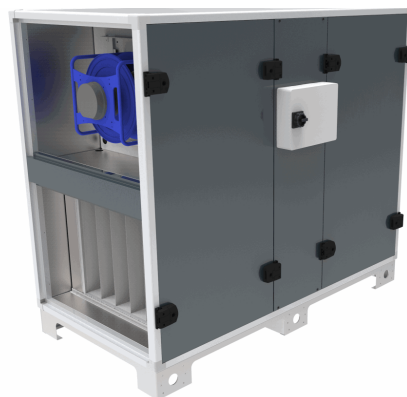

GLOBAL RX

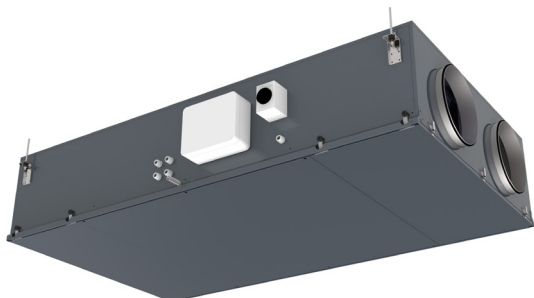

GLOBAL LP



GLOBAL PX ^{FW}



GLOBAL PX TOP^{FW}



GLOBAL RX TOP

GLOBAL PX/RX/LP

Table of content

- 1.0 Safety precautions
- 2.0 Symbols and abbreviations
- 3.0 Product Overview
- 4.0 Wiring Overview
- 5.0 Functions
- 6.0 Commissioning
 - 6.1 Commissioning with Touchscreen interface
- 7.0 Preventive maintenance
- 8.0 Troubleshooting
- 9.0 Parameters/Commissioning Sheet
- 10.0 CE Declaration

1.0 Installation manual

Applicable for the following units

EXCHANGER	SIZES	INTEGRATED PRE-HEATING	INTEGRATED POST-HEATING	HANDING	FAN
GLOBAL PX^{FW} Counterflow	800/1200/2000/ 3000/4000/6000	Yes, electrical	Yes, electrical or water	Left/Right	Forward (FW)
GLOBAL PX Counterflow	800/1200/2000/ 3000/4000/6000	Yes, electrical	Yes, electrical or water	Left/Right	Backward
GLOBAL PX Counterflow	04/05/08/10/12/13/ 14/16/20/24/26	Yes, electrical	Yes, electrical or water	Left/Right	Backward Composite or Aluminum
GLOBAL PX TOP^{FW} Counterflow	800/1200/2000	Yes, electrical	Yes, electrical or water	Right	Forward (FW)
GLOBAL PX TOP Counterflow	05/08/10/12/14/18	Yes, electrical	Yes, electrical or water	Left/Right	Backward
GLOBAL RX Rotary	05/08/10/12/13/ 14/16/18/20/24/26	No	Yes, electrical or water	Left/Right	Backward
GLOBAL RX TOP Rotary	05/08/10/12/ 13/14/16	No	Yes, electrical or water	Left/Right	Backward
GLOBAL LP^{FW} Counterflow	450/600/1000/ 1300/1600/2000	Yes, electrical	No	Left/Right	Forward (FW)
GLOBAL LP Counterflow	02/04/06/08 10/12/13/14/16/18	Yes, electrical	Yes, electrical or water	Left/Right	Backward

Disclaimer

Danger/Warning/Caution

- All staff concerned shall acquaint themselves with these instructions before beginning any work on the unit. Any damages to the unit or its components caused by improper handling or misuse by the purchaser or the installer cannot be considered subject to guarantee if these instructions have not been followed correctly.
- Make sure that the power supply to the unit is disconnected before performing any maintenance or electrical work!
- All electrical connections must be carried out by an authorized installer and in accordance with local rules and controls.
- Although the mains supply to the unit has been disconnected there is still risk for injury due to rotating parts that have not come to a complete standstill.
- Beware of sharp edges during mounting and maintenance. Make sure that a proper lifting device is used. Use protective clothing.
- Unit should always be operated with closed doors and panels.
- If the unit is installed in a cold place make sure that all joints are covered with insulation and are well taped.
- Duct connections/duct ends should be covered during storage and installation, in order to avoid condensation inside of the unit.
- Check that there are no foreign objects in unit, ducting system or functional sections.
- The unit is packed to prevent damage of the external and internal parts of the unit, dust and moisture penetration. If the unit is not to be installed immediately, it should be stored in a clean, dry area. If stored externally, it should be adequately protected from the weather influence.

RANGE OF APPLICATION

The GLOBAL units are designed for use in comfort ventilation applications.

Depending on the variant selected, GLOBAL units can be utilised in buildings such as office buildings, schools, day nurseries, public buildings, shops, residential buildings, etc.

GLOBAL units equipped with plate heat exchangers can also be used for the ventilation of moderately humid buildings; however not where the humidity is continuously high, such as in indoor swimming baths, saunas, spas or wellness centres.

Please do contact us if you have a need for a unit that is suited for such an application.













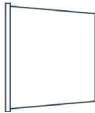





HOW TO READ THIS DOCUMENT

Please make sure that you have read and understood the safety precautions below.

Please read chapter 2 where the Symbols and Abbreviations used for GLOBAL are listed and Chapter 5 where the operating principles of a GLOBAL air handling unit are described. The commissioning of the unit is described in chapter 6.

The commissioning chapter is divided based on what device (Remote Control, Graphical Remote Control or App) is used to control the unit. Simply go to the sub chapter, relevant for your device and the base setup for the operating mode which will be used to control the unit.

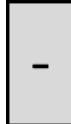
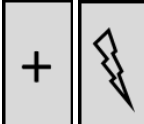
2.0 Symbols and abbreviations

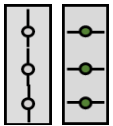
	BW	BACKWARD CURVED FAN		FW	FORWARD CURVED FAN
	BF	BAG FILTER		PF	PLEATED FILTER
	RX	ROTARY HEAT EXCHANGER		PX	PLATE HEAT EXCHANGER
	WARNING				
	Must be connected by a qualified Electrician. Warning! Hazardous voltage.				
	OUTDOOR AIR		Air from outdoor to the AHU		
	SUPPLY AIR		Air from the AHU to the building		
	EXTRACT AIR		Air from the building to the AHU		
	EXHAUST AIR		Air from the AHU to outdoor		
	COOLING COIL	BA-		IBA/KW	HEATING COIL (WATER / ELECTRICAL)
	SILENCER	GD		CTm	MOTORIZED DAMPER
	PRESSURE SENSOR	P		Tx	TEMPERATURE SENSOR Nr = x (1,2,3...)
	SLIP CLAMP	SC		MS	FLEXIBLE CONNECTION
CIRCULAR DUCT CONNECTION		ER	For inlet	SR	For outlet

3.0 Product Overview

GENERAL OVERVIEW

RIGHT HAND UNIT (SUPPLY AIR TO THE RIGHT)

LEFT HAND UNIT (SUPPLY AIR TO THE LEFT)

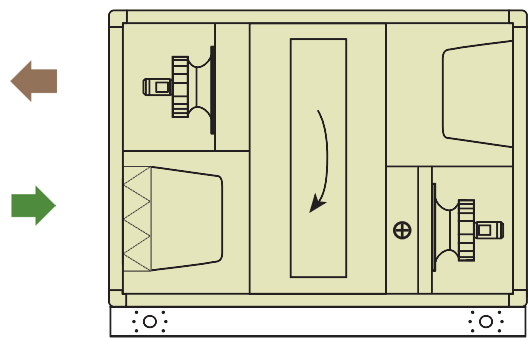

GLOBAL RX

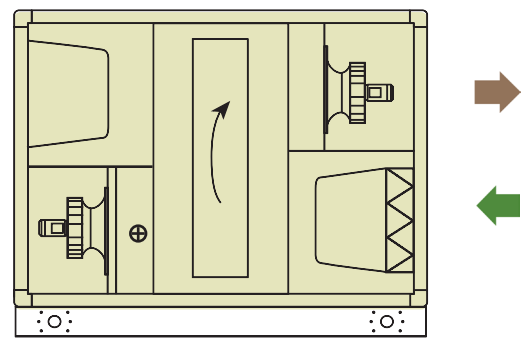

GLOBAL RX

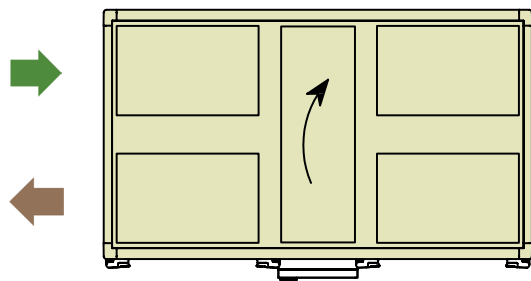

GLOBAL RX TOP

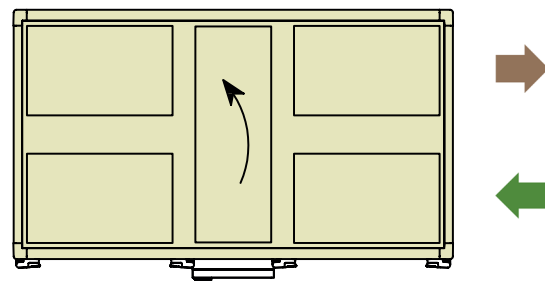

GLOBAL RX TOP

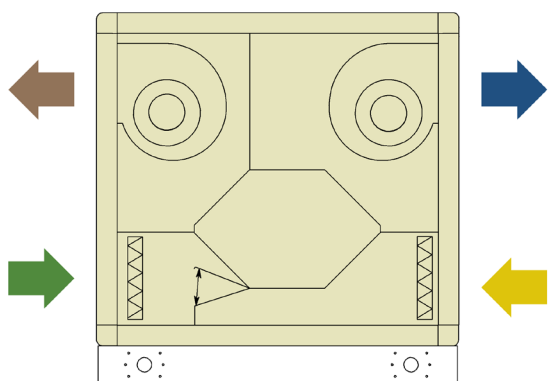

GLOBAL PX^(FW)

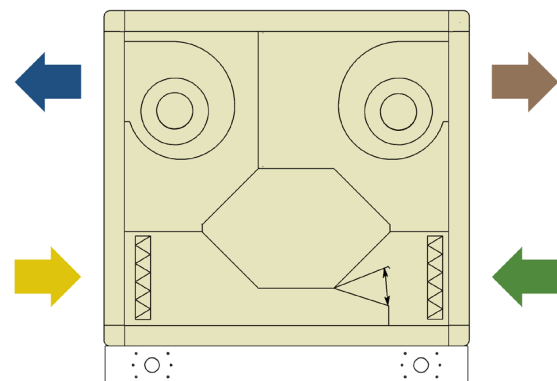

GLOBAL PX^(FW)

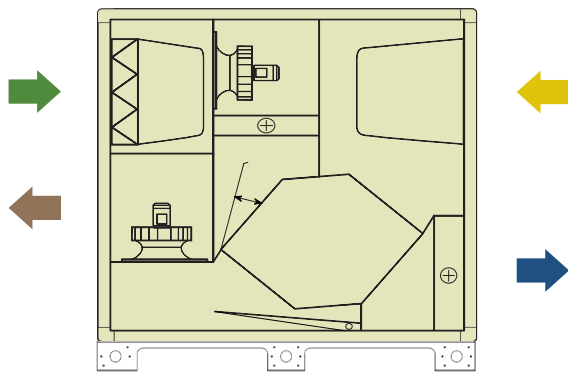

GLOBAL PX

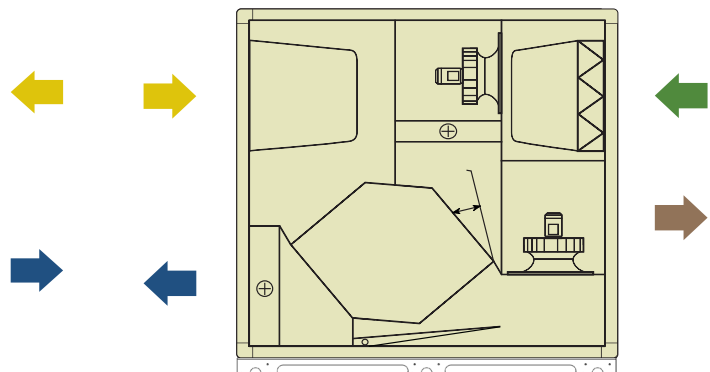

GLOBAL PX

RIGHT HAND UNIT (SUPPLY AIR TO THE RIGHT)

LEFT HAND UNIT (SUPPLY AIR TO THE LEFT)

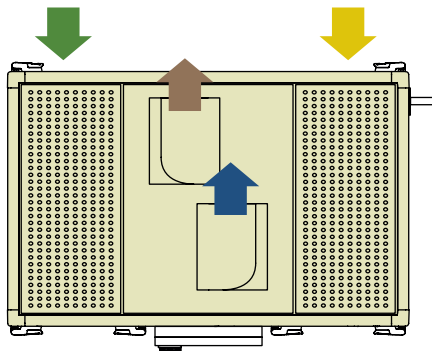

GLOBAL PX TOP^{FW}

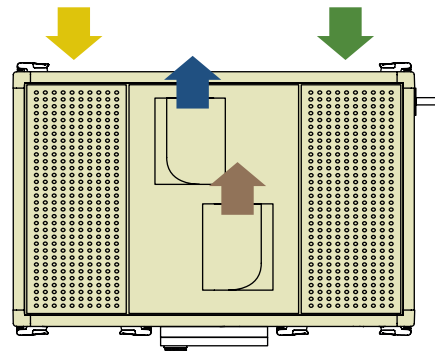

GLOBAL PX TOP^{FW}

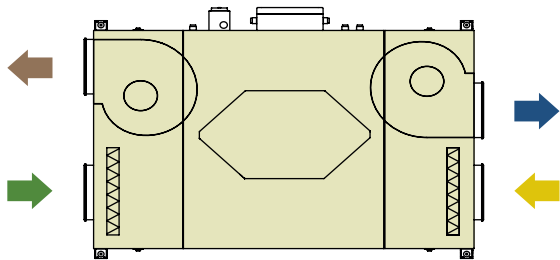

GLOBAL LP 450^{FW} (BOTTOM view)

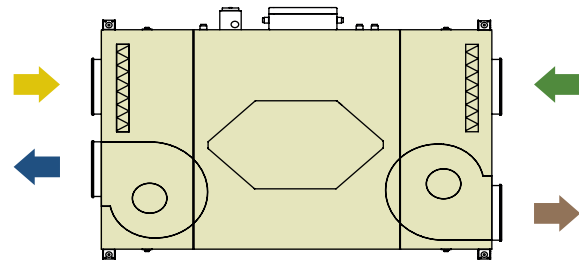

GLOBAL LP 450^{FW} (BOTTOM view)

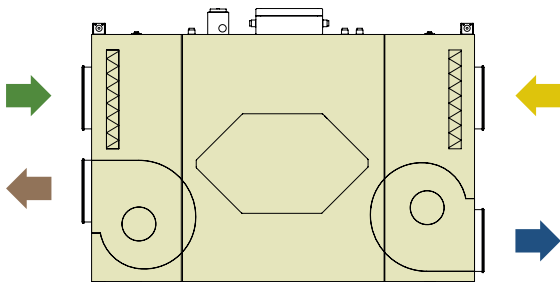

GLOBAL LP 600 - 2000^{FW} (BOTTOM view)

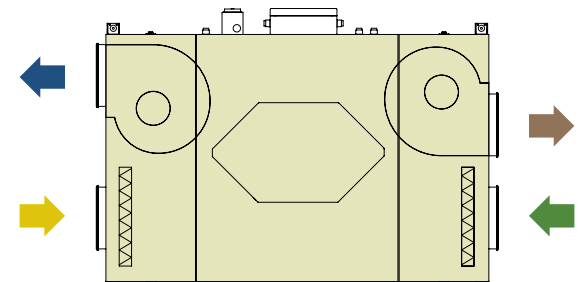

GLOBAL LP 600 - 2000^{FW} (BOTTOM view)

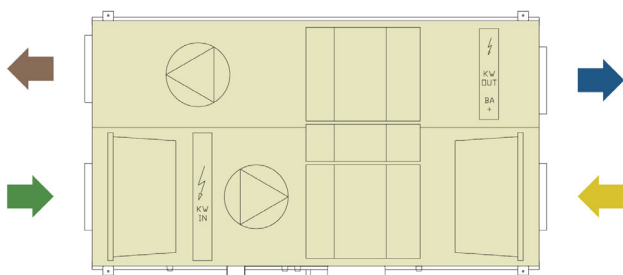

GLOBAL LP (TOP view)

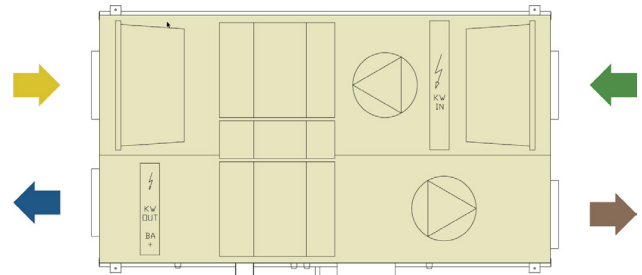

GLOBAL LP (TOP view)

ATTENTION



Right and left hand units have different article numbers and should be ordered accordingly. Main version described in the manuals is always the hand right version.

The difference between left and right LP units is the factory placement of the controls box on opposite sides.

RIGHT HAND UNIT (SUPPLY AIR TO THE RIGHT)

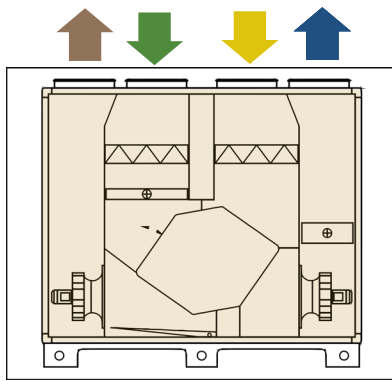

PX TOP 05 - 10

LEFT HAND UNIT (SUPPLY AIR TO THE LEFT)

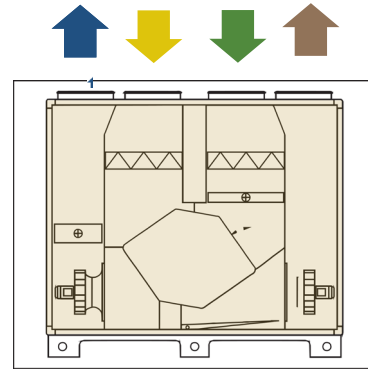

PX TOP 05 - 10

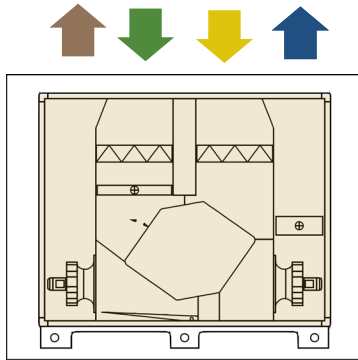

PX TOP 12 - 18

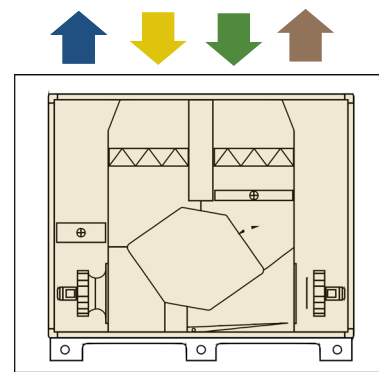

PX TOP 12 - 18

COMPONENTS GLOBAL PX

GLOBAL PX

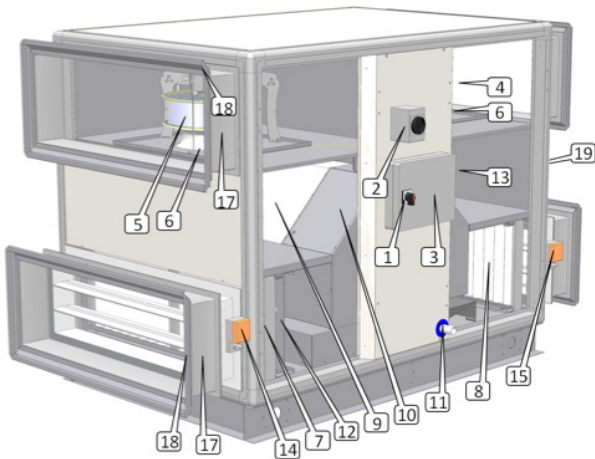

GLOBAL PX TOP^{FW}

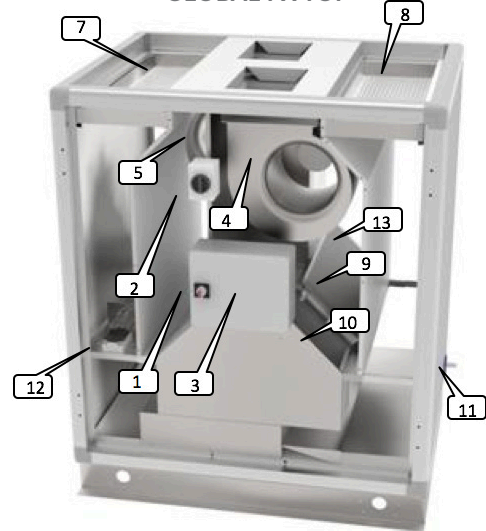

GLOBAL PX

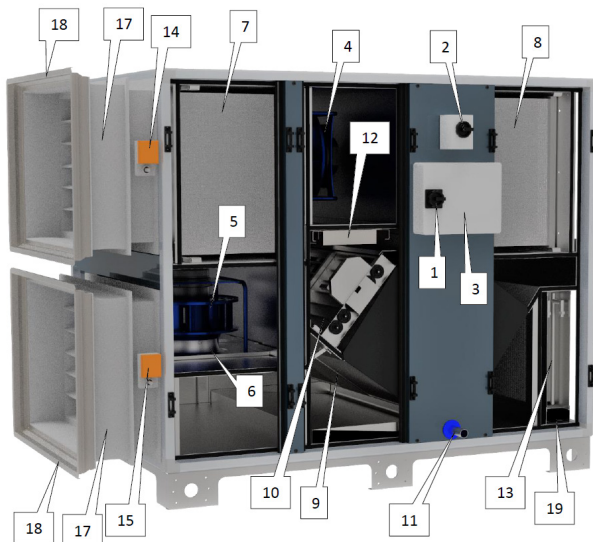

- | | |
|--|---|
| <ol style="list-style-type: none"> 1. Main power switch 2. Main power switch for electrical coils (both internal pre-heating and post-heating) 3. Wiring box TAC5 controller 4. Supply fan 5. Extract fan 6. Kit CA -airflow measurement (option) 7. Outdoor air filter (bag or pleated) 8. Extract air filter (bag or pleated) 9. Heat exchanger (Plate) | <ol style="list-style-type: none"> 10. Modulating 100% by-pass 11. Drain pan and drain pipe 12. Pre-heating electrical antifrost coil 13. Internal post-heating water or electrical coil (accessory) 14. Motorized damper (at outdoor air side - accessory) 15. Motorized damper (at exhaust air side - accessory) 17. Flexible connection(accessory) 18. Slip Clamps (accessory) 19. Water connection for postheating (accessory) |
|--|---|



1, 2 and 3 must be installed by an accredited electrician

Note: internal electrical coils, motorized dampers, internal fan-pressure sensors, flexible connections and slip-clamps have to be ordered initially and are all pre-mounted and factory wired. Internal heating water-coil accessory is pre-mounted but has to be hydraulically and electrically connected by the installer.

AIR VOLUMES AND DIMENSIONS - GLOBAL PX

GLOBAL PX^(FW)

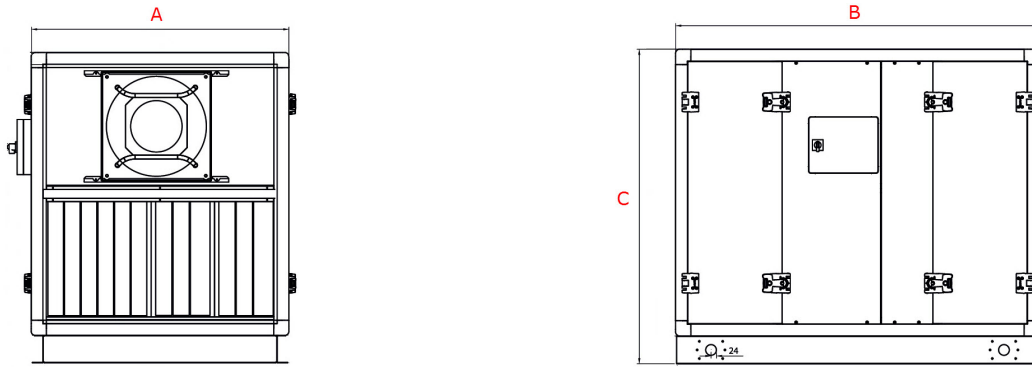

EXCHANGER	SIZE	AIR VOLUME		A [mm]	B [mm]	C [mm]	Weight [kg]	
GLOBAL PX Counterflow	800 ^(FW)	840m ³ /h	230 l/s	575	1210	1235	185	
	1200 ^(FW)	1260 m ³ /h	350 l/s	940	1210	1235	245	
	2000 ^{FW}	2100 m ³ /h	580 l/s	1105	1635	1230	320	
	2000					1360	375	
	3000 ^{FW}	3150 m ³ /h	875 l/s	1475	1635	1230	370	
	3000					1360	415	
	4000 ^{FW}	4200 m ³ /h	1165 l/s	1845	1635	1230	505	
	4000					1360	545	
	5000 ^{FW}	5250 m ³ /h	1455 l/s	2135	1635	1600	655	
	5000					1760	685	
	6000 ^{FW}	6300 m ³ /h	1750 l/s	2135	1635	1600	685	
	6000					1760	710	
GLOBAL PX Counterflow	04							
	05	1060 m ³ /h	295 l/s	610	1680	1465	330	
	08	1680 m ³ /h	465 l/s	815	1680	1465	370	
	10	1860 m ³ /h	515 l/s	995	1680	1465	410	
	12	2300 m ³ /h	640 l/s	1182	1680	1465	420	
	13	2530 m ³ /h	700 l/s	1182	1680	1465	420	
	14	3000 m ³ /h	830 l/s	1382	1680	1465	480	
	16	3230 m ³ /h	895 l/s	1640	1680	1465	520	
	20	4700 m ³ /h	1300 l/s	1640	2557	1825	930	
	24	6260 m ³ /h	1740 l/s	2015	2557	1825	1120	
	26	7080 m ³ /h	1960 l/s	2396	2557	1825	1260	

COMPONENTS GLOBAL PX TOP

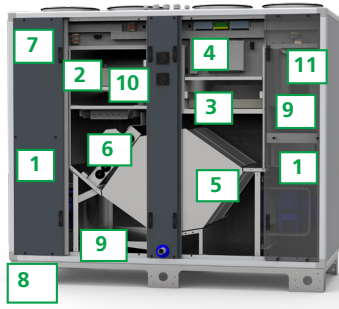

1. EC Plug fan w/ composite fan blades (aluminium blades optional)
2. Fresh air filter ePM1 \geq 60% filter class
3. Extract air filter ePM1 \geq 50% filter class
4. Integrated TAC5 controller
5. High efficiency counterflow plate heat exchanger
6. Modulating 100% BYPASS
7. Stainless steel drain pan
8. Base frame for easy on site transport
9. Integrated post-heating (water/electrical)
10. Integrated pre-heating (electrical)
11. Silencer

AIR VOLUMES AND DIMENSIONS GLOBAL PX TOP

EXCHANGER	SIZE	AIR VOLUME		A [mm]	B [mm]	C [mm]	Weight [kg]
		m ² /h	l/s				
GLOBAL PX TOP Counterflow	05	200-940	60-260	610	1680	1465	330
	08	200-1500	60-410	815	1680	1465	380
	10	300-1900	80-520	815	1960	1725	470
	12	300-2550	80-700	995	1960	1725	530
	14	300-2850	80-790	1182	1960	1725	590
	18	400-3700	110-1020	1382	1960	1725	670

GLOBAL LP^{FW}

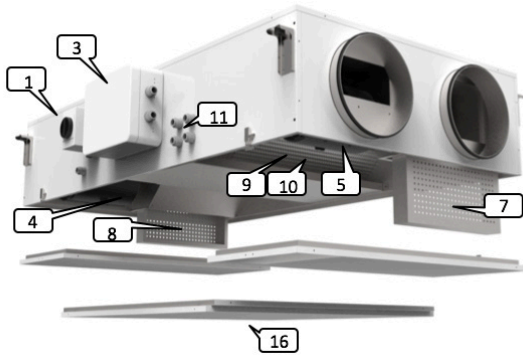

GLOBAL LP

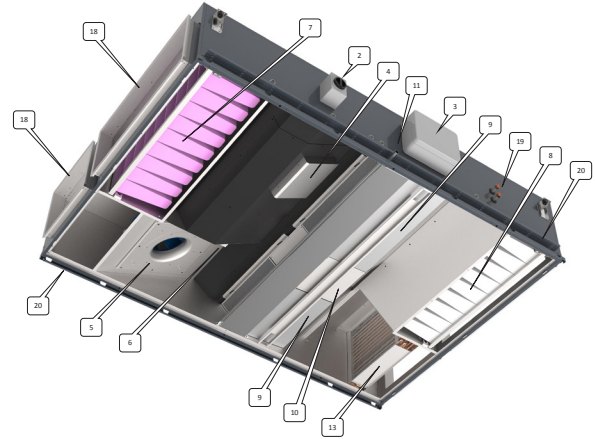

1. Main power switch
2. Main power switch for electrical coils (both internal pre-heating and post-heating)
3. Wiring box TAC5 controller
4. Supply fan
5. Extract fan
6. Kit CA -airflow measurement (option)
7. Outdoor air filter (bag or pleated)
8. Extract air filter (bag or pleated)
9. Heat exchanger (Plate)

10. Modulating 100% by-pass
11. Drain pan and drain pipe
12. Pre-heating electrical antifrost coil
13. Internal post-heating water or electrical coil (accessory)
14. Motorized damper (at outdoor air side - accessory)
15. Motorized damper (at exhaust air side - accessory)
16. Access panel
17. Flexible connection (accessory)
18. Slip Clamps (accessory)
19. Water connection for postheating (accessory)



1, 2 and 3 must be installed by an accredited electrician

Note: internal electrical coils, motorized dampers, internal fan-pressure sensors, flexible connections and slip-clamps have to be ordered initially and are all pre-mounted and factory wired. Internal heating water-coil accessory is pre-mounted but has to be hydraulically and electrically connected by the installer.

AIR VOLUMES AND DIMENSIONS - GLOBALP

GLOBAL LP^(FW)

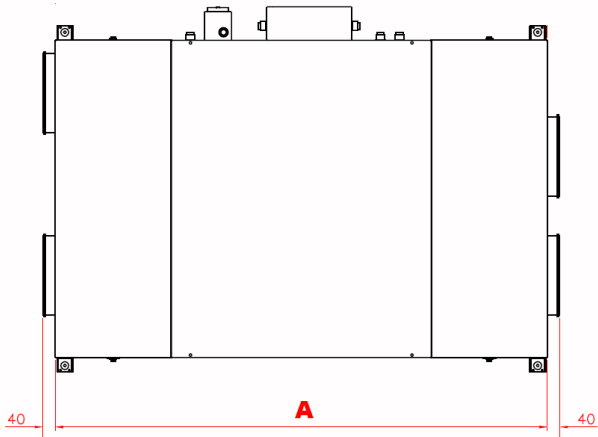

GLOBAL LP^(FW)

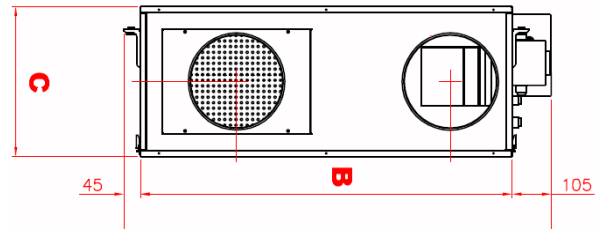

EXCHANGER	SIZE	AIR VOLUME		A [mm]	B [mm]	C [mm]	Weight [kg]
GLOBAL LP Counterflow	450 ^{FW}	475 m ³ /h	130 l/s	1100	560	360	75
	600 ^{FW}	630 m ³ /h	175 l/s	1490	850	320	110
	1000 ^{FW}	1050 m ³ /h	290 l/s	1550	1000	400	160
	1300 ^{FW}	1350 m ³ /h	375 l/s	1550	1640	400	225
	1600 ^{FW}	1680 m ³ /h	465 l/s	1550	1640	400	225
	2000 ^{FW}	2100 m ³ /h	583 l/s	1700	1940	400	275
	02	580 m ³ /h	160 l/s	1300	890	350	105
	04	650 m ³ /h	180 l/s	1300	1100	350	125
	06	1000 m ³ /h	280 l/s	2100	1050	435	195
	08	1420 m ³ /h	395 l/s	2100	1300	435	230
	10	1800 m ³ /h	500 l/s	2180	1600	435	285
	12	2200 m ³ /h	610 l/s	2350	1700	510	335
	13	2550 m ³ /h	705 l/s	2350	1700	510	335
	14	2870 m ³ /h	795 l/s	2350	1940	510	370
	16	3300 m ³ /h	915 l/s	2900	1935	660	610
18	3720 m ³ /h	1030 l/s	2900	1935	660	610	

COMPONENTS GLOBAL RX

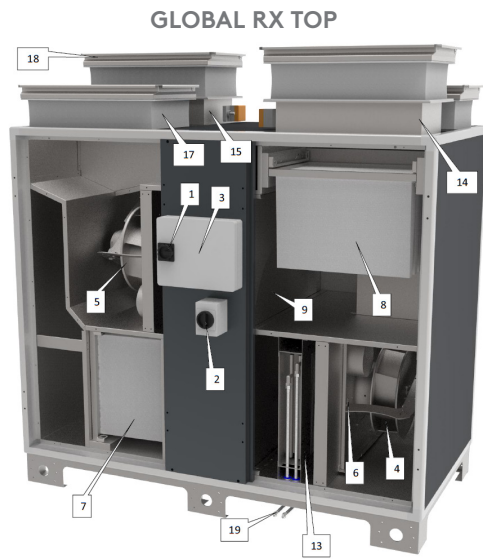

1. Main power switch
2. Main power switch for electrical coils (both internal pre-heating and post-heating)
3. Wiring box TAC5 controller
4. Supply fan
5. Extract fan
6. Kit CA -airflow measurement (option)
7. Outdoor air filter (bag)
8. Extract air filter (bag)
9. Heat exchanger (Rotary)
13. Internal post-heating water or electrical coil (accessory)
14. Motorized damper (at outdoor air side - accessory)
15. Motorized damper (at exhaust air side - accessory)
17. Flexible connection (accessory)
18. Slip Clamps (accessory)
19. Water connection for postheating (accessory)



1, 2 and 3 must be installed by an accredited electrician

Note: internal electrical coils, motorized dampers, internal fan-pressure sensors, flexible connections and slip-clamps have to be ordered initially and are all pre-mounted and factory wired. Internal heating water-coil accessory is pre-mounted but has to be hydraulically and electrically connected by the installer.

AIR VOLUMES AND DIMENSIONS - GLOBAL RX

GLOBAL RX (TOP)

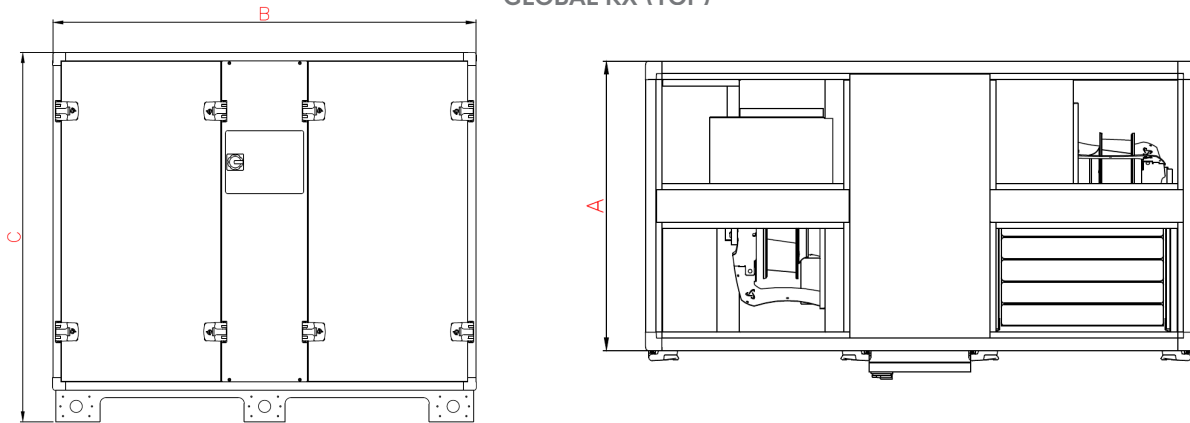

EXCHANGER	SIZE	AIR VOLUME		A [mm]	B [mm]	C [mm]	Weight [kg]
GLOBAL RX TOP Rotary	05	1050 m ³ /h	290 l/s	815	1530	1315	310
	08	1400 m ³ /h	390 l/s	815	1530	1315	315
	10	1690 m ³ /h	470 l/s	885	1680	1465	370
	12	2140 m ³ /h	590 l/s	885	1680	1465	365
	13	2430 m ³ /h	680 l/s	995	1680	1465	390
	14	3050 m ³ /h	850 l/s	1182	1680	1465	425
	16	3140 m ³ /h	870 l/s	1182	1680	1465	430
GLOBAL RX Rotary	05	1160 m ³ /h	320 l/s	815	1530	1315	305
	08	1680 m ³ /h	465 l/s	815	1530	1315	310
	10	1750 m ³ /h	485 l/s	885	1680	1465	360
	12	2350 m ³ /h	650 l/s	885	1680	1465	340
	13	2900 m ³ /h	800 l/s	995	1680	1465	365
	14	3150 m ³ /h	875 l/s	1182	1680	1465	385
	16	4500 m ³ /h	1250 l/s	1382	1880	1725	535
	18	5500 m ³ /h	1525 l/s	1382	1880	1725	535
	20	5500 m ³ /h	1525 l/s	1382	1880	1725	535
	24	6640 m ³ /h	1840 l/s	1640	1880	1725	575
	26	7100 m ³ /h	1970 l/s	1640	1880	1725	590

Duct connections: see drawings downloadable on our website.

4.0 Wiring Overview

MAIN CONTROL BOARD TAC5 DG - CID025000

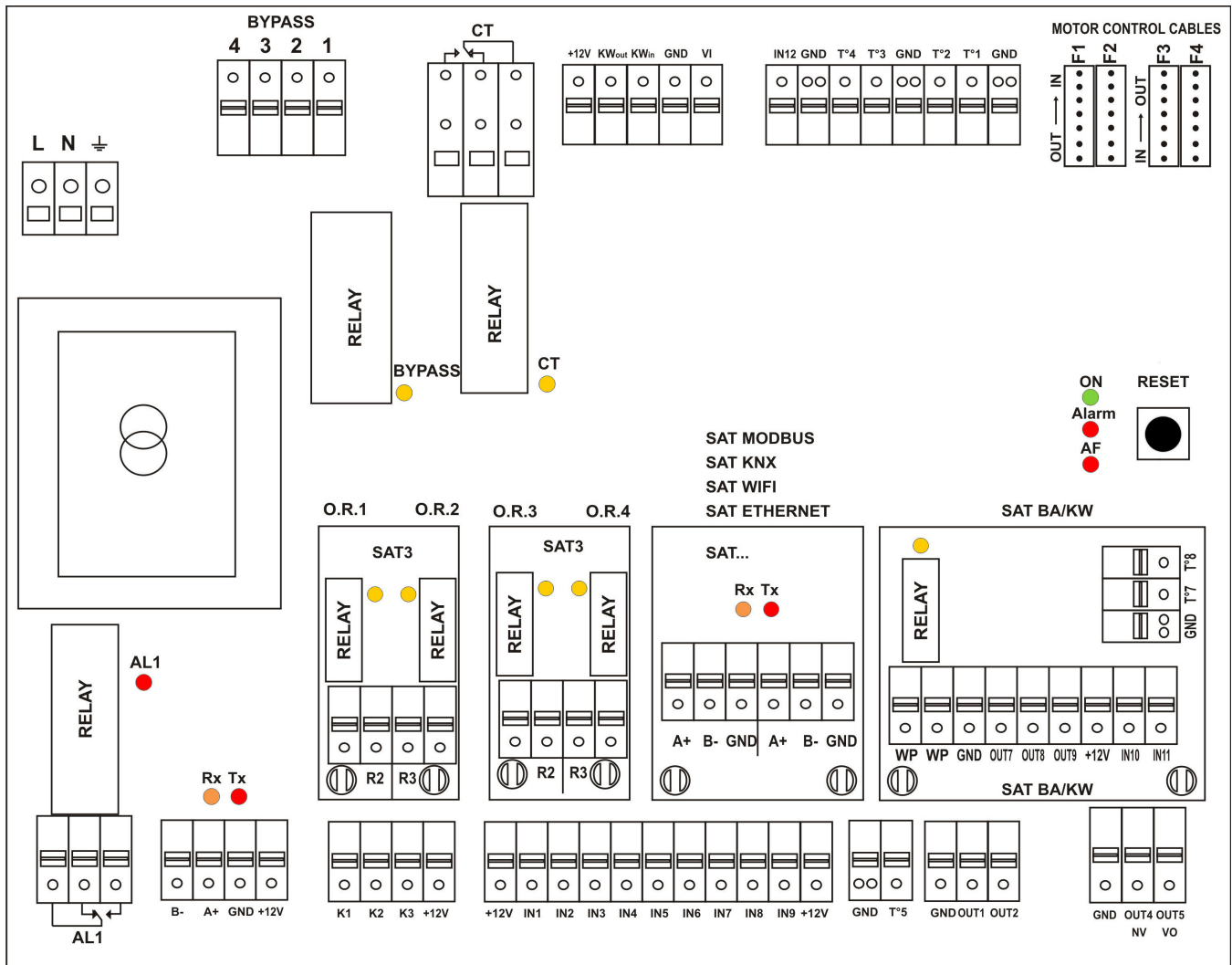

CT = output to CT actuator(s) (option - prewired)	IN1 = Master selection
BYPASS = output to bypass actuator (prewired)	IN2 = dPa (pressostat digital input)
AL1 = ALARM OUTPUT (230V/5A)	IN3 = Fire alarm input
B- /A+ /GND/ +12V = connection to HMI TACTouch	IN4 = Bypass open /Stop heat recovery
K1 : Airflow MODE = m ³ /h K1 Demand/Pressure control = START/STOP Torque MODE = %torque K1	IN5 = Real time clock auto/manu
K2 : Airflow control = m ³ /h K2 Demand/Pressure control = 0-10V INPUT Torque control = %torque K2	IN6 = ON/OFF post heating (IBA/KWout)
K3 : Airflow control = m ³ /h K3 Demand/Pressure control = % ON K3 or 0-10 V INPUT Torque control = %torque K3	IN7 = ON/OFF SUPPLY if fire alarm
T1 = from outdoors T° sensor (prewired)	IN8 = ON/OFF EXHAUST if fire alarm
T2 = from indoors T° sensor (prewired)	IN9 = BOOST Airflow
T3 = to outdoors T° sensor (prewired)	IN12 = PWM input bypass position
T4 = IBA anti freeze protection T° sensor (option - prewired)	OUT1 = 0-10V OUTPUT (airflow/pressure)
T5 = supply T° sensor for IBA/KWout coil (option - prewired)	OUT2 = 0-10V OUTPUT (airflow/pressure)
PR1 = ΔPa from supply inlet fan (only on PX - option)	OUT4 = 0-10V OUTPUT internal post heating (IBA)
PR3 = ΔPa from exhaust inlet fan (only on PX - option)	OUT5 = 24VDC/1A
	O.R.1 (output relay 1 - SAT3) = PRESSURE ALARM
	O.R.2 (output relay 2 - SAT3) = FAN ON
	O.R.3 (output relay 3 - SAT3) = HEATING DEMAND OUTPUT
	O.R.4 (output relay 4 - SAT3) = BYPASS STATUS
	KWIn = output for KWIn capacity control (option - prewired)
	KWout = output for KWout capacity control (option - prewired)

MAIN CONTROL BOARD TAC5 DT - CID026001

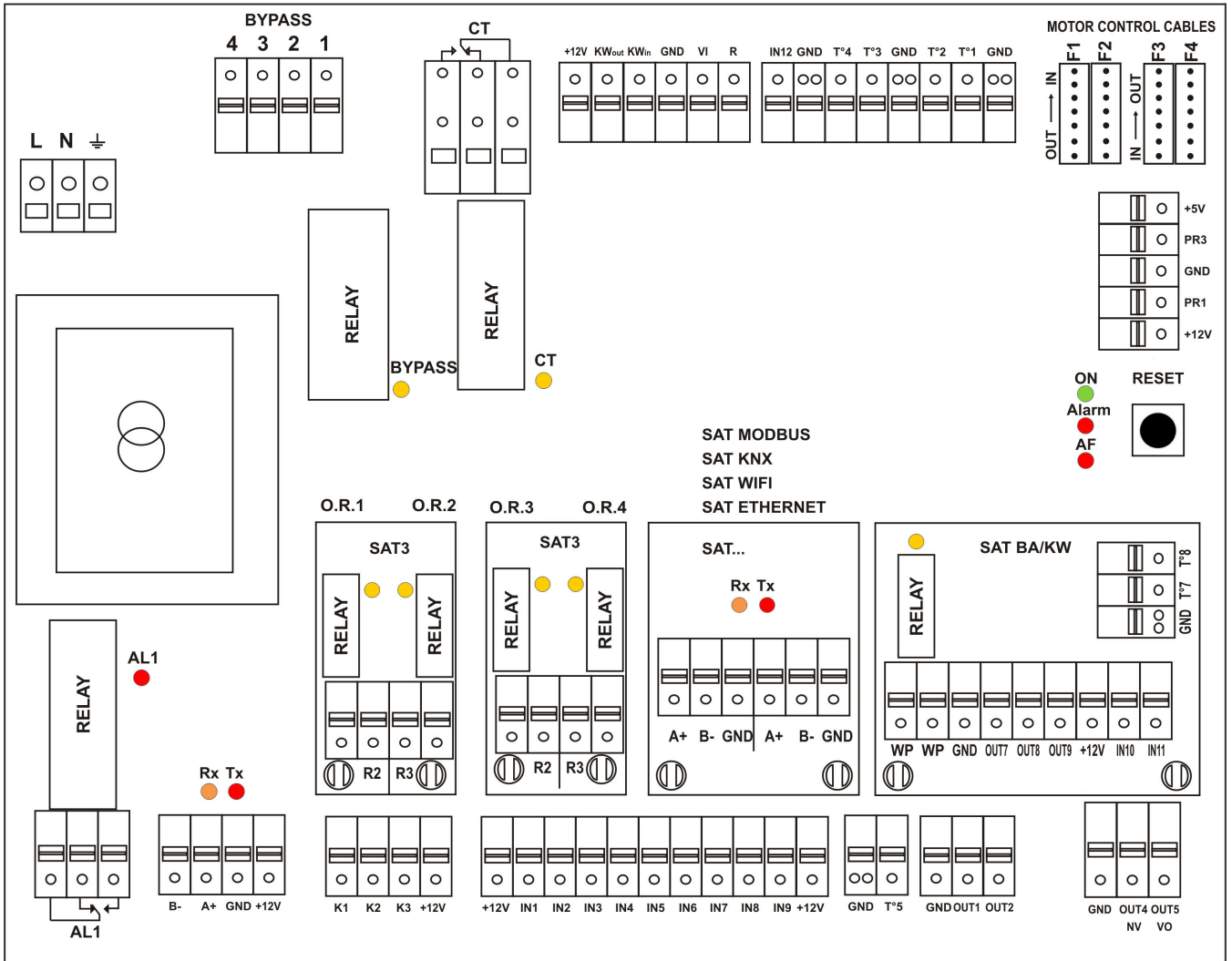

CT : output to CT actuator(s) (option - prewired)	IN1 = Master selection
KWout = output for KWout capacity control (option - prewired)	IN2 = dPa (pressostat digital input)
AL1 = ALARM OUTPUT (230V/5A)	IN3 = Fire alarm input
B- /A+ /GND /+12V = connection to HMI TACtouch	IN4 = Bypass open /Stop heat recovery
K1 : Airflow control = m ³ /h K1 Demand/Pressure control = START/STOP Torque control = %torque K1	IN5 = Real time clock auto/manu
K2 : Airflow control = m ³ /h K2 Demand/Pressure control = 0-10V INPUT Torque control = %torque K2	IN6 = ON/OFF post heating (IBA/KWout)
K3 : Airflow control = m ³ /h K3 Demand/Pressure control = % ON K3 or 0-10 V INPUT Torque control = %torque K3	IN7 = ON/OFF SUPPLY if fire alarm
T1 = from outdoors T° sensor (prewired)	IN8 = ON/OFF EXHAUST if fire alarm
T2 = from indoors T° sensor (prewired)	IN9 = BOOST Airflow
T4 = IBA anti freeze protection T° sensor (option - prewired)	IN12 = input pulse from heat exchanger magnet (prewired)
T5 = supply T° sensor for IBA/KWout coil (option - prewired)	OUT1 = 0-10V OUTPUT (airflow/pressure)
PR1 = ΔPa from supply inlet fan (only on RX - option)	OUT2 = 0-10V OUTPUT (airflow/pressure)
PR3 = ΔPa from exhaust inlet fan (only on RX - option)	OUT4 = 0-10V OUTPUT internal post heating (IBA)
	OUT5 = 24VDC/1A
	O.R.1 (output relay 1 - SAT3) = PRESSURE ALARM
	O.R.2 (output relay 2 - SAT3) = FAN ON
	O.R.3 (output relay 3 - SAT3) = HEATING DEMAND OUTPUT
	O.R.4 (output relay 4 - SAT3) = BYPASS STATUS
	R-GND : output for heat exchanger wheel speed command (prewired)

4.1 CIRCUIT BOARD SAT 3 - CID372005

The SAT3 circuit board is used for extra functions for which inputs and outputs are not included as standard in the control unit of the air handling unit. All outputs are normally open (N.O.). Maximal load: 230VAC-4A. The circuit board SAT3 allows for signalling of the following by means of a potential-free contact:

- Fan status - O.R.1
- Differential pressure alarm - O.R.2
- Heating demand - O.R.3
- Bypass status - O.R.4

Installation

SAT3 must be plugged onto the control board circuit (see fig.1).

Attention: The SAT3 must be plugged in before the circuit is powered. SAT must be plugged in correctly, wrong positioning can damage both circuits permanently.



Fig. 1

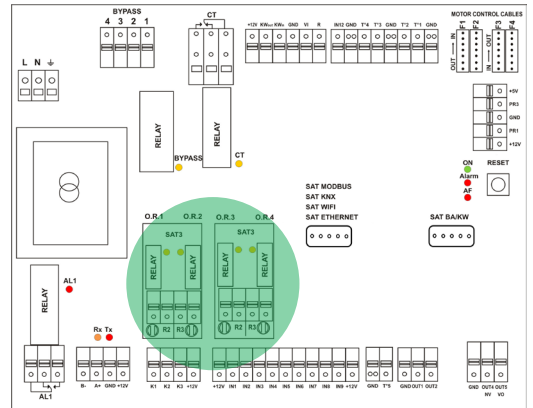

4.2 CIRCUIT BOARD SAT BA/KW - CID372004

SAT TAC5 BA/KW is a satellite circuit designed to be fitted on the main control board. It permits control of external coils.

Installation

The SAT BA/KW must be plugged onto the control board circuit (see Fig.2).

Attention: The SAT TAC5 BA/KW must be plugged in before the circuit is powered. SAT must be plugged in correctly, wrong positioning can damage both circuits permanently.



Fig. 2

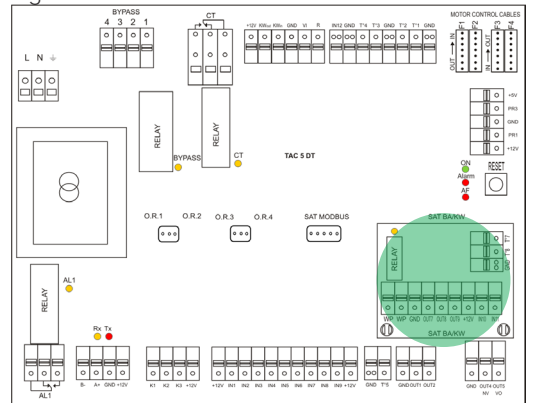

Wiring

The terminals of the SAT BA/KW are displayed in fig.3

- WP WP** = Cooling demand (max. 30 V-2 A)
- OUT7** = 0-10 V output to control heating- or change over capacity.
- OUT8** = 0-10 V output to control cooling capacity
- OUT9** = PWM output to control electrical coil
- T°7** = Heating coil frost protection sensor (T7)
- T°8** = Cooling coil frost protection sensor (T8)
- IN10** = Cooling OFF, (to force heating off use IN6)
- IN11** = Input cooling/heating (open = heating, closed = cooling)

Fig. 3

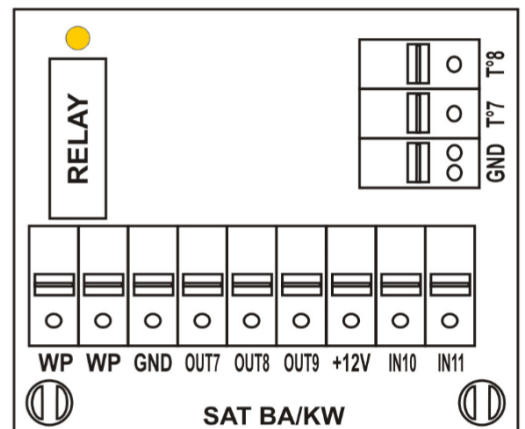

4.3 INTERNAL WIRING DIAGRAM GLOBAL PX

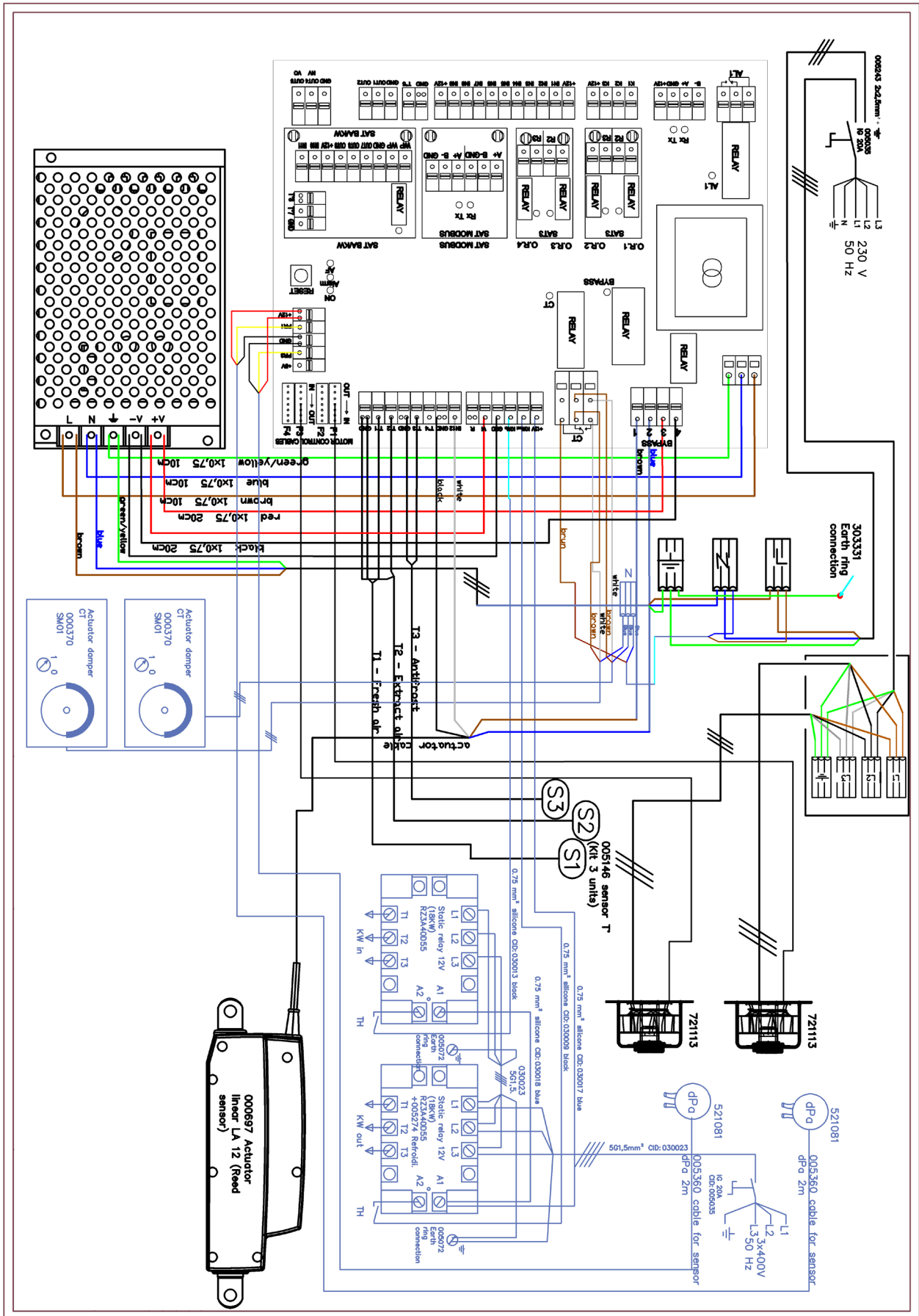

4.4 INTERNAL WIRING DIAGRAM GLOBAL RX (TOP)

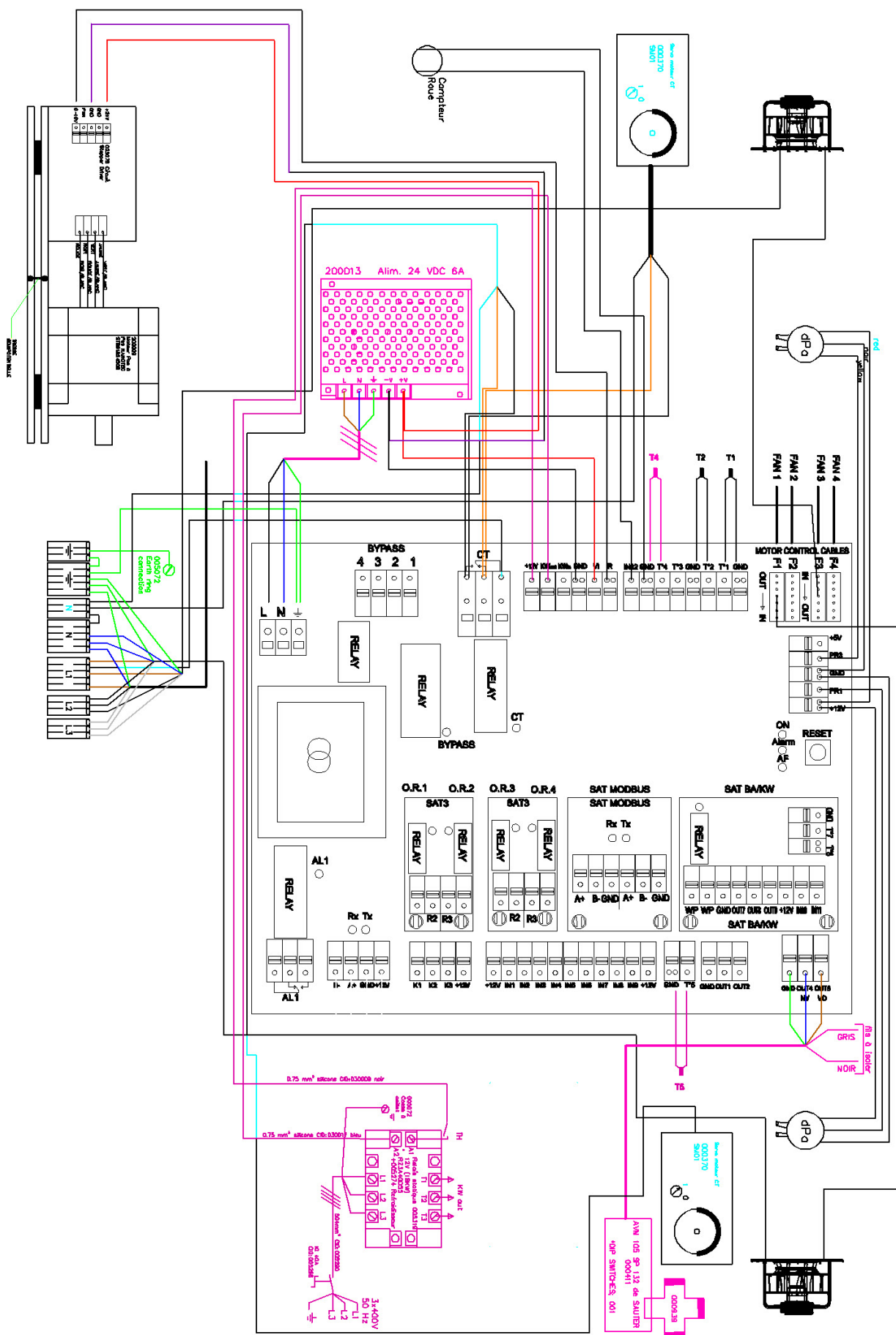

4.5 INTERNAL WIRING DIAGRAM GLOBAL LP^{FW}

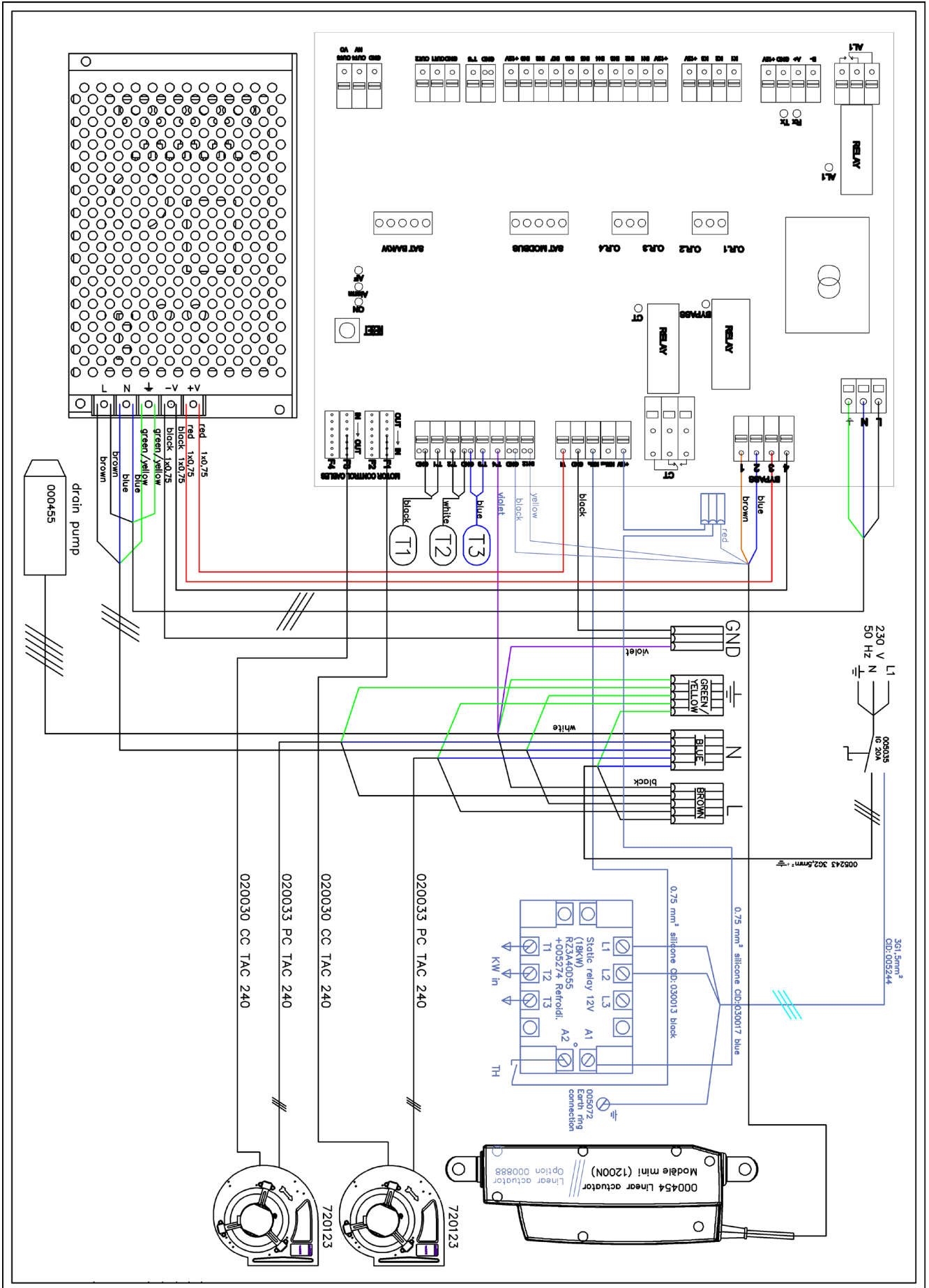

5.0 Functions

5.1 OPERATING MODE

There are five main operating modes. The operating mode determines how the airflow or the fan torque is modulated. The default operating mode is Airflow control. Exceptions are units equipped with backwards fans without the Constant Air Kit or if Constant Torque mode has been selected in the product setup menu, in both cases it is the fan torque that will be controlled and modulated.

In all the operating modes, the supply fan(s) will operate as per the assigned mode and parameters. The exhaust fan(s) will operate according to the chosen percentage of the supply fan (%EXH/SUP ratio). The five main operating modes are:

- 1 - Airflow control:**
Flow control involves operating the air handling unit to keep the pre-set airflow constant. The speed of the fans is automatically regulated to provide correct airflow even if the filters begin to become clogged, air terminals are blocked, etc. Airflow control mode is advantageous, since the airflow always is exactly as it was from the beginning. It should however be noted that everything that increases the pressure drop in the ventilation system, such as blocking of air terminals and dust accumulating in filters, causes the fans to run at a higher speed. This results in higher power consumption and may also cause discomfort in the form of noise. There are three airflow setpoints to be configured by the user (m³h K1, m³h K2, m³h K3).
- 2 - Torque control:**
3 torque setpoints to be configured by the user (%TQ K1, %TQ K2, %TQ K3). The setpoint is configured in % of the maximal torque. The torque control allows to vary the fan speed automatically, to provide a variable airflow for demand controlled systems (DCV). This allows for demand controlled fan operation or fan optimisation by a BMS system, mostly used in multi zone systems. This operation mode can partially replace the constant pressure control when a duct pressure sensor hasn't been installed.
- 3 - Demand control 0-10V:**
The airflow is controlled by a 0-10 V signal. The control signal is connected to terminals K2&GND. The assigned supply airflow is set as a percentage of a linear 0-10 V signal. The user defines the link with 4 parameters: Vmin, Vmax, m³h≡Vmin and m³h≡Vmax, applied to the following diagram. The demand control mode is also available for modulating fan torque instead of airflow (relevant for backwards fans units without Kit CA). The principle is identical to the demand control mode operation with the difference that Vmin and Vmax are connected to a %TQ instead of m³/h.
- 4 - Pressure control:**
The airflow automatically varies to provide constant pressure in the ducting system. This type of control is also called VAV control (Variable Air Volume).

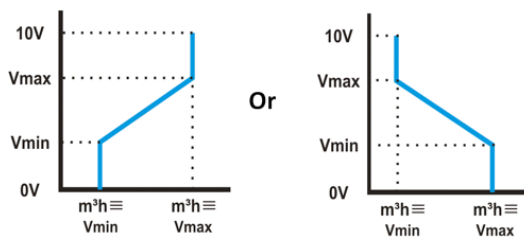

Pressure on supply: the airflow of the supply fan(s) is modulated to maintain a certain pressure Setting constant. The pressure is measured by a pressure sensor located in the supply air duct.

Pressure on exhaust: the airflow of the exhaust fan(s) is modulated to maintain a certain pressure Setting constant. The pressure is measured by a pressure sensor located in the extract air duct.

- 5 - MODE OFF :**
This stops the AHU

5.2 TEMPERATURE CONTROL

There are several options available on GLOBAL units to ensure a comfortable temperature. The options are controlled either via supply or extract air temperature.

Supply Air Temperature

Supply temperature control is the default setting. This involves keeping a constant supply air temperature without consideration to the load in the premises. The supply air temperature is measured on sensor T5.

Extract Air Temperature

The default temperature control can be changed to Extract temperature control via the advanced setup. The extract air temperature is measured on sensor T2. Extract air control involves keeping a constant temperature in the extract air duct (premises), by controlling the supply air temperature. This provides a uniform temperature in the premises regardless of the load. The internal sensor T2 can be replaced with the optional external room temperature sensor (CID370042).

Temperature sensor positioning :

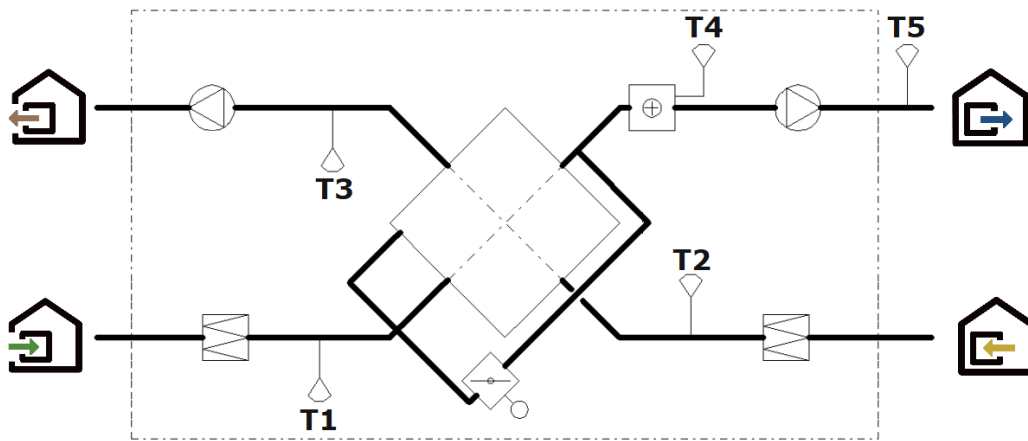

5.3 FREE COOLING (RX AND PX)

The free cooling function uses the lower temperature of the outside air to cool the building.

Free cooling is realized by means of the integrated 100% modulating bypass of the heat exchanger (PX) or the stepless motor control of the rotary heat exchanger (RX). The optional output O.R.4 on the SAT3 relay indicates the position of the bypass. The contact will open if the bypass is fully closed, or close if the bypass is fully or partially open.

The bypass (PX) or the rotary heat exchanger (RX) can be configured as on/off or modulating. This is configured in ADVANCED SETUP. In modulating mode, the temperature is configured in the base setup and the position of the bypass/stepless motor will modulate in order to maintain the setpoint. The free cooling function is activated automatically. An on/off bypass/stepless motor operates according to the logic below:

Free cooling STARTS if the following conditions are TRUE :

- The outdoor temperature (sensor T1) is lower than the extract air temperature (sensor T2)
- The outdoor temperature (sensor T1) is higher than 15°C.
- The extract air temperature (sensor T2) is higher than 22°C.

Free cooling STOPS if one of the following conditions is TRUE :

- The outdoor temperature (sensor T1) is higher than the extract air temperature (sensor T2).
- The outdoor temperature (sensor T1) is lower than 14°C.
- The extract air temperature (sensor T2) is lower than 20°C.

These Settings can be configured in ADVANCED SETUP

5.4 COOLING RECOVERY

The cooling recovery function uses the lower extract air temperature to cool down the fresh air. The function is not configurable. If there is a cooling load in the building and the temperature in the extract air is lower than the outdoor air temperature, the heat exchanger shall be automatically controlled to operate at maximal speed (RX only) or the bypass shall be controlled as closed (PX units). The temperature setpoint is configured in the base setup and the cooling recovery operates according to the logic below:

Cooling recovery STARTS if the following condition is TRUE :

- The outdoor temperature (sensor T1) is higher than the extract air temperature (sensor T2).

5.5 CHANGE OVER FUNCTION

4 PIPE AUTOMATIC CHANGE OVER

The TAC5 controller allows for the control of reversible coil or both cooling and heating coil. The coils are equipped with their motorised 3-way valves. The offset between the measured temperature (supply air or extract air, to be configured) and the setpoint will determine if heating or cooling is automatically activated. When the unit is equipped with reversible coil or with both a cooling and a heating coil, only one setpoint has to be configured: Comfort temperature. The neutral band prevents the cooling and heating systems from counteracting each other. The neutral band is added to the comfort setpoint for the activation of the cooling function. The neutral bands has to be configured in the advanced setup.

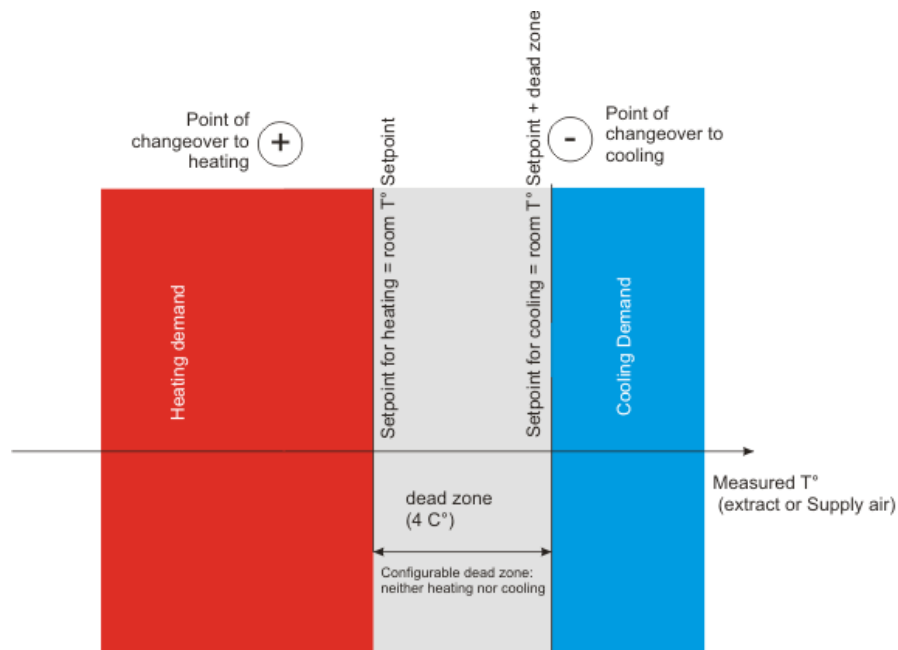

5.6 FROST PROTECTION

HEATING COIL

The frost protection function is always active if the heating coil has been correctly configured in the product setup. The monitoring function uses the temperature sensor T4 for the integrated coil (IBA) or the temperature sensor T7 for the external coil (EBA). The function is

activated when the surface temperature of the coil drops below 5°C. Under these conditions the pump output is activated and the three-way valve output will be 100%. If after 15 minutes the surface temperature has not risen, the unit will shut down and generate a frost alarm.

PLATE HEAT EXCHANGER (PX)

There are three strategies to protect the plate heat exchanger from freezing :

- **1 - Reduced supply air flow :**
The heat exchanger is supplied with a frost protection sensor on the exhaust air (T3). If the exhaust air temperature (T3) is $>+1^{\circ}\text{C}$ and $<+5^{\circ}\text{C}$:
 - In airflow control mode and demand control, the supply air flow will modulate between 100% and 33% (AFlow) of the setpoint (AFn)
 - In pressure control mode, the supply air pressure will modulate between 100% and 50% (AFlow) of the setpoint (AFn)If the exhaust air temperature (T3) is $<1^{\circ}\text{C}$, the supply air fans will stop until the exhaust air temperature (T3) is $>2^{\circ}\text{C}$ for 5 minutes.
- **2 - Modulating bypass :**
The modulating bypass is controlled by the exhaust temperature sensor (T3). If:
 - Exhaust temperature (T3) $>+1^{\circ}\text{C}$: bypass closed or controlled by free cooling function
 - Exhaust temperature (T3) $\leq +1^{\circ}\text{C}$: bypass will modulate for the exhaust temperature (T3) to exceed $+1^{\circ}\text{C}$.
The corresponding supply air temperature will drop due to a lower airflow through the heat exchanger
- **3 - Electrical preheating coil (accessory) :**
If an electrical pre-heating coil (KWin) is installed and configured, the pre-heating coil (KWin) will modulate so the exhaust temperature is $+1^{\circ}\text{C}$.
- **4 - Differential pressure measurement (Cold climate option) :**
For cold climate conditions ($\geq -20^{\circ}\text{C}$), the unit is equipped with a differential pressure sensor mounted on the heat exchanger. The pressure sensor detects when the pressure drop, due to frost, has become too high. In critical conditions, the supply air flow will be paused for a short time, to allow for defrosting.
The frost protection strategy (down regulation supply airflow, modulating bypass or electrical pre-heating) will still be used as a first step. The defrost function will only be active if the frost protection strategy is not sufficient.

These Settings can be configured in ADVANCED SETUP

ROTARY HEAT EXCHANGER (RX)

In order to protect the rotary heat exchanger from freezing, the strategy for frost protection consists of modulating the speed of the rotating heat exchanger, which is linked to the outdoor air temperature (sensor T1).

If the outdoor air temperature $< T^{\circ}\text{AF}$ (default -9°C): the rotation speed of the heat exchanger is reduced to avoid the risk of icing. To exit this anti-frost protection: $T^{\circ}(\text{T1}) \geq T^{\circ}\text{AF}$ for 5 minutes.

These Settings can be configured in ADVANCED SETUP.

5.7 TIME SCHEDULE

The controller allows 6 time slots (channels) to be configured. For each day of the week, the operation mode can be either AUTO (operate according to time slots) or OFF.

For each time slot select :

- In airflow control mode: the airflow by selecting m^3/h K1/ m^3/h K2/ m^3/h K3/OFF (stop)
- In torque control mode: the torque by selecting %TQ K1/%TQ K2/%TQ K3/OFF (stop)
- In demand control mode :
 - with only one 0-10 V signal (default) or with 2 signals to control the supply airflow: the link LS (percentage of the nominal link, cfr $\text{m}^3/\text{h} \equiv V_{\text{min}}$ and $\text{m}^3/\text{h} \equiv V_{\text{max}}$ in setup OR cfr %TQ $\equiv V_{\text{min}}$ and %TQ $\equiv V_{\text{max}}$ in setup) and the rate of the exhaust airflow by the supply airflow.
 - with one 0-10 V signal for supply and one 0-10 V signal for exhaust (via advanced setup): one link LS (percentage of the nominal link) for supply and one for exhaust.
- In pressure control mode :
 - Constant pressure on supply or exhaust: the pressure setpoint (percentage of the nominal setpoint) and the rate of the exhaust airflow by the supply airflow.
 - Constant pressure on supply and exhaust: one pressure setpoint (percentage of the nominal setpoint) for supply and one for exhaust.

6.0 Commissioning

As a human machine interface (HMI), several options are available. The HMI will enable access to the control parameters in the integrated controller. The HMI as such does not contain any programming and therefore is not mandatory.

The possible HMIs are:

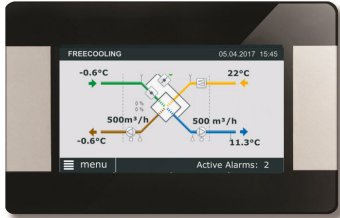

TACtouch touchscreen - CID372096

This 4.3" touchscreen display is used when there is a need for a graphical HMI. The Touchscreen touchscreen is a complete graphic monitoring system where the screens are designed to be intuitive and complete, ensuring a userfriendly experience.



Position switch (COM4) - CID010007

The most basic interface to control a GLOBAL air handling unit is the 4 position switch. This switch will allow to control the unit to its three configured airflow (low, medium and high) and as a fourth position, the unit is switched off.

6.1 COMMISSIONING WITH TACtouch INTERFACE

The hand-held terminal consists of a 4.3" touch screen with a 1,5 metre long cable for connection to the air handling unit 's control circuit board.

If the hand-held terminal is not used for 20 minutes, it switches over to the sleep mode.

The Touchscreen controller can be used outdoors, but it must be kept at a weatherproof place.

Data:

Operating temperature:	0... + 50°C
Maximum length of the cable:	>100 metres
Protection class:	IP20
Dimensions [mm]:	96,8x148,8x14,5
Power consumption:	120mA

IMAGE MANAGEMENT

Start-up image



At the first start up, the basic setup menu will be activated automatically. See section 6.1.3

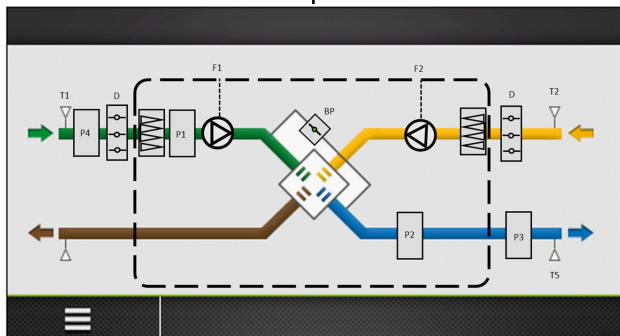
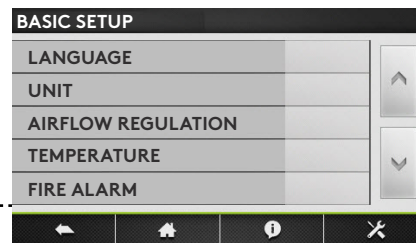

Home Screen. See Section 6.1.1.

By default, the home screen will be shown if no other menu is opened by the user or if selected in the main menu.

N.B.! The appearance of the image varies depending on the type of air handling unit and functions selected.

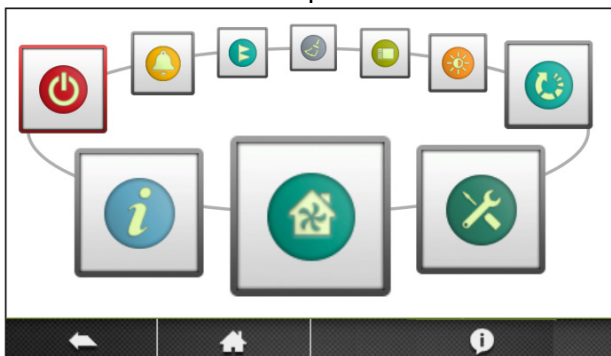

Main menu. See Section 6.1.2.

The main menu is presented as a rotary menu. After pressing the "menu"-button at the bottom left corner of the Home Screen, the rotary menu will be shown.

6.1.1 HOME SCREEN

The home screen displays the current key data for the air handling unit and is normally displayed if no other menu has been selected or if selected from the main menu. The touch screen switches to the sleep mode after 20 minutes. To leave the sleep mode, press on the touchscreen.

On the main screen, the fields are:

- Current operation mode
The operation modes are: STOP, Heating, Cooling, Post ventilation, Freecooling, Frost protection.
- Current date and time
- Active alarms
This fields shows the number of current alarms. By clicking on this field, more detailed information about the different alarms is available
- Menu
Accessing the main menu, see section 6.1.2
- Flow Chart
The flow chart is not editable by the user, the configuration of the activated options and functions is done through the product setup (menu). A code and a special training are desired for access to this menu. The appearance of the image varies depending on the type of air handling unit and its selected functions and/or options. Flow chart symbols:

Current operation status

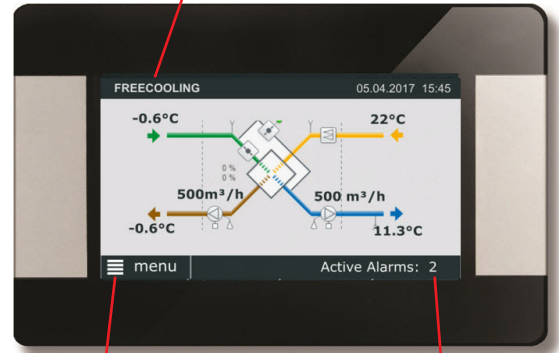

Main menu button

Number of current alarms



Bypass (closed/open)



Electrical heating coil



Water heating coil



Change over coil



Cooling coil



Motorised damper (open/closed/opening)

Flow charts:



Plate heat exchanger

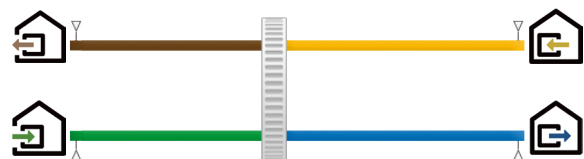

Rotary heat exchanger

6.1.2 Main menu

The main menu consists of a rotary menu with 7 icons.

Control

The control menu will allow for the user to change basic parameters and operation status of the unit.

The unit can be switched on/off

The fan speed can be selected; three manual speeds + one auto speed

Post heating, post cooling and free cooling setpoints can be changed.

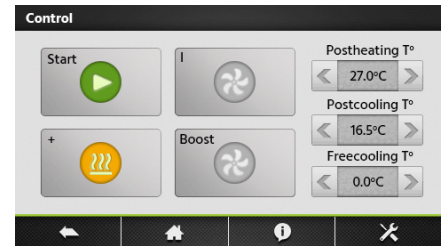

Alarm

Alarms are displayed on the main screen of the HMI. Active alarms can be viewed in this menu. All the alarms can be reset.

A fault can be traced by examining the function or functional component indicated in the alarm text. More information about the individual alarms, see section 8.0

If the fault cannot be immediately remedied:

Consider whether the air handling unit can continue to operate until the fault has been remedied.

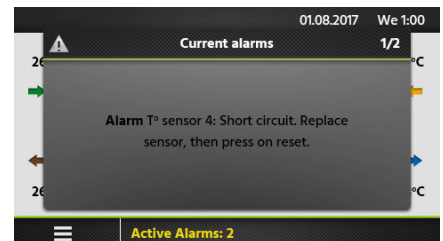

Time schedule

The built-in timer enables you to control the AHU's operating mode/time. Certain other oversteering functions such as external timer, communication, etc. affect the preset operating modes. The controller allows 6 time slots (channels) to be configured.

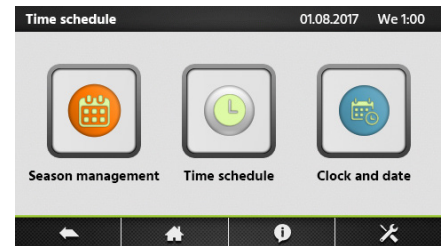

Time and date

The current date and time can be set and adjusted if needed. The timer automatically takes leap years into consideration. The system is preset for automatic changeover between summer time/winter time according to EU Standard.

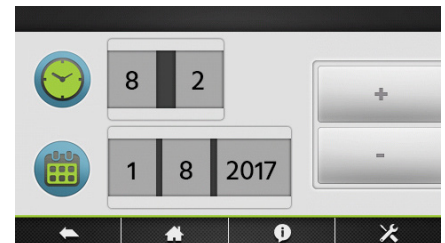

Time schedule

Times and days can be set when the air handling unit is to run in the high speed mode, medium speed mode, low speed mode or be switched off. For each day (Monday - Sunday), six different time slots can be configured. The time slots are subsequent.

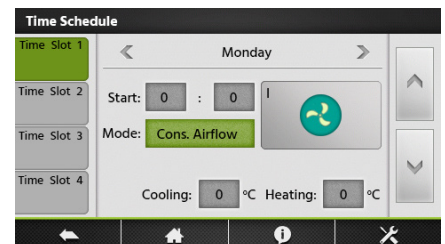

Seasonal management

The seasonal management menu allows for the deactivation of heating coils, cooling coils and bypass freecooling function based upon a year calendar. In between the programmed interval, the selected function is OFF.

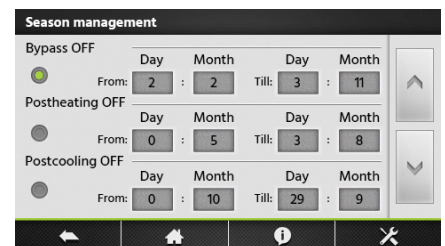

Basic Setup

The basic setup menu will guide the user through the most critical settings of the air handling unit. This setup procedure is described in detail, section 6.1.3



Readings

The operating status and the Settings can be read. Used for performance checks and for generally checking Settings, settings, power consumption, etc. No Settings can be altered in this menu group.

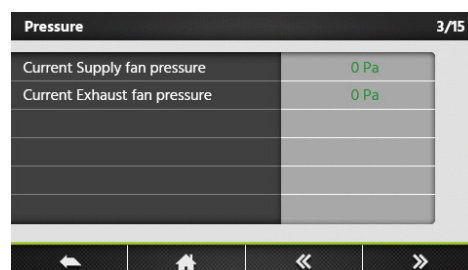

Maintenance

Configuration of service related settings. A maintenance warning interval can be configured as well as the filter clogging alarm.

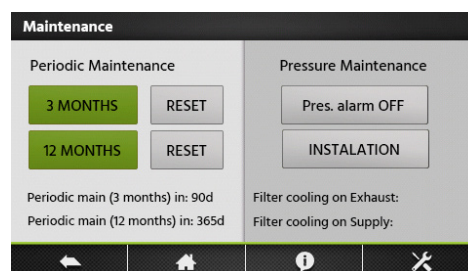

Advanced setup

A code and a special training are desired for access to this menu.



6.1.3 BASIC SETUP

When the air handling unit is started up for the first time, the commissioning menu is automatically displayed. At the very end of the commissioning (menu) the commissioning of the unit has to be confirmed by the service technician. Once the commissioning has been confirmed, the commissioning menu will not be displayed as first menu any more. The commissioning menu, however, will remain accessible through the advanced setup. See Section 6.1.4.

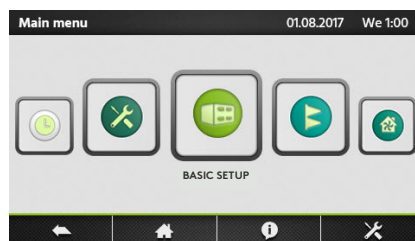

Language

The language desired can be set here. The language setting can be changed at any time in the basic setup menu.

Setting	Settings range	Factory setting
Language	Languages as displayed	English

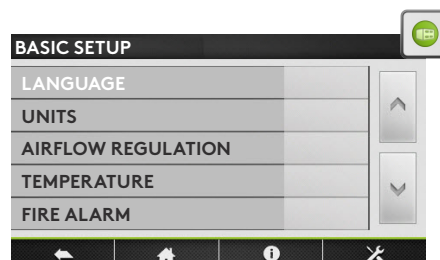

Units

The desired unit can be set here. The unit setting can be changed at any time in the basic setup menu.

Setting	Settings range	Factory setting
Unit	m ³ /h l/s	m ³ /h

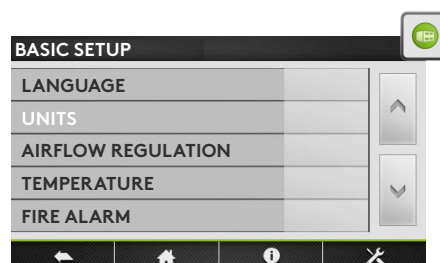

Airflow regulation

The desired control mode can be set here. The setting can be changed at any time in the basic setup menu. Depending on the selected function, flows can be set as (l/s, m³/h), pressure (Pa), input signal strength (%) or torque (%). For both "Airflow control" and "Torque control", three setpoints are available: Low, medium and high.

Setting	Settings range	Factory setting
Operating mode	OFF Airflow Demand control Pressure Torque	Airflow

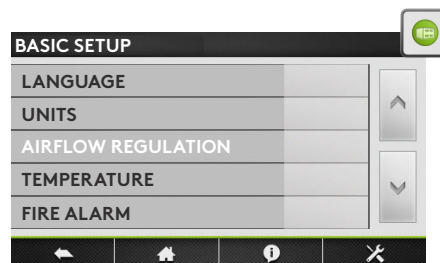

Constant airflow

Flow control involves operating the air handling unit to keep the preset airflow constant. The speed of the fans is automatically regulated to provide correct airflow even if the filters become clogged, diffusers are blocked, etc. The exhaust air fan is controlled as a slave. A ratio between exhaust and supply pressure can be configured in order to create over, under or balanced pressure. For units with backward fans, constant airflow can only be selected if the "constant air kit" has been ordered as an option. The desired setpoint is preset in (l/s, m³/h).

Setting	Range	Factory setting
Airflow K1/K2/K3	0...max	
Ratio exhaust/supply	5...999%	100%
Enable pressure alarm	No Yes	Yes
ΔP Supply/Exhaust for pressure alarm	25...999Pa	200Pa
Initialisation airflow	(l/s, m ³ /h)	
Pressure alarm initialisation	No Yes	Yes

Torque control

The constant torque operating mode allows to vary the fan speed automatically, to provide a variable airflow for demand controlled systems. This operating mode can partially replace the constant pressure control when a duct pressure sensor hasn't been installed. The exhaust air fan is controlled as a slave. A ratio between exhaust and supply pressure can be configured in order to create over, under or balanced pressure. The desired setpoint is preset in %. The Torque control mode can be deactivated in the advanced setup.

Setting	Range	Factory setting
Airflow K1/K2/K3	0...100%	
Ratio exhaust/supply	5...999%	100%

Demand control

The airflow desired is regulated in response to 0-10 V input signals from an external sensor, such as a carbon dioxide or a humidity sensor. The function can be configured with a positive or a negative logic. A ratio between exhaust and supply pressure can be configured in order to create over, under or balanced pressure. The desired setpoint is preset in (l/s, m³/h). The "sleep factor" is a lower operating rate for the unit (due to e.g. low occupancy) that will be activated by speed "III "

Setting	Range	Factory setting
Vmin	0...10V	1,0V
Vmax	0...10V	10,0V
m ³ /h ~Vmin	(l/s, m ³ /h)	
m ³ /h ~Vmax	(l/s, m ³ /h)	
Ratio exhaust/supply	5...999%	100%
Sleep factor on K3	10...100%	100%
Enable pressure alarm	No Yes	Yes
ΔP Supply/Exhaust for pressure alarm	10...999Pa	200Pa
Initialisation airflow	(l/s, m ³ /h)	
Pressure alarm initialisation	No Yes	Yes

Constant pressure

The airflow automatically varies to provide constant pressure in the ducting. The duct pressure is measured by an external in-duct pressure sensor which is connected to the control unit's BUS communication or the an analogue 0...10V input. The function can be configured on supply air, extract air or supply and extract air. The first two configurations will have the second set of fans be controlled as a slave. A ratio between exhaust and supply pressure can be configured in order to create over, under or balanced pressure. The initialisation will allow for an automatic calculated pressure setpoint, determined by the nominal airflow. The "sleep factor" is a lower operating rate for the unit (due to e.g. low occupancy) that will be activated by speed "III "

Setting	Range	Factory setting
Control	Supply Exhaust Supply+Exhaust	Supply
Ratio exhaust/supply	5...999%	100%
Sleep factor on K3	10...100%	100%
Pressure initialisation	Via Airflow Via Pressure	Airflow
Start reference initialisation	Yes No	Yes

Temperature

The temperature control can be configured as a supply air control or an extract air control. By default, this function is configured as a supply air temperature control. Changes to this configuration are done in the advanced setup; see Section 6.1.4

Setting	Settings range	Factory setting
T° heating	0...45°C	20,0°C
T° Cooling	0...99°C	24,0°C
T° Freecooling	0...99°C	15°C

Fire Alarm

An external fire detection system is used to control the air handling unit in case of emergency. The fire alarm function is activated by means of digital input IN3.

Setting	Settings range	Factory setting
Input	Normally open Normally closed	Normally closed
Supply airflow	0...max	
Extract airflow	0...max	

Periodic maintenance

Built-in timer for maintenance warning; if the maintenance interval is exceeded, a maintenance reminder will be displayed.

Setting	Settings range	Factory setting
3 monthly warning	Yes No	No
12 monthly warning	Yes No	No

Commissioning completed

When the commissioning has been successful and this is confirmed in this menu, the commissioning menu will not be activated automatically anymore.

Setting	Settings range	Factory setting
Confirmation of successful commissioning	Yes No	No

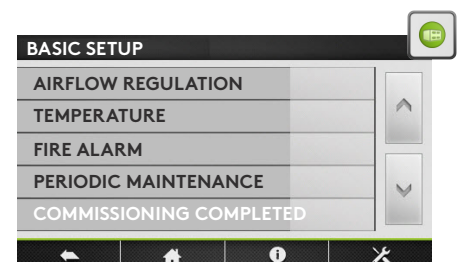
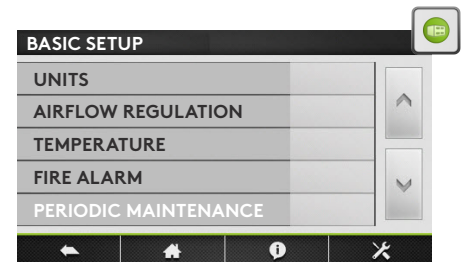
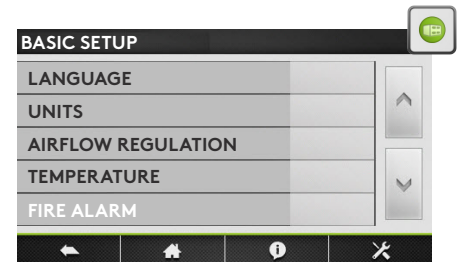
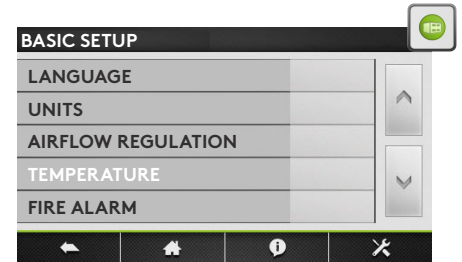

6.1.4 ADVANCED SETUP

N.B.! The appearance and content of this menu varies depending on the type of air handling unit and functions and/or options selected. A code and a special training are needed to access this menu.



Attention: The settings range for most of the functions is defined for maximal flexibility. The factory setting is the advised setting, deviating from this setting requires careful consideration.

Stop fan with 0...10V

Function only available if "demand control" function has been selected in basic setup. With this function, the fans can be stopped if the 0...10V control signal is below or above a specified setpoint. The control signal is connected to the analogue input K2.

Setting	Settings range	Factory setting
Stop if <Vlow	No Yes	Yes
Vlow	0...10V	0,8V
Stop if >Vhigh	No Yes	Yes
Vhigh	0...10V	10,0V

Second 0...10V control signal

Function only available if "demand control" function has been selected in basic setup. With this function, a separate 0...10V control signal for the extract air can be activated. The control signal is connected to the analogue input K3.

Setting	Settings range	Factory setting
0...10V on K3?	No Yes	No
Control	Exhaust Supply	Exhaust

Pressure control

Function only available if "pressure control" function has been selected in basic setup. The reaction speed of the fans for the balancing of the constant pressure system can be modified. A higher Setting will result in a faster reaction speed; a lower Setting will result in a slower reaction speed. The system can be defined as a negative or a positive logic. A negative logic airflow drops when analogue signal on K2 is > than the setpoint.

Setting	Settings range	Factory setting
Reaction speed	0...10	10
Logic	Positive Negative	Negative

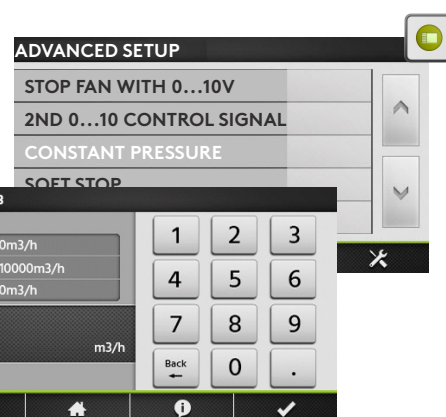
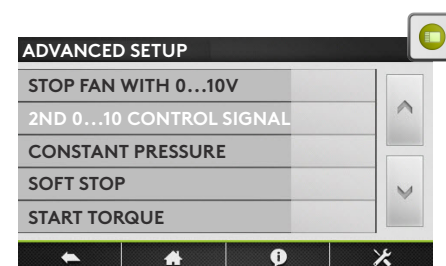
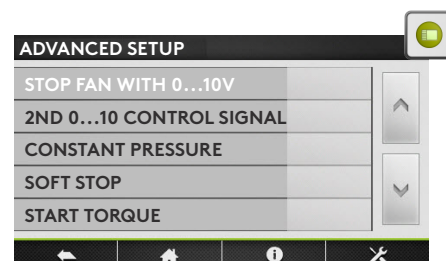
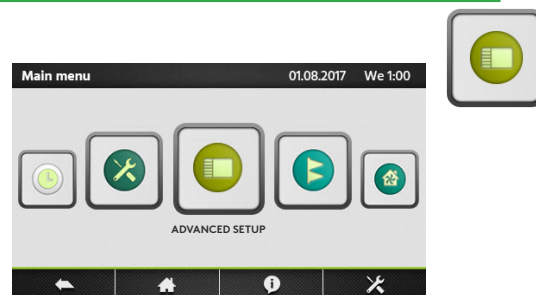

Stop fan when pressure alarm

Possibility to stop the fans automatically in case of a pressure alarm.

Setting	Settings range	Factory setting
Stop fans	No Yes	No

Start torque

Possibility to change the fans's starting torque.

Setting	Settings range	Factory setting
Start Torque	0...100%	2%

Deactivate softstop

With this function, the "OFF" function is deactivated.

Setting	Settings range	Factory setting
Softstop	Yes No	No

Temperature

In this menu advanced temperature control parameters can be modified.

Supply air involves keeping a constant supply air temperature without consideration to the load in the premises.

Extract air involves keeping a constant temperature in the extract air duct (premises), by modulating the supply air temperature.

The reaction speed of capacity control signal can be modified. A higher Setting will result in a smoother control; a lower Setting will result in a faster reaction speed. but also greater risc of oscillations.

Setting	Settings range	Factory setting
Supply or Extract temperature control?	Supply Extract	Supply
Reaction speed	1...10	1
Supply air, min	0...20°C	15,0°C
Supply air, max	16...50°C	28,0°C
Stop fan if T°Supply <5°C	No Yes	No

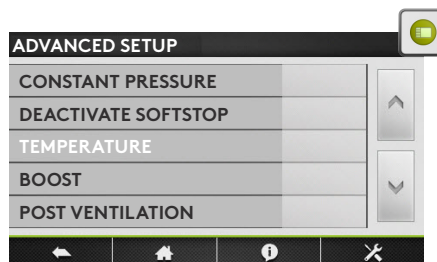
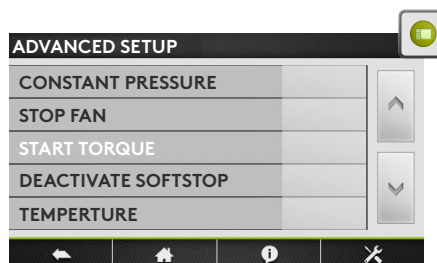
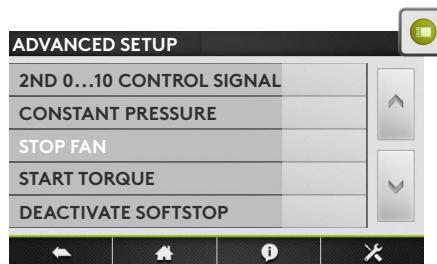

Boost

The boost mode can be used to force the supply and extract airflow to a higher setpoint, when specific conditions are met. The boost mode can be activated with a contact connected to the digital input IN9 or by an analogue 0...10V control signal connected to input K3. The boost setpoint is preset in (l/s, m³/h).

Setting	Settings range	Factory setting
Supply/Extract airflow	0...max	
Boost activation on	Contact RH	Contact
RH on/off	0...100%	60%/40%
Vmin/max RH on K3	0...10V	2,0V/9,5V
RH ~Vmin/max	0...100%	2%/95%

Post ventilation

The post ventilation function is used to keep the fans running during a specified laps of time. This function is activated automatically when an electrical heating coil is activated.

Setting	Settings range	Factory setting
Activation	No Yes	No
Time	0...9999sec	90sec

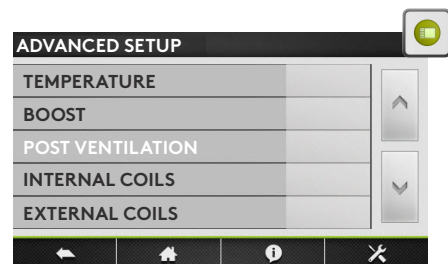
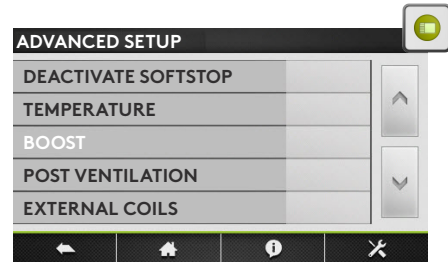

Internal coils

Water preheating coil

By preheating the outdoor air, it is possible to prevent moisture precipitation in the AHU's outdoor air filter, to reduce the risk of frosting in the heat exchanger and to eliminate the risk that pressure sensors and motor control systems are operating in too low ambient temperature. The setpoint is of the exhaust air temperature.

Setting	Settings range	Factory setting
Setpoint	-9,9...99,9°C	1,0°C

Electrical preheating coil

By preheating the outdoor air, it is possible to prevent moisture precipitation in the outdoor air filter of the air handling unit, to reduce the risk of frosting in the heat exchanger and to eliminate the risk that the ambient temperature will drop lower than minimum permissible. The electrical preheating coil is installed and configured in factory. The electrical preheating coil will always have its separate power supply and main switch.

Setting	Settings range	Factory setting
Setpoint	-9,9...99,9°C	1,0°C
PID - Proportional Band	0...100	5
PID - Integral	0...100	30
PID - Derivate	0...100	11

Electrical postheating coil

The electrical postheating coil is installed and configured in factory. The electrical postheating coil will always have its separate power supply and main switch. The capacity of the coil will be controlled proportionally in order to keep a temperature as defined by the selected operating mode.

Setting	Settings range	Factory setting
Control mode	Exhaust Supply	Supply
Setpoint	-9,9...99,9°C	21,0°C
PID - Proportional Band	0...100	5
PID - Integral	0...100	30
PID - Derivate	0...100	11

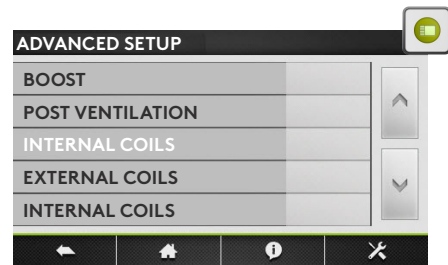

Water postheating coil

The water postheating coil is installed and configured in factory. The 3-way valve is not installed and will have to be installed and wired on site. The capacity of the coil will be controlled proportionally in order to keep a temperature as defined by the selected operating mode. The output O.R.3 on the optional "SAT3" output relay, is activated whenever heating is desired.

Setting	Settings range	Factory setting
Control mode	Exhaust Supply	Supply
Setpoint	-9,9...99,9°C	21,0°C
Reaction Speed	1...10	5

External coils

Configuration of the coils

This menu will allow for the configuration of any combination of external heating and or cooling coil(s).

Setting	Settings range	Factory setting
Type	None Hot water Cold water Hot & Cold water Reversible water Electric PWM Electric PWM + Cold water Water preheating Water preheating+postheating Water preheating+reversible Electric 0...10V Electric 0...10V + Cold water	None

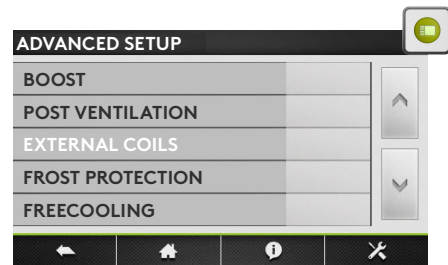

Water post heating

The external post heating coil is delivered separately from the air handling unit and will not be pre configured in factory. Both the coil and the 3-way valve will have to be installed and wired on site. The capacity of the coil will be controlled proportionally in order to keep a temperature as defined by the selected operating mode. The reaction speed can be set. A higher Setting will result in a faster reaction speed; a lower Setting will result in a slower reaction speed.

Setting	Settings range	Factory setting
Control mode	Exhaust Supply	Supply
Setpoint	0...99,9°C	21,0°C
Reaction Speed	1...10	5

Water cooling coil

The external post cooling coil is delivered separately from the air handling unit and will not be pre configured in factory. Both the coil and the 3-way valve will have to be installed and wired on site. The capacity of the coil will be controlled proportionally in order to keep a temperature as defined by the selected operating mode.

Setting	Settings range	Factory setting
Control mode	Exhaust Supply	Supply
Setpoint	0...99°C	17,0°C
Reaction Speed	1...10	5

Electrical postheating coil

The external post heating coil is delivered separately from the air handling unit and will not be pre configured in factory. The coil will have to be installed and wired on site. The capacity of the coil will be controlled proportionally in order to keep a temperature as defined by the selected operating mode.

Setting	Settings range	Factory setting
Control mode	Exhaust Supply	Supply
Setpoint	0...+99°C	21,0°C
PID - Proportional Band	0...100	5
PID - Integral	0...100	30
PID - derivate	0...100	11

Combi coil

The external change over coil is delivered separately from the air handling unit and will not be pre configured in factory. The coil will have to be installed and wired on site. The capacity of the coil will be controlled proportionally in order to keep a temperature as defined by the selected operating mode.

Setting	Settings range	Factory setting
Activate change over	No Yes	No
Neutral band High	0...+50°C	4K
Neutral band Low	0...+50°C	2K

Frost protection

Frost protection plate heat exchangers (PX)

In environments where the extract air can occasionally be humid, the defrosting function can be activated to protect the heat exchanger from frosting. There are four strategies: down control of the supply air volume, modulating by-pass control, modulation of capacity of a pre-heating coil, differential pressure measurement (cold climate option). If non of these measures are effective, the air handling unit can be stopped by limiting the minimal supply air temperature. When the Frost protection cycle is active, it will be indicated on the HMI. The configurable temperatures are outdoor temperatures.

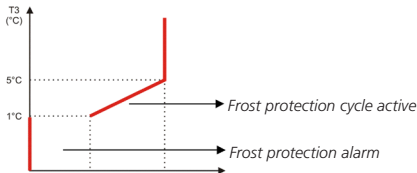

Setting	Settings range	Factory setting
T° Low	1...3°C	+1,0°C
T° High	1...5°C	+5,0°C
Stop supply airflow	No	Yes

Frost protection rotary heat exchangers (RX)

In environments where the extract air can occasionally be humid, the defrosting function can be activated to protect the heat exchanger from frosting. The speed of the rotating heat exchanger is linked to the temperature of the supply (sensor T1). When the Frost protection cycle is active, it will be indicated on the HMI.

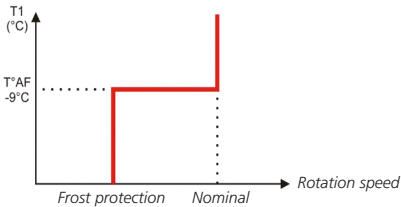

Setting	Settings range	Factory setting
Activate Frost protection	-10...+99°C	-9°C
RX rotation speed	2...10RPM	2RPM

Frost protection heating and cooling coils

The water coils are always protected against freezing by an anti-frost temperature sensor. This sensor is mounted on the surface of the water coil. When the anti-frost protection temperature of the hydraulic coil detects a temperature lower than 4°C (default), the pump contact is closed and the 3 way valve is opened 100% during 15 minutes. If the unit is running, the alarm is activated immediately. For a water preheating coil, the frost alarm is delayed by 2 minutes. If frost protection conditions occur when the air handling unit is OFF, the alarm is delayed by 5 minutes.

Setting	Settings range	Factory setting
Internal heating coil	-10...+10°C	+4,0°C
External heating coil	-10...+10°C	+4,0°C
External cooling coil	-10...+10°C	+4,0°C
Internal preheating coil	-10...+10°C	+4,0°C

Freecooling

The bypass on the GLOBAL product range, can be configured for freecooling. The main parameters to activate the free cooling function are the outside temperature (T1) and the extract (room) air temperature (T2). When there is maximal freecooling possibility the bypass will be 100% open. The 100% opened bypass can activate the configurable freecooling airflow.

Setting	Settings range	Factory setting
Outdoor T°	0...27°C	0,0°C
Extract/Room T°	6...28°C	22,0°C
Supply airflow	(l/s, m³/h)	
Extract airflow	(l/s, m³/h)	
Bypass control	Frost protection Freecooling Frost protection & free cooling	Freecooling

0-10V output

The controller has as a standard feature two configurable analogue 0...10V outputs. The outputs represent the actual airflow (or torque) or the actual pressure delivered by one of the selected fans.

Setting	Settings range	Factory setting
Output 1	Flow Fan 1	Flow Fan 1
	Pressure Fan 1	
	Flow Fan 2	
	Pressure Fan 2	
	Flow Fan 3	
	Pressure Fan 3	
	Flow Fan 4	
	Pressure Fan 4	
	Torque Fan 1	
	Torque Fan 2	
	Torque Fan 3	
	Torque Fan 4	
Output 2	Flow Fan 1	Pressure Fan 1
	Pressure Fan 1	
	Flow Fan 2	
	Pressure Fan 2	
	Flow Fan 3	
	Pressure Fan 3	
	Flow Fan 4	
	Pressure Fan 4	
	Torque Fan 1	
	Torque Fan 2	
	Torque Fan 3	
	Torque Fan 4	

Modbus configuration

The MODBUS RTU communication requires an additional satellite circuit (CID050043) which is used as communication interface. The communication protocol used is MODBUS RTU, RS485.

Setting	Settings range	Factory setting
Adress	1...247	1
Baudrate	1200	9600
	4800	
	9600	
	19200	
Parity	No	No
	Yes	

LAN configuration

The MODBUS TCP/IP communication requires an additional satellite circuit (CID 025072) which is used as communication interface. The communication protocol used is Modbus TCP/IP on Ethernet network over twisted pair 10 BASE T/100Base-TX IEEE 802.3.

Setting	Settings range	Factory setting
IP configuration	DHCP	Manual
	Manual	
IP adress		192.168.1.1
Netmask		255.255.255.0
Gatway		0.0.0.0

Operating time

For maintenance purposes, operating timers can be activated. If the "service alarm time" or the "Stop fan" timers are triggered, the according alarm will be shown and the unit will switch to "OFF"-mode.

Setting	Settings range	Factory setting
Reset timer	No	No
	Yes	
Fan run time activation	No	No
	Yes	
Display time	No	No
	Yes	
Service alarm time	0...999999h	0h
Stop fan	0...999999h	0h

7.0 Preventive maintenance



Attention : before handling and/or opening the access panels it is compulsory to shut down the unit and disconnect the power supply using the general switch located on the front panel.
Do not isolate the power supply whilst the unit is running. If KWin and/or KWout are installed, then isolate the corresponding power supplies.

Regular maintenance is essential to guarantee good operation of the air handling unit and a long service life. The maintenance frequency will depend on the application and on the actual environment conditions but the following are general guidelines:

7.1 ONCE THE UNIT OPERATES IN NORMAL CONDITION

Replace the filters with a kit of replacement filters.

7.2 EVERY 3 MONTHS

- Check for any alarms indicated on the control device. In case of an alarm refer to troubleshooting section.
- Check the state of filter clogging. The control device allows a pre-defined 'filter alarm' threshold to be set. Replace filters if necessary. Filters that are too clogged can generate the following problems:
 - Insufficient ventilation
 - Excessive increase of fan rotation speed
 - Excessive sound levels
 - Excessive power consumption (power consumption will increase exponentially to an increase in pressure drop, for a constant airflow)
 - Unfiltered air passing through the heat exchanger (risk of clogging) and into ventilated rooms.

The list of replacement filter kits for each unit can be downloaded from our website.

- Inspection and cleaning of the inside of the unit:
 - Vacuum clean any accumulations of dust in the unit.
 - Inspect and gently vacuum clean the heat exchanger if necessary. Use a brush to protect the fins.
 - Clean any condensation stains
 - For PX units, clean any accumulations in the drain pan.

7.3 EVERY 12 MONTHS

1. For rotary heat exchanger (RX) units, check the brush seals on the rotary heat exchanger along the perimeter in contact with the frame:

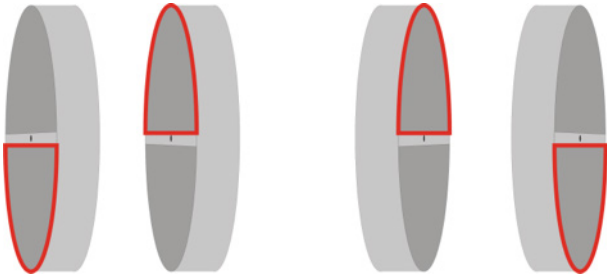

If necessary, bring the brush seals closer to the exchanger to ensure good sealing.

2. For RX units, check the tension of the driving belt on the rotating heat exchanger. If there is no tension or if the belt is damaged, please, contact the service department for a belt replacement.

Ideally the heat exchanger should be cleaned using vacuum cleaner with a soft nozzle to prevent damaging the air passages in the rotor. Turn the rotor by hand to enable you to vacuum clean its entire surface. If the heat exchanger is substantially fouled, it can be blown clean with compressed air.

3. For plate heat exchanger (PX) units:

- Clean the drain pan
- Clean the inside of the bypass. To access the interior of the bypass it is necessary to force it open, proceed as follows: place a jumper between terminals IN4 and +12V on the TAC5 circuit board. The bypass is now open, regardless of the temperature conditions.
- Remember to remove the jumper between terminals IN4 and +12V once cleaning of bypass is done.
- Always clean against the direction of the airflow.
- Cleaning must only be done by blowing with compressed air, vacuum cleaning with a soft nozzle or through wet cleaning with water and/or solvent. Before you begin cleaning, cover adjacent functional sections to protect them. If cleaning solvent is used, do not use solvent that will corrode aluminium or copper.

4. Fan maintenance:

Check again whether the power supply is shut down and fans are not running.

Inspect and clean the fan impellers to remove any dirt deposits, be careful not to alter the impeller balance (do not remove balancing clips). Check the impeller to make sure that it is not out of balance. Clean or brush off the fan motor. It can also be cleaned by carefully wiping it with a damp cloth that has been dipped in a solution of water and detergent. Clean the fan space, if needed. Remove the fans if necessary.

5. Check seals on the unit:

Ensure that the side access panels are fully closed and that the seals are intact. Replace if necessary.

8.0 Troubleshooting

The TAC5 control board generates and reports 18 types of alarms.

The alarms are subdivided into auto resetting and non-auto resetting alarms. For the latter, a reset will be necessary once the problem has been resolved.

For each type of alarm, a full text description will be displayed on the user interface depending on the alarm type:

- Activation of contact relay (NC or NO contact) - AL1
- Activation of SAT3 OR1 in case of pressure alarm, provided that the optional module SAT 3 is installed on the control board.
- "Alarm", "Pa" and "AF" activated LED's on control board
- Alarm on user interface.
- Alarm communication with networking modules provided that an optional communication module (Modbus RTU, MODBUS TCP/IP, and KNX) is installed on the TAC5 control board.

8.1 TYPE 1: ALARM INDICATING A FAN FAILURE

- Conditions:
- Causes:
 - Failure of fan Fx. This problem is usually caused by the fan motor.
If not, the failure may be caused by an internal cable (control or power) or by the TAC5 circuit.
- Effects:

Displayed on HMI TACtouch			
	Text displayed	LED ALARM	LED Pa
B.11	Fan 1 failure	RED	/
B.12	Fan 2 failure		
B.13	Fan 3 failure		
B.14	Fan 4 failure		

TAC5 control board				
AL1 relay	O.R.1	LED ALARM	LED AF	Fans
Alarm	/	ON	/	stopped
Auto reset: yes				

8.2 TYPE 2: ALARM ON THE PRESSURE VARIATION

- Conditions:

- Mode airflow control or demand control. Unit must have forward fans or backward fans with kit CA.
- External pressostat connected on IN2 input

- Causes:

- Pressure alarm setup in airflow control or demand control mode
- External pressostat connected on IN2 input has triggered

- Effects:

Displayed on HMI TACtouch			
	Text displayed	LED ALARM	LED Pa
P.10	Pressure alarm - Supply air	/	RED
P.20	Pressure alarm - Extract air		
S.40	Pressure alarm from Pressure Switch*		

TAC5 control board				
AL1 relay	O.R.1	LED ALARM	LED AF	Fans
/	Closed	ON	/	Run*
Auto reset: yes				

* unless the status has been changed in advanced setup

8.3 TYPE 3: ALARM REPORT DURING REFERENCE PRESSURE INITIALIZATION

- Conditions:

- Mode Airflow control or Demand control: during the initialization of the pressure alarm. In this case, the unit must have forward fans or backward fans with kit CA.
- Mode Pressure control: during the initialization of the pressure reference via airflow

- Causes:

The reference pressure (P_{ref}) cannot be identified and the fans are stopped. 4 possibilities:

1. Actual airflow < requested airflow: The requested working point is 'too high' (too high pressure loss) for the maximal available pressure at the requested airflow for this fan.
2. Actual airflow > requested airflow: the nominal airflow requested to initialize the pressure alarm cannot be reached because the lower limit of the fan's operating zone has been reached.
3. Very unstable pressure (pumping).
4. Assigned airflow not reached after 3 minutes.

If this occurs during initializing an alarm pressure, there are 2 options:

1. No action is taken: the control will operate without a pressure alarm.
2. Corrective action is taken (change the working point to one located in the working zone of the fan, by reducing the pressure system, modifying the nominal airflow...) and restart the setup operation.

If this occurs during initializing of the assignment pressure in pressure control mode: Corrective action must be taken (change the working point to one located in the working zone of the fan, by reducing the pressure system, modifying the nominal airflow ...) and restart the setup operation.

- Effects:

Displayed on HMI TACtouch			
Text displayed		LED ALARM	LED Pa
P.20	Initialisation of the reference pressure - Unstable supply air pressure	RED	/
P.21	Initialisation of the reference pressure - Unstable extract air pressure		
P.22	Initialisation of the reference pressure - Supply air flow too low		
P.23	Initialisation of the reference pressure - Extract air flow too low		
P.24	Initialisation of the reference pressure - Supply air flow not reached		
P.25	Initialisation of the reference pressure - Extract air flow not reached		
P.26	Initialisation of the reference pressure - Supply air flow too high - Min. limit of the motor		
P.27	Initialisation of the reference pressure - Extract air flow too high - Min. limit of the motor		

TAC5 control board				
AL1 relay	O.R.1	LED ALARM	LED AF	Fans
ALARM	/	ON	/	Stopped
Auto reset: no				

8.4 TYPE 4: ALARM INDICATING THE SYSTEM CANNOT FULFIL THE SETPOINT

- Conditions:

- Causes:

- The setpoint cannot be fulfilled because the upper or lower limit of the fan's working zone has been reached

- Effects:

Displayed on HMI TACtouch			LED ALARM	LED Pa
Text displayed				
S.11	"Constant Pressure" fan 1 - Measured pressure too high - Minimum air flow reached		RED	/
S.12	"Constant Pressure" fan 1 - Measured pressure too low - Maximum air flow reached			
S.13	"Constant Pressure" fan 3 - Measured pressure too high - Minimum air flow reached			
S.14	"Constant Pressure" fan 3 - Measured pressure too low - Maximum air flow reached			
S.20	"Demand control" fan 1 - Air flow too low - Reduce the pressure on this fan			
S.21	"Demand control" fan 1 - Air flow too high - Minimum limit of the motor reached			
S.22	"Demand control" fan 2 - Air flow too low - Reduce the pressure on this fan			
S.23	"Demand control" fan 2 - Air flow too high - Minimum limit of the motor reached			
S.24	"Demand control" fan 3 - Air flow too low - Reduce the pressure on this fan			
S.25	"Demand control" fan 3 - Air flow too high - Minimum limit of the motor reached			
S.34	"Constant Air Flow" fan 3 - Air flow too low - Reduce the pressure on this fan			
S.35	"Constant Air Flow" fan 3 - Air flow too high - Minimum limit of the motor reached			

TAC5 control board				
AL1 relay	O.R.1	LED ALARM	LED AF	Fans
/	/	ON	/	/
Auto reset: yes				

8.5 TYPE 5: ALARM INDICATING A DATA FAILURE IN THE CONTROL CIRCUIT

- Conditions:

- Causes:

- Crucial data from the circuit board has been lost

- Effects:

Displayed on HMI TACtouch			LED ALARM	LED Pa
Text displayed				
D.10	Programme Error		RED	/
D.20	Data Error			

TAC5 control board				
AL1 relay	O.R.1	LED ALARM	LED AF	Fans
Alarm status	/	ON	/	Stopped
Auto reset: no				

- Solutions:

- Try a TOTAL RESET of the data using the advanced setup. If still not resolved, order a new circuit board.

8.6 TYPE 6: FIRE ALARM

- Conditions:

- Fire alarm input must be connected to a fire detection system

- Causes:

- Activation of fire alarm input, IN3, connected to a fire detection system.
IN3 can be configured to work as NO open contact by default or as NC if configured so in the advanced setup.

- Effects:

Displayed on HMI TACtouch			
Text displayed		LED ALARM	LED Pa
F.10	FIRE ALARM	RED	/
F.11	End of the fire alarm		

TAC5 control board				
AL1 relay	O.R.1	LED ALARM	LED AF	Fans
Alarm status	/	ON	/	*

Auto reset: no

* The fans are stopped by default in the event of a fire alarm but, via the advanced setup, it is possible to configure a fixed airflow for supply (contact IN7 needs to be closed) and for exhaust (contact IN8 needs to be closed).

8.7 TYPE 7: MAINTENANCE ALARM

- Conditions:

- the running hours feature must be enabled in advanced setup

- Causes:

- SERVICE ALARM: the fan operating time (in hours) has exceeded the configurable threshold
- STOP FAN: the fan operating time (in hours) has exceeded the configurable threshold. This alarm stops the fans

- Effects:

Displayed on HMI TACtouch			
Text displayed		LED ALARM	LED Pa
M.10	Maintenance 3 months	RED	/
M.11	Maintenance 6 months		
M.21	Operating hours		
M.22	Operating hours - AHU off		

TAC5 control boards				
AL1 relay	O.R.1	LED ALARM	LED AF	Fans
Alarm status	/	ON	/	Stopped if SERVICE STOP FAN*
Reset via "fan run time" (TACtouch) or "alarm menu" (App)				

* unless the status has been changed in advanced setup

8.8 TYPE 8: ALARM INDICATING A COMMUNICATION BREAKDOWN BETWEEN THE TAC5 CIRCUIT AND THE HMI

- Conditions:

- User interface is connected

- Causes:

- Communications failure between the TAC5 circuit and the HMI

- Effects:

Displayed on HMI TACtouch		
Text displayed	LED ALARM	LED Pa
CB COM ERROR	Red	/

TAC5 control board				
AL1 relay	O.R.1	LED ALARM	LED AF	Fans
Alarm status	/	/	/	/
Auto reset: yes				

8.9 TYPE 9: ALARM INDICATING A ° SENSOR T1/T2/T3 FAILURE

- Conditions:

- Causes:

- One or more of the T° sensors T1/T2/T3 connected to the TAC5 circuit and mounted on heat exchanger is defect or not connected. These sensors are needed for the bypass control and the anti-frost procedure.

- Effects:

Displayed on HMI TACtouch			
Text displayed		LED ALARM	LED Pa
T.10	Sensor T1 disconnected	RED	/
T.11	Sensor T1 short circuit		
T.20	Sensor T2 disconnected		
T.21	Sensor T2 short circuit		
T.30	Sensor T3 disconnected		
T.31	Sensor T3 short circuit		

TAC5 control board				
AL1 relay	O.R.1	LED ALARM	LED AF	Fans
Alarm status	/	ON	/	Stopped

Manual reset mandatory.

8.10 TYPE 10: ALARM INDICATING FAILURE ON T° SENSOR T4

- Conditions:

- Only with internal water heating coil (IBA) option

- Causes:

- T° sensor T4 located on the coil and connected to the TAC5 circuit is defective (open or short circuit) or not connected. This is used to prevent frosting of the internal heating coil. In this case, as a safety measure, the 3-way valve is opened and the circulator contact is closed.

- Effects:

Displayed on HMI TACtouch			
Text displayed		LED ALARM	LED Pa
T.40	Sensor T4 disconnected	RED	/
T.41	Sensor T4 short circuit		

TAC5 control board				
AL1 relay	O.R.1	LED ALARM	LED AF	Fans
Alarm status	/	ON	/	/

Manual reset mandatory.

* unless the status has been changed in advanced setup

8.11 TYPE 10 BIS: DRAIN PUMP ALARM

- Conditions:
 - Only for GLOBAL LP
- Causes:
 - The level of condensate is higher than a set Setting (approx. 1.5 cm).
It can also be activated if the pump is not present or defective
- Effects:

Displayed on HMI TACtouch			
Text displayed		LED ALARM	LED Pa
R.10	Condensate tray full	RED	/

TAC5 control board				
AL1 relay	O.R.1	LED ALARM	LED AF	Fans
Alarm status	/	ON	/	Stopped if SERVICE STOP FAN

Auto reset: yes

When activated, the supply and exhaust fans are stopped. This alarm is automatically reset when the water level in the drain pan is lower than the setpoint, and the fans restart automatically.

8.12 TYPE 11: ALARM INDICATING FAILURE ON T° SENSOR T5

- Conditions:
 - Only with post-heating, post-cooling or free cooling with heat wheel or modulating bypass option
- Causes:
 - T° sensor T5 located in the supply duct and connected to the TAC5 circuit is open, or short-circuited. This sensor is used to regulate the post-heating or post-cooling function in the case of comfort T° control on T5 or to control the high and low thresholds to limit the supply air temperature in the case of comfort T° control on T2.
- Effects:

Displayed on HMI TACtouch			
Text displayed		LED ALARM	LED Pa
T.50	Sensor T5 disconnected	RED	/
T.51	Sensor T5 short circuit		

TAC5 control board				
AL1 relay	O.R.1	LED ALARM	LED AF	Fans
Alarm status	/	ON	/	/

Manual reset mandatory.

8.13 TYPE 12: ALARM INDICATING THAT THE COMFORT T° IS TOO LOW RELATIVE TO SETPOINT T°

- Conditions:

- Only with post-heating option

- Causes:

- The comfort T° setpoint cannot be reached (actual T° lower than setpoint during 15 minutes, or 30 minutes if comfort on T2 instead of T5, while post heating is at maximum.)

- Effects:

Displayed on HMI TACtouch			
Text displayed		LED ALARM	LED Pa
S.50	Post-heating - T° of the supply air too low	RED	/

TAC5 control board				
AL1 relay	O.R.1	LED ALARM	LED AF	Fans
/	/	ON	/	/
Auto reset: yes				

8.14 TYPE 13: ALARM INDICATING HEAT EXCHANGER FROST PROTECTION ALERT

- Conditions:

- Only with post-heating option

- Causes:

- For PX units:

Frost protection is only selected with electrical pre-heating coil (KWin) or water preheating coil (BAin) or modulating bypass. With KWin or BAin option: In certain air T° conditions as measured on the exhaust airflow after heat recovery, indicating that the internal electrical KWin coil or external hydraulic coil (BAin) has reached its limit, the TAC5 control can take over to guarantee the anti-frost function.

If T° < assignment T°-1,5°C for more than 5 minutes: supply and exhaust airflow reduction of 33% if airflow control or demand control and of 25% if pressure control mode, for 15 minutes.

- For RX units:

When outdoor temperature (T1 sensor) is lower than the anti-frost temperature (T°AF, -9°C by default), the rotation speed of the heat exchanger will decrease to avoid any risk of frosting.

When T1 ≥ T°AF for at least 5 minutes, the wheel will ramp up to its nominal rotation speed.

- Effects:

Displayed on HMI TACTouch			
Text displayed		LED ALARM	LED Pa
A.10	Anti-freeze - Reduced air flows	RED	/

TAC5 control board				
AL1 relay	O.R.1	LED ALARM	LED AF	Fans
/	/	ON	ON	/
Auto reset: yes				

8.15 TYPE 14: ALARM INDICATING FROST PROTECTION ALERT – FANS STOPPED T°

- Conditions:

- Frost protection is only selected for PX units with electrical preheating (KWin) or water preheating (BAin) or if modulating bypass

- Causes:

- With KWin or BAin option: in certain air T° conditions as measured on the exhaust airflow after the heat recovery, indicating that the internal electrical KWin coil or external hydraulic coil (BAin) has reached its limit, the TAC5 control can take over to guarantee the anti-frost function.

If T° < -5°C during 5 minutes, fans are stopped.

- With modulating bypass in frost protection (« A-FREEZE » or « AF+FREECOOL » in the advanced setup), this alarm indicates that the extracted air temperature at the exchanger output (T3 sensor) has not exceeded 1°C during 15 minutes after that the bypass has been opened at 100%.

- Effects:

Displayed on HMI TACtouch			
Text displayed		LED ALARM	LED Pa
A.11	Anti-freeze - Fans stopped	RED	/

TAC5 control board				
AL1 relay	O.R.1	LED ALARM	LED AF	Fans
Alarm status	/	ON	Blinking	Stopped
Manual reset mandatory.				

8.16 TYPE 14 BIS: ALARM INDICATING AN ERROR ON THE HEAT EXCHANGER ROTATION SPEED

- Conditions:
 - Only for RX units
- Causes:
 - This alarm indicates that the rotation speed of the wheel has been lower or greater than 15% of the setpoint speed for more than 5 minutes
- Effects:

Displayed on HMI TACtouch			
Text displayed		LED ALARM	LED Pa
B.30	Speed of rotation of the exchanger incorrect	RED	/

TAC5 control board				
AL1 relay	O.R.1	LED ALARM	LED AF	Fans
Alarm status	/	ON	/	Stopped
Manual reset mandatory.				

8.17 TYPE 15 BIS: ALARM INDICATING THAT THE COMFORT T° IS TOO HIGH RELATIVE TO SETPOINT T°

- Conditions:
 - Only with post cooling option
- Causes:
 - The comfort T° setpoint cannot be reached (actual T° lower than setpoint during 15 minutes, or 30 minutes if comfort on T2 instead of T5, while post cooling is at maximum).
- Effects:

Displayed on HMI TACtouch			
Text displayed		LED ALARM	LED Pa
S.60	Post-cooling - T° of the supply air too high	RED	/

TAC5 control board				
AL1 relay	O.R.1 relay of SAT3	LED ALARM	LED AF	Fans
/	/	ON	/	/
Auto reset: yes				

8.18 TYPE 16: ALARM INDICATING THAT THE SUPPLY T° IS TOO LOW

- Conditions:
 - Only with post heating or cooling option
- Causes:
 - This alarm indicates that the supply temperature (T5) is lower than 5°C. The fans are stopped for 1 minute. The alarm is configurable through the advanced setup and is disabled by default.
- Effects:

Displayed on HMI TACtouch			
Text displayed		LED ALARM	LED Pa
S.50	Post-heating - T° of the supply air too low	RED	/
S.60	Supply air T° too low - Fan stopped		

TAC5 control board				
AL1 relay	O.R.1	LED ALARM	LED AF	Fans
Alarm Status	/	ON	/	Stopped
Manual reset mandatory.				

8.19 TYPE 17: ALARM INDICATING HYDRAULIC COILS FROST PROTECTION ALERT

- Conditions:
 - Only with internal hydraulic post heating coil (IBA), or external heating coil (EBA)
- Causes:
 - Indicates that the anti-frost protection temperature of the hydraulic coil is lower than 4°C (configurable through advanced setup, it is important to reduce this Setting for BAin coil if an antifreeze is in the fluid). The 3-way valve is automatically opened at 100% for 15 minutes and the heating demand contact is closed (output SAT3 O.R.3). If the AHU is running, the alarm is sent after 2 minutes for a preheating coil and immediately for the others; if the AHU is not running, the alarm is sent after 5 minutes.
- Effects:

Displayed on HMI TACtouch			
Text displayed		LED ALARM	LED Pa
A.40	Anti-freeze protection of the internal post-heater (IBA)	Red	/
A.41	Anti-freeze protection of the waterborne post-heater (EBA+)		
A.42	Anti-freeze protection of the waterborne post-cooler (EBA-)		
A.43	Anti-freeze protection of the waterborne reversible coil (EBA+-)		

TAC5 control board				
AL1 relay	O.R.1	LED ALARM	LED AF	Fans
Alarm Status	/	ON	/	Stopped
Manual reset mandatory.				

8.20 TYPE 18: ALARM INDICATING AN INCORRECT POSITION OF THE MODULATING BYPASS RELATIVE TO THE ORDERED POSITION

- Conditions:
 - PX units with modulating bypass
- Causes:
 - This alarm indicates that the modulating bypass has not reached the ordered position within 10 seconds. The most common reason for this is a damaged position sensor on the bypass actuator, and this must be replaced. Other reasons may be that the control board output is damaged, implying the replacement of the board, or a mechanical blocking verified by a visual inspection of the bypass
- Effects:

Displayed on HMI TACtouch			
Text displayed		LED ALARM	LED Pa
B.20	Position of the modulating bypass incorrect	RED	/

TAC5 control board				
AL1 relay	O.R.1	LED ALARM	LED AF	Fans
Alarm Status	/	ON	/	Stopped

Manual reset mandatory.

8.21 TYPE 19: ALARM INDICATING THAT THE HOURS LIMIT FOR THE MAINTENANCE OF THE FILTERS HAS BEEN REACHED

- Conditions:
 - The basic setup parameter "Filters Resets" must be >0
- Causes:
 - Alarm indicating that the hours limit for the maintenance of the filters has been reached
- Effects:

Displayed on HMI TACtouch		
Text displayed	LED ALARM	LED Pa
FILTERS ALARM	Red	/

TAC5 control board				
AL1 relay	O.R.1	LED ALARM	LED AF	Fans
/	/	ON	/	/

Auto reset: via dedicated reset

8.22 TYPE 20: ALARM INDICATING THAT THE DEFROST PROCESS IS ACTIVE

- Conditions:
 - Unit with counter flow heat exchanger
- Causes:
 - The ice forming inside of the plate heat exchanger is generating a pressure drop that is too high for the current airflow. This detection requires a Modbus pressure sensor placed on the heat exchanger and that the modulation of the fans speed is based on the airflow and not on torque
 - When the previous detection is not available, the supply T° is checked and if it falls below 11°C, it is considered that is due to the ice that reduces the heat exchanger efficiency
- Effects:

Displayed on HMI TACtouch			
Text displayed		LED ALARM	LED Pa
A.20	Defrost	RED	/

TAC5 control board				
AL1 relay	O.R.1	LED ALARM	LED AF	Fans
/	/	ON	ON	Supply stopped
Auto reset: yes				

8.23 REC TABLE

In the control board the “REC type” is used to define the type unit. When replacing the control board, the REC type needs to be configured in the product setup menu. The product setup menu is used to enable specific features or to modify factory settings. This must be done by an accredited technician. A code and special training is mandatory to access this menu group. The table below is valid for controllers generation TAC5.

RANGE	SIZE	TAC5 DG	RANGE	SIZE	TAC5 DT	RANGE	SIZE	TAC5 DT
GLOBAL PX	800 ^{FW}	885100	GLOBAL PX	800	885270	GLOBAL RX TOP (Composite)	05	881018
	1200 ^{FW}	885101		1200	885271		08	881020
	2000 ^{FW}	885102		2000	885272		10	881022
	3000 ^{FW}	885103		3000	885273		12	881024
	4000 ^{FW}	885104		4000	885274		14	881026
	5000 ^{FW}	885105		5000	885275		16	881028
	6000 ^{FW}	885106	GLOBAL RX	6000	885276	GLOBAL RX TOP (Aluminum)	05	881054
	450 TOP ^{FW}	887103		2000	888025		08	881056
	800 TOP ^{FW}	887100		4000	888026		10	881058
	1200 TOP ^{FW}	887101		6000	888027		12	881060
2000 TOP ^{FW}	887102	9000	888028	14	881062			
RANGE	SIZE	TAC5 DT	GLOBAL LP (Composite)	02	886500	GLOBAL RX (Composite)	16	881064
GLOBAL PX (Composite)	05	885500		04	886502		05	881524
	06	885522		06	886504		08	881502
	08	885502		08	886506		10	881504
	10	885504		10	886508		12	881506
	12	885506		12	886518		13	881508
	13	885508		13	886510		14	881510
	14	885510		14	886512		16	881512
	16	885512		16	886514		18	881514
	20	885516		18	886516		20	881516
GLOBAL PX (Aluminum)	05	885524	02	/	24	881518		
	06	885546	04	/	26	881520		
	08	885526	06	886544	GLOBAL RX (Aluminum)	05	881572	
	10	885528	08	886546		08	881550	
	12	885530	10	886548		10	881552	
	13	885532	12			12	881554	
	14	885534	14	886552		13	881556	
	16	885536	16	886554		14	881558	
20	885540	18	886556	16		881560		
				18		881562		
				20	881564			
				24	881566			
				26	881568			
RANGE	SIZE	TAC5 DG	RANGE	SIZE	TAC5 DT			
GLOBAL LP	1000 ^{FW}	886102	GLOBAL LP	450 ^{FW}	886110			
	1300 ^{FW}	886268		600 ^{FW}	886112			
	1600 ^{FW}	886103						
	2000 ^{FW}	886104						

9.0 Parameters/Commissioning Sheet

Please enter all settings specific to your installation in this table. Please keep this document at hand when there is a need to contact us to report a problem.

9.1 MAIN PARAMETERS AFTER COMMISSIONING

1	GLOBAL model:		
2	Operating mode:	<input type="radio"/> Constant Airflow <input type="radio"/> Demand control	<input type="radio"/> Constant Torque <input type="radio"/> Constant pressure
3	Constant Airflow:	K1 = _____ K2 = _____ K3 = _____	<input type="radio"/> [m ³ /h] <input type="radio"/> [l/s] <input type="radio"/> [m ³ /h] <input type="radio"/> [l/s] <input type="radio"/> [m ³ /h] <input type="radio"/> [l/s]
4	Constant Torque:	K1 = _____ K2 = _____ K3 = _____	% Torque % Torque % Torque
5	Demand control:	Vmin = _____ V Vmax = _____ V m ³ h / %TQ ≡ Vmin = _____ m ³ h / %TQ ≡ Vmax = _____ % on K3 = _____	<input type="radio"/> [m ³ /h] <input type="radio"/> [l/s] <input type="radio"/> [m ³ /h] <input type="radio"/> [l/s] %
6	Constant pressure:	Assignment Pa = _____ % on K3 = _____	<input type="radio"/> [V] <input type="radio"/> [Pa] %
7	Ratio exhaust/supply:		%
8	Pressure alarm (not for pressure control mode)	Activated? <input type="radio"/> Yes <input type="radio"/> No <input type="radio"/> Automatic <input type="radio"/> Manual Setup Initialisation: Supply: _____ Exhaust: _____	<input type="radio"/> [m ³ /h] <input type="radio"/> [l/s] <input type="radio"/> [Pa] <input type="radio"/> [m ³ /h] <input type="radio"/> [l/s] <input type="radio"/> [Pa]
9	If KWin option:	T° KWin = _____	°C
10	If KWout option:	T° KWout = _____	°C
11	If IBA option:	T° IBA = _____	°C

9.2 TRACK CHANGES

Enter details when the Setting of a parameter has been changed (use only one row per parameter):

Parameter Name	Setting before change	Setting of change #1	Date of change #1	Setting of change #2	Date of change #2

Manufacturer (and where appropriate his authorized representative):

Company: P Lemmens Company S.A.
Address: Parc-industriel de Sauvenière 102 Chaussée de Tirlemont
B5030 Gembloux

Hereby declares that:

Following product range(s): GLOBAL PX (TOP) / GLOBAL RX (TOP) / GLOBAL LP /
CLASS UNIT / MURAL

Complies with the requirements of Machinery Directive 2006/42/EC (LVD included)

Complies also with applicable requirements of the following EC directives:

2014/30/EU	EMC
2009/125/EC	Ecodesign (Regulation nr 1253/2014 – LOT 6)
2011/65/EU	RoHS 2 (including amendment 2015/863/EU – RoHS 3)

Authorized to compile the technical file:

Name: Nicolas Pary
Address: Parc-industriel de Sauvenière 102 Chaussée de Tirlemont
B5030 Gembloux

Signature:

Place and date: Gembloux 2020-04-07

Signature: Name: Jean-Yves Renard
Position: R&D Director



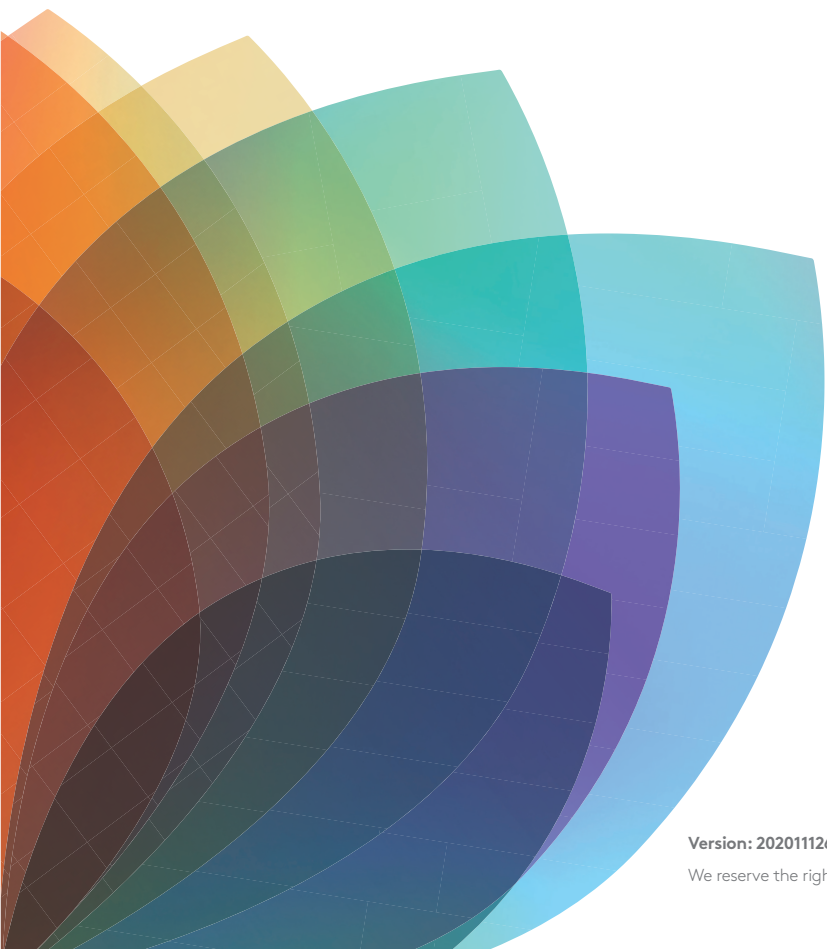

50199

Version: 202011126

We reserve the right for changes.

Swegon 