

COMPACT Unit & Top



COMPACT Unit



COMPACT Top

Contents

General.....	28
Technical Description of the Air Handling Units	30
Accessories	35
Specification	42
Sizing	44

COMPACT Unit and COMPACT Top Have That Little Extra!

Introducing the new COMPACT series, Swegon offers air handling units for small air volumes without having to reduce standards of performance, energy efficiency, control functions and communications options.

Energy-efficient Fans

The fans in the COMPACT series are direct-driven plug fans. They are equipped with EC motors that provide high efficiency across the entire operating range.

The fans are compact and take up little space. Sharp duct bends can be connected directly to the fan outlet without pressure losses. The fans also generate low noise levels.

Heat Exchanger with High Efficiency

All of the units in the COMPACT series are equipped with the RECOeconomic rotary heat exchanger, one of the most efficient heat exchangers on the market.

The temperature efficiency of the RECOeconomic is high and the pressure drop is low. The heat exchanger is driven by a step motor that permits extremely high precision for controlling the rotor speed and heat recovery efficiency as well.

Compact Filters

The air handling units are equipped with Class ePM1 50% (F7) so-called pleated filters for both the supply air and the extract air. Filter monitoring is built into the control system.



COMPACT Unit



COMPACT Top

Unparalleled Flexibility

- COMPACT Top is often the best option when space is restricted side to side and the ductwork is run from above.
- COMPACT Unit can be upended and you can choose the direction of airflow. This provides six different installation alternatives.
- Their low noise level makes it possible to install the units near utility areas and workplaces.
- Their attractive design makes it possible to place the units where they can be seen.

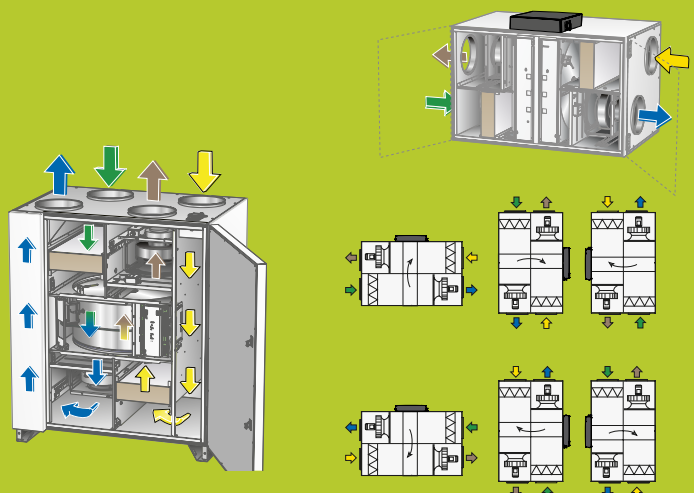

The IQnomic Control System – An Intelligent Economist on which You Can Always Rely!

Complete Control System

The IQnomic control system controls and regulates fans, heat exchanger, temperatures, airflows and in-operation periods. Every conceivable function for an air handling unit is built into the system and is ready to activate.

All the settings and readings can be entered/viewed in plain text via a user-friendly, hand-held micro terminal.

The fact that the control equipment is integrated into and specifically developed for the COMPACT ensures that its electronics and mechanics operate hand in hand.

Smart and Economical Control Functions

Typical smart and economical control functions available only in the IQnomic from Swegon:

- **ERS Regulation (control).** Can be used when the rooms served have surplus heat. In most cases, no reheating coil is needed.
- **Density-corrected airflow.** Automatically takes into consideration how the air density varies and accordingly provides different air volume at different temperatures.
- **Seasonally compensated airflow.** The airflow can be reduced in the winter according to a preset performance curve.
- **Summer night cooling.** An energy-saving function for supplying cool outdoor air to the rooms at night.
- **Cooling BOOST and Heating BOOST.** The airflow can be adjusted according to the cooling and heating loads respectively.
- **Cooling recovery.** The heat exchanger is also automatically utilised for recovering the relative cooling energy that can be present inside the room.



Hand-held Micro Terminal



IQnomic

COMPACT Unit & Top

Communication Is Standard

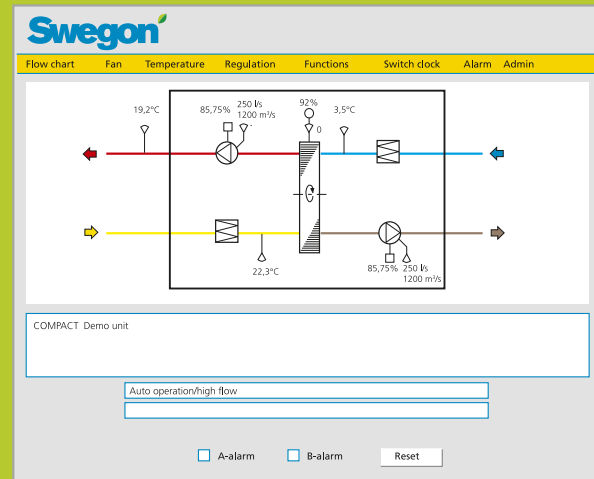

Technical Description of the COMPACT Unit & Top Units

General

The COMPACT Unit and COMPACT Top units are complete air handling units with direct-driven supply air and extract air fans, supply air and extract air filters, rotary heat exchanger and built-in control equipment.

The two sizes have the same physical dimensions but different airflow capacity.

The COMPACT Unit has duct connections arranged on its side panels. The COMPACT Top has all its duct connections arranged at the top of the unit.

The air handling unit is equipped with a pressure adjusting plate used for achieving a correct direction of air leakage across the heat exchanger. This prevents extract air from being carried over to the supply air.

Built-in Control Equipment

The COMPACT Unit and COMPACT Top have built-in control equipment that can be operated from the hand-held micro terminal with a clear-text display.

The electrical and control system is completely integrated into the air handling unit. The microprocessor-based equipment controls and regulates temperatures, airflows and other functions. A large number of functions are built into the system and are simple to activate.

Range of Application

The COMPACT Unit and COMPACT Top units are designed for comfort ventilation and can be used in offices, schools, day nurseries, public premises, shops and residential buildings.

The COMPACT unit should be installed indoors.

Swegon recommends that the floor in the ventilation room be supplied with a sealing layer in cases where there is a risk of condensation in the air handling unit. For example, condensation can form in air handling units with air coolers.

The COMPACT is designed and tested for ambient temperatures from -25°C to +40°C, and temperatures in the air stream from -40°C to +40°C. However, for the rotary heat exchanger the temperature difference between the outdoor air and extract air must not exceed 70°C.

The COMPACT Unit and COMPACT Top units generate low noise levels. This makes it possible to install the units near utility areas and workplaces.

The air handling units have an attractive and modest design making them ideal for installation where they can be seen in the premises.

Simple Installation

A standard installation is simple. Besides fitting the duct system and air diffusers, the fitter only needs to connect the unit to a power supply and install a temperature sensor inside the supply air duct.

Ready-to-use connection terminals and control functions are provided for accessories such as dampers, air heaters and air coolers.

Certification

Swegon AB has a certified Quality Assurance System that conforms to ISO 9001 Standard and a certified Environmental Management System to ISO 14001.

The COMPACT Unit & Top air handling system is also certified by Eurovent, No. AHU-09-05-426.



COMPACT Unit



COMPACT Top



www.eurovent-certification.com

Technical Description of the COMPACT Unit & Top Units

Mechanical Design

Casing

The room unit casing has an outer skin of galvanized sheet steel that has been prepainted in a shade of white (NCS S 0502-G), and has an inner skin of aluminium-zinc plated sheet steel and Magnelis. The rear side of the COMPACT Top consists of aluminium-zinc plated sheet steel.

The exterior surfaces of the room unit conform to Environmental Class C4. The casing has 30 mm thick mineral wool insulation; the inspection door has 50 mm thick insulation.

The inspection door(s) is/are hung on hinges. The door(s) is/are opened and closed using a special key. A lockable door lock is available as an accessory.

Fans

The fans are direct-driven plug fans. They are equipped with EC motors that provide high efficiency across the entire operating range. Flow measurement and control are standard.

The fans are effectively vibration-isolated from the casing. They can be dismantled and removed from the air handling unit if required.

Heat exchanger

The rotary heat exchanger is of REConomic type. The heat exchanger is driven by a step motor that controls the rotor speed with high precision and controls the heat recovery efficiency as well.

The rotary heat exchanger is available in three versions, MPE (Maximum Pressure Efficiency), STE (Standard Temperature efficiency) and MTE (Maximum Temperature Efficiency). In the MPE version, the focus is on low pressure drop across the heat exchanger and in the MTE version the maximum temperature efficiency is prioritised. In the STE version, the heat exchanger is a balance between pressure drop and temperature efficiency, which means a lower pressure drop than in the MTE version and a higher temperature efficiency than in the MPE version.

The rotation monitor and controls are standard equipment.

It is available in a sorption version for moisture recovery, which reduces operating and investment costs for cooling and improves indoor comfort levels in the winter.

Filters

The air handling unit has pleated Class ePM1 50% (F7) filters for both the supply air and the extract air. Filter monitoring is built into the control system.

Environmental Product Declaration

Swegon AB has a certified environmental management system that conforms to ISO 14001 Standard and is registered on the REPA Register, no. 5560778465.

The COMPACT units are made of the following materials:

Type of Material	Percentage of total weight
Sheet steel	Approx. 80%
Aluminium	Approx. 8%
Polymeric material	Approx. 1%
Mineral wool insulation	Approx. 2%
Filter	Approx. 1%
Electronic equipment, motors	Approx. 8%



Direct-driven fans with EC motors.

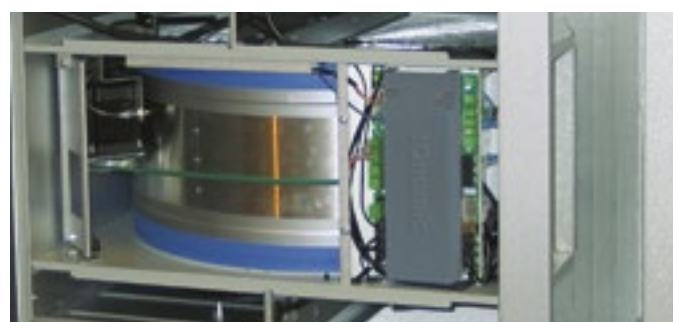

REConomic rotary heat exchanger.

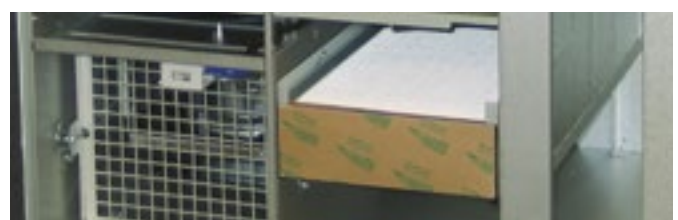

Pleated Class ePM1 50% (F7) filter.

COMPACT Unit & Top

Technical Description of the COMPACT Unit & Top Units

Electrical and Control System

General

The IQnomic control system is completely integrated into the air handling unit. The microprocessor-based equipment controls and regulates temperatures, airflows and other functions. A large number of functions are built into the system and are simple to activate. See the special section entitled "Description of the Control System".

The air handling unit can be automatically controlled in several ways via the integrated time switch, however it can also be demand-controlled via a CO₂ sensor or presence detector. Manual control is also possible.

A large number of functions and settings can be also activated/entered via communication.

Control Inaccuracy:

Temperature ± 1°C.
Airflow ± 5%.

Power Efficiency

The design and performance of the air handling unit are optimized for achieving excellent power efficiency.

Standards

The air handling unit conforms to the provisions in the SS-EN 60204-1 Standard.

Interference Level

The air handling units conform to the provisions of the EMC Directive and are tested according to EN 61000-6-2 and EN 61000-6-3 Standards. (radiation in residential buildings, office buildings, shops and similar indoor environments and for immunity in industrial facilities).

Use of an earth fault circuit breaker

The earth fault circuit breaker, if required, should only serve the air handling unit and must be of a type designed for use with the control system of the EC motor.

Communication

Communication via TCP/IP and EIA 485 is included as standard. The TBLZ Communication unit is used for communication via LON and Trend.

The COMPACT also has built-in web communication. Communication with the COMPACT can be established via an ordinary web browser (such as Internet Explorer) and your own network, i.e. without any main control systems whatever.

In addition to the above, the COMPACT units have inputs and outputs for external functions such as the forwarding of alarms or overtime operation that can be keyed in.



IQnomic control unit

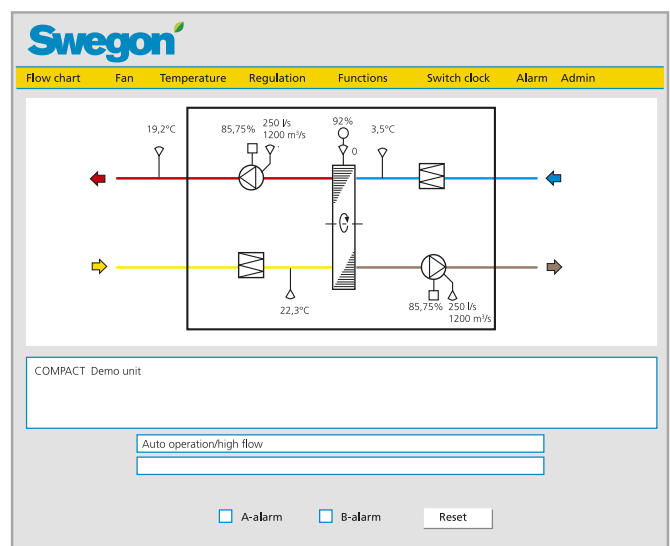

Typical flow diagram for web communication.

Technical Description of the COMPACT Unit & Top Units

Electrical and Control System

Flow Diagrams

When you calculate performance data in the ProUnit AHU selection program, the program furnishes a project-specific flow diagram and a description of the unit's functions.

The individual components are specified below.

COMPACT Unit

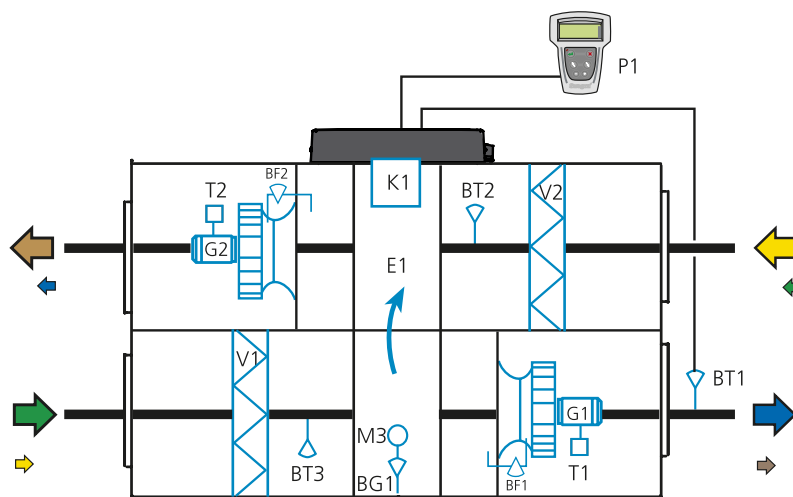

COMPACT Top

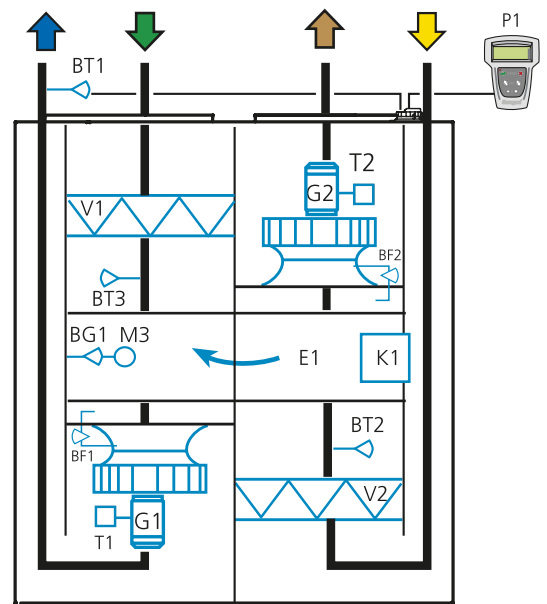

Making a simple adjustment in the control equipment enables you to change the directions of airflow through the COMPACT Unit at the building site (small arrows). The relevant components automatically change function as well.

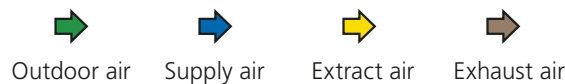

Components

V1	Outdoor air filter.	BT1	Supply air temperature sensor. To be positioned in the ductwork. Indicates for control of functions that affect temperature.
BT3	Outdoor air temperature sensor. Indicates for control of functions that affect temperature.	V2	Extract air filter.
E1	Variable speed-controlled REConomic rotary heat exchanger with air purging operation.	BT2	Extract air temperature sensor. Indicates for control of functions that affect temperature.
M3	Step motor for variable speed control of the rotary heat exchanger.	G2	Direct-driven extract air fan with EC motor.
BG1	Rotation monitor sensor for monitoring the heat exchanger's rotation.	T2	Motor control system for variable regulation of the extract air fan
G1	Direct-driven supply air fan with EC motor.	BF2	Extract air flow pressure sensor. Indicates for control of the extract air fan's speed and monitors the filter status.
T1	Motor control system for variable regulation of the supply air fan	K1	IQnomic control unit containing control circuit card and other electrical equipment for controlling internal and external functions.
BF1	Flow pressure sensor, supply air. Indicates for control of the supply air fan's speed and monitors the filter status.	P1	Hand-held micro terminal for setting and reading airflows, temperatures, control functions, in-operation periods, etc. as well as alarms.

COMPACT Unit & Top

Technical Description of the COMPACT Unit & Top Units

Electrical and Control System

Hand-held micro terminal

All the settings and readings can be entered/viewed in plain text via a user-friendly, hand-held micro terminal.

The hand-held micro terminal has keys for entering the various commands. The display screen and the keys have background lighting. A red indicating LED flashes in the event of an alarm. The preset values are stored and will not be affected in the event of a power failure.

The control panel contains logically composed menus arranged in various levels as follows:

- Main menu. Intended for reading the operating status and for entering temporary changes in how the unit operates.
- User level. Intended for entering settings and viewing readings for the functions selected.
- Installation level. An access code is required (obtainable in the maintenance instructions). Selection of functions and the setting of limit values.
- Service level. An access code is required (disclosed on completion of special training course).



Hand-held micro terminal

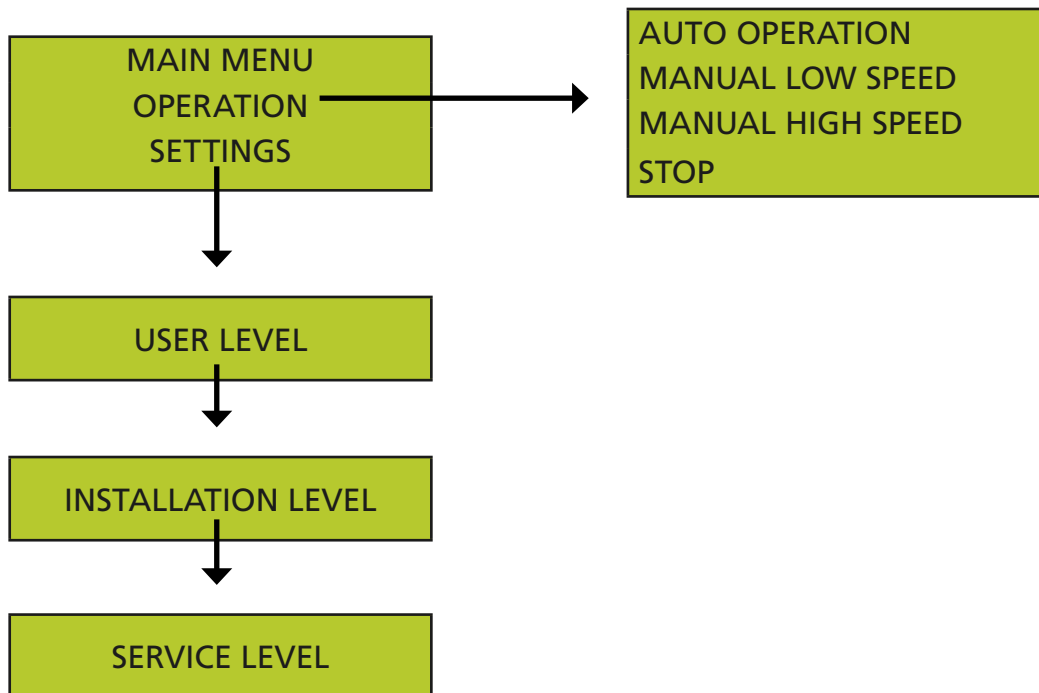

Principle structure of the menu system.

Accessories, COMPACT Unit & Top

Duct Accessories

General

The duct accessories must be positioned in the ductwork outside the COMPACT unit. The unit's fans make it possible to connect duct accessories directly to the unit's duct connections without pressure losses or non-uniform air distribution.

The duct accessories for the COMPACT are fitted with rubber seal rings.

Other particulars for sizing can be obtained by using the ProUnit air handling unit selection program.

TBSA Damper

Designed for preventing cold draughts while the air handling unit is switched off. The IQnomic controls the operation of the damper.

Technical Data

Complete with damper actuator for 230 V. The actuator can be selected with spring return or on/off actuation. Tightness Class 3 to EN 1751 Standard.

Installation

Can be mounted in a horizontal or vertical duct. Connect the controls and power supply to the air handling unit's control unit.

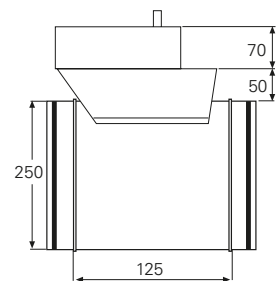

Weight: 5 kg

COMPACT Unit & Top

TBDA Unit silencer

The TBDA unit silencer is a circular sound absorber designed for installation in a duct.

Technical Data

Made of galvanized sheet steel.

The sound attenuating material consists of 100 mm thick mineral wool. This is covered with Fartex®, a patent-pending self-supporting surface layer, that has been approved in terms of ease of cleaning, minimal fibre entrainment by the airflow, resistance to ageing and minimal emissions.

The connection spigots are fitted with rubber seal rings.

Fire-resistance Class

The TBDA has been granted type approval (TG 0783) for Fire-resistance Classes EI30/EI20, EI60/EI20 respectively. EI120/EI20 on condition that it is installed at a safe distance of 50 mm from a combustible structural element.

In buildings in which the safe distance from a combustible material and/or persons in an evacuation route is not complied with, the TBDA then has Fire-resistance Class EI60/EI20.

Installation

Provision for inspection and cleaning must be guaranteed.

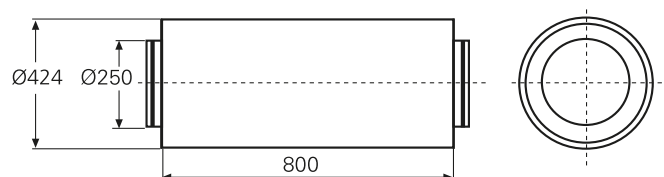
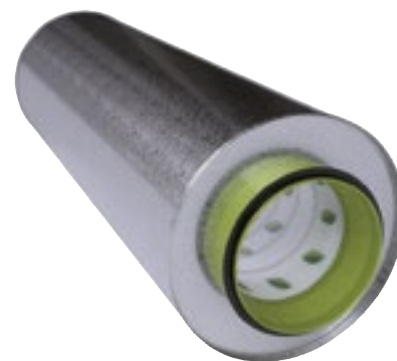

Weight: 15 kg

Accessories, COMPACT Unit & Top

Duct accessories

TBLA Air heater, for hot water

The TBLA air heater is used, if required, for reheating the supply air with hot water as the heating medium.

Technical Data

Uninsulated casing made of galvanized sheet steel.

Finned-tube heat exchangers fabricated of copper tubes and profiled aluminium fins. The headers and the pipework to the water connections are made of copper. The pipe connections are made of brass and have male threads.

Accessories

Valve set/Set of electrical connection components

Valve set with 2(3)-way valve, actuator, anti-frost protection sensor and connection cable with quick-fit connector can be ordered. If you install a valve of your own, you can instead select a set of electrical connection components. This set contains a connection cable with quick-fit connector, resistor and insertion or strap-on sensor.

Circulation pump

Circulation pump used for protecting the anti-frost protection monitor function for the air heater. Supplied with T coupling, non-return valve and adjustment valve. The automatic pump control system is integrated into the COMPACT control equipment.

Installation

The TBLA air heater can be installed for horizontal or vertical airflow. Provision for inspection and cleaning must be guaranteed.

The installation of accessories (if required), fitting of pipe connections and filling the circuit with liquid must be done at the building site.

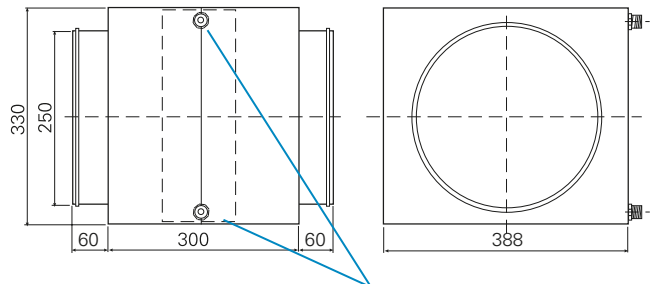

Pipe connection, male threads, DN 15

Weight: 7 kg excluding liquid

Basic Installation Diagram

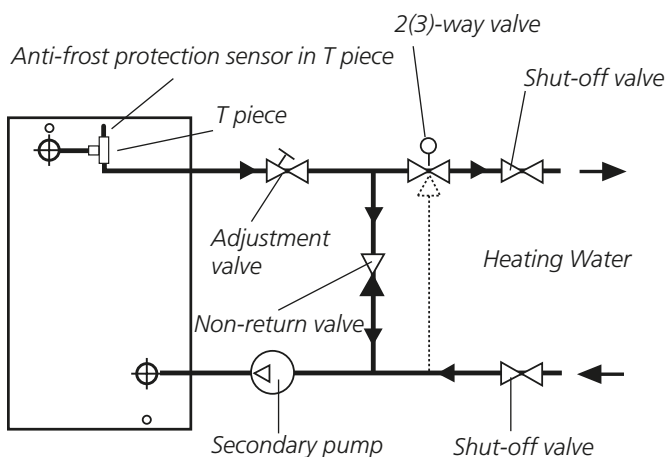

Accessories, COMPACT Unit & Top

Duct accessories

TBCE Electric air heater

The TBCE electric air heater is used reheating the supply air.

Technical Data

Uninsulated casing made of galvanized sheet steel and heating elements made of stainless material.

The TBCE air heater is available in two capacity variants.

The integrated thyristor is controlled via signals from the COMPACT air handling unit. The TBCE has four series-coupled over-heat protection devices. The electrical equipment conforms to the provisions of Degree of Protection IP44.

The air heater is approved for operating temperatures, in the surroundings and the air stream, from -25°C to +40°C.

Installation

The TBCE air heater can be installed for horizontal or vertical airflow.

Provision for inspection and cleaning must be guaranteed.

The end panel on the connection side can be dismantled for inspection and wiring electrical connections.

The distance from or to a duct bend, damper, filter or the like should be at least the distance that is equivalent to double (triple recommended) the diameter of the duct. Otherwise there is risk that the airflow through the electric air heater will be non-uniform, involving risk that the overheat protection device will trip.

Power must be supplied directly from the electrical distribution box. An isolating switch is recommended. Connect the control signal cable with quick-fit connector to the air handling unit's control unit.

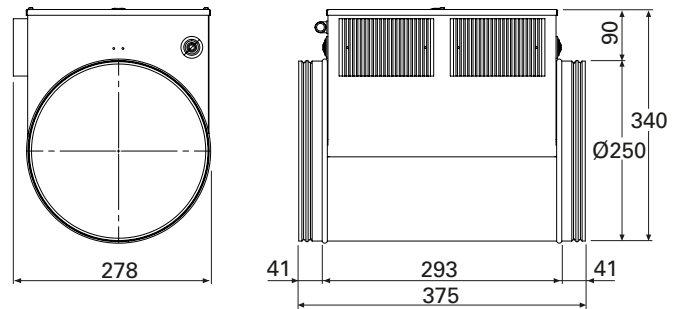

Weight: 6 kg

Accessories, COMPACT Unit & Top

Duct accessories

TBKA Air Cooler, for chilled water

TBKC Air cooler, direct expansion

The TBKA/TBKC air coolers are used for cooling the supply air with chilled water or evaporative refrigerant as the cooling medium.

The TBKA/TBKC air coolers are available in several capacity variants that cover existing needs for the COMPACT.

Technical Data

Uninsulated casing made of galvanized sheet steel.

The TBKA/TBKC air coolers consist of copper tubes and profiled aluminium fins. The TBKA has water connections made of copper/brass, with male connection threads. The TBKC has water connections made of copper designed for soldered joints.



Accessories

Controls

An IQnomic plus module is required for controlling water-based cooling. The IQnomic Plus is an extra module for the air handling unit's control system.

The regular outputs of the air handling unit are used for cooling with direct expansion in one step. If this is not sufficient then the IQnomic Plus should be used.

Valve set

The TBVA Valve set consisting of a 2(3)-way valve including actuator can be ordered.

Installation

The TBKA/TBKC air cooler must be installed for horizontal air flow. Duct connections have a 315 mm diameter, thus a 250-315 mm duct transition piece is required (not included in the supply).

Provision for inspection and cleaning must be guaranteed.

The installation of accessories (if required), fitting of pipe connections and filling the circuit with liquid must be done at the building site.

TBKA, chilled water

Water pipe connections, male threads, capacity variant 1: DN 15, capacity variant 2: DN 20.

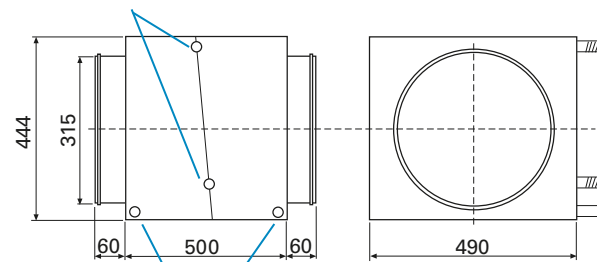

Pipe connection, drainage, male threads, DN 15.

Weight: Capacity variant 1, 21 kg, capacity variant 2, 24 kg, not including liquid

TBKC (direct expansion)

D1: Refrigerant pipe connections, smooth pipe end D1, male threads, 12 mm.

D2: Refrigerant pipe connections, smooth pipe end D2, male threads, 12 mm.

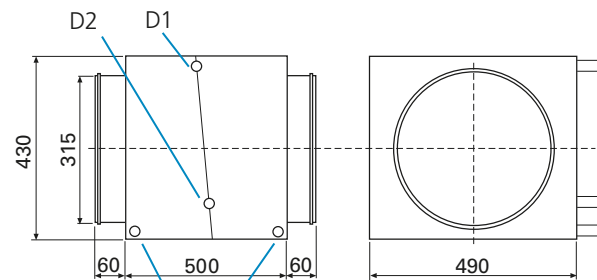

Pipe connection, drainage, male threads, DN 15

Weight: 37 kg excluding liquid

Accessories, COMPACT Unit & Top

Roof Hoods

General

The roof ducts are made of galvanized sheet steel. Lined inside with 50 mm thick insulation to Fire-resistance Class EI30, with a surface covering of type-approved synthetic woven fabric. Two angle brackets for connection to the relevant roof slope are included.

The hoods are made of aluminium-zinc plated sheet steel covered with a Plastisol (black) surface coating that conforms to Environmental Class C4.

The hoods have round duct connection, fitted with rubber seal rings for spiral ducts. Duct connections have a 315 mm diameter, thus a 250-315 mm duct transition piece is required (not included in the supply).

TBHA Outdoor air hood

Designed for the intake of outdoor air. The design of the hood makes it difficult for snow and rain drops to enter the hood with the incoming air. The hood is hinged and has air intake louvres on both sides.

TBHB Exhaust air hood

Designed for the discharge of exhaust air. The hood can be opened on hinges and is equipped with air deflectors that effectively direct the exhaust air upward and give the air high discharge velocity. To achieve low pressure drop, the air deflectors are rounded off on both their long sides. The hoods are equipped with effective provision for drainage.

TBHC Dual-purpose hood

The TBHC is a combination of TBHA outdoor air hood and TBHB exhaust air hood

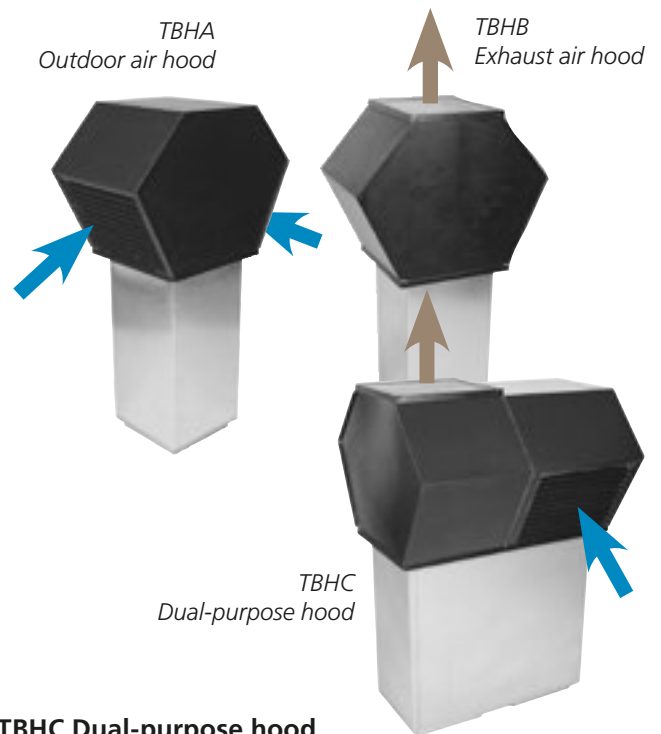

TBHA Outdoor air hood and TBHB Exhaust air hood

TBHC Dual-purpose hood

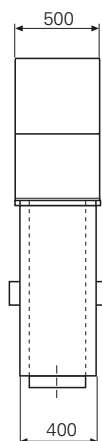
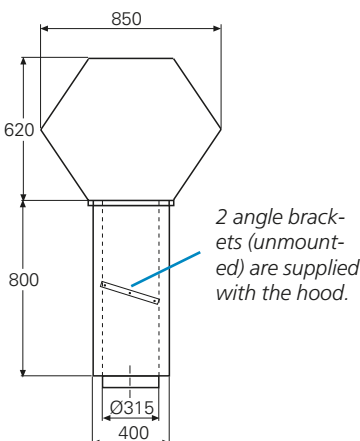

Weight: 31 kg

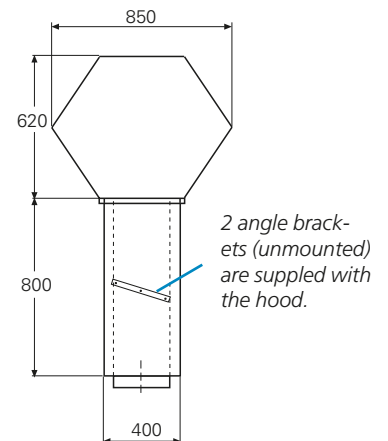
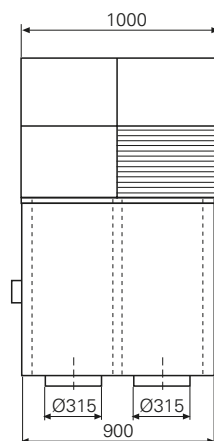

Weight: 70 kg

COMPACT Unit & Top

Accessories, COMPACT Unit & Top

TBHF External wall hood

For the admission of outdoor air and the discharge of exhaust air.

The exhaust air is horizontally discharged through a circular wire mesh grille at the front of the hood. Outdoor air is admitted through a wire mesh grille at the bottom of the hood. This design effectively prevents short-circuit airflow between the outdoor air/exhaust air.

Made of aluminium-zinc plated sheet steel painted dark grey, RAL 7021 (equivalent to NCSS 8502-B), Environmental Class C4. Available in two variants, with or without acoustic insulation.

Installation

The 250 mm dia. connections are fitted with rubber seal rings. When you cut an opening in a wall, bear in mind that the ducts must be insulated with at least 30 mm thick insulation and with damp-proof outer layer material.

The front panel of the external wall hood can be lifted off (after removing its screws), reversed and resecured. This makes the duct connections for exhaust air and outdoor air optional.

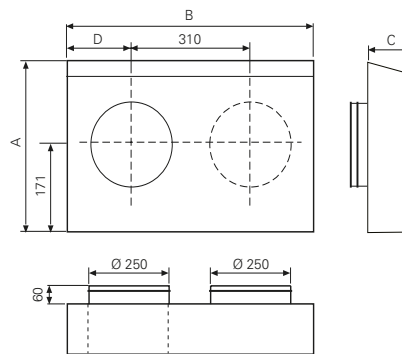
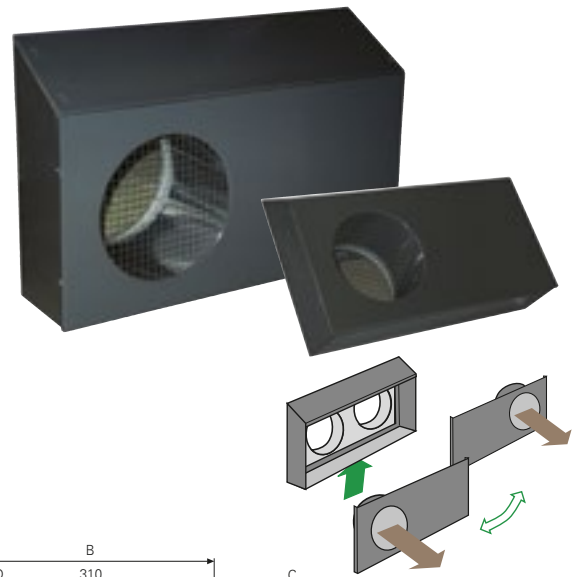

TBHF	A	B	C	D
Without acoust. insul.	440	683	167	185
With acoust. insul.	470	830	220	260

Mechanical equipment

TBLZ Stand

Specially designed stand for the COMPACT Unit. The height of the stand makes it possible to install ducts under the air handling unit.

The stand is made of galvanized sheet steel profiled sections. The stand is supplied in assembly kit form. Can be installed with or without legs. Height without feet: 100 mm.

The long sides (A in the illustration) are used for horizontal installation and the shorter sides (B) are used for vertical installation.

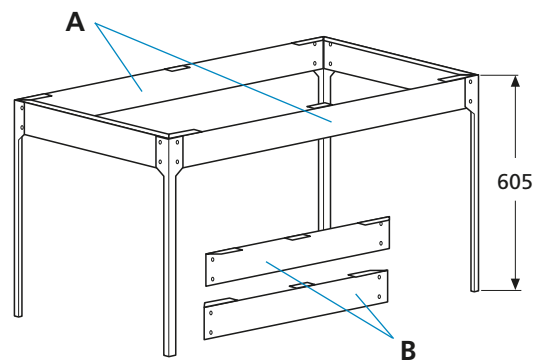

Stand. Two pairs of long sides are supplied. A is used for horizontal installation and B is used for vertical installation.

TBLZ Cover holder

The cover holder is a practical accessory for the upper inspection door for COMPACT Unit installed vertically. The cover holder consists of a mechanical stay with latch and is supplied in unmounted condition.

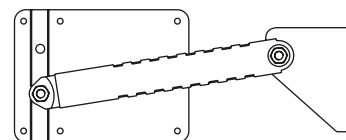

TBLZ Door Lock

For use where more stringent demands on security are made as opposed to locking with a standard special key. Supplied in sets of 2 locks with key for replacement of the existing lock at the building site.

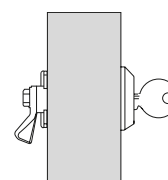

Accessories, COMPACT Unit & Top

Electrical and control equipment

Presence detector

For controlling high and low speed operation instead of the unit's built-in timer. As soon as the sensor registers the presence of an occupant in the room, the air handling unit is controlled to the high speed mode; when there are no occupants, to the low speed mode.

To be connected via appropriate terminals on the control unit.

Pressure sensor

For use in conjunction with the VAV pressure control function, when constant pressure must be kept in the ductwork. Also for use in conjunction with the heat exchanger defrosting function, when the pressure across the heat exchanger must be controlled. The connection cable is included. A 1–15 m long cable can be selected.

To be connected via appropriate terminals on the control unit.

Air quality sensor

For controlling high and low speed operation instead of the unit's built-in time switch. The air quality sensor registers the carbon dioxide content in the room air and the control unit regulates the airflow required within preset limits.

Available installation in a duct or in a room. To be connected to appropriate terminals on the control unit.

VOC sensor

For variable control of the airflow. The VOC sensor senses the content of emissions/impurities in the room and the airflow is regulated within preset limits.

To be mounted inside the air handling unit. To be connected to appropriate terminals on the control unit.

Room sensor

For use when the unit's built-in extract air temperature sensor does not provide representative values.

Designed for wall-mounting and is available for Enclosure Class IP 20. To be connected to appropriate terminals on the control unit.

Timer, Mechanical

For time-limited overtime operation when the unit's built-in time switch has controlled the unit to operate in the low speed mode or to stop.. For strap-on mounting.

To be connected to appropriate terminals on the control unit.

Timer, electronic

For time-limited overtime operation when the unit's built-in time switch has controlled the unit to operate in the low speed mode or to stop. For strap-on mounting.

To be connected to appropriate terminals on the control unit. Separate power supply

Pushbutton

For overtime operation when the unit's built-in time switch has controlled the unit to operate in the low speed mode or to stop. For strap-on mounting. Can be selected with or without indication.

To be connected to appropriate terminals on the control unit.

Connection Cable

0.25-15 m for hand-held micro terminal, pressure transducer and IQnomic Plus.

Extension Cable

5-8 m long for air heater for hot water, electric air heater and supply air temperature sensor, 8 m long for hand-held micro terminal.

Extension kit for hand-held micro terminal

For lengthening the cable, 6-50 m

Extra hand-held micro terminal

Including holder and 3 m long cable

Strap-on sensor

Temperature sensor for mounting against the surface where readings are to be taken.

SD card

For program transmissions and logging

IQnomic Plus

The extra functions for which the inputs and outputs are not included as standard in the unit's control unit, for example external monitoring and cooling.

TBLZ Communication unit

For communication via LON FTT-10 – Lon Works and Trend (communication via TCP/IP and EIA 485 as well as via internal webserver is standard in the COMPACT).

To be connected to the communication port of the control unit. Power can be supplied from appropriate terminals on the control unit.

Fire and smoke protection

The fire and smoke protection function consists of three separate units:

- TBLZ Equipment cubicle
- TBLZ Smoke detector
- ELQZ* Damper actuator.

The cubicle contains the control unit and connections. The smoke detector stops the air handling unit and controls the damper actuators to close the dampers. An alarm is presented in the hand-held micro terminal of the COMPACT air handling unit.

*) Applicable to installations in Sweden: The ELQZ damper actuator can be used where type-approved solutions are not required. If a type-approved solution is required, the damper and actuator must be supplied as a unit in a type-approved version. In these cases, a pump-exercising mode is also required.

Specification, COMPACT Unit & Top

Air handling unit

Air handling unit, COMPACT Unit			CU-aa-B-c-d
Size	02	= 02	
	03	= 03	
Heat exchanger	standard	= 1	
	sorption	= 3	
	STE	= 1	
	MTE	= 2	
	MPE	= 3	

Air handling unit, COMPACT Top			CT-aa-B-c-d
Size	02	= 02	
	03	= 03	
Heat exchanger	standard	= 1	
	sorption	= 3	
	STE	= 1	
	MTE	= 2	
	MPE	= 3	

Replacement Material

Set of filters, pleated filter, COMPACT **TBFZ-1-07**
For supply air and extract air

Hoods

Outdoor air hood **TBHA-1-031**
Including roof duct, 315 mm dia. duct connection

Extract air hood **TBHB-1-031**
Including roof duct, 315 mm dia. duct connection

Dual-purpose hood **TBHC-1-031**
Including roof duct, 315 mm dia. duct connection

External wall hood **TBHF-2-0025-b**
Combination hood for outdoor air/exhaust air

Insulation	Without	= 0	
	With	= 1	

Mechanical equipment

Stand **TBLZ-1-03-05**
Assembly kit (for COMPACT Unit only)

Cover holder **TBLZ-1-10-07**
For the upper door for vertical installation (for COMPACT Unit only)

Door lock **TBLZ-1-57**
Set of two door locks with key.

Duct accessories

Damper with motor **TBSA-1-000-025-1-a**
Tightness Class 3, 250 mm dia. duct connection, uninsulated damper blades
Damper motor:
With spring return = 1
On/off = 2

Air handling unitsilencer **TBDA-1-000-025-080**
Duct connection size, 250 mm dia., 800 mm long

Air heater for hot water: **TBLA-4-000-025-2-1**
Duct connection size, 250 mm dia.

Valve set, cooling and heating **TBVL-3-aaa-b**
2(3)-way valve including actuator, cable and insertion-type sensor
Valve size:
Kvs 0.25 = 002
Kvs 0.40 = 004
Kvs 0.63 = 006
Without sensor = 0
Insertion-type sensor = 1
Strap-on sensor = 2

Set of electrical connections: **TBLZ-1-27-a**
For air heater for hot water
Cable, resistor and insertion sensor = 1
Cable, resistor and strap on sensor = 2

Circulation pump **TBPA-5-aaa**
Set of pump components for the secondary side for air heater without anti-frost protection, including non-return valve and adjustment valve.
Capacity at max 25 kPa pressure drop in air heater and pipework:
< 0.09 l/s = 009
0.091-0.17 l/s = 017

Electric air heater **TBCE-1-000-025-002-2**

Air cooler, for chilled water **TBKA-5-000-031-1**
Capacity variant 1. 315 mm dia. duct connection

Air cooler, for chilled water **TBKA-5-000-031-2**
Capacity variant 2. 315 mm dia. duct connection

Valve set, cooling and heating **TBVA-1-aaa**
2(3)-way valve including actuator.
Valve size:
Kvs 0.25 = 002
Kvs 0.40 = 004
Kvs 0.63 = 006
Kvs 1.0 = 010
Kvs 1.6 = 016
Kvs 2.5 = 025
Kvs 4 = 040
Kvs 6.3 = 063

Air cooler, direct expansion **TBKC-4-000-031-1-1**
Duct connection size, 315 mm dia. 1 section.

Specification, COMPACT Unit & Top

Electrical and Control Equipment

Presence detector TBLZ-1-56

Pressure sensor
Contains pressure sensor and connection cable.

TBLZ-1-23-aa

Version:

Sensor only	= 00
1 m	= 01
3 m	= 03
5 m	= 05
10 m	= 10
15 m	= 15

Air quality sensor, room ELQZ-2-504

VOC sensor TBLZ-1-60-1-1

Room sensor TBLZ-1-24-2

For wall mounting. Enclosure Class IP 20.

Timer, mechanical ELQZ-1-406-1

For strap-on mounting.
0-2 hour prolonged operation

Timer, electronic TBLZ-2-47

Pushbutton for prolonged operation TBLZ-1-81-a

Without indicating LED	= 0
With indicating LED	= 1

Connection cable TBLZ-1-26-aa

For hand-held micro terminal, pressure sensor, TBIQ

Version:

1 m	= 01
3 m	= 03
5 m	= 05
10 m	= 10
15 m	= 15

Connection cable TBLZ-2-26-aa

For hand-held micro terminal, pressure sensor, TBIQ

Version: 0.45 m	= 00
--------------------	------

Extension cable TBLZ-1-05-a

With quick-fit connector

Version:

5 m long for air heater, electric or water coil	= 1
5 m long for supply air sensor	= 2
8 m long for terminal, pressure sensor, TBIQ	= 3

Extension kit for hand-held micro terminal TBLZ-2-13

For extending the cable 6 – 50 m

Strap-on sensor TBLZ-1-32

SD card TBLZ-1-62-a

Flash card for program transmissions and logging

Version:

Without COMPACT program	= 1
With COMPACT program	= 3

IQnomic Plus TBIQ-2-1-aa

Functional module and connection cable

Version:

0.25 m	= 00
1 m	= 01
3 m	= 03
5 m	= 05
10 m	= 10
15 m	= 15

Modular/terminal adaptor TBLZ-1-55

Communication unit TBLZ-3-1-a-41

For interface:

LON FFT-10	= 1
Tend	= 2

Fire and smoke protection

Equipment cabinet for fire and smoke protection function TBLZ-2-48-1

Including control unit for smoke detector

Smoke detector, optical TBLZ-2-49-1

Venturi tube, 600 mm

Mounting fittings for smoke detector, for circular or insulated ducts TBLZ-1-53

Damper actuator ELQZ-1-428-3-a

With spring return	= 1
With spring return and limit switch	= 2

Sizing

COMPACT Unit, size 02

STE

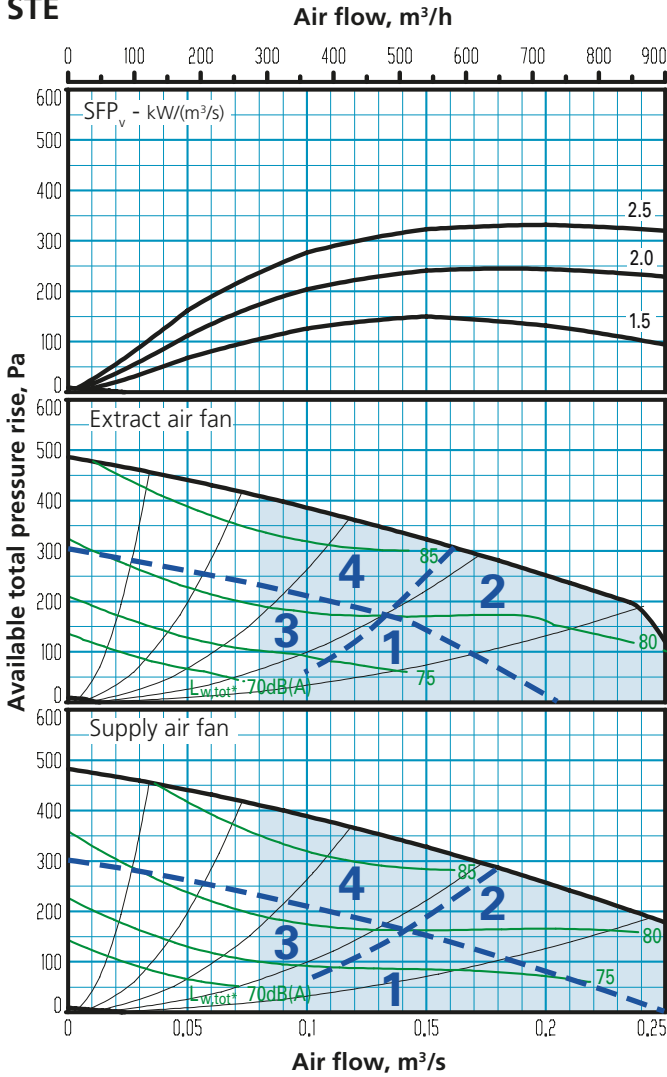

The air handling units comply with requirements to Ecodesign 2018.

COMPACT Unit, size 03

STE

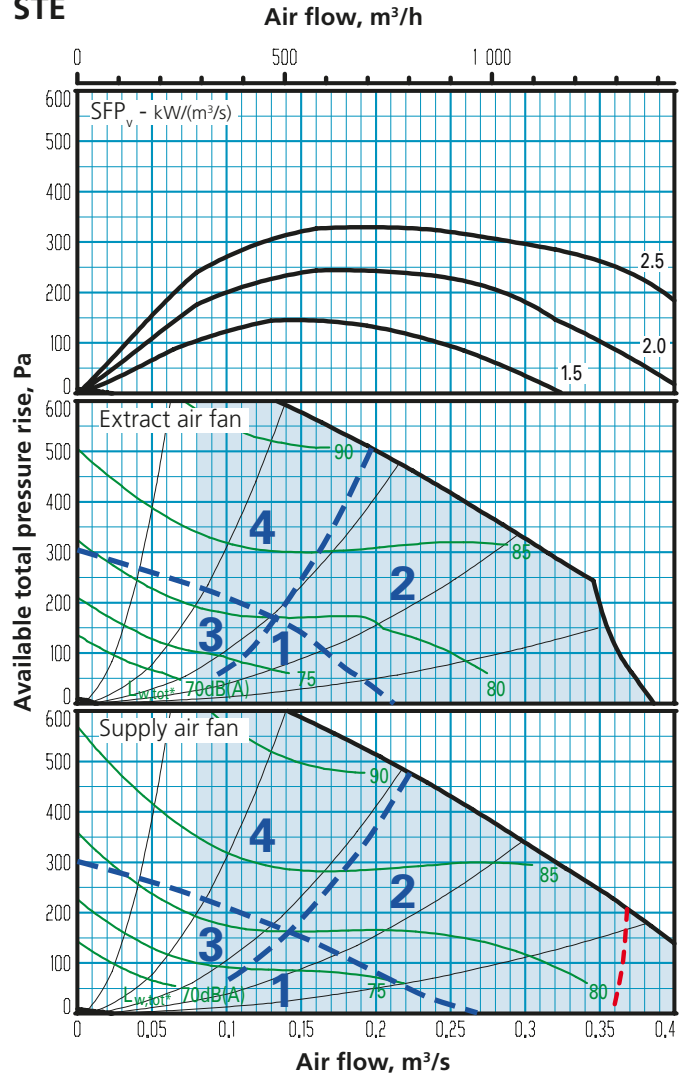

For Ecodesign, the mean value for supply air and extract air must be within the limit line.

--- Limit line, Ecodesign, 2018

COMPACT Unit Correction factors, K_{OK} , dB

Sound path	Range in the diagram	Octave band, no./mid-frequency, Hz							
		1	2	3	4	5	6	7	8
		63	125	250	500	1000	2000	4000	8000
To the outlet duct	1	-1	-1	-10	-15	-16	-17	-23	-26
	2	1	-5	-3	-12	-14	-15	-20	-19
	3	0	-1	-10	-21	-21	-23	-30	-36
	4	-2	-4	-3	-17	-18	-19	-24	-28
To the inlet duct*	1	-4	7	-9	-21	-21	-22	-24	-34
	2	-5	-5	0	-19	-18	-21	-23	-28
	3	1	2	-12	-24	-25	-28	-31	-42
	4	-2	-2	-2	-20	-22	-25	-25	-35
To air handling unit's surroundings**	1	-12	-15	-30	-36	-42	-50	-54	-57
	2	-10	-19	-23	-33	-40	-48	-51	-50
	3	-11	-15	-30	-42	-47	-56	-61	-67
	4	-13	-18	-23	-38	-44	-52	-55	-59

Min. and max. air flows, COMPACT Unit

The tabulated flows are those that are possible to set. The practical flow limits are determined by the external pressure drop.

COMPACT Unit	Min. flow rate		Max. flow rate	
	m³/h*	m³/s	m³/h*	m³/s
02	300	0.08	900	0.25
03	300	0.08	1440	0.40

* When adjusting the flow, round off the value to the nearest settable step.

Sizing

COMPACT Unit

Delivery and transport within the site

The air handling unit is delivered on a wooden pallet. The inspection door and fans can be dismantled from the unit to make it easier to transport the unit within the site.

The COMPACT Unit is produced in one single variant in which all the components are arranged at their given physical location inside the unit.

The air handling unit is supplied in the right-hand version. The unit can be changed to the left-hand version at the building site by making a simple adjustment in the control equipment. The air handling unit can also be upended and which enables six different installation options as illustrated in the figure to the right.

The design of the COMPACT Unit makes it necessary to mount it on a stand (available as accessories) or some other form of base. Otherwise it will not be possible to open the inspection doors. Swegon's stand is specially designed and among other features has slots for the hinges if the unit is installed vertically.

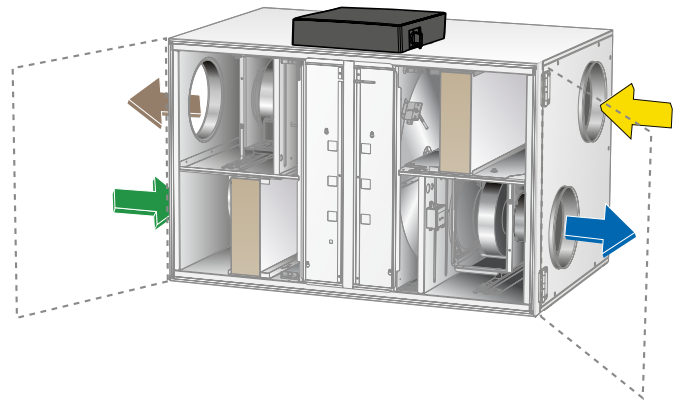

Right-hand version

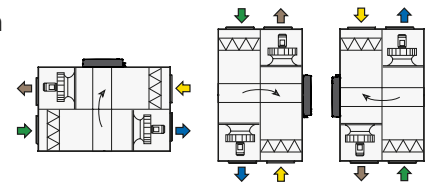

Left-hand version

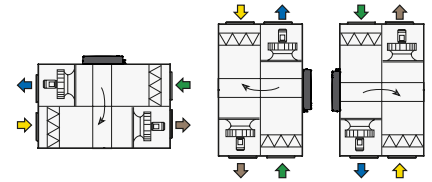

Electrical Data

Power supply

1-phase, 3-wire, 230 V -10/+15%, 50 Hz, 10 AT.
The unit is equipped with a main switch.

Rated data per fan

Size 02: 1 x 230 V, 50/60 Hz, 0.4 kW (0.24 kW)*

Size 03: 1 x 230 V, 50/60 Hz, 0.4 kW

*) The motor controls limit the output power to the value specified.

Rated data for the heat exchanger drive motor

Step motor, 3-phase, 5.8 A (2A)*, 62 V max 90 V.

*) The motor control system limits the output power to the value specified.



COMPACT Unit & Top

Dimensions and Weights

COMPACT Unit, sizes 02 and 03.

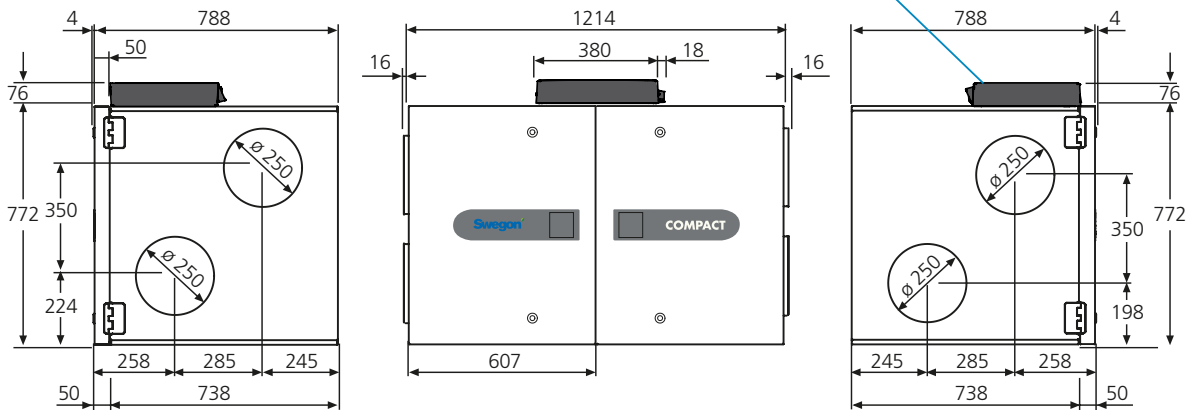

Weight

159-167 kg

Clear Space for Inspection

A clear space of 800 mm must be provided in front of the unit for opening the inspection doors and at least 200 mm must be provided above the unit for opening the junction hood.

Sizing

COMPACT Top, size 02

STE

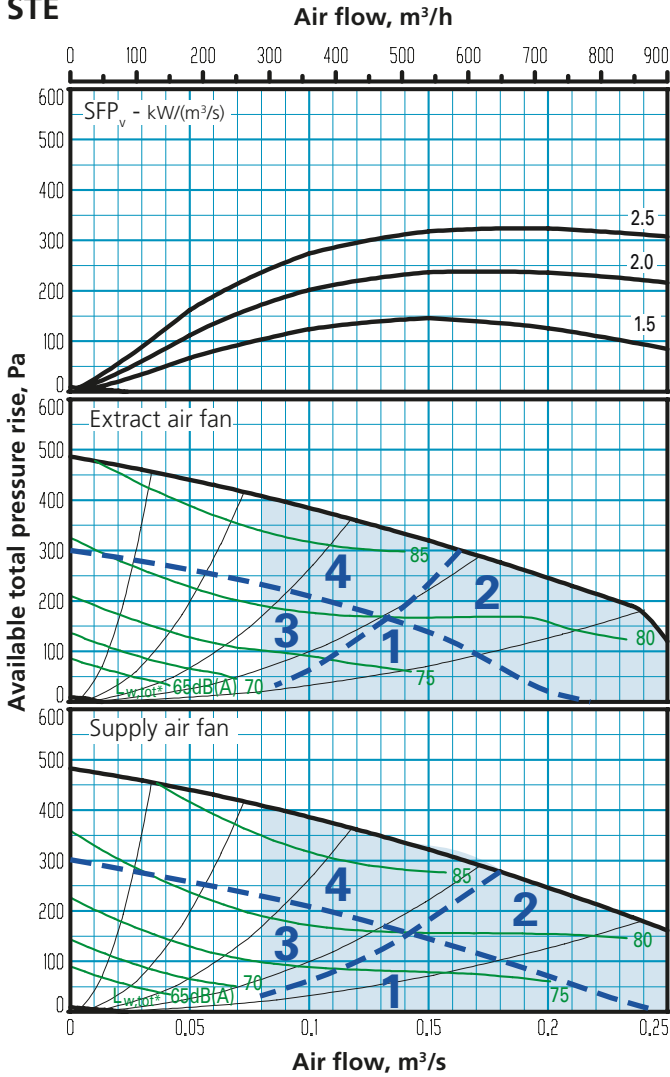

The air handling units comply with requirements to Ecodesign 2018.

COMPACT Top, size 03

STE

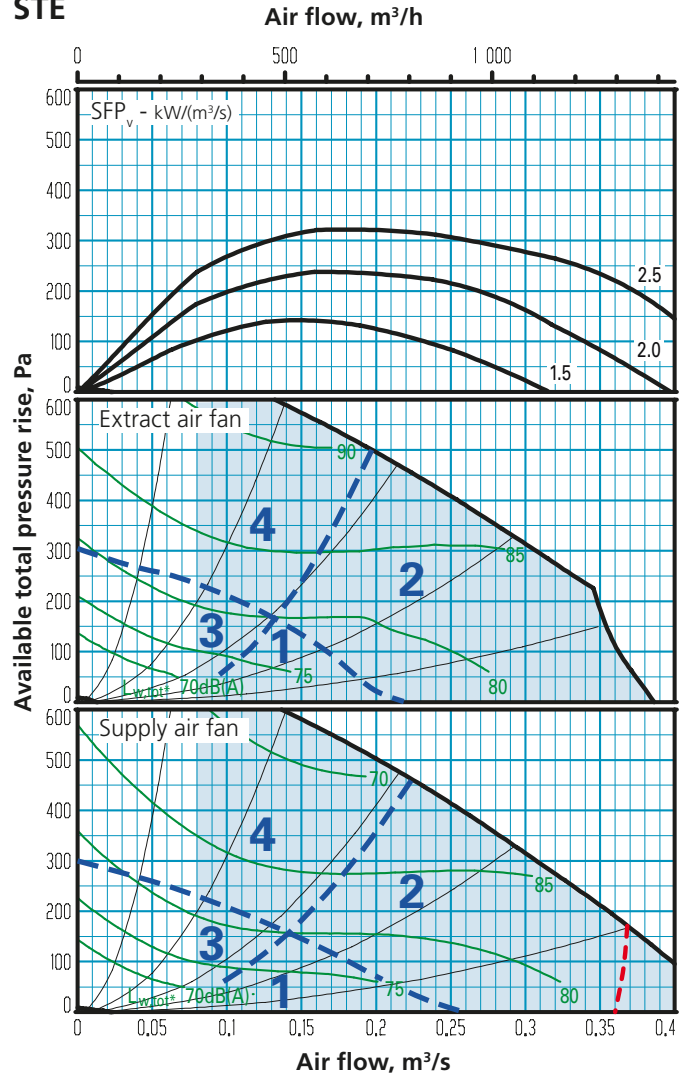

For Ecodesign, the mean value for supply air and extract air must be within the limit line.

--- Limit line, Ecodesign, 2018

COMPACT Unit Correction factors, K_{OK} , dB

Sound path	Range in the diagram	Octave band, no./mid-frequency, Hz							
		1	2	3	4	5	6	7	8
		63	125	250	500	1000	2000	4000	8000
To the outlet duct	1	-1	-1	-10	-15	-16	-17	-23	-26
	2	1	-5	-3	-12	-14	-15	-20	-19
	3	0	-1	-10	-21	-21	-23	-30	-36
	4	-2	-4	-3	-17	-18	-19	-24	-28
To the inlet duct*	1	-4	7	-9	-21	-21	-22	-24	-34
	2	-5	-5	0	-19	-18	-21	-23	-28
	3	1	2	-12	-24	-25	-28	-31	-42
	4	-2	-2	-2	-20	-22	-25	-25	-35
To air handling unit's surroundings**	1	-12	-15	-30	-36	-42	-50	-54	-57
	2	-10	-19	-23	-33	-40	-48	-51	-50
	3	-11	-15	-30	-42	-47	-56	-61	-67
	4	-13	-18	-23	-38	-44	-52	-55	-59

Min. and max. air flows, COMPACT Top

The tabulated flows are those that are possible to set. The practical flow limits are determined by the external pressure drop.

COMPACT Top	Min. flow rate		Max. flow rate	
	m³/h*	m³/s	m³/h*	m³/s
02	300	0.08	900	0.25
03	300	0.08	1440	0.40

* When adjusting the flow, round off the value to the nearest settable step.

Sizing

COMPACT Top

Delivery and transport within the site

The air handling unit is delivered on a wooden pallet. The unit is equipped with base beams.

The inspection door and fans can be dismantled from the unit to make it easier to transport the unit within the site.

The COMPACT Top unit is produced in one single variant in which all the components are arranged at their given physical location inside the unit. All the duct connections are arranged from the top of the air handling unit.

Electrical Data

Power supply

1-phase, 3-wire, 230 V -10/+15%, 50 Hz, 10 AT.
The unit is equipped with a main switch.

Rated data per fan

Size 02: 1 x 230 V, 50/60 Hz, 0.4 kW (0.24 kW)*
Size 03: 1 x 230 V, 50/60 Hz, 0.4 kW

*) The motor controls limit the output power to the value specified.

Rated data for the heat exchanger drive motor

Step motor, 3-phase, 5.8 A (2A)*, 62 V max 90 V.

*) The motor control system limits the output power to the value specified.

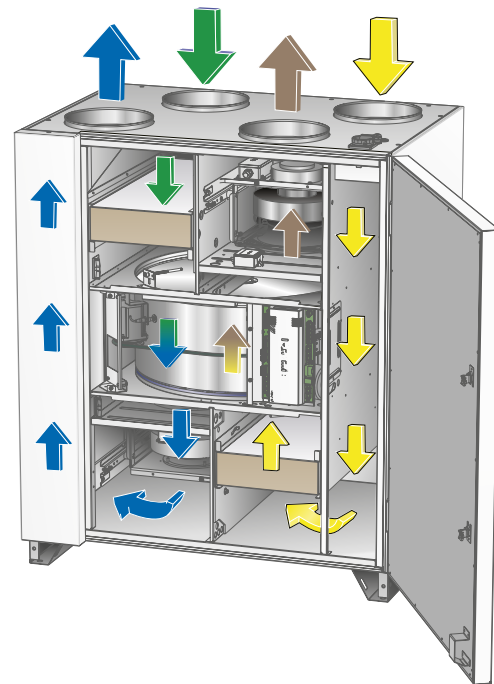

COMPACT Unit & Top

Dimensions and Weights

COMPACT Top, sizes 02 and 03.

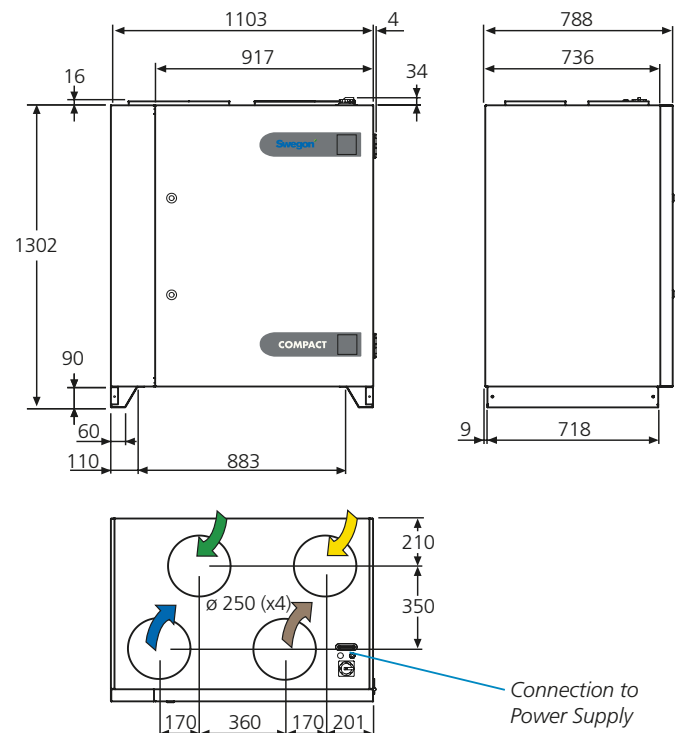

Weight

199-207 kg

Clear Space for Inspection

A clear space of 1,000 mm should be provided in front of the unit for opening the inspection door (right hung).

