

# Commissioning Guide

Version 2013:07

---

---

Air diffusers  
Flow control  
Climate systems



<b>Measurement and commissioning</b>	<b>5-6</b>	<b>Air diffusers with commissioning box TRG</b>	<b>21-22</b>
<b>Air diffusers with commissioning box ALS</b>	<b>7-17</b>	ALG	21
ALC	8	GRL	22
CBE	8	GTH	22
CDD	8	<b>Air diffusers with circular commissioning box</b>	<b>23-24</b>
CDK	9	ACD	23
CDR	9	EAGLE F	24
CKD	10	LOCKZONE F	24
CKP	10	<b>Displacement units</b>	<b>25-27</b>
CVH	11	DBC	25
DPG	11	DBR	25
EAGLE S/D	11	DCP	26
EIV	11	DHC	26
LOCKZONE B	12	DVC	26
LPA	12	ICP	26
ROC	12	IHC	26
COLIBRI CC	13	IVC	26
COLIBRI CR	14	DIR	27
EAGLE C	15	DKC	27
HAWK C	16	DRC	27
LOCKZONE C	17	DRI	27
PELICAN CS/CE	18	<b>Home air diffusers</b>	<b>28</b>
<b>Air diffusers with commissioning box ALV</b>	<b>19-21</b>	DOMO	28
COLIBRI W	19	<b>Diffuser beam with discs and adjustable measuring unit</b>	<b>28</b>
EAGLE W	19	IBIS C	28
LOCKZONE W	20		
PELICAN W	20		
ROW	20		

<b>Slot diffusers</b>	<b>29</b>	<b>Climate systems</b>	<b>37</b>
SLAT 1 SLA	29	<b>Climate beams and comfort modules</b>	<b>38-57</b>
STAT 2 SLA	29	ADRIATIC VF	38
<b>Linear disc diffuser with commissioning box</b>	<b>30</b>	PACIFIC	42
SRYT 1 SRY	30	PARAGON / PARAGON WALL	44
SRYT 2 SRY	30	PARASOL 600 MF	46
<b>Extract air diffusers</b>	<b>31-32</b>	PARASOL 1200 LF/MF	47
EXC	31	PARASOL 1200 HF/PF	48
ROE	32	PARASOL EX 690	50
<b>Flow control</b>	<b>33-36</b>	PARASOL EX 1290 MF/HF	51
VAR	33	ADAPT Parasol	52
IRIS	35	ADAPT Parasol 600/600 PF	53
CRM 1	36	ADAPT Parasol 1200/1200 PF	54
CRM 5	36	ADAPT Parasol EX	55
		ADAPT Parasol EX 690	56
		ADAPT Parasol EX 1290	57

## Measurement and commissioning

---

This commissioning guide shows the measurement instructions for measurable ventilation products made by Swegon AB.

The products are equipped with adjustable dampers and measuring units, which are designed to measure a reference pressure.

### Measurement instructions:

There are several different ways to measure a product. It depends on the product and the design of the measuring function:

- Ductwork with fixed measuring unit.
- Exhaust air terminals with fixed measuring units.
- Supply air terminals with fixed measuring units.

In this commissioning guide you will find these three categories.

Most of the products have measuring tubes connected to the measuring units. The tubes can easily be reached through the front of the terminal device. Some products have one tube and some have two tubes.

A few products have what we call a "nipple well" with a cover. The cover should be shut when balancing has been done.

Some of the flow control products do not have any measuring tubes. Instead you reach the measuring unit easily.

All the products documented together with commissioning boxes ALS, ALV and TRG must be measured together with the commissioning boxes as the measuring units are placed within those.

### Procedure:

1. Define the k-factor for the specific terminal by using the tables in this commissioning guide.
2. Connect the manometer to the measuring tube(s), (measuring units, nipple well).
3. The manometer gives you a measurement pressure,  $p_i$  (balancing pressure).
4. The airflow can now be calculated according to the equation on next page.
5. Adjust the damper to change the airflow. A few of the products do not have ordinary dampers. Instead you use adjustable slot openings or plastic plugs.
6. Lock the damper regulator.

When the correct flow/pressure has been achieved the damper regulator should be locked in one of the following ways:

### Supply air diffusers:

1. In air terminals in which the damper position adjustment control consists of one white and one black nylon cord, the outstretched cords should be tied together to form a so-called commissioning knot. Doing so ensures that the preset damper position is always indicated
2. Wind the cords one turn around the locking screw provided in the product. Lock the damper position by tightening the screw.

### Extract air diffusers:

Takes place analogous to the supply airflow. If the air device is an air extract air register, the position of the cone can be locked in position by tightening a wing nut on the rear side of the air register.

### Kanalprodukter:

On the duct products in which measurement/commissioning takes place according to Method A2, the damper knob is equipped with a locking device.

### Calculation of airflow – k-factor equations:

There is a specific balancing factor, k-factor, for each measurable Swegon product.

The products are normally marked with a k-factor.

The following equations are used to obtain the actual airflow or the balancing pressure that is valid for the designed airflow.

$$q = k \cdot \sqrt{p_i} \quad (\text{l/s})$$

q = measured airflow (l/s)

$p_i$  = actual balancing pressure (Pa)

k = k-factor

$$p_i = \left( \frac{q}{k} \right)^2 \quad (\text{Pa})$$

$p_i$  = balancing pressure at designed airflow (Pa)

q = designed airflow (l/s)

k = k-factor

If temperature and atmospheric pressure differ from standard settings (20 °C and 1013 mbar) at the time of commissioning, the balancing pressure is recalculated according to the following equation:

$$p_i = p_{i, \text{measured}} \cdot \frac{1,2}{\rho_{\text{time of measurement}}} \quad (\text{Pa})$$

Or the airflow can be recalculated to the standard settings according to:

$$q = q_{\text{measured}} \cdot \sqrt{\frac{1,2}{\rho_{\text{time of measurement}}}} \quad (\text{Pa})$$

## Air diffusers

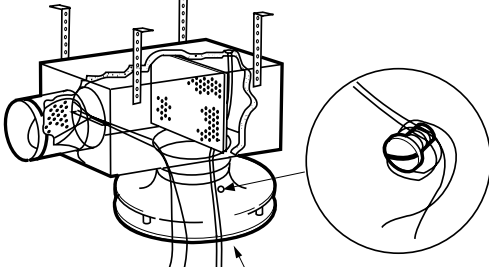

Figure 1. Measurement with one tube.

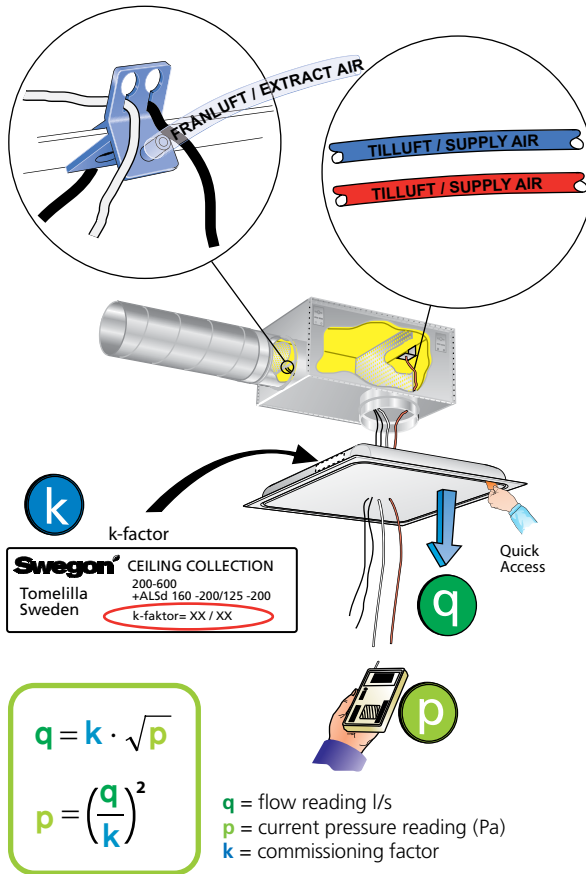

Figure 2. Measurement with two tubes, Ceiling Collection.



ALCa

ALSd	ALBATROSS ALCa		
Size	Size	Supply air	Tube colour
200-250	250	30,1	Red
250-315	315	42,6	Red
315-400	400	59,4	Red
400-500	500	78,2	Red
500-630	630	153,0	Red
1 measuring tube			



CBEa

ALSd	CBEa		
Size	Size	Supply air	Tube colour
80-100	100	4,6	Red
100-125	125	7,3	Red
125-160	160	11,9	Red
1 measuring tube			



CDDb

ALSd	CDDb supply air 360°				
Size	Size	Slot 20 mm	Slot 30 mm	Slot 40 mm	Tube colour
80-100	100	5,8	6,1	–	Red
100-125	125	8,2	8,9	–	Red
125-160	160	–	14,4	15,0	Red
160-200	200	–	21,3	23,4	Red
200-250	250	–	24,4	31,1	Red
250-315	315	–	34,6	43,3	Red
1 measuring tube					





CDKa

ALSd	CDKa supply air 360°				
Size	Size	Slot 20 mm	Slot 30 mm	Slot 40 mm	Tube colour
80-100	100	6,8	6,9	–	Red
100-125	125	9,8	10,1	–	Red
125-160	160		16,3		Red
160-200	200	–	26,9	27,6	Red
200-250	250	–	38,5	42,1	Red
250-315	315	–	57,6	69,9	Red
1 measuring tube					



CDRb

ALSd	CDRb supply air 360°				
Size	Size	Slot 20 mm	Slot 30 mm	Slot 40 mm	Tube colour
80-100	100	5,0	5,6	–	Red
100-125	125	7,1	8,1	–	Red
125-160	160	–	13,1	13,9	Red
160-200	200	–	18,4	20,3	Red
200-250	250	–	24,3	28,5	Red
250-315	315	–	36,1	42,6	Red
1 measuring tube					



CKDa

ALSd	CKDa supply air			
Size	Size	Diffused	Concentrated	Tube colour
160-200	200	13,9	12,6	Red
200-250	250	22,8	21,1	Red
250-315	315	34,7	32,3	Red
315-400	400	55,8	52,9	Red
1 measuring tube				



CKPa

ALSd	CKPa supply air 360°				
Size	Size	Slot 20 mm	Slot 30 mm	Slot 40 mm	Tube colour
80-100	100	3,8	6,8	–	Red
100-125	125	9,9	10,1	–	Red
125-160	160	–	16,2	16,5	Red
160-200	200	–	27,3	27,9	Red
200-250	250	–	39,8	42,2	Red
250-315	315	–	60,6	68,7	Red
1 measuring tube					



CVHb

ALSd	CVHb supply air 360°			
Size	Size	Horizontal	Vertical	Tube colour
100-125	125	8,9	8,3	Red
125-160	160	13,5	11,8	Red
160-200	200	22,3	16,8	Red
200-250	250	33,9	24,3	Red
250-315	315	52,4	37,7	Red
315-400	400	79,8	58,7	Red
1 measuring tube				



DPGa

ALSd	DPGa		
Size	Size	Supply air	Tube colour
100-125	125-0	3,8	Red
1 measuring tube			



EAGLE S/D a

ALSd	EAGLE S/D supply air		
Size	EAGLE S	EAGLE D	Tube colour
100-125	7,5	8,1	Red
125-160	12,1	13,5	Red
160-200	20,1	22,2	Red
200-250	29,8	33,5	Red
250-315	42,3	50,4	Red
315-400	67,8	79,6	Red
1 measuring tube			



EIVa

ALSd	EIVa		
Size	Size	Supply air	Tube colour
80-80	80	4,6	Red
80-100	100	5,9	Red
100-125	125	8,2	Red
125-160	160	10,3	Red
1 measuring tube			



LOCKZONE Ba

ALSd	LOCKZONE Ba		
Size	Size	Supply air	Tube colour
80-100	100	2,7	Red
100-125	125	3,7	Red
125-160	160	5,6	Red
1 measuring tube			



LPAa

ALSd	LPAa	Supply air		Extract air	
Size	Size	Supply air	Tube colour	Extract air	Tube colour
125-160	160	11,0	Röd	7,0	Transparent
160-200	200	18,1	Röd	11,5	Transparent
200-250	250	27,5	Röd	17,7	Transparent
250-315	315	38,0	Röd	28,5	Transparent
315-400	400	58,7	Röd	41,6	Transparent
1 measuring tube			1 measuring tube		



ROCa

ALSd	ROCa	Supply air		Extract air	
Size	Size	Supply air	Tube colour	Extract air	Tube colour
100-125	125	7,1	Red	4,6	Transparent
125-160	160	11,2	Red	7,0	Transparent
1 measuring tube			1 measuring tube		



**COLIBRI CCa**

<b>ALSd</b>	<b>COLIBRI CCa supply air</b>			
Size	Size	Standard	Low version	Tube colour
100-125	125-400	7,3	7,0	Red
100-125	125-600	7,3	7,0	Red
100-160	160-400	9,3	8,9	Blue
100-160	160-600	9,3	8,9	Blue
125-160	160-400	9,8	9,3	Red
125-160	160-600	9,8	9,3	Red
125-200	200-500	15,6	14,5	Blue
125-200	200-600	15,6	14,5	Blue
160-200	200-500	16,8	15,2	Red
160-200	200-600	16,8	15,0	Red
160-250	250-600	23,4	21,7	Blue
200-250	250-600	24,9	22,8	Red
200-315	315-600	26,4	25,4	Blue
250-315	315-600	27,4	25,6	Red
315-400	400-600	32,5	-	Red
1 measuring tube				

<b>ALSd</b>	<b>COLIBRI CCa extract air</b>		
Size	Size	Standard	Tube colour
200-250	250-600	14,4	Transparent
250-315	315-600	18,7	Transparent
315-400	400-600	25,5	Transparent
1 measuring tube			



**COLIBRI CRa**

<b>ALSd</b>	<b>COLIBRI CRa supply air</b>			
Size	Size	Standard	Low version	Tube colour
100-125	125-400	7,4	7,2	Red
100-125	125-600	7,4	7,2	Red
100-160	160-400	9,5	9,2	Blue
100-160	160-600	9,5	9,2	Blue
125-160	160-400	10,0	9,6	Red
125-160	160-600	10,0	9,6	Red
125-200	200-500	16,7	15,5	Blue
125-200	200-600	16,7	15,5	Blue
160-200	200-500	17,7	16,5	Red
160-200	200-600	17,7	16,5	Red
160-250	250-600	26,4	24,7	Blue
200-250	250-600	28,9	26,4	Red
200-315	315-600	30,3	28,6	Blue
250-315	315-600	32,1	29,5	Red
315-400	400-600	37,7	-	Red
1 measuring tube				

<b>ALSd</b>	<b>COLIBRI CRa extract air</b>		
Size	Size	Standard	Tube colour
200-250	250-600	16,2	Transparent
250-315	315-600	21,2	Transparent
315-400	400-600	29,1	Transparent
1 measuring tube			



EAGLE Ca

ALSd	EAGLE Ca supply air			
Size	Size	Standard	Low version	Tube colour
100-125	125-400	7,8	7,6	Red
100-125	125-600	7,7	7,6	Red
100-160	160-400	11,8	11,5	Blue
100-160	160-600	11,8	11,2	Blue
125-160	160-400	12,6	11,9	Red
125-160	160-600	12,6	11,7	Red
125-200	200-500	17,6	16,9	Blue
125-200	200-600	17,6	16,7	Blue
160-200	200-500	19,9	17,9	Red
160-200	200-600	19,9	17,9	Red
160-250	250-600	26,5	24,1	Blue
200-250	250-600	28,2	25,9	Red
200-315	315-600	35,2	32,2	Blue
250-315	315-600	37,3	33,5	Red
315-400	400-600	53,1	–	Red
1 measuring tube				

ALSd	EAGLE Ca extract air		
Size	Size	Standard	Tube colour
200-250	250-600	18,6	Transparent
250-315	315-600	26,4	Transparent
315-400	400-600	39,6	Transparent
1 measuring tube			



**HAWK Ca**

<b>ALSd</b>	<b>HAWK Ca supply air</b>			
Size	Size	Standard	Low version	Tube colour
100-125	125-600	8,4	8,0	Red
100-160	160-600	11,7	10,9	Blue
125-160	160-600	12,3	11,9	Red
125-200	200-600	19,1	17,0	Blue
160-200	200-600	20,9	18,2	Red
160-250	250-600	29,1	25,7	Blue
200-250	250-600	32,5	28,5	Red
200-315	315-600	37,0	34,2	Blue
250-315	315-600	39,4	35,3	Red
315-400	400-600	50,9	-	Red
1 measuring tube				

<b>ALSd</b>	<b>HAWK Ca extract air</b>		
Size	Size	Standard	Tube colour
200-250	250-600	19,1	Transparent
250-315	315-600	25,4	Transparent
315-400	400-600	34,9	Transparent
1 measuring tube			





**LOCKZONE Ca**

<b>ALSd</b>	<b>LOCKZONE Ca supply air</b>			
Size	Size	Standard	Low version	Tube colour
100-125	125-400	8,3	7,9	Red
100-125	125-600	8,2	7,8	Red
100-160	160-400	11,1	10,8	Blue
100-160	160-600	11,2	10,8	Blue
125-160	160-400	12,1	11,4	Red
125-160	160-600	12,4	11,4	Red
125-200	200-500	18,0	16,9	Blue
125-200	200-600	17,8	16,9	Blue
160-200	200-500	19,7	18,4	Red
160-200	200-600	19,7	18,0	Red
160-250	250-600	28,1	25,6	Blue
200-250	250-600	30,9	27,4	Red
200-315	315-600	36,5	35,1	Blue
250-315	315-600	39,6	39,6	Red
315-400	400-600	56	–	Red
1 measuring tube				

<b>ALSd</b>	<b>LOCKZONE Ca extract air</b>		
Size	Size	Standard	Tube colour
200-250	250-600	18,4	Transparent
250-315	315-600	27,1	Transparent
315-400	400-600	42,5	Transparent
1 measuring tube			



## PELICAN CSa

<b>ALSd</b>	<b>PELICAN CSa supply air</b>			
Size	Size	Standard	Low version	Tube colour
100-125	125-400	7,1	7,7	Red + Red
100-160	160-400	10,6	10,1	Blue + Red
125-160	160-400	11,4	11,8	Red + Red
125-200	200-600	16,0	16,5	Blue + Red
160-200	200-600	18,1	19,0	Red + Red
160-250	250-600	25,7	27,1	Blue + Red
200-250	250-600	29,0	28,4	Red + Red
200-315	315-600	37,6	36,1	Blue + Red
250-315	315-600	44,0	38,1	Red + Red
315-400	400-600	68,2	–	Red
2 measuring tubes, NOTE! size 400-600 1 measuring tube				



## PELICAN CEa

<b>ALSd</b>	<b>PELICAN CEa extract air</b>			
Size	Size	Standard	Low version	Tube colour
100-125	125-400	4,9	4,6	Transparent
125-160	160-400	7,6	7,2	Transparent
160-200	200-600	14,2	12,6	Transparent
200-250	250-600	21,2	20,2	Transparent
250-315	315-600	27,9	27,7	Transparent
315-400	400-600	41,6	–	Transparent
1 measuring tube				

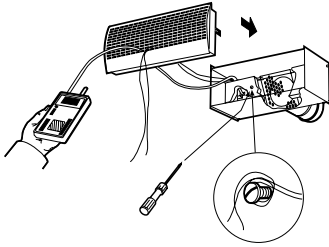

Figure 1. Measurement with one tube.

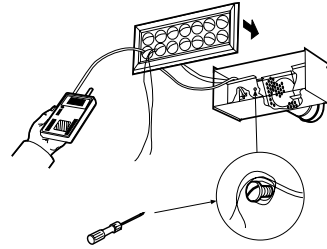

Figure 2. Measurement with one tube.



## COLIBRI Wa

ALVd	COLIBRI Wall supply air				
		Back side connection		Short side connection	
Size	Size	Closed slot	Open slot	Closed slot	Open slot
300-150-100	300-150	5,4	7,1	5,1	6,6
400-150-125	400-150	7,8	9,9	7,6	9,4
400-200-160	400-200	10,2	12,7	10,1	12,4
550-250-200	550-250	16,9	20,5	16,5	20
550-300-250	550-300	19,8	23,7	19,6	23,5



## EAGLE Wa

ALVd	EAGLE Wall supply air				
		Back side connection		Short side connection	
Size	Size	Closed slot	Open slot	Closed slot	Open slot
300-150-100	300-100	7,8	9,2	7,2	8,1
400-150-125	400-150	9,9	11,8	9,6	11,1
400-200-160	400-200	14,8	17,1	14	15,9
550-250-200	550-250	25,5	27,8	24,4	26,8
550-300-250	550-300	31,1	33,9	30,5	33,4



### LOCKZONE Wa

ALVd	LOCKZONE Wall supply air	
Size	Back side connection	Short side connection
300-150	7,4	6,9
400-150	10	9,9
400-200	15	14,3
550-250	26,3	24,9
550-300	32,4	32



### PELICAN Wa

ALVd	PELICAN Wall supply air		
Size	Size	Back side connection	Short side connection
300-150-100	300-100	8,8	8,1
400-150-125	400-150	10,9	11,1
400-200-160	400-200	17,3	17,3
550-250-200	550-250	25,6	25,1
550-300-250	550-300	32,2	32,6



### ROWb

ALVd	ROWb supply air	
Size	Back side connection	Short side connection
400-150-125-B	400-150	10,0
400-200-160-B	400-200	15,0

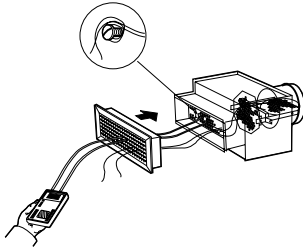
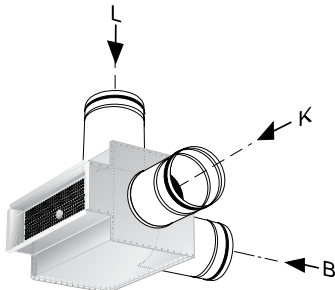

Figure 1. Measurement with two tubes.



TRGc	ALGc supply air			ALGc extract air		
	Connection			Connection		
Size	B	K	L	B	K	L
200-100-125	7,2	7,1	7,4	7,6	7,7	7,2
300-100-160	11,9	12,2	12,3	13,4	13,0	12,3
400-100-160	15,9	16,2	15,5	19,3	18,2	17,4
500-100-200	21,4	21,4	22,2	23,2	23,0	21,2
300-150-200	19,6	19,4	20,2	20,9	21,4	19,2
400-150-250	26,9	26,3	27,3	28,9	28,2	26,4
500-150-250	35,0	34,5	32,4	36,3	35,7	33,3
400-200-250	36,8	38,5	42,0	45,6	44,3	41,0
500-200-315	52,4	50,8	48,5	56,3	56,1	51,5
600-200-315	61,9	60,7	57,6	70,7	69,6	61,0

2 measuring tubes.  
 Connection alternatives B= Back side, K = Short side, L = Long side



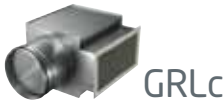

TRGc	GRLc extract air		
	Connection		
Storlek	B = back side	K = short side	L = long side
200-100-125	7,9	8,5	7,0
300-100-160	13,3	13,2	11,8
400-100-160	18,9	18,5	16,9
500-100-200	23,2	23,3	21,0
300-150-200	21,0	20,9	18,5
400-150-250	29,1	28,4	25,3
500-150-250	36,6	35,7	32,4
400-200-250	46,6	42,9	39,8
500-200-315	56,8	55,4	47,9
600-200-315	70,0	68,5	59,4
600-300-400	109,0	107,0	104,0

2 measuring tubes



TRGc	GTHc supply air, straight blades			GTHc supply air, blades 45°		
	Connection			Connection		
Size	B	K	L	B	K	L
200-100-125	7,5	7,2	7,3	7,2	7,0	7,1
300-100-160	12,1	12,1	12,3	11,3	11,9	12,1
400-100-160	16,2	16,6	15,4	15,0	16,1	15,0
500-100-200	21,1	20,7	22,1	20,1	20,4	21,1
300-150-200	19,3	19,2	19,7	19,4	18,8	19,2
400-150-250	26,5	26,1	27,9	25,4	25,8	26,6
500-150-250	34,8	33,5	32,9	33,8	33,4	30,9
400-200-250	38,1	39,2	41,2	37,4	38,1	41,1
500-200-315	50,5	48,4	48,3	48,0	48,2	46,4
600-200-315	60,3	58,7	56,6	57,6	57,8	54,4

2 measuring tubes  
 Connection alternatives: B = Back side, K = Short side, L = Long side

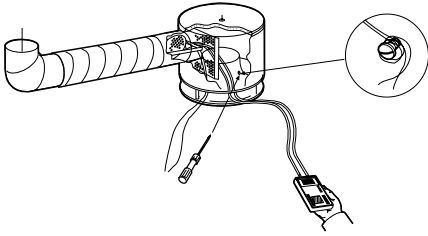

Figure 1. Measurement with two tubes.

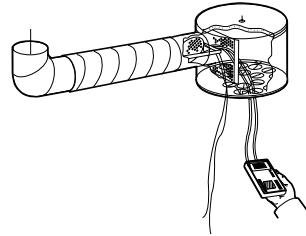

Figure 2. Measurement with two tubes.

Straight sections are required before the diffuser to secure that the stated method errors, 5 %, will be obtained, see table:

1 · 90° bend	3 · Ød
2 · 90° bend	4 · Ød
T-joint	4 · Ød
Damper 45°	6 · Ød



ACDa

Size	ACDa supply air		
	Slot 20 mm	Slot 30 mm	Slot 40 mm
100	5,5	5,5	–
125	8,9	8,9	–
160	–	15,5	15,5
200	–	25,8	25,8
250	–	39,6	39,6
315	–	67,4	67,4
2 measuring tubes. Spread pattern: 360°			



EAGLE Fb

Size	EAGLE Fb supply air		EAGLE Fb extract air	
	k-factor	Tube colour	K-factor	Tube colour
100	5,2	Blue + transparent	7,0	Transparent
125	8,2	Blue + transparent	11,4	Transparent
160	14,8	Blue + transparent	16,6	Transparent
200	24,5	Blue + transparent	26,0	Transparent
250	36,9	Blue + transparent	36,0	Transparent
315	62,6	Blue + transparent	46,0	Transparent
400	101,0	Blue + transparent	74,0	Transparent
2 measuring tubes			1 measuring tube	



LOCKZONE Fa

Size	LOCKZONE Fa supply air	
	Slot 20 mm	Slot 30 mm
125	14,1	15,2
160	23,4	25,7
200	35,1	38,6
250	51,5	56,7
315	74,5	83,1
1 measuring tube Spread pattern: 360° No straight section required.		



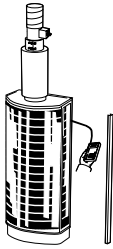
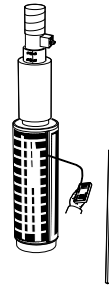

Figure 1. DBC, DHC, DVC. Measurement with one tube.



Figur 2. DCP. Measurement with one tube.



DBCa



DBRe

	<b>DBCa</b>	<b>DBRe</b>
Size	Supply air	Supply air
200	34,0	36,8
250	54,0	41,0
315	89,5	46,5
400	142,5	–
200-600	122,0	–
300-600	185,0	–
1 measuring tube.		

## Displacement units



DCPe



DHCe



DVCe

	<b>DCPe</b>	<b>DHCe</b>	<b>DVCe</b>
Size	Supply air	Supply air	Supply air
125	12,2	12,0	12,0
160	22,8	20,0	20,0
200	37,0	33,0	33,0
250	58,0	50,0	50,0
315	88,0	84,0	84,0
400	141,0	134,0	134,0
500	210,0	202,0	–
630	295,0	285,0	–
800	–	520,0	–
1 measuring tube			



ICPa



IHCa



IVCa

	<b>ICPa</b>	<b>IHCa</b>	<b>IVCa</b>
Size	Supply air	Supply air	Supply air
200	22,9	22,9	22,9
250	35,9	35,9	35,9
315	54,4	54,4	54,4
1 measuring tube			

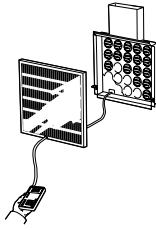

Figure 3. DIR. Measurement with one tube.

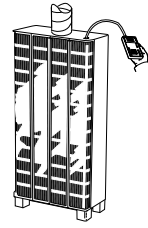

Figure 4. DRC and DKC. Measurement with one tube.

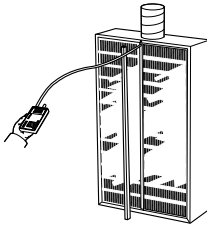

Figure 5. DRI. Measurement with one tube.



	<b>DIRc</b>	<b>DKCe</b>	<b>DRCe</b>	<b>DRIf</b>
Size	Supply air	Supply air	Supply air	Supply air
400-100	13,1	–	–	–
500-125	18,7	–	–	–
600-160	23,5	–	–	–
900-200	46,8	–	–	–
200	–	–	32,0	32,0
250	–	–	53,0	53,0
315	–	–	85,0	85,0
400	–	–	130,0	130,0
200-600	–	–	120,0	120,0
250-800	–	–	176,0	176,0
500	–	133,0	–	–
630	–	223,0	–	–
800	–	350,0	–	–
1 measuring tube				



DOMO b

DOMO b	
Adjustment	k-factor
R 1	1,3
R 2	2,3
R 3	3,3
R 4	3,9



IBIS Ca

Adjustable measuring unit IBIS Ca	
Size	k-factor
160-1500	14,8
200-1500	22,5
250-1500	36,1
315-1500	61,2
400-1500	96
2 measuring tubes	



SLAa

SLAT1	SLAa supply air	
Size	90°	0°
2-600	7,1	7,9
4-600	14,8	17,5
6-600	22,0	27,5
2-900	10,6	12,5
4-900	21,2	25,3
6-900	29,4	35,4
1 measuring tube		



SLAa

SLAT2	SLAa supply air	
Size	90°	0°
2-600	7,5	9,2
4-600	15,0	18,4
6-600	22,5	27,6
2-900	11,0	13,8
4-900	22,0	27,6
6-900	33,0	41,4
1 measuring tube		



SRYb

SRYT 1b	SRYb			
Size	Size	Supply air	Size	Supply air
1-500-125-L	1-900-1	4,5	1-1200-1	5,3
2-500-160-L	2-900-1	8,6	2-1200-2	6,5
3-500-160-L	3-900-1	12,4	3-1200-2	9,4
4-500-200-L	4-900-1	16,2	4-1200-2	12,4

1 measuring tube

Note! The K-factor is valid for one commissioning box.

Ex: With two or three commissioning boxes for one diffuser, the total of the designed airflow shall be divided by the number of commissioning boxes.



SRYb

SRYT 2b	SRYb			
Size	Size	Supply air	Size	Supply air
1-500-125-L	1-1500-2	4,2	1-1800-2	4,6
2-500-160-L	2-1500-2	7,8	2-1800-2	8,6
3-500-160-L	3-1500-2	11,4	3-1800-2	13,0
4-500-200-L	4-1500-2	14,4	4-1800-3	12,4

1 measuring tube

Note! The K-factor is valid for one commissioning box.

Ex: With two or three commissioning boxes for one diffuser, the total of the designed airflow shall be divided by the number of commissioning boxes.

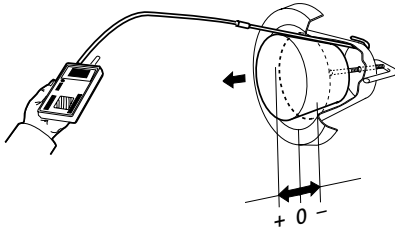

Figure 1. EXC and ROE. Measurement with one tube.



EXCa

	<b>EXCa 100</b>	<b>EXCa 125</b>	<b>EXCa 160</b>	<b>EXCa 200</b>
Cone position	k-factor	k-factor	k-factor	k-factor
-15	0,6	–	–	–
-12	0,8	–	–	–
-10	1,0	1,3	2,0	–
-5	1,4	1,9	2,8	–
-3	–	–	–	1,8
0	1,8	2,6	3,6	2,6
+5	2,3	3,2	4,5	3,8
+10	2,7	3,9	5,4	5,2
+15	–	–	6,2	6,4
+20	–	–	–	7,5
+25	–	–	–	8,6

Measured by pressure gauge.



ROEa

	<b>ROEa 100</b>	<b>ROEa 125</b>	<b>ROEa 160</b>	<b>ROEa 200</b>
Cone position	k-factor	k-factor	k-factor	k-factor
-15	0,6	–	–	–
-12	0,8	–	–	–
-10	1,0	1,3	2,0	–
-5	1,4	1,9	2,8	–
-3	–	–	–	1,8
0	1,8	2,6	3,6	2,6
+5	2,3	3,2	4,5	3,8
+10	2,7	3,9	5,4	5,2
+15	–	–	6,2	6,4
+20	–	–	–	7,5
+25	–	–	–	8,6
Measured by pressure gauge				



## Flow control

Straight sections are required before the damper to secure that stated method errors, 5%, will be obtained, see table:

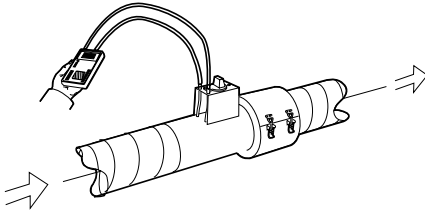

1 · 90° bend	3 · Ød
2 · 90° bends	4 · Ød
1 · T-joint	4 · Ød
Mixing box	4 · Ød

Figure 1. Number of measuring tubes: 2. Connected to "nipple well". The K-factor is also valid for the combination VAR with sound attenuator CLA L=500 or 1000mm.



## VARd circular

Size	VARd 1, 2, 4
100	5,8
125	9,2
160	15,6
200	25,4
250	39,9
315	63,6
400	104
500	165



VARd rectangular

Size	VARd
200-200	33,5
300-200	50,0
400-200	66,5
500-200	83,5
600-200	100,0
700-200	117,0
800-200	133,0
1000-200	167,0
400-300	102,0
500-300	127,0
600-300	152,0
700-300	178,0
800-300	203,0
850-300	216,0
1000-300	254,0
400-400	136,0
500-400	171,0
600-400	205,0
700-400	239,0
800-400	273,0
1000-400	341,0
1200-400	409,0
1400-400	478,0
1600-400	546,0

Size	VARd
500-500	214,0
600-500	257,0
800-500	343,0
1000-500	429,0
1200-500	514,0
1400-500	600,0
1600-500	686,0
600-600	309,0
800-600	412,0
1000-600	515,0
1200-600	618,0
1400-600	722,0
1600-600	825,0
700-700	422,0
800-700	482,0
1000-700	603,0
1200-700	723,0
1400-700	844,0
1600-700	964,0



IRISa

IRIS a, k-factor								
Size	1	1,5	2	2,5	3	3,5	4	4,5
80	6,1	–	4,1	–	3,2	–	2,3	–
100	10,4	7,9	7,5	6,6	6,0	5,2	4,5	3,8
125	13,8	10,4	8,8	7,3	6,5	5,5	4,7	4,0
150	24,1	20,0	16,5	14,9	13,4	12,0	11,0	10,0
160	22,1	17,2	14,8	13,4	12,5	11,5	10,7	9,5
200	44,2	36,6	30,9	26,9	23,2	20,6	18,2	15,9
250	64,4	53,5	45,6	41,8	38,7	34,5	30,7	27,3
315	118,0	88,3	70,0	64,5	58,7	53,0	45,1	42,4
400	131,0	–	102,0	–	88,3	–	67,3	–
500	230,0	–	177,0	–	146,0	–	112,0	–
630	451,0	–	297,0	–	238,0	–	169,0	–
800	489,0	–	402,0	–	344,0	–	267,0	–

IRIS a, k-factor							
Size	5	5,5	6	6,5	7	7,5	8
80	1,4	–	0,9	–	0,6	–	–
100	3,4	2,9	2,5	2,1	1,7	1,2	0,9
125	3,5	3,1	2,7	2,2	1,5	–	–
150	8,9	7,9	6,9	6,0	5,2	4,4	3,7
160	8,5	7,5	6,8	5,6	4,9	4,0	3,5
200	14,0	12,3	11,0	9,6	8,4	6,5	5,0
250	24,1	21,4	18,4	15,8	12,8	10,9	8,9
315	37,0	33,3	30,0	25,9	21,8	19,0	15,8
400	52,7	–	38,5	–	28,4	–	15,5
500	88,5	–	66,6	–	48,0	–	30,0
630	127,0	–	91,6	–	62,8	–	35,1
800	217,0	–	170,0	–	122,0	–	73,7

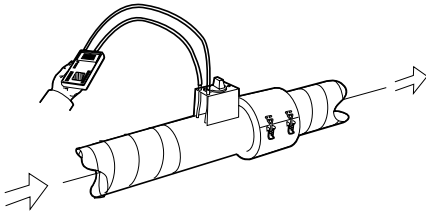

Figure 2. Measurement with two tubes.

Straight sections are required before the damper to secure that the stated method errors, 5%, will be obtained, see table:

1 · 90° bend	3 · Ød
2 · 90° bends	4 · Ød
T-joints	4 · Ød
Damper 45°	6 · Ød



CRMc 1



CRMc 5

Size	CRMc 1	CRMc 5
80	5,0	
100	9,2	9,2
125	9,6	9,6
160	15,8	15,8
200	23,5	23,5
250	35,6	35,6
315	59,2	59,2
400	95,6	95,6
500	147,0	–
630	230,0	–
2 measuring tubes		

### Vattenburna klimatsystem

#### Beräkningsformel

$$q = k \cdot \sqrt{p_i} \quad (\text{l/s})$$

q = primärluftflöde (l/s)

p = injusteringstryck i (Pa)

k = enhetens k-faktor

k-faktorn gäller vid 20 °C och 1013 mbar

#### Mätställe

Samtliga klimatbafflar och komfortmoduler är försedda med mätslang. Vid injustering ansluts en manometer mot mätslangen vars inre diameter är 4 mm.

Mätslangens placering beror på typ av produkt:

- ADRIATIC – mitt på baffeln.
- PARAGON och PACIFIC – vid kanalanslutning.
- PARASOL, Parasol EX, ADAPT Parasol, ADAPT Parasol EX – ett av produktens hörn.



## ADRIATIC VF

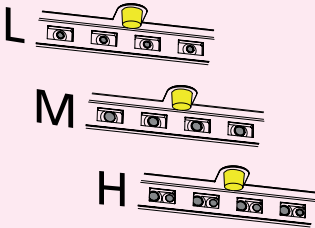
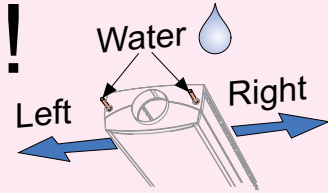

$$q = k \cdot \sqrt{p_i} \text{ [l/s]}$$

$$p_i = (q/k)^2 \text{ [Pa]}$$

$$L: k_{600\text{mm (1side)}} = 0,314$$

$$M: k_{600\text{mm (1side)}} = 0,694$$

$$H: k_{600\text{mm (1side)}} = 0,969$$

1

Rum 203  
ADRIATIC VF b 1,8  
22 l/s

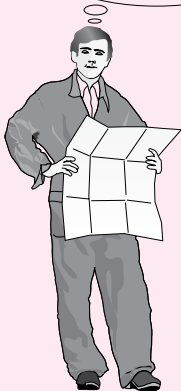

2

ADRIATIC VF b 1,8

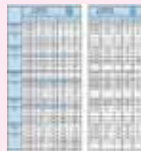

$$q=17,5-26,5 \text{ (l/s)}$$

$$k=3,19$$

$$q_{50\%} \Rightarrow 2LH$$

$$q_{50\%} \Rightarrow 2LH$$

3

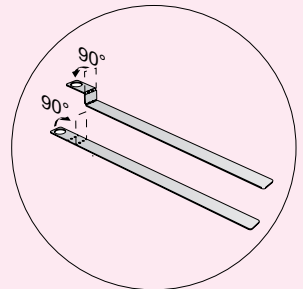
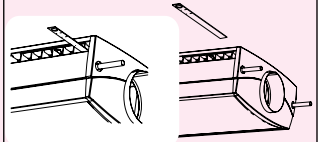



# ADRIATIC VF

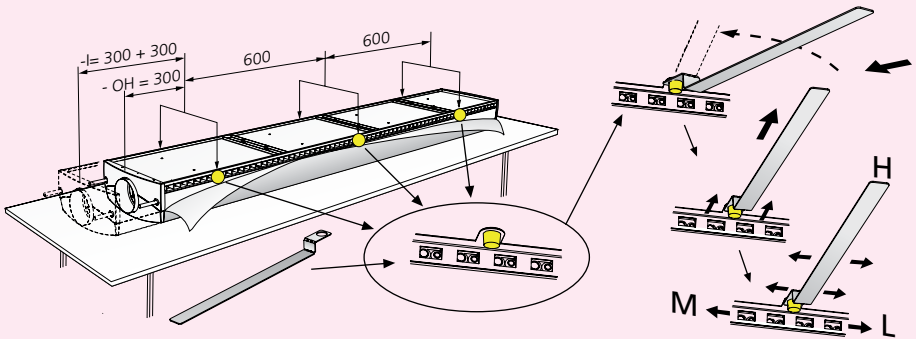
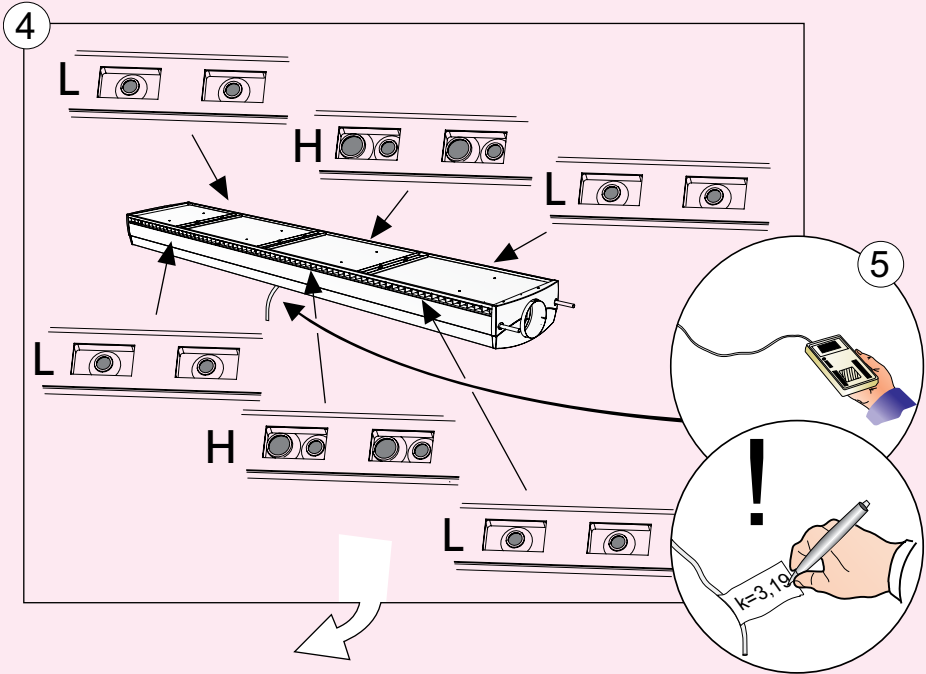

## ADRIATIC VF

	Symmetrisk (q=50%/50%)				
	pi (Pa)	q (l/s)	k	q=50%	q=50%
ADRIATIC VF 1,2-OH	30-70Pa	7-10,5	1,25	2L	2L
	30-70Pa	11-17	2,01	LM	LM
	30-70Pa	14-21,5	2,57	LH	LH
ADRIATIC VF 1,5-I	30-70Pa	15,5-23,5	2,77	2M	2M
	30-70Pa	18,5-27,5	3,33	MH	MH
	30-70Pa	21,5-32,5	3,88	2H	2H
ADRIATIC VF 1,8-OH	30-70Pa	10,5-15,5	1,88	3L	3L
	30-70Pa	14,5-22	2,64	2LM	2LM
	30-70Pa	17,5-26,5	3,19	2LH	2LH
ADRIATIC VF 2,1-I	30-70Pa	21,5-33	3,95	LMH	LMH
	30-70Pa	24,5-37,5	4,5	L2H	L2H
	30-70Pa	28,5-44	5,26	M2H	M2H
ADRIATIC VF 2,4-OH	30-70Pa	31,5-48,5	5,81	3H	3H
	30-70Pa	13,5-21	2,51	4L	4L
	30-70Pa	18-27	3,27	3LM	3LM
ADRIATIC VF 2,7-I	30-70Pa	22-33,5	4,03	2L2M	2L2M
	30-70Pa	26,5-40	4,79	L3M	L3M
	30-70Pa	30,5-46	5,55	4M	4M
ADRIATIC VF 3,0-OH	30-70Pa	36,5-...	6,65	2M2H	2M2H
	30-70Pa	42,5-...	7,75	4H	4H
	30-70Pa	17,5-26	3,14	5L	5L
ADRIATIC VF 3,3-I	30-70Pa	21,5-32,5	3,9	4LM	4LM
	30-70Pa	25,5-38,5	4,66	3L2M	3L2M
	30-70Pa	30-45	5,42	2L3M	2L3M
ADRIATIC VF 3,6-OH	30-70Pa	34-51,5	6,18	L4M	L4M
	30-70Pa	41-...	7,49	4MH	4MH
	30-70Pa	47-...	8,59	2M3H	2M3H
ADRIATIC VF 3,9-I	30-70Pa	20,5-31,5	3,76	6L	6L
	30-70Pa	25-37,5	4,52	5LM	5LM
	30-70Pa	29-44	5,28	4L2M	4L2M
ADRIATIC VF 3,9-I	30-70Pa	33-50,5	6,04	3L3M	3L3M
	30-70Pa	39,5-...	7,14	3LM2H	3LM2H
	30-70Pa	43,5-...	7,9	2L2M2H	2L2M2H
	30-70Pa	47,5-...	8,66	L3M2H	L3M2H





## ADRIATIC VF

Asymmetrisk (q≈70%/30%)				
pi (Pa)	q (l/s)	k	q≈70%	q≈30%
30-70Pa	11-17	2,01	2M	2L
30-70Pa	14-21,5	2,57	2H	2L
30-70Pa	16-24,5	2,95	2H	LM
30-70Pa	14,5-22	2,64	L2M	3L
30-70Pa	19,5-30	3,57	M2H	3L
30-70Pa	21-32	3,85	3H	3L
30-70Pa	23-35,5	4,23	3H	2LM
30-70Pa	25,5-38,5	4,61	3H	L2M
30-70Pa	18-27	3,27	2L2M	4L
30-70Pa	22-33,5	4,03	4M	4L
30-70Pa	25-38	4,58	2M2H	4L
30-70Pa	28-42,5	5,13	4H	4L
30-70Pa	34,5-52	6,27	4H	L3M
30-70Pa	25,5-39	4,66	L4M	5L
30-70Pa	30,5-46,5	5,59	3M2H	5L
30-70Pa	35,5-...	6,41	5H	5L
30-70Pa	39-...	7,17	5H	3L2M
30-70Pa	26,5-40	4,8	4LMH	6L
30-70Pa	33-50,5	6,04	6M	6L
30-70Pa	37,5-...	6,87	3M3H	6L
30-70Pa	40,5-...	7,42	M5H	6L



PACIFIC

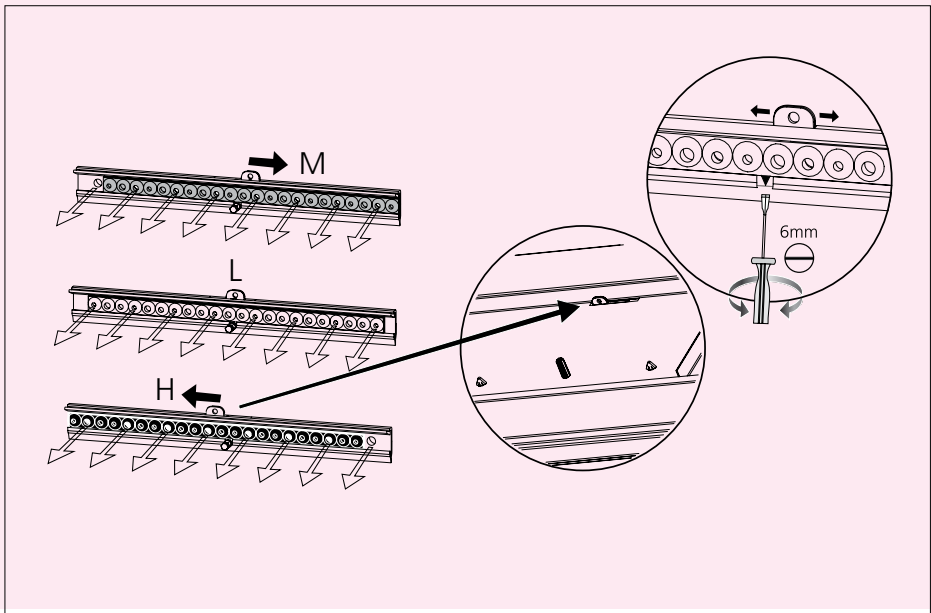
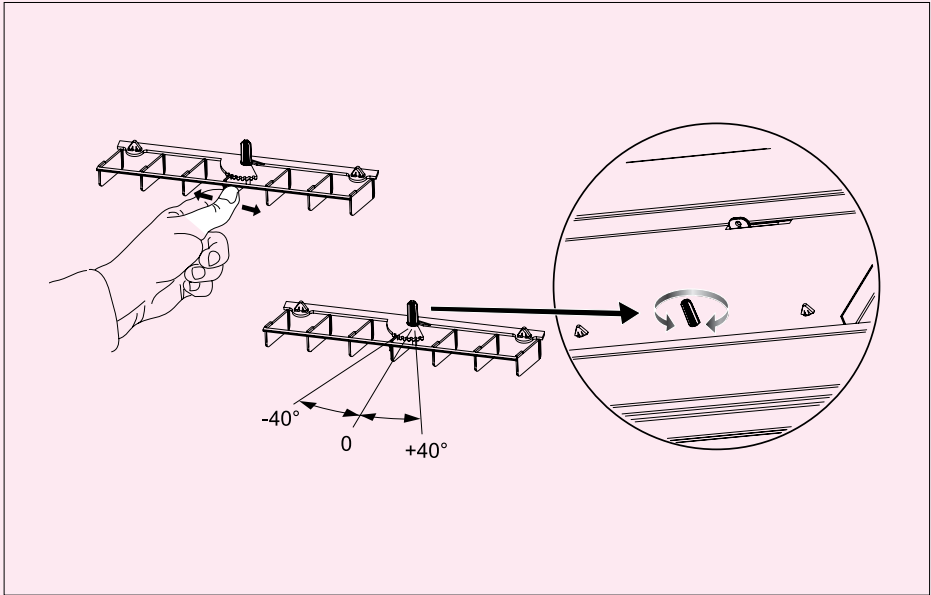



## PACIFIC

<b>PACIFIC Luftflödesvariant LF</b>		
Dysinställning		K-faktor/dyslist
Lågflöde	L	0,104
Medelflöde	M	0,168
Högflöde	H	0,224

<b>Antal dyslister</b>		
Storlek	Sida 2	Sida 4
1100	4	4
1600	6	6
2200	8	8
2700	10	10

<b>PACIFIC Luftflödesvariant MF</b>		
Dysinställning		K-faktor/dyslist
Lågflöde	L	0,152
Medelflöde	M	0,256
Högflöde	H	0,328

<b>PACIFIC Luftflödesvariant HF</b>		
Dysinställning		K-faktor/dyslist
Lågflöde	L	0,152
Medelflöde	M	0,296
Högflöde	H	0,392

Exempel för MF: Pacific 1792-1600 MF, Dysinställning L2M3H/3LM2H

Total K-faktor =  $0,152 + 2 \times 0,256 + 3 \times 0,328 + 3 \times 0,152 + 0,256 + 2 \times 0,328 = 3,016$



## PARAGON / PARAGON WALL

1.

Room 203  
PARAGON 1300  
22 l/s

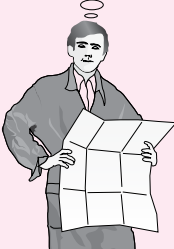

2. PARAGON 1300

Model	Supply	Return	Net	Max. diff. temp.
1300	16,4	28,4	1,5	2,1
1300	16,4	28,4	1,2	2,44
1300	16,4	28,4	1,0	2,88
1300	16,4	28,4	0,75	3,84
1300	16,4	28,4	0,5	5,76
1300	16,4	28,4	0,25	11,52
1300	16,4	28,4	0,1	36,0
1300	16,4	28,4	0,05	144,0

$$q = 16,4 - 28,4 \text{ (l/s)}$$

$$k = 2,32$$

$$q = L/L$$

$$q = k \cdot \sqrt{p_i} \text{ [l/s]}$$

$$p_i = (q/k)^2 \text{ [Pa]}$$

3.

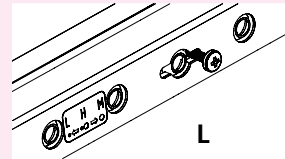
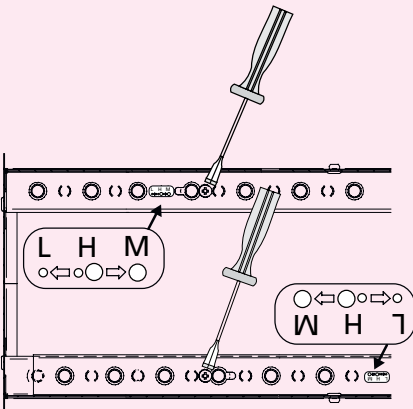
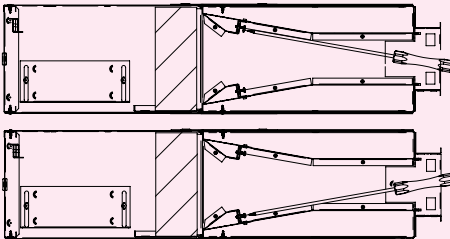

L

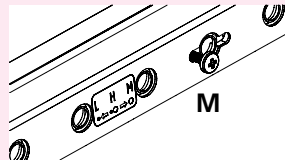

M

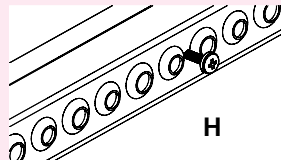

H

## PARAGON / PARAGON WALL

Storlek (mm)	Dystryck (Pa)	Luftflöde (l/s)	$K_{pl}$	Dysinställning
900	50 - 200 Pa	10,6 - 21,2	1,5	L / L
900	50 - 200 Pa	12 - 24	1,7	L / M
900	50 - 200 Pa	13,4 - 26,7	1,89	M / M
900	50 - 200 Pa	16,8 - 33,5	2,37	L / H
900	50 - 200 Pa	18,2 - 36,3	2,57	M / H
900	50 - 200 Pa	22,9 - 45,8	3,24	H / H
1100	50 - 200 Pa	13,7 - 27,4	1,94	L / L
1100	50 - 200 Pa	15,5 - 31	2,19	L / M
1100	50 - 200 Pa	17,3 - 34,5	2,44	M / M
1100	50 - 200 Pa	21,7 - 43,4	3,07	L / H
1100	50 - 200 Pa	23,5 - 47	3,32	M / H
1100	50 - 200 Pa	29,6 - 59,3	4,19	H / H
1300	50 - 200 Pa	16,4 - 32,8	2,32	L / L
1300	50 - 200 Pa	18,5 - 37,1	2,62	L / M
1300	50 - 200 Pa	20,6 - 41,3	2,92	M / M
1300	50 - 200 Pa	25,9 - 51,8	3,66	L / H
1300	50 - 200 Pa	28 - 56	3,96	M / H
1300	50 - 200 Pa	35,4 - 70,7	5	H / H
1500	50 - 200 Pa	13,9 - 27,9	1,97	L / L
1500	50 - 200 Pa	18,8 - 37,6	2,66	L / M
1500	50 - 200 Pa	23,7 - 47,4	3,35	M / M
1500	50 - 200 Pa	25,1 - 50,2	3,55	L / H
1500	50 - 200 Pa	30 - 60	4,24	M / H
1500	50 - 200 Pa	36,2 - 72,4	5,12	H / H



## PARASOL 600

PARASOL 600 MF		
Dysinställning per sida	Dysstorlek	$k_{pl}$ per sida
L	Liten	0,253
M	Stor	0,440
H	Liten + stor	0,693
C	Helt stängd	0

PARASOL 600 MF	
Dysinställning <sup>*)</sup>	$k_{pl}$
LLLL	1,01
LLMM	1,39
MMMM	1,76
MMHH	2,27
HHHH	2,77

<sup>\*)</sup> Alla fyra sidor på enheten kan ställas in individuellt. Dysinställningens benämning följer ordningen enligt figur 1. Se figur 2 för exempel.

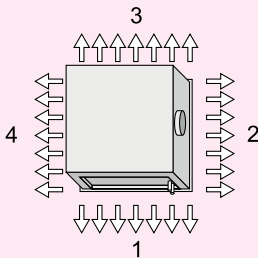

Figur 1. Toppy dysinställning enmodulsenhet PARASOL sida 1-4.

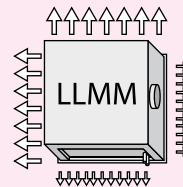

Figur 2. Exempel på dysinställning enmodulsenhet PARASOL - LLMM.



## PARASOL 1200

PARASOL 1200 LF			
Dysinställning per sida	Sida	Dysstorlek	$k_{pl}$ per sida
L	Kortsida	Liten	0,124
L	Långsida	Liten	0,328
M	Kortsida	Stor	0,176
M	Långsida	Stor	0,464
H	Kortsida	Liten + stor	0,3
H	Långsida	Liten + stor	0,792
C	Kortsida	Helt stängd	0
C	Långsida	Helt stängd	0

PARASOL 1200 LF	
Dysinställning <sup>*)</sup>	$k_{pl}$
LLLL	0,9
LLMM	1,09
MMMM	1,28
MMHH	1,73
HHHH	2,18

<sup>\*)</sup> Alla fyra sidor på enheten kan ställas in individuellt. Dysinställningens benämning följer ordningen enligt figur 3. Se figur 4 för exempel.

PARASOL 1200 MF			
Dysinställning per sida	Sida	Dysstorlek	$k_{pl}$ per sida
L	Kortsida	Liten	0,176
L	Långsida	Liten	0,464
M	Kortsida	Stor	0,253
M	Långsida	Stor	0,667
H	Kortsida	Liten + stor	0,429
H	Långsida	Liten + stor	1,131
C	Kortsida	Helt stängd	0
C	Långsida	Helt stängd	0

PARASOL 1200 MF	
Dysinställning <sup>*)</sup>	$k_{pl}$
LLLL	1,28
LLMM	1,56
MMMM	1,84
MMHH	2,48
HHHH	3,12

<sup>\*)</sup> Alla fyra sidor på enheten kan ställas in individuellt. Dysinställningens benämning följer ordningen enligt figur 3. Se figur 4 för exempel.

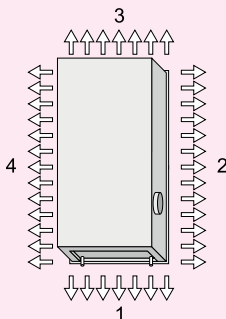

Figur 3. Toppvy dysinställning tvåmodulsenhet PARASOL sida 1-4.

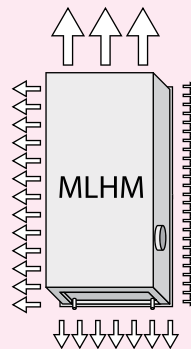

Figur 4. Exempel på dysinställning PARASOL tvåmodulsenhet - MLHM.



## PARASOL 1200

PARASOL 1200 HF			
Dysinställning per sida	Sida	Dysstorlek	$k_{pl}$ per sida
L	Kortsida	Liten	0,253
L	Långsida	Liten	0,667
M	Kortsida	Stor	0,44
M	Långsida	Stor	1,16
H	Kortsida	Liten + stor	0,693
H	Långsida	Liten + stor	1,827
C	Kortsida	Helt stängd	0
C	Långsida	Helt stängd	0

PARASOL 1200 HF	
Dysinställning **)	$k_{pl}$
LLLL	1,84
LLMM	2,52
MMMM	3,2
MMHH	4,12
HHHH	5,04

\*\*\*) Alla fyra sidor på enheten kan ställas in individuellt. Dysinställningens benämning följer ordningen enligt figur 5. Se figur 6 för exempel.

PARASOL 1200 PF			
Dysinställning per sida	Sida	Dysstorlek	$k_{pl}$ per sida
L	Kortsida	Liten	0,842
L	Långsida	Liten	2,221
M	Kortsida	Stor	0,991
M	Långsida	Stor	2,612
H	Kortsida	Liten + stor	1,211
H	Långsida	Liten + stor	3,192
C*)	Kortsida	Stängd	0,556
C*)	Långsida	Stängd	1,467

PARASOL 1200 PF	
Dysinställning ***)	$k_{pl}$
LLLL	6,126
LLMM	6,666
MMMM	7,206
MMHH	8,006
HHHH	8,806

\*) Parasol PF med dysa C är inte helt stängd.

\*\*\*) Alla fyra sidor på enheten kan ställas in individuellt. Dysinställningens benämning följer ordningen enligt figur 5. Se figur 7 för exempel.



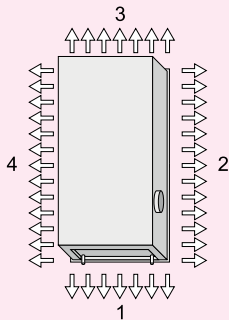

Figur 5. Toppvy dysinställning tvåmodulsenhet PARASOL sida 1-4.

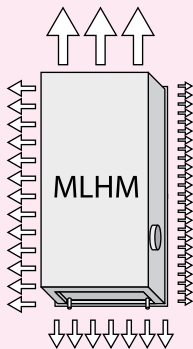

Figur 6. Exempel på dysinställning tvåmodulsenhet PARASOL - MLHM.

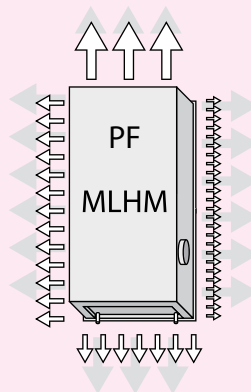

Figur 7. Exempel på dysinställning tvåmodulsenhet PARASOL PF - MLHM.



## PARASOL EX 690

PARASOL EX 690 MF		
Dysinställning per sida	Dysstorlek	$k_{pl}$ per sida
L	Liten	0,253
M	Stor	0,44
H	Liten + stor	0,693
C	Helt stängd	0

PARASOL EX 690 MF	
Dysinställning *)	$k_{pl}$
LLLL	1,01
LLMM	1,39
MMMM	1,76
MMHH	2,27
HHHH	2,77

\*) Alla fyra sidor på enheten kan ställas in individuellt. Dysinställningens benämning följer ordningen enligt figur 8. Se figur 9 för exempel.

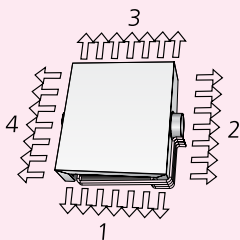

Figur 8. Toppvy dysinställning Parasol EX enmodulsenhet, sida 1-4.

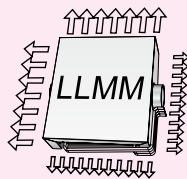

Figur 9. Exempel på dysinställning Parasol EX enmodulsenhet - LLMM.



## PARASOL EX 1290

PARASOL EX 1290 MF			
Dysinställning per sida	Sida	Dysstorlek	$k_{pl}$ per sida
L	Kortsida	Liten	0,176
L	Långsida	Liten	0,464
M	Kortsida	Stor	0,253
M	Långsida	Stor	0,667
H	Kortsida	Liten + stor	0,429
H	Långsida	Liten + stor	1,131
C	Kortsida	Helt stängd	0
C	Långsida	Helt stängd	0

PARASOL EX 1290 MF	
Dysinställning *)	$k_{pl}$
LLLL	1,28
LLMM	1,56
MMMM	1,84
MMHH	2,48
HHHH	3,12

\*) Alla fyra sidor på enheten kan ställas in individuellt. Dysinställningens benämning följer ordningen enligt figur 10. Se figur 11 för exempel.

PARASOL EX 1290 HF			
Dysinställning per sida	Sida	Dysstorlek	$k_{pl}$ per sida
L	Kortsida	Liten	0,253
L	Långsida	Liten	0,667
M	Kortsida	Stor	0,44
M	Långsida	Stor	1,16
H	Kortsida	Liten + stor	0,693
H	Långsida	Liten + stor	1,827
C	Kortsida	Helt stängd	0
C	Långsida	Helt stängd	0

PARASOL EX 1290 HF	
Dysinställning *)	$k_{pl}$
LLLL	1,84
LLMM	2,52
MMMM	3,2
MMHH	4,12
HHHH	5,04

\*) Alla fyra sidor på enheten kan ställas in individuellt. Dysinställningens benämning följer ordningen enligt figur 10. Se figur 11 för exempel.

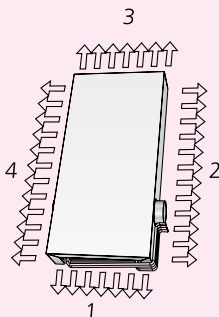

Figur 10. Toppvy dysinställning Parasol EX tvåmodulsenhet sida 1-4.

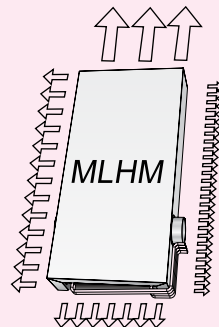

Figur 11. Exempel på dysinställning Parasol EX tvåmodulsenhet - MLHM.



## ADAPT Parasol

K-faktor sida 1 + 3 = k1  
= frånvaroflöde

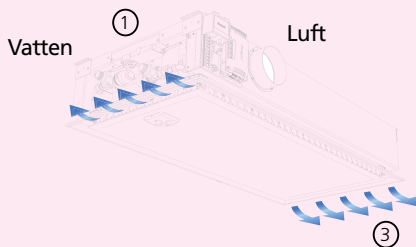

K-faktor sida 1 + 2 + 3 + 4 = k2  
= max. närvaroflöde

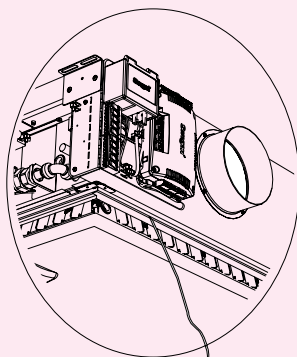
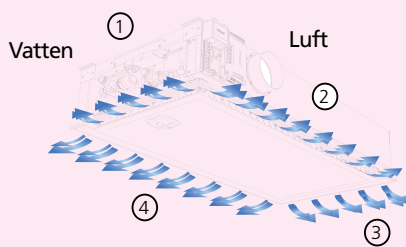

Pressure constant  $k_p$ : 0,50 / 3,66

$$k1 / k2$$
$$K_p = 0.50 / 3.66$$

*OBS! Vid ändring mellan max- och minflöde kommer dystrycket att ändras något.*



## ADAPT Parasol 600

ADAPT Parasol 600			
Dysinställning per sida	Sida	$k_{pl}$ per sida	
		*	**
L	1&3	0,253	0,253
L	2&4	0	0,253
M	1&3	0,44	0,44
M	2&4	0	0,44
H	1&3	0,693	0,693
H	2&4	0	0,693

\*) = k-faktor för injustering av frånvaroflöde.

\*\*) = k-faktor för injustering av max närvaroflöde

ADAPT Parasol 600		
Exempel Dysinställning ***)	$k_{pl}$	
	k1	k2
LLLL	0,51	1,01
LHLH	0,51	1,89
MMMM	0,88	1,76
HHHH	1,39	2,77

\*\*\*) Alla fyra sidor på enheten kan ställas in individuellt. Dysinställningens benämning följer ordningen enligt figur 12. Se figur 13 för exempel.

k1 = Frånvaroflöde

k2 = Max. närvaroflöde

## ADAPT Parasol 600 PF

ADAPT Parasol 600 PF			
Dysinställning per sida	Sida	$k_{pl}$ per sida	
		*	**
L	1&3	0,28	0,82
L	2&4	0	0,745
M	1&3	0,435	0,98
M	2&4	0	0,905
H	1&3	0,685	1,23
H	2&4	0	1,15

\*) = k-faktor för injustering av frånvaroflöde.

\*\*) = k-faktor för injustering av max närvaroflöde

ADAPT Parasol 600 PF		
Exempel Dysinställning ***)	$k_{pl}$	
	k1	k2
LLLL	0,56	3,13
LHLH	0,56	3,95
MMMM	0,87	3,77
HHHH	1,37	4,76

\*\*\*) Alla fyra sidor på enheten kan ställas in individuellt. Dysinställningens benämning följer ordningen enligt figur 12. Se figur 13 för exempel.

k1 = Frånvaroflöde

k2 = Max. närvaroflöde

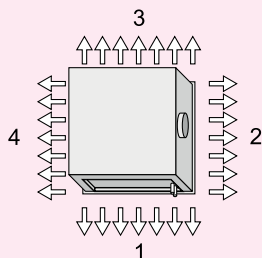

Figur 12. Toppvy dysinställning ADAPT Parasol enmodulsenhet sida 1-4.

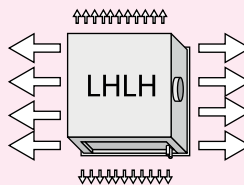

Figur 13. Exempel på dysinställning ADAPT Parasol enmodulsenhet - LHLH.



## ADAPT Parasol 1200

ADAPT Parasol 1200			
Dysinställning per sida	Sida	$k_{pl}$ per sida	
		*	**
L	1&3	0,253	0,253
L	2&4	0	0,665
M	1&3	0,44	0,44
M	2&4	0	1,16
H	1&3	0,693	0,693
H	2&4	0	1,825

\*) = k-faktor för injustering av frånvaroflöde.

\*\*) = k-faktor för injustering av max närvaroflöde

ADAPT Parasol 1200		
Exempel Dysinställning ***)	$k_{pl}$	
	k1	k2
LLLL	0,51	1,84
LHLH	0,51	4,16
MMMM	0,88	3,20
HHHH	1,39	5,04

\*\*\*) Alla fyra sidor på enheten kan ställas in individuellt. Dysinställningens benämning följer ordningen enligt figur 14. Se figur 15 för exempel.

k1 = Frånvaroflöde

k2 = Max. närvaroflöde

## ADAPT Parasol 1200 PF

ADAPT Parasol 1200 PF			
Dysinställning per sida	Sida	$k_{pl}$ per sida	
		*	**
L	1&3	0,28	0,82
L	2&4	0	2,05
M	1&3	0,435	0,98
M	2&4	0	2,43
H	1&3	0,685	1,23
H	2&4	0	2,98

\*) = k-faktor för injustering av frånvaroflöde.

\*\*) = k-faktor för injustering av max närvaroflöde

ADAPT Parasol 1200 PF		
Exempel Dysinställning ***)	$k_{pl}$	
	k1	k2
LLLL	0,56	5,74
LHLH	0,56	7,61
MMMM	0,87	6,82
HHHH	1,37	8,42

\*\*\*) Alla fyra sidor på enheten kan ställas in individuellt. Dysinställningens benämning följer ordningen enligt figur 14. Se figur 15 för exempel.

k1 = Frånvaroflöde

k2 = Max. närvaroflöde

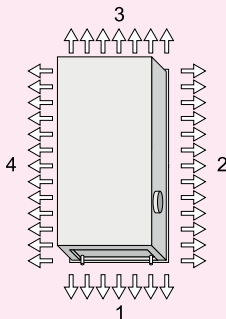

Figur 14. Toppvy dysinställning ADAPT Parasol tvåmodulsenhet sida 1-4.

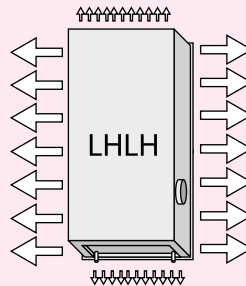

Figur 15. Exempel på dysinställning ADAPT Parasol tvåmodulsenhet - LHLH.



## ADAPT Parasol EX

K-faktor sida 1 + 3 = k1  
= frånvaroflöde

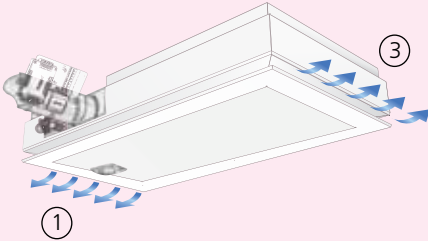

K-faktor sida 1 + 2 + 3 + 4 = k2 =  
max. närvaroflöde

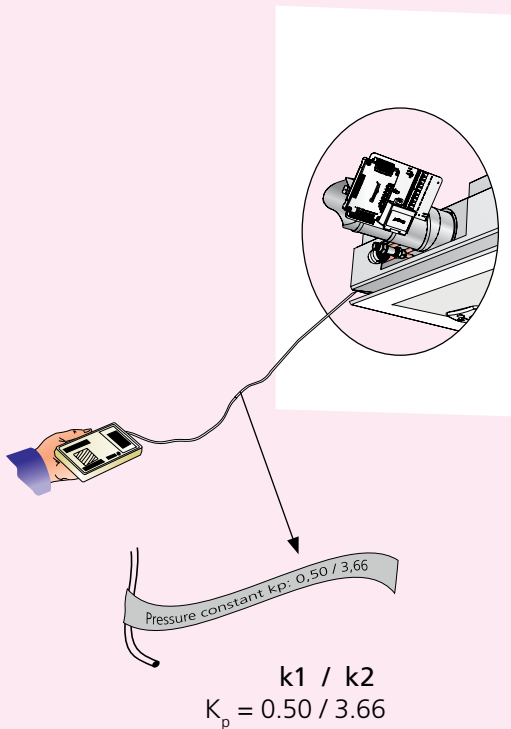
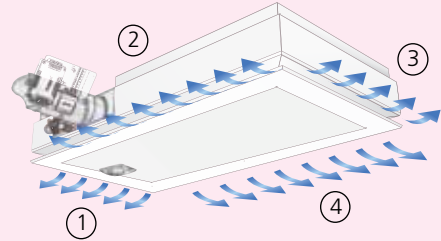

OBS! Vid ändring mellan max- och minflöde kommer dystrycket att ändras något.



## ADAPT Parasol EX 690

ADAPT Parasol 690 EX			
Dysinställning per sida	Sida	$k_{pl}$ per sida	
		*	**
L	1&3	0,253	0,253
L	2&4	0	0,253
M	1&3	0,44	0,44
M	2&4	0	0,44
H	1&3	0,693	0,693
H	2&4	0	0,693

\*) = k-faktor för injustering av frånvaroflöde.

\*\*) = k-faktor för injustering av max närvaroflöde

ADAPT Parasol 690 EX		
Exempel Dysinställning ***)	$k_{pl}$	
	k1	k2
LLLL	0,51	1,01
LHLH	0,51	1,89
MMMM	0,88	1,76
HHHH	1,39	2,77

\*\*\*) Alla fyra sidor på enheten kan ställas in individuellt. Dysinställningens benämning följer ordningen enligt figur 16. Se figur 17 för exempel.

k1 = Frånvaroflöde

k2 = Max. närvaroflöde

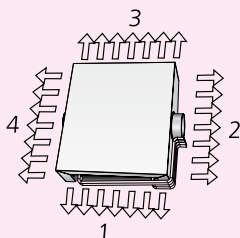

Figur 16. Toppvy dysinställning ADAPT Parasol EX enmodulsenhet, sida 1-4.

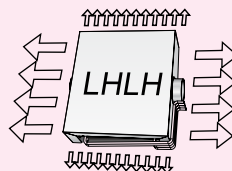

Figur 17. Exempel på dysinställning ADAPT Parasol EX enmodulsenhet - LHLH.





## ADAPT Parasol EX 1290

ADAPT Parasol EX 1290			
Dysinställning per sida	Sida	k <sub>pl</sub> per sida	
		*	**
L	1&3	0,253	0,253
L	2&4	0	0,665
M	1&3	0,44	0,44
M	2&4	0	1,16
H	1&3	0,693	0,693
H	2&4	0	1,825

\*) = k-faktor för injustering av frånvaroflöde.

\*\*) = k-faktor för injustering av max närvaroflöde

ADAPT Parasol EX 1290		
Exempel Dysinställning ***)	k <sub>pl</sub>	
	k1	k2
LLLL	0,51	1,84
LHLH	0,51	4,16
MMMM	0,88	3,20
HHHH	1,39	5,04

\*\*\*) Alla fyra sidor på enheten kan ställas in individuellt. Dysinställningens benämning följer ordningen enligt figur 18. Se figur 19 för exempel.

k1 = Frånvaroflöde

k2 = Max. närvaroflöde

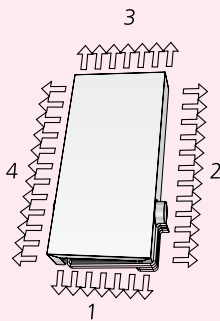

Figur 18. Toppvy dysinställning ADAPT Parasol EX tvåmodulsenhet sida 1-4.

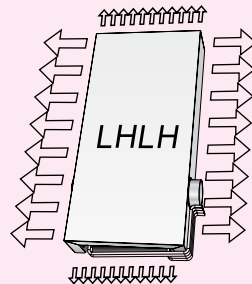

Figur 19. Exempel på dysinställning ADAPT Parasol EX tvåmodulsenhet - LHLH.































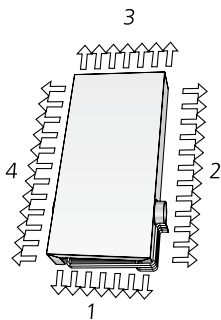

Figure 7. Top view nozzle setting, double-module unit sides 1-4.

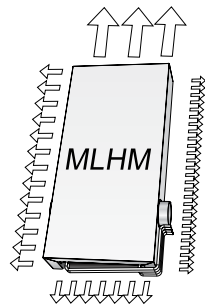

Figure 8. Example of nozzle setting for a double-module unit - MLHM.



[www.swegon.com](http://www.swegon.com)

GB-Commissioning Guide 2010-07-07

