

Draw No. AA/F11261

Rev. A

DIMENSIONS IN MILLIMETRES

DO NOT SCALE



**actionair**  
 © RUSKIN AIR MANAGEMENT LIMITED  
 South Street, Whitstable  
 Kent CT5 3DU  
 Telephone: 01227 276100  
 Facsimile: 01227 264262  
 www.actionair.co.uk

**NOTES:**

ST/STL BEARINGS TO BE USED.

THIS DRAWING HAS BEEN PREPARED ON INFORMATION GIVEN TO RUSKIN AIR MANAGEMENT LTD. THIS METHOD WOULD BE SUBJECT TO THE SCRUTINY AND APPROVAL FROM THE RELEVANT DISTRICT SURVEYOR / LOCAL AUTHORITY PRIOR TO APPROVING AND ORDERING THE PRODUCT DETAILED IN THIS DRAWING.

THIS DRAWING IS NOT INTENDED TO ENDORSE THE ARRANGEMENT AS BEING SUITABLE FOR IT'S INTENDED APPLICATION.

THE INFORMATION SHOWN IS SUBJECT TO CHANGE WITHOUT NOTICE DUE TO CONTINUING RESEARCH AND DEVELOPMENT.

Rev	Change	Initials	Dates
A	MADE GENERIC	J.M.	20/06/14
Drawn by		J.M.	21/03/14
Checked by		L.M.	20/06/14
Approved by		p.p. G.B.	20/06/14
Customer		GARDNER & CO	
Project		UKPN	

Description  
 ES50R WITH JACKSHAFT ASSEMBLY

Drawing No. AA/F11261  
 Revision A

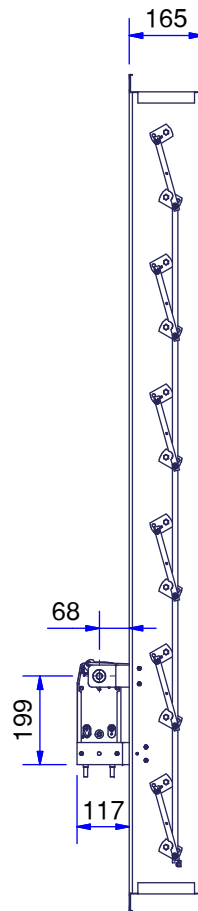
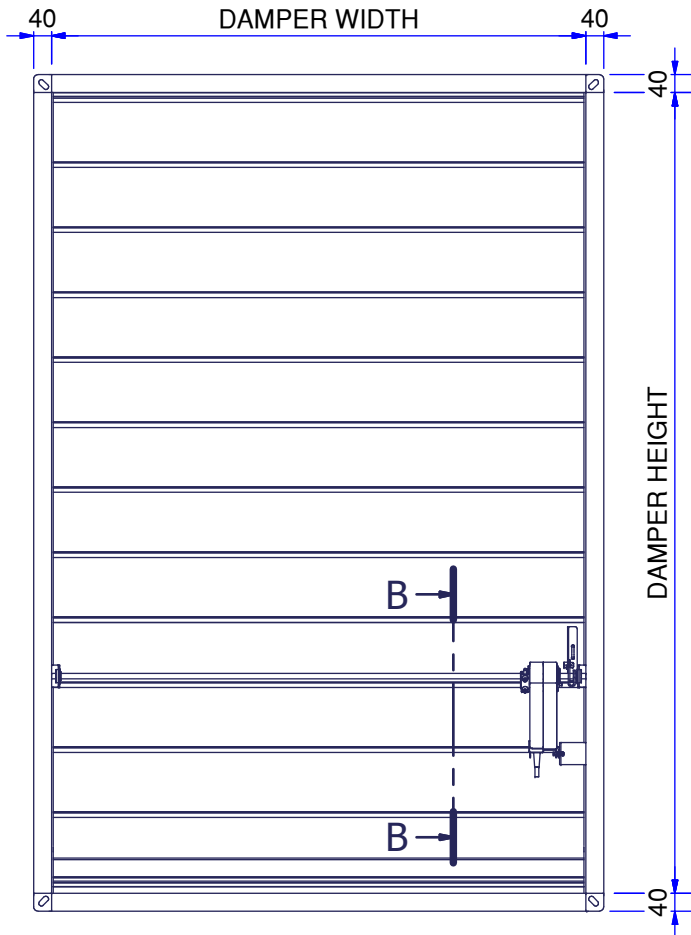
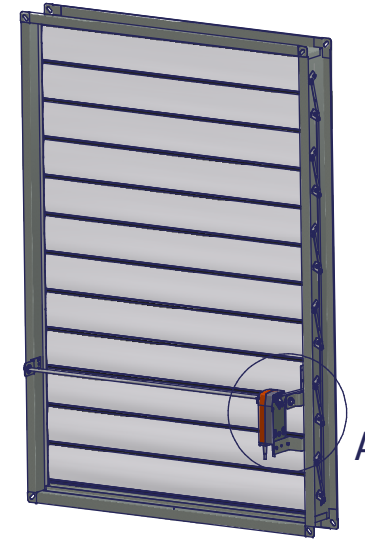
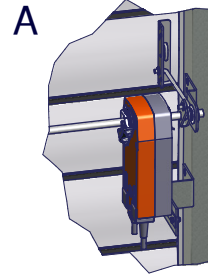

**B-B (ACTUATOR REMOVED)**

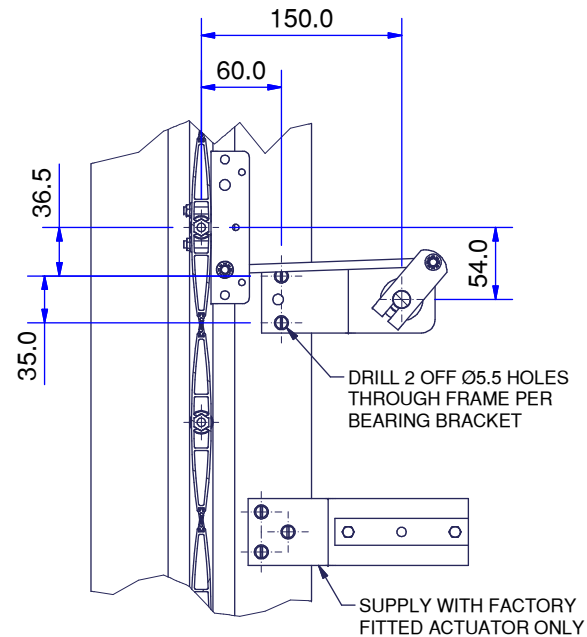

This drawing is confidential communication and is the property of Ruskin Air Management Limited and is returnable on request. It is not to be copied, loaned or communicated without the consent of Ruskin Air Management Limited. This drawing should be considered uncontrolled if it is a printed copy, or has been transmitted outside of Ruskin Air Management Limited, electronically. The live version is the electronic copy held at Ruskin Air Management Ltd. Please confirm the drawing issue before placing any orders which refer to this drawing. The Information Shown Is Subject To Change Without Notice Due To Continuing Research And Development.