

TRITON KSUE

Slave unit or stand-alone unit for control and monitoring of fire dampers



QUICK FACTS

- Stand-alone or slave unit to SUSA or KSUA
- 16 fire dampers in 8 damper groups
- 4 analog smoke detector inputs
- 2 alarm relays (A & B)
- Manages 1 air handling unit (fan)
- Input for central fire alarm or night closing

KSUE

CONTENTS

Description.....	2
General system overview	3
Accessories	3
Terminals.....	4
Damper Wiring	5
Wiring in stand-alone mode.....	6
Wiring in network mode.....	8
Specification.....	9
Terminology	10
Operating instructions/troubleshooting	11

DESCRIPTION

The KSUE is a control and monitoring unit for fire protection in ventilation systems, intended to control fire dampers and an air handling unit (fan). The unit regularly monitors the damper's end positions.

The unit can be used as a fully **stand-alone** unit or as a **slave unit** in networks with the SUSA or KSUA master unit.

- 16 fire dampers in 8 damper groups
- 4 smoke detector loops (max 5 per loop)
- Handles 1 air handling unit (fan)
- Damper test interval of 48 hours, 7 days or 30 days
- Sequential damper test
- Input for an external fire alarm (EXT).
- Input for night mode or damper test
- A and B alarm relay (fire/sum alarm)
- Integrated transformer 230/24 VAC

Important.

Safety may be affected if the unit is used other than as specified in the manual.

GENERAL SYSTEM OVERVIEW

The following diagram is a typical example of network mode between the SUSA master unit and slave units. Follow the instructions to install the KSUE as a stand-alone unit or as a slave unit for the SUSA or KSUA.

You can also visit our website oncontrol.se to use our product selection program.

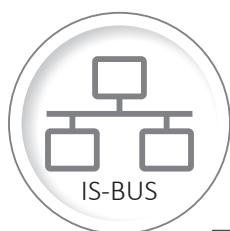

- Max length of IS-BUS 1200 m
- Daisy chain with max branch length 20 m
- Max 32 slave units

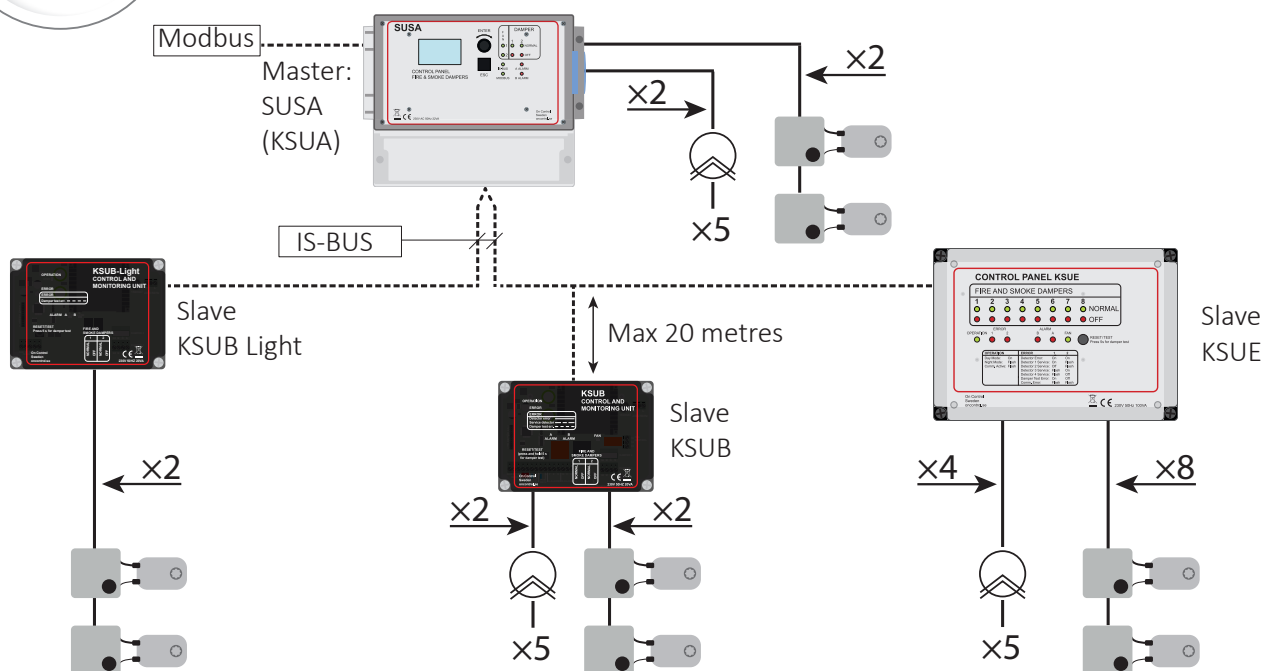

UNIT	FIRE DAMPER	SMOKE DETECTOR
SUSA	4 (2X2)	10 (2X5)
KSUE	16 (8X2)	20 (4X5)
KSUB	4 (2X2)	10 (2X5)
KSUB Light	4 (2X2)	0

ACCESSORIES

KBOX

The KBOX connection box makes it much easier to connect the actuators to the control unit. There are labelled terminals and an integrated motor test button.

It is also easy to connect two actuators to a damper group (parallel connection).

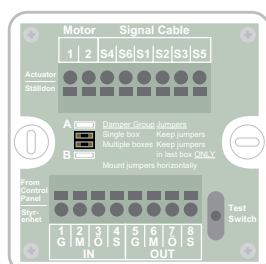

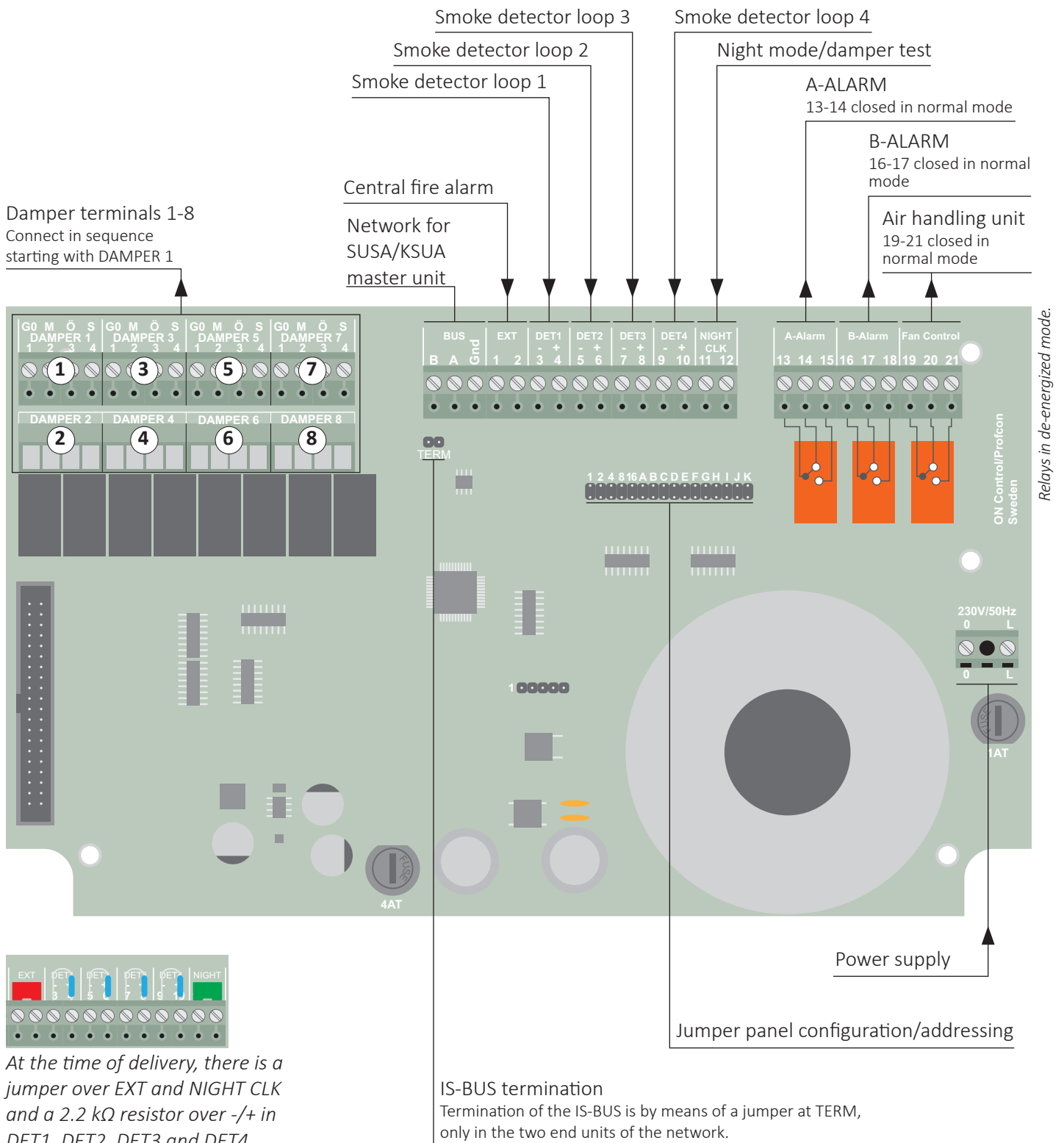

At the time of delivery, there is a jumper over EXT and NIGHT CLK and a 2.2 kΩ resistor over -/+ in DET1, DET2, DET3 and DET4

Connection

To install the unit in stand-alone or network mode (slave unit for the SUSA/KSUA), connect it as shown in the tables below:

- Connections in stand-alone mode on page 6, 7
- Connections in network mode on page 8

Cable recommendation

- The smoke detectors are connected using telephone type twisted pair cables with no particular requirements in terms of area.
- A damper motor can be connected using EKKX 1x4x0.5 for example.
 - One damper per damper group, max 100 metres
 - Two dampers per damper group, max 50 metres
- The IS-BUS network can be connected using FKAR-PG 2x0.5.

DAMPER WIRING

Wiring - PARALLEL

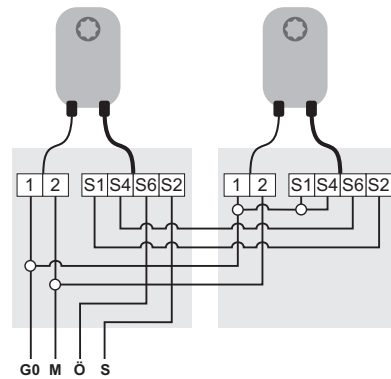

IMPORTANT!
Connect in sequence starting with DAMPER 1

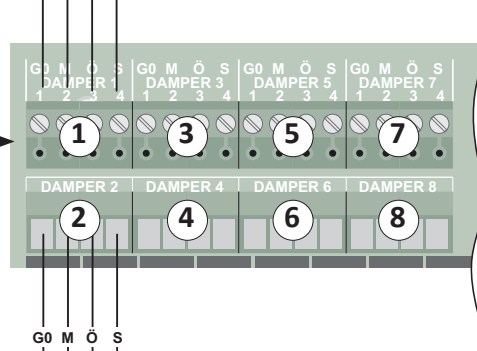

Wiring - INDIVIDUAL

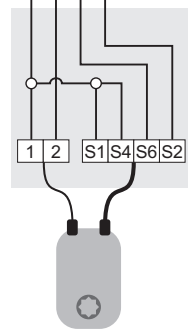

Safety actuator 24 VAC (spring return)

Usual cable colours

1 - BLACK
2 - RED
S1 - VIOLET
S2 - RED
S3 - WHITE
S4 - ORANGE
S5 - PINK
S6 - GREY

Not used

Not used

Connecting fire dampers

- Fire dampers are connected as shown above with a maximum of two dampers per damper group (DAMPER 1 to 8).
- A bypass/pressure relief damper type with spring return to the open position can only be handled if the KSUE is used as a slave unit and the damper type is connected as a fire damper. The damper types must not be mixed within the same damper group.

IMPORTANT!
In stand-alone mode, the number of damper groups (1 to 8) must be configured and connected in sequence starting with DAMPER1.

TIP!
The KBOX accessory has a PCB with labelled terminals and is recommended in order to simplify the connection process.



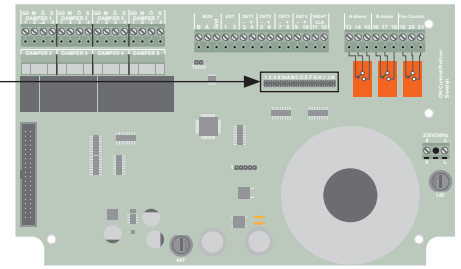

STAND-ALONE MODE

IMPORTANT!
 Page 6-7 only describes installation in stand-alone mode. This means that jumper A must be on.



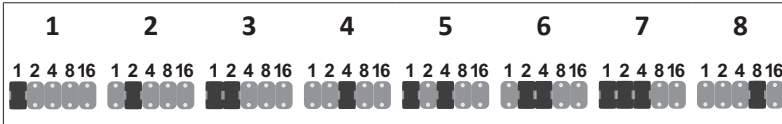

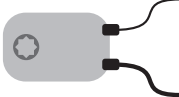

Jumper for the number of damper groups



CONTROL OF EXTERNAL UNIT	TERMINAL	NAME	DESCRIPTION	JUMPER	JUMPER POSITION	
					FUNCTION WITH JUMPER ON	FUNCTION WITH JUMPER OFF
Fire damper 	G0, M, Ö, S	DAMPER 1, DAMPER 2, DAMPER 3, DAMPER 4, DAMPER 5, DAMPER 6, DAMPER 7, DAMPER 8,	24 V fire damper with spring return, installed as described in Damper connections on page 5. Max 16 dampers divided between 8 damper groups (max 2 per DAMPER). Must be installed in sequence from 1 to 8. Damper test interval starts after 10 hours. This happens after each restart. Operation max 90 VA / 3 min / Standby max 35 VA / 48 h. The number of active damper groups (DAMPER) is configured according to the table above.	1-8	Configure the number of active damper groups (DAMPER) 1 to 8. See the table above.	
				C	Sequential damper test	Simultaneous damper test
				H	Damper test interval: 48 hours	No automatic test interval <i>No jumper on H or I</i>
				I	Damper test interval: 1 week	
				H+I	Damper test interval: 30 days	
Air handling unit 	19, 20, 21	FAN CONTROL	Terminals 19-21 are closed in normal mode and change with A alarm and damper test depending on the jumper configuration. The relay is a voltage-free changeover contact, max 5 A/250 VAC. There are selectable delays for the damper test to allow the duct pressure to reduce or the electric heater to cool down before the damper test takes place.	D	Fan does NOT stop in “night mode”	Fan stops in “night mode”
				E	NO delay when fan stopped	Fan stopped in the damper test
				F	Fan stopped 5 min before damper test	<i>Not used (N/A)</i>
				G	Fan NOT stopped in the damper test	Fan stopped 30 s before damper test starts

WIRING IN STAND-ALONE MODE

INPUTS	TERMINAL	NAME	DESCRIPTION	JUMPER	FUNCTION WITH JUMPER ON	FUNCTION WITH JUMPER OFF
Smoke detector 	3(-), 4(+)	DET 1	Replace existing resistor with smoke detector of type UG3-0 or similar. Max 5 in a loop per input. Terminate the last one with 2.2 kΩ	B	4 detector zones <ul style="list-style-type: none"> ▪ DET 1 affects DAMPER 1+2 ▪ DET 2 affects DAMPER 3+4 ▪ DET 3 affects DAMPER 5+6 ▪ DET 4 affects DAMPER 7+8 	1 detector zone
	5(-), 6(+)	DET 2				
	7(-), 8(+)	DET 3				
	9(-), 10(+)	DET 4				
Fire alarm 	1-2	EXT	Normally closed. Activated by voltage-free external break. Affects all function groups.	J	Automatic reset of fire alarm if EXT is closed	Manual reset of fire alarm
Night mode/damper test 	11-12	NIGHT/CLK	Normally closed. Activated by voltage-free external break. Affects all damper groups. The damper test can take place if in night mode.	K	Night mode keeps all dampers closed while break continues.	CLK (clock) starts the damper test with external break

OUTPUTS (ALARM)	TERMINAL	NAME	DESCRIPTION
Fire alarm 	13, 14, 15	A ALARM	Terminals 13-14 are closed in normal mode and change with fire alarm from EXT or DET. The relay is a voltage-free changeover contact, max 5 A/250 VAC.
Sum alarm 	16, 17, 18	B ALARM	Terminals 16-17 are closed in normal mode and change with <ul style="list-style-type: none"> ▪ detector fault/service ▪ damper fault and ▪ fire alarm. The relay is a voltage-free changeover contact, max 5 A/250 VAC.

POWER SUPPLY	TERMINAL	NAME	DESCRIPTION
230 VAC 50 Hz	0, L	230 V/50 Hz	Connected with permanent cabling and isolating switch.

**IMPORTANT!**

Do not forget to perform a manual function test by pressing the TEST button after you finish configuration/connection.

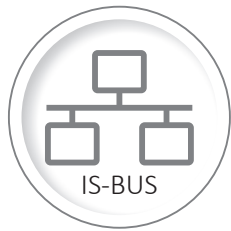

NETWORK MODE

IMPORTANT!
 This page describes installation of the KSUE in **network mode** to the SUSA or KSUA master unit, and is not applicable to stand-alone mode. This means that jumper A must be off.

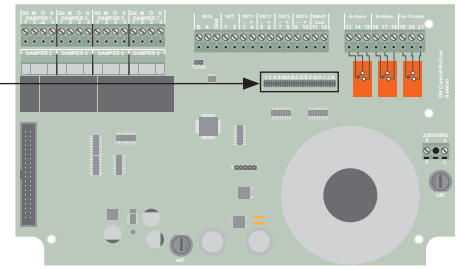

Addressing in the KSUE 0 to 31

0	1	2	3	4	5	6	7	8	9	10	11	12	13	14	15
1 2 4 8 16	1 2 4 8 16	1 2 4 8 16	1 2 4 8 16	1 2 4 8 16	1 2 4 8 16	1 2 4 8 16	1 2 4 8 16	1 2 4 8 16	1 2 4 8 16	1 2 4 8 16	1 2 4 8 16	1 2 4 8 16	1 2 4 8 16	1 2 4 8 16	1 2 4 8 16
16	17	18	19	20	21	22	23	24	25	26	27	28	29	30	31
1 2 4 8 16	1 2 4 8 16	1 2 4 8 16	1 2 4 8 16	1 2 4 8 16	1 2 4 8 16	1 2 4 8 16	1 2 4 8 16	1 2 4 8 16	1 2 4 8 16	1 2 4 8 16	1 2 4 8 16	1 2 4 8 16	1 2 4 8 16	1 2 4 8 16	1 2 4 8 16

Wiring

CONTROL OF EXTERNAL UNIT	TERMINAL	NAME	DESCRIPTION
Fire/evacuation damper 	G0, M, Ö, S	DAMPER 1, DAMPER 2, DAMPER 3, DAMPER 4, DAMPER 5, DAMPER 6, DAMPER 7, DAMPER 8	24 VAC fire or evacuation damper with spring return. Max 16 dampers divided between 8 damper groups with max 2 per group. Operation max 90 VA / 3 min / Standby max 35 VA / 48 h Installed as described in Inkoppling spjäll på sidan 5. Damper tests are performed by the master unit. The damper groups must be configured in the master unit.
Air handling unit 	19, 20, 21	FAN CONTROL	<ul style="list-style-type: none"> The slave unit with the lowest address echoes the function from master unit relay number 1 The next slave address echoes the function from relay number 2 in the master unit. The relay is a voltage-free changeover contact, max 5 A/250 VAC.

INPUTS	TERMINAL	NAME	DESCRIPTION
Smoke detector 	3(-), 4(+)	DET 1	Replace existing resistor with smoke detector of type UG3-0 or similar. Max 5 per input. Terminate the last one with 2.2 kΩ. The detector inputs must be configured from the master unit.
	5(-), 6(+)	DET 2	
	7(-), 8(+)	DET 3	
	9(-), 10(+)	DET 4	
Fire alarm 	1-2	EXT	Normally closed and activated by voltage-free external break. Affects the whole system. Detector group 1 must be activated in the master unit for the function to be available. Keep the resistor in the terminal.
Network 	Gnd, A, B	BUS	Network connection to the SUSA or KSUA master unit which must ONLY be connected to IS-BUS . Daisy chaining between units with Gnd to Gnd, A to A and B to B. Addressing in the KSUE is as shown in the table above. The unit can then be configured in the master unit. Termination of the IS-BUS is by means of a jumper at TERM, only in the two end units of the network.

POWER SUPPLY	TERMINAL	NAME	DESCRIPTION
230 VAC 50 Hz	0, L	230 V/50 Hz	Connected with permanent cabling and isolating switch.

SPECIFICATION

Installation

Intended to be attached to a wall indoors.

Power supply

230 VAC, 50 Hz, 110 VA. Fused with max 10 A / min 2 A.

The mains voltage may vary $\pm 10\%$.

Transient voltages up to overvoltage category II.

Protection class

IP65

Ambient temperature

Max +35 °C, min -5 °C

Altitude up to 2000 m

Max relative humidity 80% at temperatures up to 31 °C

Max relative humidity falls in a linear fashion to 50% at 40 °C

Weight

2.5 Kg

Outputs

- B alarm – potential-free changeover contact, max 5 A/250 V. Terminal numbers 16, 17, 18.
- A alarm – shared by all detectors and EXT. Potential-free changeover contact, max 5 A/250 V. Terminal numbers 13, 14, 15.
- Fan – potential-free changeover contact, max 5 A/250 V. Terminal numbers 19, 20, 21.
- Damper groups 1 to 8 (DAMPER)

Inputs

- IS network bus to SUSA or KSUA master unit.
- External fire alarm (EXT). Affects all damper groups.
- Night mode input (NIGHT) or damper test input (CLK)
- Detector 1. Terminals 3,4
- Detector 2. Terminals 5,6
- Detector 3. Terminals 7,8
- Detector 4. Terminals 9,10
- Input for 230 V/50 Hz

Fuses

There are two fuses on the motherboard. One protects the whole unit and is 1 AT 250 V (FS2). The other is 4 AT 250 V (FS3) and protects the damper motors.

The holders are the bayonet type. To remove the fuse, first press down and then turn a quarter turn anticlockwise.

Pollution degree

Pollution degree 2 is valid for the intended environment.

Isolating switch

The installation must have an isolating switch or circuit breaker.



It must be easy to access at a suitable location.

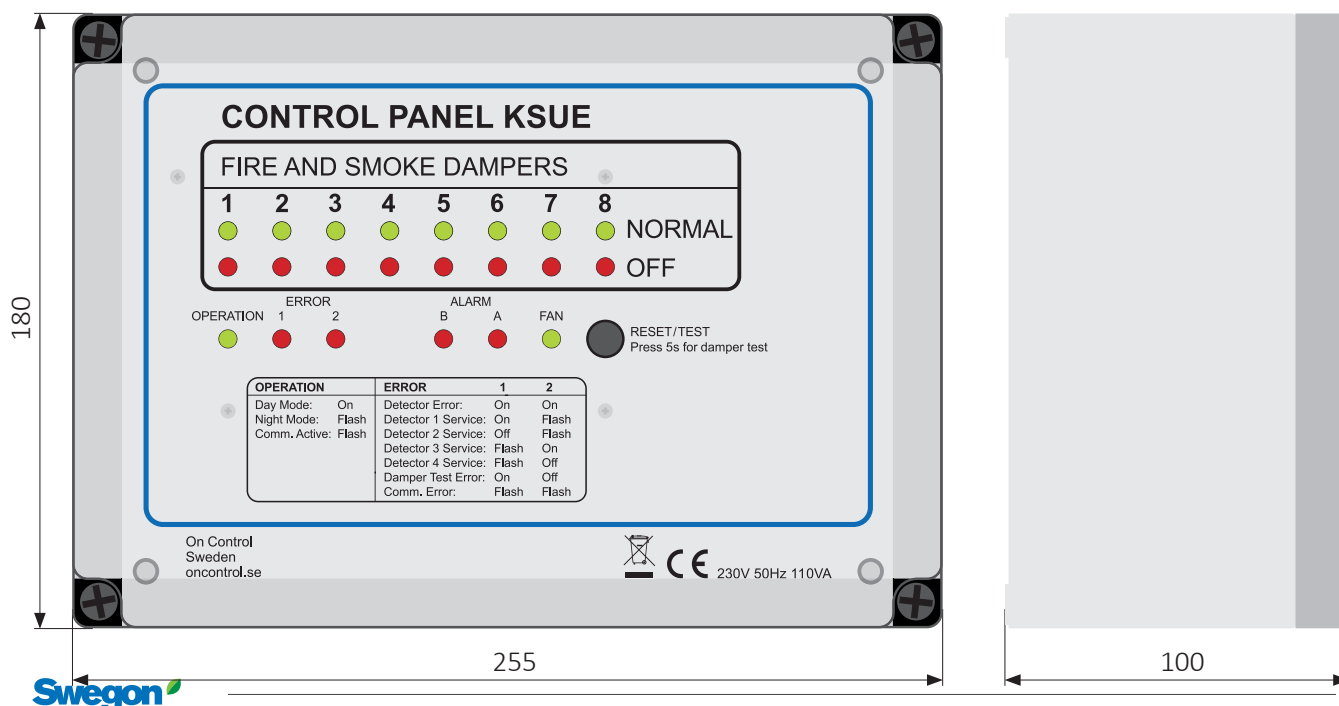



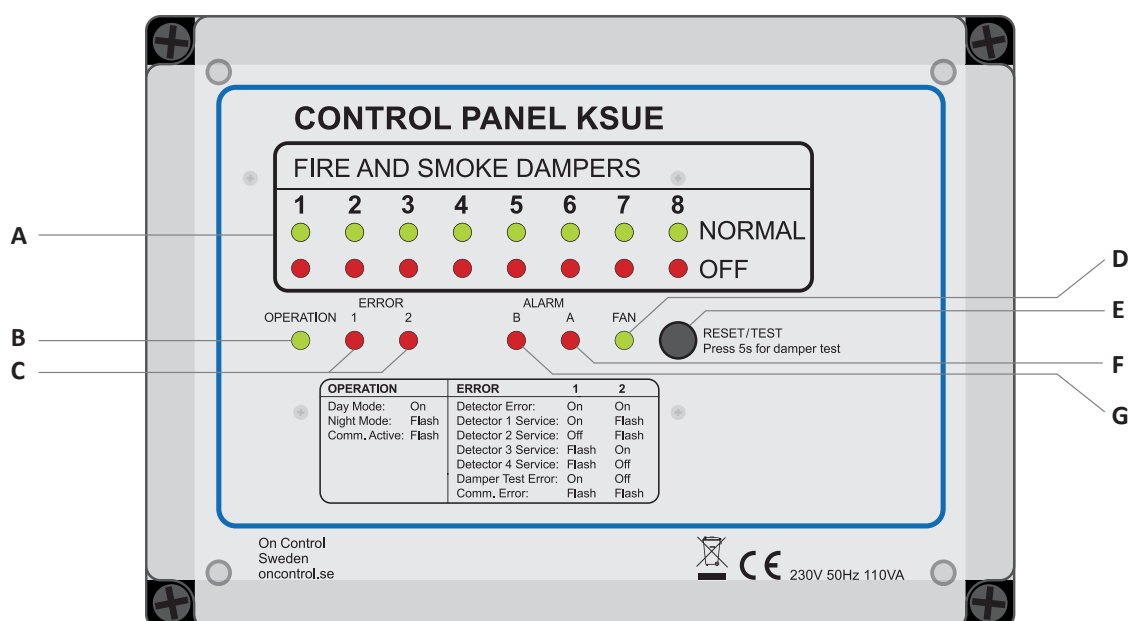









It must be labelled as the isolating device for the equipment.

Dimensions

Ventilation damper	A fire damper with a 24 VAC motor. It closes with spring force to the fail-safe position (closed).
Evacuation/ pressure relief/ bypass damper	A damper with a 24 VAC motor. It opens with spring force to the fail-safe position (open).
Normal mode	Ventilation dampers are open and evacuation dampers are closed.
Night mode	All damper types close. For example, used if the ventilation system is shut down to save energy. The fire damper is put in the fail-safe position and then opens when the NIGHT input closes again. Damper tests (if any) can take place at this time.
Stand-alone mode	The unit is not connected via the IS-BUS network to a master unit. It is instead completely stand-alone and alarms are indicated via LED and the voltage-free changeover relay. The jumper panel is used for configuration.
Network mode	The SUSA or KSUA master unit communicates all alarms, function tests, etc. between the slave units over the IS-bus. Max 32 slaves.
Parallel connection	This means two dampers connected to a single damper group (DAMPER). An individual damper error will affect the NORMAL/OFF indication for the damper group (in network mode this appears in the master unit).
Jumper panel	For installation in stand-alone mode, the jumper field is used to configure the unit. For installation in network mode, the jumper panel is used for slave unit addressing.



FUNCTION	DESCRIPTION
A DAMPER 1, DAMPER 2, DAMPER 3, DAMPER 4, DAMPER 5, DAMPER 6, DAMPER 7, DAMPER 8	<p>Indicates the end position of the fail-safe actuator for each of the damper groups DAMPER 1 to 8.</p> <ul style="list-style-type: none"> ▪ Green diode (NORMAL) indicates the position for normal mode <ul style="list-style-type: none"> ▪ Ventilation dampers (fire dampers) are in the open blade position. ▪ Evacuation/pressure relief/bypass dampers are in the closed blade position (network mode only). ▪ Red diode (OFF) indicates the damper's fail-safe position. <ul style="list-style-type: none"> ▪ Ventilation dampers (fire dampers) are in the closed blade position. ▪ Evacuation/pressure relief/bypass dampers are in the open blade position (network mode only). <p>If two dampers are connected in parallel in the same damper group, the same indication relates to both dampers.</p> <p>The dampers do not open. <i>Check:</i></p> <ul style="list-style-type: none"> ▪ That there are no other alarms on the front panel ▪ That the damper motor is connected correctly ▪ That the fuse to the damper outputs is intact (4 AT) <p>If the air handling unit moves to the fire position during the automatic damper test. Check that FAN CONTROL is connected to the correct input on the unit, marked external stop or similar.</p>
B OPERATION   	<p>Green LED showing that the unit is energised and indicating day/night mode or communication.</p> <p>Constant = day mode.</p> <p>Long flashing = night mode.</p> <p>Short flashing = communication via IS-BUS.</p>

	FUNCTION	DESCRIPTION
<p>C</p>	<p>ERROR 1/2</p> <p> </p> <p>Detector 1  </p> <p>Detector 2  </p> <p>Detector 3  </p> <p>Detector 4  </p> <p> </p> <p> </p>	<ul style="list-style-type: none"> ▪ Error 1 and 2 constantly lit if the detector loop is broken <i>Check:</i> <ul style="list-style-type: none"> ▪ The terminating resistor in the last detector of the loop with the problem. It should be 2200 Ω, 0.6 W. ▪ If the input is not used, a resistor of 2200 Ω must be installed to replace the detectors. ▪ Break in cable ▪ Check loop polarity over the entire length ▪ Alternating flashes to indicate a service alarm for the relevant input (dirty smoke detector) The indication is delayed by one hour to prevent false alarms. When the alarm is reset, the delay is deactivated to make it possible to confirm immediately that the alarm has been cleared. <i>Check:</i> <ul style="list-style-type: none"> ▪ If one or more detectors are dirty. Indicated by a yellow LED on the affected detector if the detector has a service alarm function. ▪ Error 1 is constantly lit if the damper test fails <i>Check:</i> <ul style="list-style-type: none"> ▪ Perform a manual (E) damper test and check that the relevant DAMPER indicates OFF (red) within 30 seconds after NORMAL (green) goes off. The indication must then return to NORMAL within 200 seconds. ▪ That the G0 and M cables have not been swapped and that they are connected according to the description of damper connections. ▪ That the dampers are connected in sequence from DAMPER 1 to 8 ▪ That the right number of damper groups are configured as shown in the jumper table on page 6. ▪ Error 1 and 2 flashing to indicate a communication error (IS-BUS) <i>Check:</i> <ul style="list-style-type: none"> ▪ The addressing in KUSE and that the master unit slave unit addressing is correct according to its manual. ▪ Communication loop from Gnd to Gnd, A to A and B to B between the units.
<p>D</p>	<p>FAN CONTROL</p>	<p>Normal mode for the air handling unit is indicated with the green LED FAN (CONTROL) when the relay is closed 19-21.</p> <p>If the air handling unit moves to the fire position during the automatic damper test. Check that FAN CONTROL is connected to the correct input on the unit, marked external stop or similar.</p>
<p>E</p>	<p>RESET/TEST</p> <p><i>Only relevant for stand-alone mode</i></p>	<p>RESET – press the button briefly to reset all alarms.</p> <p>TEST – carry out a manual damper test by holding down the button for longer than five seconds. The test starts when you release the button and the fan relay (FAN CONTROL) switches off. A configurable period passes before the damper test to allow any duct pressure to reduce or the reheater to cool down.</p> <p>RESET required after night mode</p> <p>Unwanted locking can occur between the KSUE and the unit when the night mode signal is received (from the unit) if jumper D is not inserted.</p>

	FUNCTION	DESCRIPTION
F	A ALARM	<p>The A alarm (fire) is indicated by the red LED and the associated relay output is closed when the following events occur.</p> <ul style="list-style-type: none"> ▪ Smoke detected by one of the detector loops (DET 1-4) ▪ Break of EXT input (external fire alarm) <p><i>Check:</i></p> <ul style="list-style-type: none"> ▪ That the EXT input is jumpered or closed by an external monitoring unit ▪ That none of the detector loops is short-circuited ▪ That an alarm from a detector is indicated with a red LED on the detector.
G	B ALARM	<p>The B alarm is indicated by the red LED and the associated relay output is closed when the following events occur:</p> <ul style="list-style-type: none"> ▪ Break in any of the detector loops ▪ Error during function test ▪ Service alarm in any of the detector loops ▪ Damper in incorrect position during normal operation ▪ Connection error <p><i>Check:</i></p> <ul style="list-style-type: none"> ▪ For other alarms indicated by the LEDs ▪ That the G0 and M cables have not been swapped and that they are connected according to the description of damper connections. ▪ That the dampers are connected in sequence from DAMPER 1 to 8 ▪ That the right number of damper groups are configured as shown in the jumper table on page 6.