

CU-LT 1S

Rectangular fire damper in fire-resistance class EI60S to EI120S

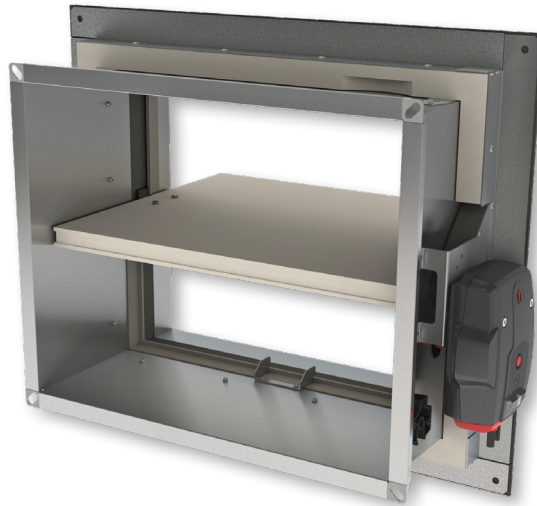

QUICK FACTS







- Fire damper in fire-resistance class EI60S to EI120S, with rectangular PG20 connection up to 800×600 mm
- EI60S – EI120S provides resistance against fire and smoke for 60 to 120 minutes depending on installation, with increased sealing (S) cold smoke, see Declaration of Performance (DoP)
- For mounting without caulking in wall/floor with various motor position in all four angles, see Declaration of Performance (DoP)
- The casing is made of galvanised steel and has leakage class C according to EN 1751
- CE approved according to product standard EN 15650
- Can be controlled with Swegon's control and monitoring products

Table of content

Declaration of performance	4
Product presentation CU-LT-1S	5
Range and dimensions CU-LT-1S	6
Evolution - kits	7
Options - at the time of order	9
Flange types - at the time of order	9
Storage and handling	10
Installation	10
Position of the thermo-electric fuse (spring-return actuator BFLT)	11
Installation at a minimal distance from another damper or from an adjacent supporting construction	11
Installation in rigid wall and floor as well as in gypsum block wall	12
Installation in flexible wall (metal stud gypsum plasterboard wall)	13
Installation remote from the wall + GEOFLAM	14
Operation and mechanisms	16
Electrical connection	20
Weights	22
Selection data	23
Example	24
Sample order	27
Approvals and certificates	28

Explanation of the abbreviations and pictograms

Wn = nominal width	E.TELE = power supply magnet	Sn = free air passage
Hn = nominal height	E.ALIM = power supply motor	ζ [-] = pressure loss coefficient
Dn = nominal diameter	V = volt	Q = airflow
E = integrity	W = watt	ΔP = static pressure drop
I = thermal insulation	Auto = automatic	v = air speed in the duct
S = smoke leakage	Tele = remote controlled	Lwa = A-weighted sound power level
Pa = pascal	Pnom = nominal capacity	Lw oct = sound power level per octave midband
ve = vertical wall penetration	Pmax = maximum capacity	dB(A) = A-weighted decibel value
ho = horizontal floor penetration	GKB (type A) / GKF (type F): "GKB"	ΔL = correction factor
o -> i = meets the criteria from the outside (o) to the inside (i)	stands for standard plasterboards (type A according to EN 520) while "GKF"	
i <-> o = fire side not important	plasterboards offer a higher fire resistance for a similar plate thickness (type F according to EN 520)	
V AC = Volt alternating current	Cal-Sil = calcium silicate	
V DC = Volt direct current	OP = option (delivered with the product)	
	KIT = kit (delivered separately for repair or upgrade)	
	PG = connection flange to the duct	

	fast installation		optimal acoustic performance
	optimal free air passage and minimal pressure loss		air-tightness class C according to EN1751
	suitable for surface-mount		suitable for installation remote from the wall
	intermediate dimensions on request		

DECLARATION OF PERFORMANCE

CE_DOP_Rf-t_C14_EN - F-01/01/2024

1. Unique identification code of the product-type:	CU-LT-1S
2. Intended use/s:	Rectangular fire damper to be used in conjunction with partitions to maintain fire compartments in heating, ventilating and air conditioning installations.
3. Manufacturer:	Rf-Technologies NV, Lange Ambachtstraat 40, B-9860 Oosterzele
4. System/s of AVCP:	System 1
5. Harmonised standard / European Assessment Document: notified body / European Technical Assessment, Technical Assessment Body, notified body, certificate of constancy of performance:	EN 15650:2010, BCCA with identification number 0749; BCCA-0749-CPR-BC1-606-0464-15650.06-0464
6. Declared performance according to EN 15650:2010	(Fire resistance according to EN 1366-2 and classifications according to EN 13501-3)

Essential characteristics	Sealing		Performance	
	Wall	Installation	Classification	Performance
Range 200x100 mm ≤ CU-LT-1s ≤ 800x600 mm	Aerated concrete ≥ 100 mm	1	EI 120 (V _{e,i} ↔ o) S - (500 Pa)	
	Not applicable	2	EI 120 (V _{e,i} ↔ o) S - (500 Pa)	
	Metal studs/gypsum plasterboard Type A (EN 520) ≥ 100 mm	1	EI 60 (V _{e,i} ↔ o) S - (500 Pa)	
	Metal studs/gypsum plasterboard Type F (EN 520) ≥ 100 mm	1	EI 90 (V _{e,i} ↔ o) S - (500 Pa)	
	Gypsum blocks ≥ 70 mm	1	EI 120 (V _{e,i} ↔ o) S - (500 Pa)	
	Aerated concrete ≥ 150 mm	1	EI 120 (h _{0,i} ↔ o) S - (500 Pa)	

1	Type of installation: surface-mounted, 0/90/180/270°	2	Type of installation: remote from the wall, 0/180°
---	--	---	--

Nominal activation conditions/sensitivity:	Pass
Response delay (response time): closure time	Pass
Operational reliability: cycling	MFLSP - 50 cycles; MMAG - 300 cycles; BFL(T) - 10000 cycles; ONE - 10000 cycles; ONEX - 10000 cycles; UNIQ - 10000 cycles
Durability of response delay:	Pass
Durability of operational reliability:	Pass
Protection against corrosion according to EN 60068-2-52:	Pass
Damper casing leakage according to EN 1751:	≥ class C

The performance of the product identified above is in conformity with the set of declared performance/s. This declaration of performance is issued, in accordance with Regulation (EU) No 305/2011, under the sole responsibility of the manufacturer identified above.

Signed for and on behalf of the manufacturer by:
Frank Verhinderen, Head of Product Management



Oosterzele, 01/01/2024

Harmonised standard
EN 15650:2010

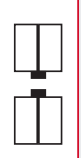

Product presentation CU-LT-1S

Optimised rectangular surface-mounted fire damper with a fire resistance up to 120 minutes. CU-LT-1s combines the energy efficiency of our range of optimised dampers (minimum pressure loss, small dimensions) with the ease and speed of a dry assembly. Easy to mount and light in weight, CU-LT-1s is the ideal solution for renovation projects and, in general, for building sites where access to the damper is difficult or impossible from one of the wall sides (terminal damper).

Fire dampers are installed where air ducts penetrate fire-resistant compartment walls. Their role is to restore the fire resistance grade of the penetrated wall and to prevent smoke propagation. Fire dampers are distinguished by their degree of fire resistance, by their aeraulic properties as well as by their installation ease. Rf-Technologies' fire dampers are all CE marked. They can be equipped with various types of mechanisms depending on the specific needs linked to the project or to the local regulations.

- ✓ fast installation
- ✓ optimal free air passage and minimal pressure loss
- ✓ optimal acoustic performance
- ✓ higher net building volume through compact size
- ✓ air-tightness class C according to EN1751



- tested according to EN 1366-2 up to 500 Pa
- suitable for surface-mounting on rigid wall, rigid floor and light wall (metal stud gypsum plasterboard wall, gypsum blocks)
- suitable for installation remote from the wall
- operating mechanism outside the wall
- maintenance-free
- for indoor use
- intermediate dimensions on request
- operating temperature: max. 50°C

1. casing in galvanised steel
2. damper blade
3. operating mechanism
4. sealing cold smoke
5. intumescent strip
6. connection flange PG20
7. surface-mounting frame
8. product identification
9. bolt and cage nut

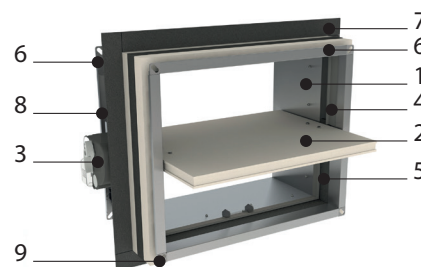

Range and dimensions CU-LT-1S

Exceeding blade: X = on the mechanism side, Y = on the wall side

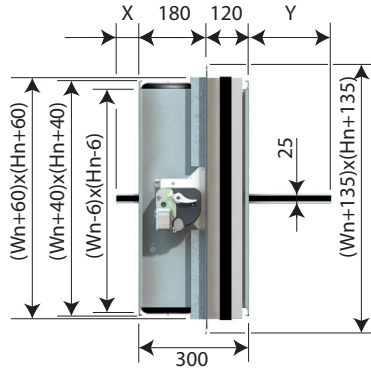

Hn (mm)	150	200	250	300	350	400	450	500	550	600
x	-	-	-	-	-	-	-	17	42	67
y	2	27	52	77	102	127	152	177	202	227

(W x H) mm	IV	V
	200x100	800x600





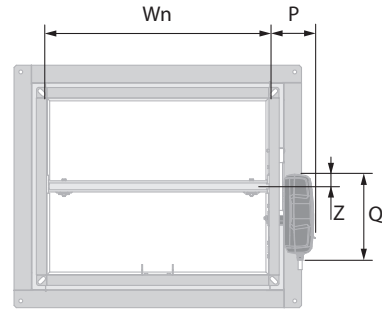
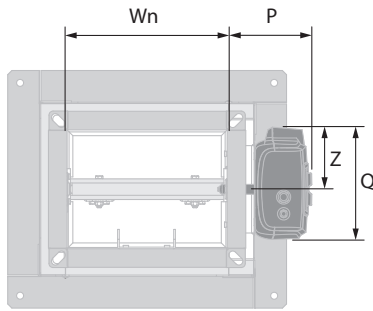

Hn < 400 mm

Hn ≥ 400 mm

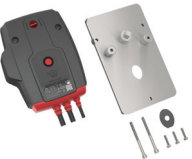



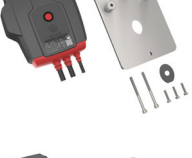

	MFUSP	ONE (X)	BFL(T)		MFUSP	ONE (X)	BFL(T)
P	101	97	81	P	101	97	81
Q	122	136	80	Q	123	191	80
Z	61	75	40	Z	28	27	40

Evolution - kits

	KIT MFUSP	Automatic unlocking mechanism with fusible link
	KIT ONE T 24 FDCB	Spring return actuator ONE 24V (with fusible link T) + bipolar beginning- and end-of-range switch
	KIT ONE T 24 FDCU	Spring return actuator ONE 24V (with fusible link T) + unipolar beginning- and end-of-range switch
	KIT ONE T 24 FDCU ST	Spring return actuator ONE 24V (with fusible link T) + unipolar beginning- and end-of-range switch + plug (ST)
	KIT ONE T 230 FDCB	Spring return actuator ONE 230V (with fusible link T) + bipolar beginning- and end-of-range switch
	KIT ONE T 230 FDCU	Spring return actuator ONE 230V (with fusible link T) + unipolar beginning- and end-of-range switch
	KIT ONE T 230 FDCU ST	Spring return actuator ONE 230V (with fusible link T) + unipolar beginning- and end-of-range switch + plug (ST)
	KIT ONE-X 24	Spring return actuator ONE-X 24V (with fusible link T)
	KIT ONE-X 230	Spring return actuator ONE-X 230V (with fusible link T)

	KIT BFL24	Spring return actuator BFL 24V
	KIT BFL24-ST	Spring return actuator BFL 24V with plug (ST)
	KIT BFL230	Spring return actuator BFL 230V
	KIT BFLT24	Spring return actuator BFL 24V with thermo-electric fuse (T)
	KIT BFLT24-ST	Spring return actuator BFL 24V with thermo-electric fuse (T) and plug (ST)
	KIT BFLT230	Spring return actuator BFL 230V with thermo-electric fuse (T)
	KIT BFLT230-ST	Spring return actuator BFL 230V with thermo-electric fuse (T)
	KIT BFN24	Spring return actuator BFN 24V (BFN kits must be used instead of BFL kits for fire dampers produced before 1/7/2015)
	KIT FDCU MFUS(P)	Limit switch 'open/closed'

	KIT SN2 BFL/BFN	Auxiliary limit switch 'open/closed'
	KIT ZBAT 72	Black spare part for thermo-electric fuse for BFLT/BFNT
	KIT FUS 72 MFUS(P)	Fusible link 72°C
	FUS72 ONE	Fusible link 72°C
	MECT	Testbox for mechanisms 24/48 V (magnet, motor, beginning and end of range switches)

Options - at the time of order

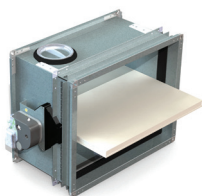

UL	Inspection shutter (set of 2)
-----------	-------------------------------

Flange types - at the time of order

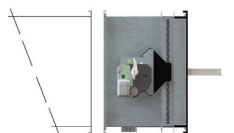

PG20	Connection to ducts with 20 mm flanges (either with sliding profile or with bolts). Elliptical holes $\varnothing 9,5 \times 16$ mm.
-------------	--

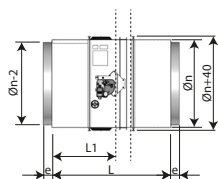

PRJ	Circular connection with rubber sealing ring on a rectangular damper with PG20 flange.
------------	--

Storage and handling

As this product is a safety element, it should be stored and handled with care.

Avoid:

- any kind of impact or damage
- contact with water
- deformation of the casing

It is recommended:

- to unload in a dry area
- not to flip or roll the product to move it
- not to use the damper as a scaffold, working table, etc.
- not to store smaller dampers inside larger ones

Installation

General points

- The installation must comply with the installation manual and the classification report.
- Axis orientation: see the declaration of performance.
- Avoid obstruction of adjoining ducts.
- Product installation: always with closed damper blade.
- Verify if the blade can move freely.
- Please observe safety distances with respect to other construction elements. The operating mechanism must also remain accessible: allow for a clearance of 200 mm around the housing.
- The air tightness class will be maintained if the damper is installed according to the installation manual.
- Rf-t fire dampers are always tested in standardised constructions according to EN 1366-2. The achieved results are valid for similar supporting constructions with a fire resistance, thickness and density equal or superior to the supporting construction used during the test.
- If the wall thickness exceeds the minimum thickness specified in our installation instructions, the following conditions apply to the sealing depth:
 - For flexible walls and sandwich panel system walls, the seal must always be applied over the full depth of the wall.
 - With rigid walls, rigid floors and plaster block walls, the minimum sealing depth as indicated in our installation instructions (often equal to the minimum wall thickness) is sufficient. Apply the seal at the height of the damper blade (from the wall limit indication).
- When installing a fire damper in a flexible metal stud wall, some installation methods do not require reinforcing profiles around the wall opening from a fire protection point of view (see below). Always follow the general instructions of the manufacturer of these wall systems when building this type of wall.
- The damper must remain accessible for inspection and maintenance.
- Schedule at least 2 visual checks each year.

	TEST	
2021	<input checked="" type="checkbox"/>	<input checked="" type="checkbox"/>
2022	<input checked="" type="checkbox"/>	<input type="checkbox"/>
2023	<input type="checkbox"/>	<input type="checkbox"/>
2024	<input type="checkbox"/>	<input type="checkbox"/>
2025	<input type="checkbox"/>	<input type="checkbox"/>

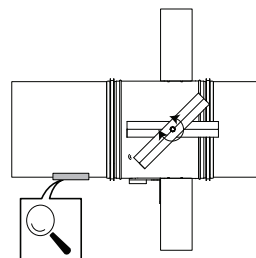

Position of the thermo-electric fuse (spring-return actuator BFLT)

1

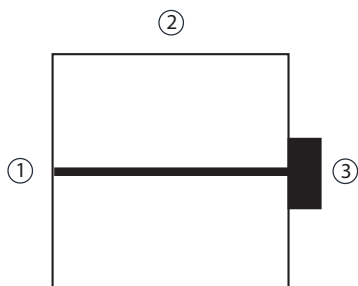

1. Position of the thermo-electric fuse on the damper casing: 1. on opposite side of mechanism if $H < 250$ mm and $W < 250$ mm; 2. on top if $H < 250$ mm and $W \geq 250$ mm; 3. on mechanism side if $H \geq 250$ mm.

Installation at a minimal distance from another damper or from an adjacent supporting construction

1

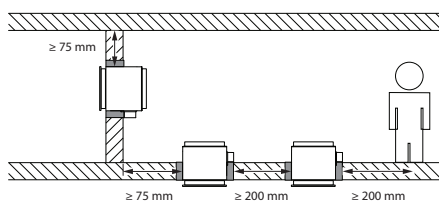

1. Principle
 According to the European test standard, a fire damper must be installed at a minimum distance of 75 mm from an adjacent wall and 200 mm from another damper, unless the solution was tested at a shorter distance.

Installation in rigid wall and floor as well as in gypsum block wall

The product was tested and approved in:

Range	Wall type		Sealing	Classification
$200 \times 100 \text{ mm} \leq \text{CU-LT-1s} \leq 800 \times 600 \text{ mm}$	Rigid wall	Aerated concrete $\geq 100 \text{ mm}$	Not applicable	EI 120 (v_e i \leftrightarrow o) S - (500 Pa)
$200 \times 100 \text{ mm} \leq \text{CU-LT-1s} \leq 800 \times 600 \text{ mm}$	Rigid floor	Aerated concrete $\geq 150 \text{ mm}$	Not applicable	EI 120 (h_o i \leftrightarrow o) S - (500 Pa)
$200 \times 100 \text{ mm} \leq \text{CU-LT-1s} \leq 800 \times 600 \text{ mm}$	Flexible wall	Gypsum blocks $\geq 70 \text{ mm}$	Not applicable	EI 120 (v_e i \leftrightarrow o) S - (500 Pa)

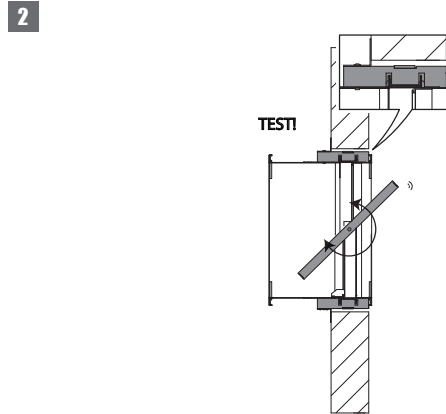
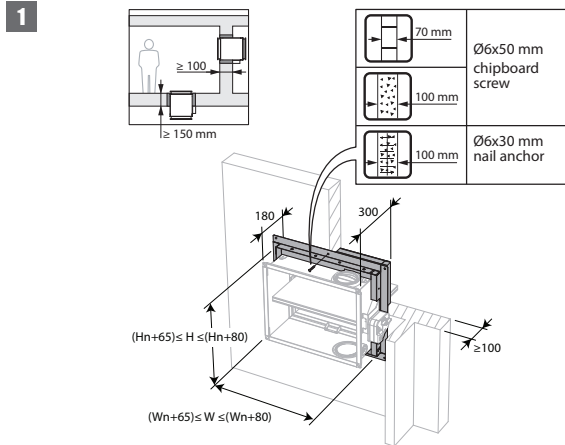

Installation in flexible wall (metal stud gypsum plasterboard wall)

The product was tested and approved in:

Range	Wall type	Sealing	Classification
$200 \times 100 \text{ mm} \leq \text{CU-LT-1s} \leq 800 \times 600 \text{ mm}$	Flexible wall	Metal studs gypsum plasterboard Type F (EN 520) $\geq 100 \text{ mm}$	Not applicable
$200 \times 100 \text{ mm} \leq \text{CU-LT-1s} \leq 800 \times 600 \text{ mm}$	Flexible wall	Metal studs gypsum plasterboard Type A (EN 520) $\geq 100 \text{ mm}$	Not applicable

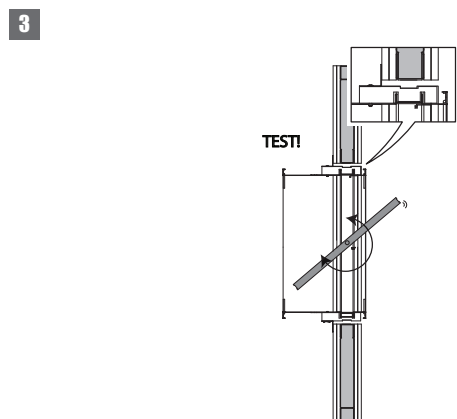
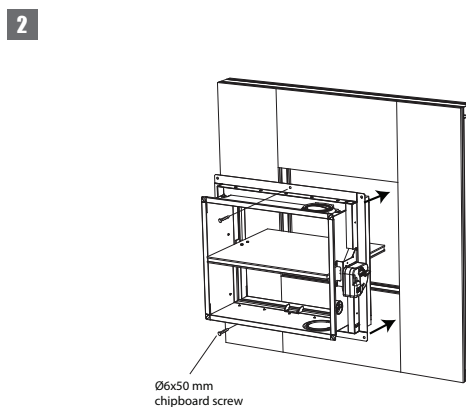
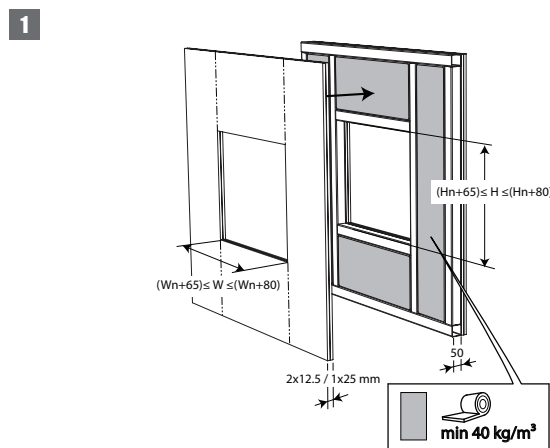

Installation remote from the wall + GEOFLAM

The product was tested and approved in:

Range	Wall type	Sealing	Classification
$200 \times 100 \text{ mm} \leq \text{CU-LT-1s} \leq 800 \times 600 \text{ mm}$	Rigid wall	Galvanised duct + GEOFLAM® F 45 mm + mortar	EI 120 ($v_e i \leftrightarrow o$) S - (500 Pa)

1

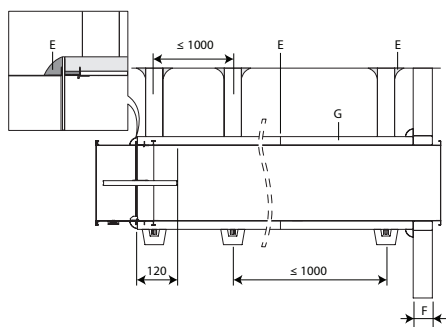

2

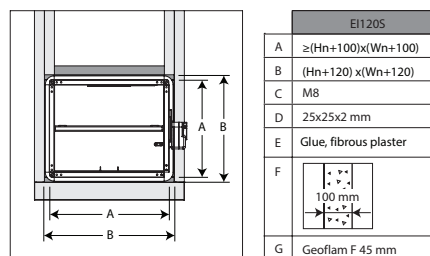

3

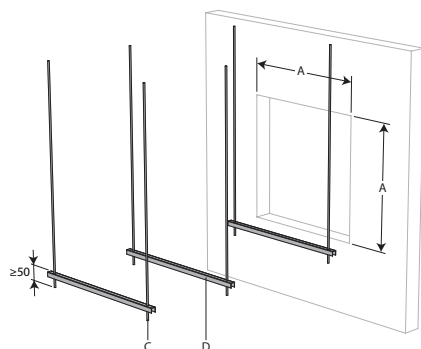

4

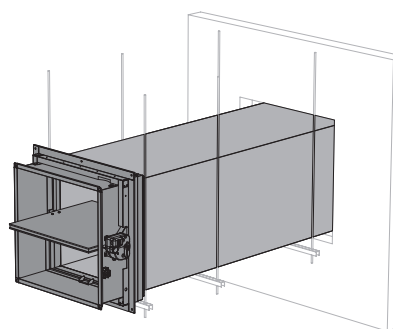

3. An opening with maximal dimensions "A" is made in the wall.

4. The fire damper is mounted remote from the wall at the end of a metal duct. The duct is supported every 1000 mm. The suspensions consist of threaded rods "C" and U-shaped steel profiles "D". A free space of maximum 25 mm is left between the threaded rods and the vertical walls of the casing "B".

5

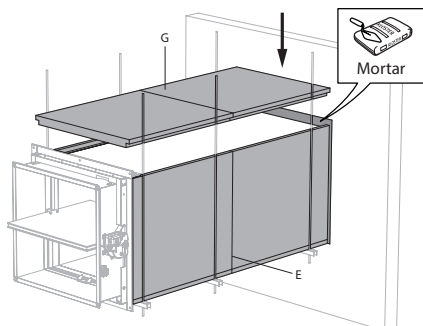

5. The opening around the duct is sealed with standard mortar. The duct is covered with 45 mm thick GEOFLAM F plates or 35 mm thick GEOFLAM Light plates "G". The plates adhere to each other with glue and fibrous plaster "E". The damper casing is also covered on a length of 120 mm.

6

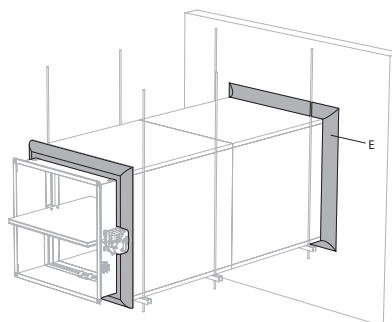

6. The GEOFLAM F plates stop at a distance of 15 mm from the wall. The free space is filled with fibrous plaster. The same filling is applied to seal off the connection between the GEOFLAM F plates and the damper casing.

7

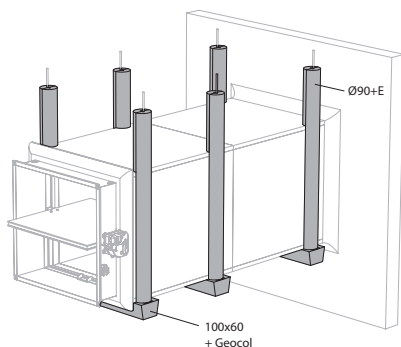

7. The threaded rods are covered with U-shaped plates of GEOFLAM (Ø 90 mm) and affixed with glue and fibrous plaster. The profiles are covered with U-shaped shells GEOFLAM 100 x 60 mm, which are affixed to the underside of the shaft with GEOCOL (GEOSTAFF) cement plaster.

8

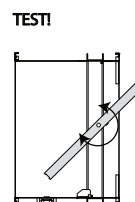

Maintenance

- No specific maintenance required.
- Schedule at least 2 visual checks each year.
- Remove dust and all other particles before use.
- Follow local maintenance regulations (i.e. BS9999 Annex V; NF S 61-933) and EN13306.
- Read the maintenance instructions on our website:
https://www.rft.eu/assets/PIM/DOCUMENTS/BROCHURE%20KITS/BRO_K139_MAINTENANCE_C.pdf
- Use the damper at up to 95% humidity, non-condensing.
- The fire damper can be cleaned with a dry or slightly damp cloth. It is forbidden to use abrasive cleaners or mechanical cleaning techniques (brush).

Operation and mechanisms



MFUS(P) Mechanism with fusible link

The operating mechanism MFUS(P) automatically unlocks the blade when the temperature in the duct exceeds 72°C. The damper can also be unlocked and reset manually.

1. unlocking button
2. resetting handle
3. cable entrance

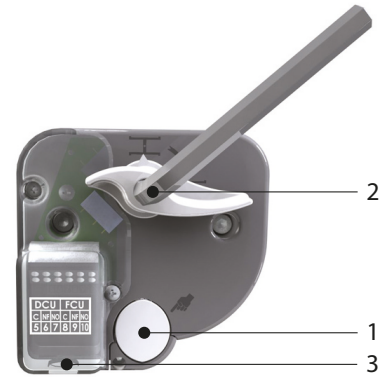

Options - at the time of order

FDCU Limit switch 'open/closed'

Unlocking

- **manual unlocking:** press the unlocking button (1).
- **automatic unlocking:** the fusible link melts when the temperature reaches 72°C in the duct.
- **remote unlocking:** n/a

Resetting

- **manual resetting:** turn the resetting handle (2) 90° clockwise (or use a 10 mm hex key).
- **motorised resetting:** n/a

Caution:

- ▲ The mechanism may never be tested on its own, without being attached to the damper. Such a test might damage the mechanism or the operator might be injured.



ONE Spring return actuator for remote control

The spring-return actuator ONE is designed to easily operate Rf-t fire dampers of all sizes, automatically or remotely. Six models are available, 24 or 230 volt, with FDCU or FDCB position switches; and optionally with plug (ST).

- 1. unlocking button
- 2. blade position indicator
- 3. LED
- 4. battery compartment to reset motor

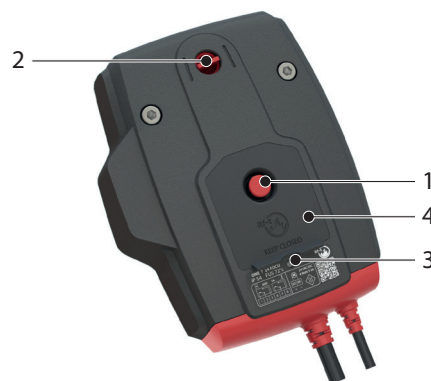

Unlocking

- **manual unlocking:** shortly press the unlocking button (1) once.
- **automatic unlocking:** the fusible link reacts as soon as the temperature in the duct reaches 72°C.
- **remote unlocking:** by interrupting the power supply.

Resetting

- **manual resetting:** open the battery compartment (4) and press a 9V battery against the contact springs. Hold this position until the LED (3) emits a continuous light.
Check whether the indicator (2) shows that the damper blade is in the open position.
Remove the battery, the LED fades away.
Close the battery compartment.
- **motorised resetting:** switch off the power supply for at least 5 sec. Power the actuator (respect the prescribed voltage) for at least 75 sec. The resetting stops automatically when the end of range is reached (damper open).

Caution:

- ⚠ If the LED (3) flickers fast (3x/sec.), the battery is discharged: use a new battery.
- ⚠ If the LED (3) flickers slowly (1x/sec), the resetting is in progress.
- ⚠ If the LED (3) is continuously on, the resetting is complete and the motor is powered.
- ⚠ If the actuator detects voltage on the power cable, a brief contact of the battery is enough to start the resetting process.
- ⚠ The power supply of this actuator cannot be individually replaced. If the cable is damaged, the whole unit must be discarded and replaced.
- ⚠ The housing of the mechanism contains a temperature sensor. When the temperature in the housing exceeds 72°C, the mechanism unlocks. The LED flashes twice per second. When the temperature drops below 72°C, the mechanism can only be reset in a motorised manner after a manual reset (with a battery).
- ⚠ The end of range switches need 1 second after operation to adopt a stable position.
- ⚠ Make sure the thermal trigger device is present in the actuator. The actuator might not function properly if this is not the case.

	prod. < 1/7/2015				prod. ≥ 1/7/2015			
	CR60(1s) CR120	CU-LT CU-LT-1s	CR2≤400 CU2≤1200	CR2>400 CU2>1200	CR60(1s) CR120(1s)	CU-LT CU-LT-1s	CR2≤400 CU2≤1200	CR2>400 CU2>1200
Kit ONE	●	●	●		●	●	●	●



ONE-X Spring return actuator with integrated communication module.

The ONE-X is a spring return actuator with integrated communication module designed to simply operate Rf-t fire dampers of all sizes, automatically or remotely. The ONE-X is available in two versions: 24 V and 230 V.

1. unlocking button
2. blade position indicator
3. LED red: status
4. battery compartment
5. LED blue: communication
6. LED orange: error message
7. supply
8. bus cable

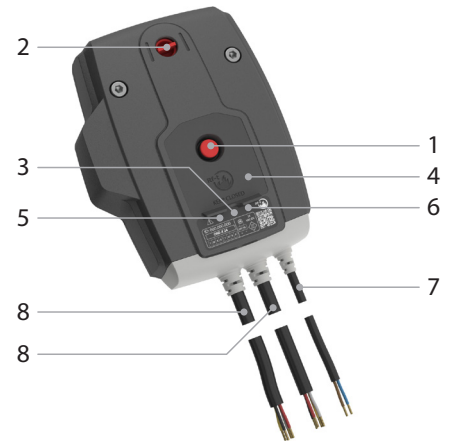

Unlocking

- **manual unlocking:** shortly press the unlocking button (1) once.
- **automatic unlocking:** the fusible link reacts as soon as the temperature in the duct reaches 72°C.
- **remote unlocking:** via ZENiX controller

Resetting

- **manual resetting:** Open the battery compartment (4) and press a 9V battery against the contact springs. Hold this position until the red LED (3) emits a continuous light. Control whether the indicator (2) indicates that the damper blade is open. Remove the battery. Close the battery compartment.
- **motorised resetting:** via ZENiX controller. By applying voltage during first use.

Caution:

- ⚠ If the ONE-X detects voltage on the power cable, a brief contact of the battery is enough to start the resetting process, provided the ZENiX controller has sent the damper to open position or the ONE-X is being operated for the first time.
- ⚠ The power supply of this actuator cannot be individually replaced. If the cable is damaged, the whole unit must be discarded and replaced.
- ⚠ The housing of the mechanism contains a temperature sensor. When the temperature in the housing exceeds 72°C, the mechanism unlocks. The LED flashes twice per second. When the temperature drops below 72°C, the mechanism can only be reset in a motorised manner after a manual reset (with a battery).
- ⚠ The end of range switches need 1 second after operation to adopt a stable position.

Safety regulations:

- ⚠ Do not use the ONE-X for any application other than the specified applications, in particular not in aircraft or other airborne vehicles.
- ⚠ The company that purchases and/or installs the ONE-X is fully responsible for the correct operation of the entire system. Only authorised specialists may perform the installation. All rules and regulations, including statutory regulations, must be observed during installation.
- ⚠ This device contains electrical or electronic components and must not be disposed of as household waste. All locally applicable regulations and requirements must be strictly observed.



BFL(T) Remotely controlled spring return actuator

The spring return actuator BFL(T) is especially designed to operate fire dampers remotely. The BFL(T) variant is intended for fire dampers with smaller dimensions (CR60, CR120, CR2 with $\varnothing \leq 400$ mm, CRS60 with $\varnothing \leq 315$ mm, CU2 / CU2-15 / CU4 with $B+H \leq 1200$ mm or for CU-LT and CU-LT-1s). For Markage FD with $H = 200$ mm or $H = 2200$ mm (in combination with BFT motor).

- 1. locking button
- 2. plug (ST)
- 3. access for manual resetting
- 4. thermo-electric tripping device (T)

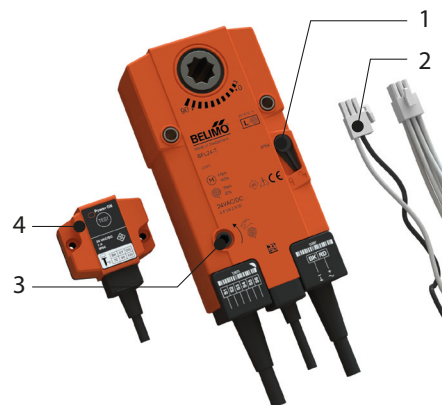

Options - at the time of order

SN2 BFL/BFN Auxiliary limit switch 'open/closed'

Unlocking

- **manual unlocking:** place the locking button on "unlock". (In case of BFLT: the damper can alternatively be unlocked by pushing the "test" button on the thermo-electric fuse)
- **automatic unlocking:** the thermo-electric fuse reacts as soon as the temperature reaches 72°C (type BFLT).
- **remote unlocking:** by interrupting the power supply.

Caution:

⚠ The thermo-electric fuse will not move the damper into its safety position (when the temperature reaches 72°C) if the motor is not powered.

Resetting

- **manual resetting:** turn the enclosed handle anti-clockwise. To block the motor, place the locking button on "lock"
- **motorised resetting:** switch off the power supply for at least 10 seconds. Supply the actuator (respect the prescribed voltage) for at least 75 seconds. The resetting stops automatically when the end of range is reached (damper open) - it takes about 60 seconds to reset the damper - or when the power supply is interrupted.

Caution:

- ⚠ Do not use a drill or powered screwdriver.
- ⚠ Stop as soon as the motor is completely rearmed (end of range).

	prod. < 1/7/2015				prod. ≥ 1/7/2015			
	CR60(1s) CR120	CU-LT CU-LT-1s	CR2≤400 CU2≤1200	CR2>400 CU2>1200	CR60(1s) CR120 (1s)	CU-LT CU-LT-1s	CR2≤400 CU2≤1200	CR2>400 CU2>1200
Kit BFL					●	●	●	
Kit BFN	●	●	●					●
Kit BF				●				

Electrical connection

MFUS(P)

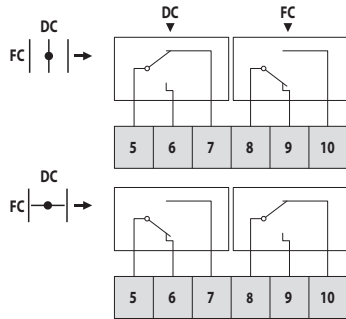

DC : Switch open position fire damper
 FC : Switch closed position fire damper

ONE

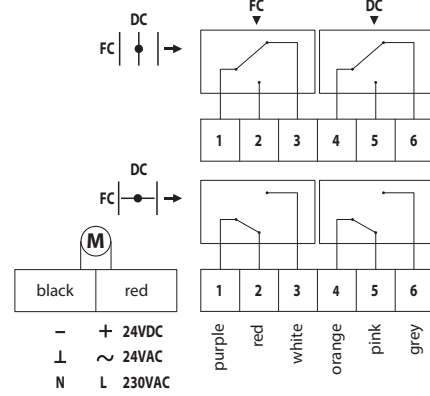

DC : Switch open position fire damper
 FC : Switch closed position fire damper

ONE-X

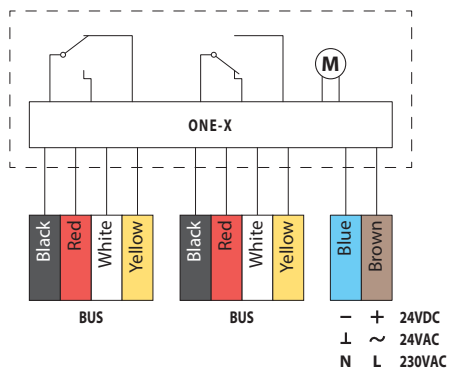

BFL(T)

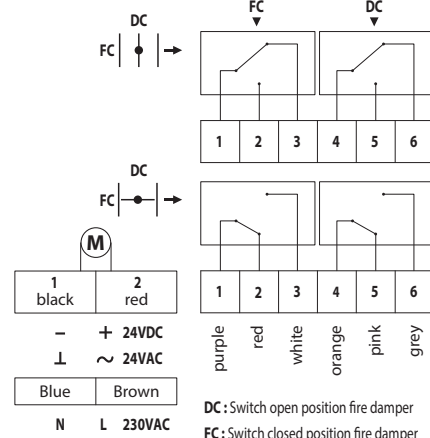

DC : Switch open position fire damper
 FC : Switch closed position fire damper

MEC	Nominal voltage motor	Nominal voltage magnet	Power consumption (stand-by)	Power consumption (operating)	Standard switches	Resetting time motor
MFUSP	N/A	N/A	N/A	N/A	1mA...1A, DC 5V...AC 48V	N/A
ONE T 24 FDCU	24 V AC/DC (-10/+20%)	N/A	0,28 W	4,2 W	1mA...1A 60V	< 75 s (cabled) / <85 s (battery)
ONE T 24 FDCU ST	24 V AC/DC (-10/+20%)	N/A	0,28 W	4,2 W	1mA...1A 60V	< 75 s (cabled) / <85 s (battery)
ONE T 230 FDCU	230 V AC (-15/+15%)	N/A	0,57 W	4,2 W	1mA...100mA 230V	< 75 s (cabled) / <85 s (battery)
ONE T 230 FDCU ST	230 V AC (-15/+15%)	N/A	0,57 W	4,2 W	1mA...100mA 230V	< 75 s (cabled) / <85 s (battery)
ONE T 24 FDCB	24 V AC/DC (-10/+20%)	N/A	0,28 W	4,2 W	1mA...1A 60V	< 75 s (cabled) / <85 s (battery)
ONE T 230 FDCB	230 V AC (-15/+15%)	N/A	0,57 W	4,2 W	1mA...1A 60V	< 75 s (cabled) / <85 s (battery)
ONE-X 24	24 V AC/DC (-10/+20%)	N/A	0,28 W	4,2 W		< 75 s (cabled) / <85 s (battery)
ONE-X 230	230 V AC (-15/+15%)	N/A	0,57 W	4,2 W		< 75 s (cabled) / <85 s (battery)
BFL24	24 V AC/DC	N/A	0,7 W	2,5 W	1mA...3A, AC 250V	< 60 s
BFL24-ST	24 V AC/DC	N/A	0,7 W	2,5 W	1mA...3A, AC 250V	< 60 s
BFL230	230 V AC	N/A	0,9 W	3 W	1mA...3A, AC 250V	< 60 s
BFLT24	24 V AC/DC	N/A	0,8 W	2,5 W	1mA...3A, AC 250V	< 60 s
BFLT24-ST	24 V AC/DC	N/A	0,8 W	2,5 W	1mA...3A, AC 250V	< 60 s
BFLT230	230 V AC	N/A	1,1 W	3,5 W	1mA...3A, AC 250V	< 60 s
BFLT230-ST	230 V AC	N/A	1,1 W	3,5 W	1mA...3A, AC 250V	< 60 s

MEC	Running time spring	Noise level motor	Noise level spring	Cable supply / control	Cable auxiliary switch	Protection class
MFUSP	1 s	N/A	N/A			IP 42
ONE T 24 FDCU	< 30 s	< 64 dB (A)	< 67 dB (A)	1 m, 2 x 0.75 mm ² (halogen-free)	1 m, 6 x 0.75 mm ² (halogen-free)	IP 54
ONE T 24 FDCU ST	< 30 s	< 64 dB (A)	< 67 dB (A)	1 m, 2 x 0.75 mm ² (halogen-free)	1 m, 6 x 0.75 mm ² (halogen-free)	IP 54
ONE T 230 FDCU	< 30 s	< 64 dB (A)	< 67 dB (A)	1 m, 2 x 0.75 mm ² (halogen-free)	1 m, 6 x 0.75 mm ² (halogen-free)	IP 54
ONE T 230 FDCU ST	< 30 s	< 64 dB (A)	< 67 dB (A)	1 m, 2 x 0.75 mm ² (halogen-free)	1 m, 6 x 0.75 mm ² (halogen-free)	IP 54
ONE T 24 FDCB	< 30 s	< 64 dB (A)	< 67 dB (A)	1 m, 2 x 0.75 mm ² (halogen-free)	(2x) 1 m, 6 x 0,75 mm ² (halogen-free)	IP 54
ONE T 230 FDCB	< 30 s	< 64 dB (A)	< 67 dB (A)	1 m, 2 x 0.75 mm ² (halogen-free)	(2x) 1 m, 6 x 0,75 mm ² (halogen-free)	IP 54
ONE-X 24	< 30 s	< 64 dB (A)	< 67 dB (A)	1 m, 2 x 0.75 mm ² (halogen-free)	bus cable: (2x) 1 m, 4 x 0,75 mm ² (halogen-free)	IP 54
ONE-X 230	< 30 s	< 64 dB (A)	< 67 dB (A)	1 m, 2 x 0.75 mm ² (halogen-free)	bus cable: (2x) 1 m, 4 x 0,75 mm ² (halogen-free)	IP 54
BFL24	20 s	< 43 dB (A)	< 62 dB (A)	1 m, 2 x 0.75 mm ² (halogen-free)	1 m, 6 x 0.75 mm ² (halogen-free)	IP 54
BFL24-ST	20 s	< 43 dB (A)	< 62 dB (A)	1 m, 2 x 0.75 mm ² (halogen-free)	1 m, 6 x 0.75 mm ² (halogen-free)	IP 54
BFL230	20 s	< 43 dB (A)	< 62 dB (A)	1 m, 2 x 0.75 mm ² (halogen-free)	1 m, 6 x 0.75 mm ² (halogen-free)	IP 54
BFLT24	20 s	< 43 dB (A)	< 62 dB (A)	1 m, 2 x 0.75 mm ² (halogen-free)	1 m, 6 x 0.75 mm ² (halogen-free)	IP 54
BFLT24-ST	20 s	< 43 dB (A)	< 62 dB (A)	1 m, 2 x 0.75 mm ² (halogen-free)	1 m, 6 x 0.75 mm ² (halogen-free)	IP 54
BFLT230	20 s	< 43 dB (A)	< 62 dB (A)	1 m, 2 x 0.75 mm ² (halogen-free)	1 m, 6 x 0.75 mm ² (halogen-free)	IP 54
BFLT230-ST	20 s	< 43 dB (A)	< 62 dB (A)	1 m, 2 x 0.75 mm ² (halogen-free)	1 m, 6 x 0.75 mm ² (halogen-free)	IP 54

Weights

CU-LT-1S + MFUSP

Hn\Wn (mm)		200	250	300	350	400	450	500	550	600	650	700	750	800		
100	kg	6,6	7,3	8,0	8,7	9,4	10,2	10,9	11,6	12,3	13,0	13,7	14,4	15,2		
150	kg	7,5	8,3	9,1	10,0	10,8	11,6	12,4	13,3	14,1	14,9	15,7	16,6	17,4		
200	kg	8,4	9,4	10,3	11,2	12,2	13,1	14,0	14,9	15,9	16,8	17,7	18,7	19,6		
250	kg	9,4	10,4	11,4	12,5	13,5	14,5	15,6	16,6	17,7	18,7	19,7	20,8	21,8		
300	kg	10,3	11,4	12,6	13,7	14,9	16,0	17,1	18,3	19,4	20,6	21,7	22,9	24,0		
350	kg	11,2	12,5	13,7	15,0	16,2	17,5	18,7	20,0	21,2	22,5	23,7	25,0	26,2		
400	kg	12,2	13,5	14,9	16,2	17,6	18,9	20,3	21,6	23,0	24,4	25,7	27,1	28,4		
450	kg	13,1	14,5	16,0	17,5	18,9	20,4	21,9	23,3	24,8	26,2	27,7	29,2	30,6		
500	kg	14,0	15,6	17,1	18,7	20,3	21,9	23,4	25,0	26,6	28,1	29,7	31,3	32,8		
550	kg	14,9	16,6	18,3	20,0	21,6	23,3	25,0	26,7	28,4	30,0	31,7	33,4	35,1		
600	kg	15,9	17,7	19,4	21,2	23,0	24,8	26,6	28,4	30,1	31,9	33,7	35,5	37,3		

CU-LT-1S + ONE T

Hn\Wn (mm)		200	250	300	350	400	450	500	550	600	650	700	750	800		
100	kg	7,8	8,5	9,2	9,9	10,6	11,4	12,1	12,8	13,5	14,2	14,9	15,6	16,4		
150	kg	8,7	9,5	10,3	11,2	12,0	12,8	13,6	14,5	15,3	16,1	16,9	17,8	18,6		
200	kg	9,6	10,6	11,5	12,4	13,4	14,3	15,2	16,1	17,1	18,0	18,9	19,9	20,8		
250	kg	10,6	11,6	12,6	13,7	14,7	15,7	16,8	17,8	18,9	19,9	20,9	22,0	23,0		
300	kg	11,5	12,6	13,8	14,9	16,1	17,2	18,3	19,5	20,6	21,8	22,9	24,1	25,2		
350	kg	12,4	13,7	14,9	16,2	17,4	18,7	19,9	21,2	22,4	23,7	24,9	26,2	27,4		
400	kg	13,4	14,7	16,1	17,4	18,8	20,1	21,5	22,8	24,2	25,6	26,9	28,3	29,6		
450	kg	14,3	15,7	17,2	18,7	20,1	21,6	23,1	24,5	26,0	27,4	28,9	30,4	31,8		
500	kg	15,2	16,8	18,3	19,9	21,5	23,1	24,6	26,2	27,8	29,3	30,9	32,5	34,0		
550	kg	16,1	17,8	19,5	21,2	22,8	24,5	26,2	27,9	29,6	31,2	32,9	34,6	36,3		
600	kg	17,1	18,9	20,6	22,4	24,2	26,0	27,8	29,6	31,3	33,1	34,9	36,7	38,5		

CU-LT-1S + ONE-X

Hn\Wn (mm)		200	250	300	350	400	450	500	550	600	650	700	750	800		
100	kg	7,8	8,5	9,2	9,9	10,6	11,4	12,1	12,8	13,5	14,2	14,9	15,6	16,4		
150	kg	8,7	9,5	10,3	11,2	12,0	12,8	13,6	14,5	15,3	16,1	16,9	17,8	18,6		
200	kg	9,6	10,6	11,5	12,4	13,4	14,3	15,2	16,1	17,1	18,0	18,9	19,9	20,8		
250	kg	10,6	11,6	12,6	13,7	14,7	15,7	16,8	17,8	18,9	19,9	20,9	22,0	23,0		
300	kg	11,5	12,6	13,8	14,9	16,1	17,2	18,3	19,5	20,6	21,8	22,9	24,1	25,2		
350	kg	12,4	13,7	14,9	16,2	17,4	18,7	19,9	21,2	22,4	23,7	24,9	26,2	27,4		
400	kg	13,4	14,7	16,1	17,4	18,8	20,1	21,5	22,8	24,2	25,6	26,9	28,3	29,6		
450	kg	14,3	15,7	17,2	18,7	20,1	21,6	23,1	24,5	26,0	27,4	28,9	30,4	31,8		
500	kg	15,2	16,8	18,3	19,9	21,5	23,1	24,6	26,2	27,8	29,3	30,9	32,5	34,0		
550	kg	16,1	17,8	19,5	21,2	22,8	24,5	26,2	27,9	29,6	31,2	32,9	34,6	36,3		
600	kg	17,1	18,9	20,6	22,4	24,2	26,0	27,8	29,6	31,3	33,1	34,9	36,7	38,5		

CU-LT-1S + BFL

Hn\Wn [mm]		200	250	300	350	400	450	500	550	600	650	700	750	800		
100	kg	7,3	8,0	8,7	9,4	10,1	10,9	11,6	12,3	13,0	13,7	14,4	15,1	15,9		
150	kg	8,2	9,0	9,8	10,7	11,5	12,3	13,1	14,0	14,8	15,6	16,4	17,3	18,1		
200	kg	9,1	10,1	11,0	11,9	12,9	13,8	14,7	15,6	16,6	17,5	18,4	19,4	20,3		
250	kg	10,1	11,1	12,1	13,2	14,2	15,2	16,3	17,3	18,4	19,4	20,4	21,5	22,5		
300	kg	11,0	12,1	13,3	14,4	15,6	16,7	17,8	19,0	20,1	21,3	22,4	23,6	24,7		
350	kg	11,9	13,2	14,4	15,7	16,9	18,2	19,4	20,7	21,9	23,2	24,4	25,7	26,9		
400	kg	12,9	14,2	15,6	16,9	18,3	19,6	21,0	22,3	23,7	25,1	26,4	27,8	29,1		
450	kg	13,8	15,2	16,7	18,2	19,6	21,1	22,6	24,0	25,5	26,9	28,4	29,9	31,3		
500	kg	14,7	16,3	17,8	19,4	21,0	22,6	24,1	25,7	27,3	28,8	30,4	32,0	33,5		
550	kg	15,6	17,3	19,0	20,7	22,3	24,0	25,7	27,4	29,1	30,7	32,4	34,1	35,8		
600	kg	16,6	18,4	20,1	21,9	23,7	25,5	27,3	29,1	30,8	32,6	34,4	36,2	38,0		

CU-LT-1S + BFLT

Hn\Wn [mm]		200	250	300	350	400	450	500	550	600	650	700	750	800		
100	kg	7,4	8,1	8,8	9,5	10,2	11,0	11,7	12,4	13,1	13,8	14,5	15,2	16,0		
150	kg	8,3	9,1	9,9	10,8	11,6	12,4	13,2	14,1	14,9	15,7	16,5	17,4	18,2		
200	kg	9,2	10,2	11,1	12,0	13,0	13,9	14,8	15,7	16,7	17,6	18,5	19,5	20,4		
250	kg	10,2	11,2	12,2	13,3	14,3	15,3	16,4	17,4	18,5	19,5	20,5	21,6	22,6		
300	kg	11,1	12,2	13,4	14,5	15,7	16,8	17,9	19,1	20,2	21,4	22,5	23,7	24,8		
350	kg	12,0	13,3	14,5	15,8	17,0	18,3	19,5	20,8	22,0	23,3	24,5	25,8	27,0		
400	kg	13,0	14,3	15,7	17,0	18,4	19,7	21,1	22,4	23,8	25,2	26,5	27,9	29,2		
450	kg	13,9	15,3	16,8	18,3	19,7	21,2	22,7	24,1	25,6	27,0	28,5	30,0	31,4		
500	kg	14,8	16,4	17,9	19,5	21,1	22,7	24,2	25,8	27,4	28,9	30,5	32,1	33,6		
550	kg	15,7	17,4	19,1	20,8	22,4	24,1	25,8	27,5	29,2	30,8	32,5	34,2	35,9		
600	kg	16,7	18,5	20,2	22,0	23,8	25,6	27,4	29,2	30,9	32,7	34,5	36,3	38,1		

Selection data

$$\Delta p \text{ [Pa]} = \zeta \cdot v^2 \cdot 0,6$$

Hn\Wn [mm]		200	250	300	350	400	450	500	550	600	650	700	750	800		
100	ζ [-]	1,69	1,65	1,62	1,60	1,59	1,58	1,57	1,56	1,55	1,55	1,54	1,54	1,54		
150	ζ [-]	0,98	0,93	0,89	0,87	0,85	0,83	0,82	0,81	0,80	0,80	0,79	0,79	0,78		
200	ζ [-]	0,69	0,63	0,60	0,57	0,55	0,54	0,52	0,51	0,51	0,50	0,49	0,49	0,49		
250	ζ [-]	0,54	0,48	0,44	0,42	0,40	0,39	0,37	0,37	0,36	0,35	0,35	0,34	0,34		
300	ζ [-]	0,45	0,39	0,35	0,33	0,31	0,30	0,29	0,28	0,27	0,26	0,26	0,26	0,25		
350	ζ [-]	0,39	0,33	0,30	0,27	0,25	0,24	0,23	0,22	0,22	0,21	0,21	0,20	0,20		
400	ζ [-]	0,34	0,29	0,26	0,23	0,22	0,20	0,19	0,18	0,18	0,17	0,17	0,16	0,16		
450	ζ [-]	0,31	0,26	0,23	0,20	0,19	0,17	0,16	0,16	0,15	0,15	0,14	0,14	0,13		
500	ζ [-]	0,29	0,24	0,20	0,18	0,17	0,15	0,14	0,14	0,13	0,13	0,12	0,12	0,12		
550	ζ [-]	0,27	0,22	0,19	0,16	0,15	0,14	0,13	0,12	0,12	0,11	0,11	0,10	0,10		
600	ζ [-]	0,25	0,20	0,17	0,15	0,14	0,12	0,12	0,11	0,10	0,10	0,10	0,09	0,09		

Example

Data

Hn = 350 mm, Bn = 400 mm, v = 5 m/s

Calculation

$\Delta p = 0.25 * (5 \text{ m/s})^2 * 0.6 = 3.75 \text{ Pa}$

CU-LT-1S - A-weighted sound power level Lwa in the room

Hn\Wn [mm]	200	250	300	350	400	450	500	550	600	650	700	750	800		
100	Sn [m ²]	0,0099	0,0127	0,0154	0,0182	0,0209	0,0237	0,0264	0,0292	0,0319	0,0347	0,0374	0,0402	0,0429	
	Sn [%]	54,29	55,15	55,72	56,13	56,43	56,67	56,85	57,00	57,13	57,24	57,33	57,41	57,48	
	Q [m ³ /h]	690	860	1.030	1.200	1.360	1.530	1.700	1.870	2.030	2.200	2.370	2.540	2.700	45 dB
	Δp [Pa]	93,34	90,41	88,50	87,16	84,91	84,29	83,80	83,41	82,26	82,05	81,86	81,70	80,97	
	Q [m ³ /h]	560	700	840	970	1.110	1.250	1.380	1.520	1.650	1.790	1.930	2.060	2.200	40 dB
	Δp [Pa]	61,48	59,90	58,86	56,95	56,56	56,26	55,22	55,11	54,35	54,32	54,29	53,74	53,75	
	Q [m ³ /h]	460	570	680	790	900	1.010	1.120	1.230	1.350	1.460	1.570	1.680	1.790	35 dB
	Δp [Pa]	41,49	39,71	38,57	37,77	37,19	36,73	36,38	36,08	36,38	36,13	35,92	35,74	35,59	
	Q [m ³ /h]	370	460	550	640	730	820	910	1.000	1.090	1.180	1.270	1.360	1.450	30 dB
	Δp [Pa]	26,84	25,87	25,23	24,79	24,46	24,21	24,01	23,85	23,72	23,60	23,51	23,42	23,35	
	Q [m ³ /h]	310	380	450	520	600	670	740	820	890	960	1.040	1.110	1.180	25 dB
	Δp [Pa]	18,84	17,65	16,89	16,37	16,53	16,16	15,88	16,04	15,81	15,62	15,76	15,60	15,46	
150	Sn [m ²]	0,0189	0,0242	0,0294	0,0347	0,0399	0,0452	0,0504	0,0557	0,0609	0,0662	0,0714	0,0767	0,0819	
	Sn [%]	67,65	68,73	69,44	69,95	70,33	70,62	70,85	71,04	71,20	71,33	71,45	71,54	71,63	
	Q [m ³ /h]	940	1.170	1.390	1.610	1.840	2.060	2.290	2.510	2.730	2.960	3.180	3.410	3.630	45 dB
	Δp [Pa]	44,54	41,91	39,31	37,88	37,01	35,79	35,39	34,71	34,08	34,14	33,55	33,60	33,04	
	Q [m ³ /h]	770	950	1.130	1.310	1.490	1.680	1.860	2.040	2.220	2.400	2.590	2.770	2.950	40 dB
	Δp [Pa]	30,00	27,56	26,02	24,96	24,18	23,87	23,37	22,97	22,64	22,36	22,30	22,08	21,90	
	Q [m ³ /h]	620	770	920	1.070	1.220	1.360	1.510	1.660	1.810	1.960	2.100	2.250	2.400	35 dB
	Δp [Pa]	19,45	18,11	17,25	16,65	16,21	15,64	15,40	15,21	15,05	14,91	14,66	14,57	14,49	
	Q [m ³ /h]	510	630	750	870	990	1.110	1.230	1.350	1.470	1.590	1.710	1.830	1.950	30 dB
	Δp [Pa]	13,16	12,12	11,46	11,01	10,67	10,42	10,22	10,06	9,93	9,81	9,72	9,64	9,57	
	Q [m ³ /h]	410	510	610	710	810	900	1.000	1.100	1.200	1.290	1.390	1.490	1.590	25 dB
	Δp [Pa]	8,51	7,94	7,58	7,33	7,15	6,85	6,76	6,68	6,61	6,46	6,42	6,39	6,36	
200	Sn [m ²]	0,0279	0,0357	0,0434	0,0512	0,0589	0,0667	0,0744	0,0822	0,0899	0,0977	0,1054	0,1132	0,1209	
	Sn [%]	74,13	75,31	76,09	76,65	77,06	77,38	77,63	77,84	78,01	78,16	78,29	78,39	78,49	
	Q [m ³ /h]	1.190	1.470	1.750	2.030	2.310	2.590	2.860	3.140	3.420	3.700	3.980	4.260	4.530	45 dB
	Δp [Pa]	28,38	25,37	23,49	22,20	21,26	20,55	19,85	19,42	19,06	18,77	18,51	18,29	18,02	
	Q [m ³ /h]	970	1.200	1.420	1.650	1.880	2.100	2.330	2.550	2.780	3.010	3.230	3.460	3.690	40 dB
	Δp [Pa]	18,85	16,91	15,46	14,67	14,08	13,51	13,18	12,81	12,60	12,42	12,19	12,07	11,96	
	Q [m ³ /h]	790	970	1.160	1.340	1.530	1.710	1.890	2.080	2.260	2.450	2.630	2.810	3.000	35 dB
	Δp [Pa]	12,51	11,05	10,32	9,67	9,33	8,96	8,67	8,52	8,32	8,23	8,08	7,96	7,90	
	Q [m ³ /h]	640	790	940	1.090	1.240	1.390	1.540	1.690	1.840	1.990	2.140	2.290	2.440	30 dB
	Δp [Pa]	8,21	7,33	6,78	6,40	6,13	5,92	5,76	5,63	5,52	5,43	5,35	5,29	5,23	
	Q [m ³ /h]	520	640	770	890	1.010	1.130	1.250	1.370	1.500	1.620	1.740	1.860	1.980	25 dB
	Δp [Pa]	5,42	4,81	4,55	4,27	4,06	3,91	3,79	3,70	3,67	3,60	3,54	3,49	3,44	

Hn\Wn [mm]	200	250	300	350	400	450	500	550	600	650	700	750	800		
250	Sn [m ²]	0,0369	0,0472	0,0574	0,0677	0,0779	0,0882	0,0984	0,1087	0,1189	0,1292	0,1394	0,1497	0,1599	
	Sn [%]	77,95	79,20	80,02	80,60	81,03	81,37	81,64	81,85	82,04	82,19	82,32	82,44	82,53	
	Q [m ³ /h]	1.440	1.770	2.100	2.440	2.770	3.100	3.430	3.760	4.090	4.420	4.750	5.090	5.420	45 dB
	Δp [Pa]	20,74	17,89	16,14	15,08	14,21	13,56	13,05	12,64	12,31	12,03	11,80	11,64	11,46	
	Q [m ³ /h]	1.170	1.440	1.710	1.980	2.250	2.520	2.790	3.060	3.330	3.600	3.870	4.130	4.400	40 dB
	Δp [Pa]	13,69	11,84	10,70	9,93	9,38	8,96	8,63	8,37	8,16	7,98	7,83	7,66	7,55	
	Q [m ³ /h]	950	1.170	1.390	1.610	1.830	2.050	2.270	2.490	2.710	2.920	3.140	3.360	3.580	35 dB
	Δp [Pa]	9,03	7,82	7,07	6,57	6,20	5,93	5,71	5,54	5,40	5,25	5,15	5,07	5,00	
	Q [m ³ /h]	780	950	1.130	1.310	1.490	1.670	1.840	2.020	2.200	2.380	2.560	2.730	2.910	30 dB
	Δp [Pa]	6,08	5,15	4,67	4,35	4,11	3,93	3,75	3,65	3,56	3,49	3,43	3,35	3,30	
	Q [m ³ /h]	630	780	920	1.070	1.210	1.360	1.500	1.640	1.790	1.930	2.080	2.220	2.370	25 dB
	Δp [Pa]	3,97	3,47	3,10	2,90	2,71	2,61	2,50	2,40	2,36	2,29	2,26	2,21	2,19	
300	Sn [m ²]	0,0459	0,0587	0,0714	0,0842	0,0969	0,1097	0,1224	0,1352	0,1479	0,1607	0,1734	0,1862	0,1989	
	Sn [%]	80,48	81,76	82,60	83,20	83,65	84,00	84,28	84,50	84,69	84,85	84,99	85,10	85,21	
	Q [m ³ /h]	1.533	1.954	2.377	2.802	3.227	3.653	4.080	4.507	4.934	5.361	5.788	6.216	6.644	45 dB
	Δp [Pa]	13,50	12,30	11,50	10,90	10,40	10,10	9,80	9,60	9,40	9,30	9,10	9,00	8,90	
	Q [m ³ /h]	1.267	1.616	1.966	2.317	2.668	3.020	3.373	3.726	4.079	4.432	4.786	5.139	5.493	40 dB
	Δp [Pa]	9,30	8,40	7,80	7,40	7,10	6,90	6,70	6,60	6,40	6,30	6,20	6,20	6,10	
	Q [m ³ /h]	1.048	1.336	1.625	1.915	2.206	2.497	2.789	3.080	3.372	3.664	3.956	4.249	4.541	35 dB
	Δp [Pa]	6,30	5,70	5,40	5,10	4,90	4,70	4,60	4,50	4,40	4,30	4,30	4,20	4,20	
	Q [m ³ /h]	866	1.104	1.343	1.583	1.824	2.065	2.305	2.547	2.788	3.029	3.271	3.513	3.754	30 dB
	Δp [Pa]	4,30	3,90	3,70	3,50	3,30	3,20	3,10	3,10	3,00	3,00	2,90	2,90	2,90	
	Q [m ³ /h]	716	913	1.111	1.309	1.508	1.707	1.906	2.105	2.305	2.505	2.704	2.904	3.104	25 dB
	Δp [Pa]	3,00	2,70	2,50	2,40	2,30	2,20	2,10	2,10	2,10	2,00	2,00	2,00	1,90	
350	Sn [m ²]	0,0549	0,0702	0,0854	0,1007	0,1159	0,1312	0,1464	0,1617	0,1769	0,1922	0,2074	0,2227	0,2379	
	Sn [%]	82,26	83,58	84,44	85,05	85,51	85,87	86,15	86,38	86,57	86,74	86,87	86,99	87,10	
	Q [m ³ /h]	1.826	2.334	2.844	3.356	3.870	4.384	4.900	5.416	5.932	6.449	6.966	7.484	8.001	45 dB
	Δp [Pa]	12,20	10,90	10,00	9,40	9,00	8,70	8,40	8,20	8,00	7,80	7,70	7,60	7,50	
	Q [m ³ /h]	1.510	1.929	2.351	2.775	3.199	3.625	4.051	4.478	4.905	5.332	5.759	6.187	6.615	40 dB
	Δp [Pa]	8,30	7,50	6,90	6,50	6,20	5,90	5,70	5,60	5,40	5,30	5,20	5,20	5,10	
	Q [m ³ /h]	1.248	1.595	1.944	2.294	2.645	2.997	3.349	3.702	4.055	4.408	4.762	5.115	5.469	35 dB
	Δp [Pa]	5,70	5,10	4,70	4,40	4,20	4,00	3,90	3,80	3,70	3,70	3,60	3,50	3,50	
	Q [m ³ /h]	1.032	1.319	1.607	1.897	2.187	2.478	2.769	3.061	3.352	3.644	3.937	4.229	4.521	30 dB
	Δp [Pa]	3,90	3,50	3,20	3,00	2,90	2,80	2,70	2,60	2,50	2,50	2,50	2,40	2,40	
	Q [m ³ /h]	853	1.090	1.329	1.568	1.808	2.048	2.289	2.530	2.772	3.013	3.255	3.496	3.738	25 dB
	Δp [Pa]	2,70	2,40	2,20	2,10	2,00	1,90	1,80	1,80	1,70	1,70	1,70	1,70	1,60	

Hn\Wn [mm]	200	250	300	350	400	450	500	550	600	650	700	750	800		
400	Sn [m ²]	0,0639	0,0817	0,0994	0,1172	0,1349	0,1527	0,1704	0,1882	0,2059	0,2237	0,2414	0,2592	0,2769	
	Sn [%]	83,60	84,93	85,81	86,43	86,90	87,26	87,55	87,78	87,98	88,14	88,28	88,41	88,51	
	Q [m ³ /h]	2.122	2.717	3.316	3.918	4.522	5.127	5.734	6.341	6.950	7.558	8.168	8.777	9.387	45 dB
	Δp [Pa]	11,20	9,90	9,00	8,40	8,00	7,60	7,30	7,10	6,90	6,80	6,60	6,50	6,40	
	Q [m ³ /h]	1.754	2.246	2.741	3.239	3.738	4.239	4.740	5.243	5.746	6.249	6.753	7.256	7.761	40 dB
	Δp [Pa]	7,70	6,80	6,20	5,70	5,40	5,20	5,00	4,90	4,70	4,60	4,50	4,40	4,40	
	Q [m ³ /h]	1.450	1.857	2.266	2.678	3.091	3.505	3.919	4.334	4.750	5.166	5.583	5.999	6.416	35 dB
	Δp [Pa]	5,20	4,60	4,20	3,90	3,70	3,60	3,40	3,30	3,20	3,20	3,10	3,00	3,00	
	Q [m ³ /h]	1.199	1.535	1.874	2.214	2.555	2.897	3.240	3.583	3.927	4.271	4.615	4.960	5.305	30 dB
	Δp [Pa]	3,60	3,20	2,90	2,70	2,50	2,40	2,30	2,30	2,20	2,20	2,10	2,10	2,00	
450	Q [m ³ /h]	991	1.269	1.549	1.830	2.113	2.395	2.679	2.963	3.247	3.531	3.816	4.101	4.386	25 dB
	Δp [Pa]	2,40	2,20	2,00	1,80	1,70	1,70	1,60	1,50	1,50	1,50	1,40	1,40	1,40	
	Sn [m ²]	0,0729	0,0932	0,1134	0,1337	0,1539	0,1742	0,1944	0,2147	0,2349	0,2552	0,2754	0,2957	0,3159	
	Sn [%]	84,63	85,98	86,87	87,50	87,98	88,34	88,63	88,87	89,07	89,23	89,38	89,50	89,61	
	Q [m ³ /h]	2.420	3.103	3.792	4.485	5.181	5.880	6.579	7.280	7.982	8.685	9.389	10.093	10.797	45 dB
	Δp [Pa]	10,50	9,10	8,20	7,60	7,20	6,80	6,50	6,30	6,10	6,00	5,80	5,70	5,60	
	Q [m ³ /h]	2.000	2.565	3.135	3.708	4.284	4.861	5.439	6.019	6.599	7.180	7.762	8.344	8.926	40 dB
	Δp [Pa]	7,10	6,20	5,60	5,20	4,90	4,70	4,50	4,30	4,20	4,10	4,00	3,90	3,80	
	Q [m ³ /h]	1.654	2.121	2.592	3.066	3.542	4.019	4.497	4.976	5.456	5.936	6.417	6.898	7.380	35 dB
	Δp [Pa]	4,90	4,30	3,80	3,60	3,30	3,20	3,00	2,90	2,90	2,80	2,70	2,70	2,60	
500	Q [m ³ /h]	1.367	1.753	2.143	2.535	2.928	3.322	3.718	4.114	4.511	4.908	5.305	5.703	6.101	30 dB
	Δp [Pa]	3,30	2,90	2,60	2,40	2,30	2,20	2,10	2,00	2,00	1,90	1,90	1,80	1,80	
	Q [m ³ /h]	1.130	1.450	1.772	2.095	2.421	2.747	3.074	3.401	3.729	4.058	4.386	4.715	5.044	25 dB
	Δp [Pa]	2,30	2,00	1,80	1,70	1,60	1,50	1,40	1,40	1,30	1,30	1,30	1,20	1,20	
	Sn [m ²]	0,0819	0,1047	0,1274	0,1502	0,1729	0,1957	0,2184	0,2412	0,2639	0,2867	0,3094	0,3322	0,3549	
	Sn [%]	85,46	86,82	87,72	88,36	88,83	89,20	89,49	89,73	89,93	90,10	90,25	90,37	90,48	
	Q [m ³ /h]	2.718	3.491	4.272	5.058	5.847	6.640	7.434	8.231	9.028	9.827	10.627	11.427	12.228	45 dB
	Δp [Pa]	9,90	8,50	7,60	7,00	6,50	6,20	5,90	5,70	5,50	5,30	5,20	5,10	5,00	
	Q [m ³ /h]	2.247	2.886	3.532	4.181	4.834	5.489	6.146	6.805	7.464	8.124	8.786	9.447	10.109	40 dB
	Δp [Pa]	6,70	5,80	5,20	4,80	4,50	4,20	4,00	3,90	3,80	3,60	3,60	3,50	3,40	
500	Q [m ³ /h]	1.858	2.386	2.920	3.457	3.997	4.538	5.082	5.626	6.171	6.717	7.263	7.811	8.358	35 dB
	Δp [Pa]	4,60	4,00	3,60	3,30	3,10	2,90	2,80	2,70	2,60	2,50	2,40	2,40	2,30	
	Q [m ³ /h]	1.536	1.973	2.414	2.858	3.304	3.752	4.201	4.651	5.102	5.553	6.005	6.457	6.910	30 dB
	Δp [Pa]	3,10	2,70	2,40	2,20	2,10	2,00	1,90	1,80	1,80	1,70	1,70	1,60	1,60	
	Q [m ³ /h]	1.270	1.631	1.996	2.363	2.732	3.102	3.473	3.845	4.218	4.591	4.965	5.339	5.713	25 dB
	Δp [Pa]	2,20	1,90	1,70	1,50	1,40	1,30	1,30	1,20	1,20	1,20	1,10	1,10	1,10	

Hn\Wn [mm]	200	250	300	350	400	450	500	550	600	650	700	750	800		
550	Sn [m ²]	0,0909	0,1162	0,1414	0,1667	0,1919	0,2172	0,2424	0,2677	0,2929	0,3182	0,3434	0,3687	0,3939	
	Sn [%]	86,13	87,50	88,41	89,05	89,53	89,90	90,20	90,44	90,64	90,81	90,96	91,08	91,19	
	Q [m ³ /h]	3.018	3.882	4.755	5.634	6.519	7.407	8.298	9.191	10.086	10.982	11.879	12.778	13.677	45 dB
	Δp [Pa]	9,40	8,00	7,10	6,50	6,00	5,70	5,40	5,20	5,00	4,80	4,70	4,60	4,50	
	Q [m ³ /h]	2.495	3.209	3.931	4.658	5.389	6.123	6.860	7.598	8.338	9.079	9.821	10.564	11.307	40 dB
	Δp [Pa]	6,40	5,50	4,90	4,40	4,10	3,90	3,70	3,50	3,40	3,30	3,20	3,10	3,10	
	Q [m ³ /h]	2.063	2.653	3.250	3.851	4.456	5.063	5.672	6.282	6.894	7.506	8.120	8.734	9.348	35 dB
	Δp [Pa]	4,40	3,70	3,30	3,00	2,80	2,70	2,50	2,40	2,30	2,30	2,20	2,10	2,10	
	Q [m ³ /h]	1.706	2.194	2.687	3.184	3.684	4.186	4.689	5.194	5.699	6.206	6.713	7.221	7.729	30 dB
	Δp [Pa]	3,00	2,60	2,30	2,10	1,90	1,80	1,70	1,70	1,60	1,50	1,50	1,50	1,40	
	Q [m ³ /h]	1.410	1.813	2.221	2.632	3.045	3.460	3.877	4.294	4.712	5.131	5.550	5.970	6.390	25 dB
	Δp [Pa]	2,00	1,70	1,60	1,40	1,30	1,20	1,20	1,10	1,10	1,10	1,00	1,00	1,00	
600	Sn [m ²]	0,0999	0,1277	0,1554	0,1832	0,2109	0,2387	0,2664	0,2942	0,3219	0,3497	0,3774	0,4052	0,4329	
	Sn [%]	86,69	88,07	88,99	89,63	90,11	90,49	90,79	91,03	91,23	91,40	91,55	91,68	91,79	
	Q [m ³ /h]	3.319	4.274	5.240	6.214	7.194	8.179	9.168	10.159	11.153	12.148	13.145	14.143	15.142	45 dB
	Δp [Pa]	9,00	7,60	6,70	6,10	5,60	5,30	5,00	4,80	4,60	4,40	4,30	4,20	4,10	
	Q [m ³ /h]	2.744	3.533	4.332	5.137	5.948	6.762	7.580	8.399	9.220	10.043	10.867	11.693	12.519	40 dB
	Δp [Pa]	6,10	5,20	4,60	4,20	3,80	3,60	3,40	3,30	3,10	3,00	2,90	2,90	2,80	
	Q [m ³ /h]	2.269	2.921	3.581	4.247	4.918	5.591	6.266	6.944	7.623	8.303	8.985	9.667	10.350	35 dB
	Δp [Pa]	4,20	3,50	3,10	2,80	2,60	2,50	2,30	2,20	2,10	2,10	2,00	2,00	1,90	
	Q [m ³ /h]	1.876	2.415	2.961	3.512	4.066	4.622	5.181	5.741	6.302	6.865	7.428	7.992	8.557	30 dB
	Δp [Pa]	2,90	2,40	2,10	1,90	1,80	1,70	1,60	1,50	1,50	1,40	1,40	1,30	1,30	
	Q [m ³ /h]	1.551	1.997	2.448	2.903	3.361	3.821	4.283	4.746	5.210	5.675	6.141	6.607	7.074	25 dB
	Δp [Pa]	2,00	1,70	1,50	1,30	1,20	1,20	1,10	1,00	1,00	1,00	0,90	0,90	0,90	

Every air flow lower than the above mentioned maximum value, will meet the listed A-weighted sound power level for the respective dimension. More information on sound power can be found in the product information on our website (documents).

Sample order

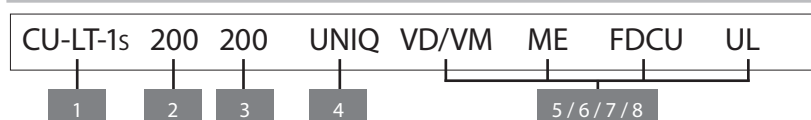

1. product
2. width
3. height
4. mechanism type
5. option: type magnet and voltage
6. option: resetting motor
7. option: uni/bipolar switches
8. option: inspection shutter

Approvals and certificates

All our dampers are submitted to a number of tests by official test institutes. Reports of these tests form the basis for the approvals of our dampers.



BCCA-0749-CPR-BC1-606-0464-15650.06-0464



18.21

NF 537
CLAPETS RÉSISTANT AU FEU
VOLETS RÉSISTANT AU FEU
www.marque-nf.com



SC0645-15



2822-UKCA-CPR-0061

The NF-label guarantees: conformity with the standard NF S 61-937 Parts 1 and 5: "Systèmes de Sécurité Incendie Dispositifs Actionnés de Sécurité"; conformity with the national decree of March 22, 2004, changed on 14 March 2011 for the classification of fire resistance; the values of the characteristics mentioned in this document. Organisme Certificateur: AFNOR Certification, 11 Rue Francis de Pressensé, F93571 La Plaine Saint-Denis Cedex; Website: <http://www.afnor.org> and <http://www.marque-nf.com>; Phone: +33 (0)1.41.62.80.00, Fax: +33 (0)1.49.17.90.00, Email: certification@afnor.org

If the product is manipulated in any other way than described in this manual, Rf-Technologies will decline any responsibility and the guarantee will expire!