

CRS60

Circular fire damper in fire-resistance class EI60S

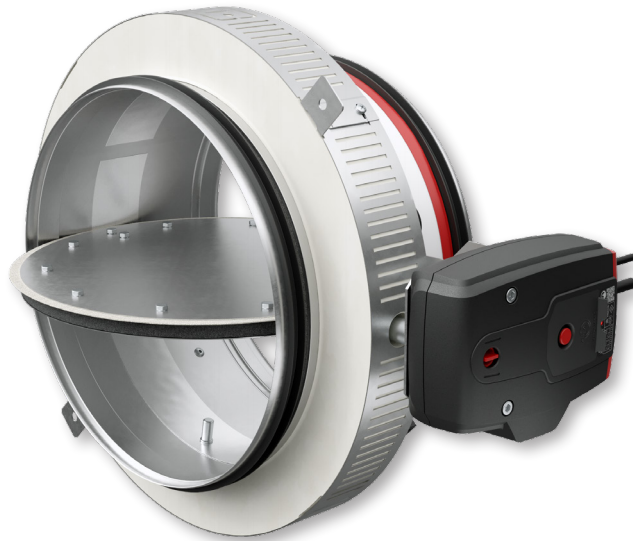

QUICK FACTS





- CRS60 is a fire damper with a circular connection Ø100-630
- EI60S provides resistance against fire and smoke for 60 minutes with increased sealing (S) against cold smoke
- For wall/floor and duct installation with various motor position of 360° angle and for minimal distance installation
- The casing is made of galvanised steel and has leakage-class C according to EN 1751
- CE approved according to product standard EN 15650
- Available with modulating motor 2-10 volt
- Can be controlled with Swegon's control and monitoring products

Table of content

Declaration of performance	4
Product presentation CRS60	5
Range and dimensions CRS60	5
Evolution - kits	6
Storage and handling	9
Installation	9
Installation at a minimal distance from another damper or from an adjacent supporting construction	10
Installation in rigid wall, sealing with acrylic sealant	11
Installation in rigid wall, sealing with stone wool	12
Installation in rigid wall, sealing with gypsum plaster or mortar	13
Installation in rigid wall, sealing with rigid stone wool boards with coating	14
Installation in flexible wall (metal stud gypsum plasterboard wall), sealing with acrylic sealant	15
Installation in flexible wall (metal stud gypsum plasterboard wall), sealing with stone wool	16
Installation in flexible wall, sealing with gypsum plaster or mortar	17
Installation in flexible wall, sealing with rigid stone wool boards with coating	18
Installation in shaftwall	19
Installation in rigid floor, sealing with acrylic sealant	20
Installation in rigid floor, sealing with stone wool	21
Installation remote from a rigid wall, sealing with acrylic sealant	22
Installation remote from a rigid wall, sealing with stone wool	23
Installation remote from a flexible wall, sealing with acrylic sealant	24
Installation remote from a flexible wall, sealing with stone wool	25
Installation remote from a shaftwall	26
Installation remote from a floor, sealing with acrylic sealant	27
Installation remote from a floor, sealing with stone wool	28
Operation and mechanisms	30
Electrical connection	36
Weights	38
Selection data	39
Sample order	39
Approvals and certificates	39

Explanation of the abbreviations and pictograms

Wn = nominal width	E.TELE = power supply magnet	Sn = free air passage
Hn = nominal height	E.ALIM = power supply motor	ζ [-] = pressure loss coefficient
Dn = nominal diameter	V = volt	Q = airflow
E = integrity	W = watt	ΔP = static pressure drop
I = thermal insulation	Auto = automatic	v = air speed in the duct
S = smoke leakage: max. 200 m ³ /(h m ²) according to EN 1366-2	Tele = remote controlled	Lwa = A-weighted sound power level
Pa = pascal	Pnom = nominal capacity	Lw oct = sound power level per octave midband
ve = vertical wall penetration	Pmax = maximum capacity	dB(A) = A-weighted decibel value
ho = horizontal floor penetration	GKB (type A) / GKF (type F): "GKB" stands for standard plasterboards (type A according to EN 520) while "GKF" plasterboards offer a higher fire resistance for a similar plate thickness (type F according to EN 520)	ΔL = correction factor
o -> i = meets the criteria from the outside (o) to the inside (i)	Cal-Sil = calcium silicate	
i <-> o = fire side not important	OP = option (delivered with the product)	
V AC = Volt alternating current	KIT = kit (delivered separately for repair or upgrade)	
V DC = Volt direct current	PG = connection flange to the duct	

	optimal acoustic performance		optimal free air passage and minimal pressure loss
	air-tightness class ATC 3 according to EN1751 (formerly C)		suitable for installation remote from the wall

DECLARATION OF PERFORMANCE

1. Unique identification code of the product-type: CRS60
2. Intended use/s: Circular fire damper to be used in conjunction with partitions to maintain fire compartments in heating, ventilating and air conditioning installations.
3. Manufacturer: RF-Technologies NV, Lange Ambachtstraat 40, B-9860 Oosterzele
4. System/s of AVCP: System 1
5. Harmonised standard / European Assessment Document: notified body / European Technical Assessment, Technical Assessment Body, notified body: certificate of constancy of performance: EN 15650:2010, BCCA with identification number 0749; BCCA-0749-CPR-BCI-606-0464-15650.20-2517
6. Declared performance according to EN 15650:2010: (Fire resistance according to EN 1366-2 and classifications according to EN 13501-3)

Essential characteristics		Performance	
Range	Type	Sealing	Installation
Ø 100-630 mm	Rigid wall	Fire resistant acrylic sealant Fire resistant acrylic sealant Fire resistant acrylic sealant Stone wool + coating with acrylic sealant Stone wool + coating with acrylic sealant Stone wool + coating with acrylic sealant Mortar / Gypsum plaster Fire resistant acrylic sealant Fire resistant acrylic sealant Stone wool + coating with acrylic sealant Stone wool + coating with acrylic sealant Fire resistant acrylic sealant	1 2 3 2 3 3 1 2 3 2 1 2 3
	Rigid floor	Aerated concrete ≥ 100 mm Aerated concrete ≥ 100 mm	1 2 3 2 3 3 1 2 3 2 1 2 3
	Flexible wall	Metal studs gypsum plasterboard Type A (EN 520) ≥ 100 mm	1 2 3 2 3 3 1 2 3 2 1 2 3
Asymmetrical flexible wall (shaftwall)		Fire resistant acrylic sealant Fire resistant acrylic sealant Stone wool + coating with acrylic sealant Stone wool + coating with acrylic sealant Mortar / Gypsum plaster Fire resistant acrylic sealant Fire resistant acrylic sealant	2 3 2 3 3 3 2

1	Type of installation: surface-mounted, 0-360° (300 Pa). Minimal distances authorised.	2	Type of installation: remote from the wall, 0-360°	3	Type of installation: surface-mounted, 0-360° (300 Pa)
---	--	---	--	---	--

Nominal activation conditions/sensitivity: Pass
Response delay (response time): closure time Pass
Operational reliability: cycling ONE - 10000 cycles; ONE-X - 10000 cycles; BELT - 10000 cycles; BFNT - 10000 cycles; BFNT-SR - 20000 cycles; BFNT-SR-20000 cycles; UNIQ/VD/VM/FDCB/ME-TA - 10000 cycles
Durability of response delay: Pass
Durability of operational reliability: Pass
Protection against corrosion according to EN 60068-2-52: Pass
Damper casing leakage according to EN 1751: ≥ class ATC3 (formerly C)

The performance of the product identified above is in conformity with the set of declared performance/s. This declaration of performance is issued, in accordance with Regulation (EU) No 305/2011, under the sole responsibility of the manufacturer identified above.

Harmonised standard
EN 15650:2010



Signed for and on behalf of the manufacturer by:
Duchan Laplace, R&D Manager

 Oosterzele, 01/02/2026

Product presentation CRS60

Circular fire damper with a fire resistance of up to 60 minutes. The damper collar and short damper tunnel guarantee quick and easy mounting, both in surface and remote mounting. The optimised design of this fire damper ensures excellent aeraulic and acoustic performance. Available in diameters 100-630 mm.

Fire dampers are installed where air ducts penetrate fire-resistant compartment walls. Their role is to restore the fire resistance grade of the penetrated wall and to prevent smoke propagation. Fire dampers are distinguished by their degree of fire resistance, by their aeraulic properties as well as by their installation ease. Rf-Technologies' fire dampers are all CE marked. They can be equipped with various types of mechanisms depending on the specific needs linked to the project or to the local regulations.

- ✓ easy to install
- ✓ optimal free air passage and minimal pressure loss
- ✓ optimal acoustic performance
- ✓ air-tightness class ATC 3 according to EN1751 (formerly C)



- suitable for surface-mount in rigid wall/floor, light wall and shaftwall (metal stud gypsum plasterboard wall)
- minimal distance allowed
- suitable for installation remote from the wall or floor
- tested according to EN 1366-2 up to 500 Pa
- maintenance-free
- for indoor use
- operating temperature: max. 50°C

1. casing in galvanised steel
2. damper blade
3. operating mechanism
4. rubber sealing ring
5. sealing ring for damper blade
6. collar
7. intumescent strip
8. fixation plate

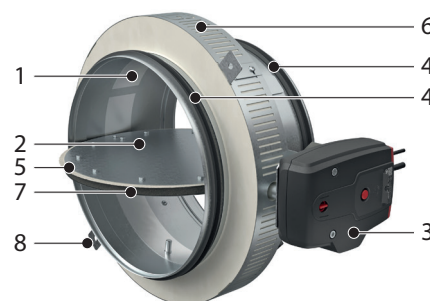

Range and dimensions CRS60

ØDn (mm)	100	125	160	200	250	315	400	500	630
----------	-----	-----	-----	-----	-----	-----	-----	-----	-----

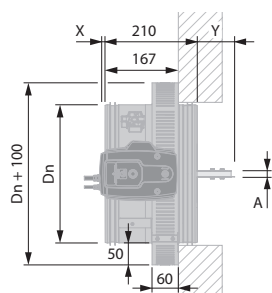







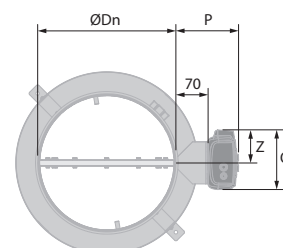

Exceeding blade: X = on the mechanism side, Y = on the wall side



ØDn (mm)	100	125	160	200	250	315	400	500	630
X	-	-	-	-	-	23	66	116	181
Y	-	-	10	30	55	88	130	180	245
A	15	15	15	15	15	15	27	27	27

	ONE	BFNT	BFLT
P	141	134.8	130
Q	136	98	80
Z	60.8	49	40



Evolution - kits

	KIT ONE T 24 FDCU L	Spring return actuator ONE 24V (with fusible link T) + unipolar beginning- and end-of-range switch
	KIT ONE T 24 FDCU ST L	Spring return actuator ONE 24V (with fusible link T) + unipolar beginning- and end-of-range switch + plug (ST)
	KIT ONE T 230 FDCU L	Spring return actuator ONE 230V (with fusible link T) + unipolar beginning- and end-of-range switch
	KIT ONE T 230 FDCU ST L	Spring return actuator ONE 230V (with fusible link T) + unipolar beginning- and end-of-range switch + plug (ST)
	KIT ONE-X 24 L	Spring return actuator ONE-X 24V (with extended fusible link T) with integrated communication module
	KIT ONE-X 230 L	Spring return actuator ONE-X 230V (with extended fusible link T) with integrated communication module
	KIT BFLT24	Spring return actuator BFL 24V with thermo-electric fuse (T)
	KIT BFLT24-ST	Spring return actuator BFL 24V with thermo-electric fuse (T) and plug (ST)

	KIT BFLT24-SR	Spring return actuator BFL 24V with thermo-electric fuse (T) and modulating function
	KIT BFLT230	Spring return actuator BFL 230V with thermo-electric fuse (T)
	KIT BFLT230-ST	Spring return actuator BFL 230V with thermo-electric fuse (T)
	KIT BFNT24	Spring return actuator BFN 24V with thermo-electric fuse (T)
	KIT BFNT24-ST	Spring return actuator BFN 24V with thermo-electric fuse (T) and plug (ST)
	KIT BFNT24-SR	Spring return actuator BFN 24V with thermo-electric fuse (T) and modulating function
	KIT BFNT230	Spring return actuator BFN 230V with thermo-electric fuse (T)
	KIT BFNT230-ST	Spring return actuator BFN 230V with thermo-electric fuse (T)



KIT SN2 BFL/BFN

Auxiliary limit switch 'open/closed'



FUS72 ONE L

Fusible link 72°C



MECT

Testbox for mechanisms 24/48 V (magnet, motor, beginning and end of range switches)



KIT UG8

The UG8 optical smoke detector is a standalone unit for duct mounting. It samples air in the ventilation duct via the venturi-tube and analyses it in the housing situated outside of the duct. The UG8 is CE-marked product, certified according to EN54-27. It can be connected directly with a fire damper: in the event of smoke detection, the UG8 shuts off the power to the fire damper actuator and closes the damper. The UG8 is fitted with LEDs showing normal operation, smoke alarm, contamination and service alarms. The status can also be checked remotely via relay outputs.

Storage and handling

As this product is a safety element, it should be stored and handled with care.

Avoid:

- any kind of impact or damage
- contact with water
- deformation of the casing

It is recommended:

- to unload in a dry area
- not to flip or roll the product to move it
- not to use the damper as a scaffold, working table, etc.
- not to store smaller dampers inside larger ones

Installation

General points

- The installation must comply with the installation manual and the classification report.
- Axis orientation: see the declaration of performance.
- Avoid obstruction of adjoining ducts.
- Product installation: always with closed damper blade.
- Verify if the blade can move freely.
- Please observe safety distances with respect to other construction elements. The operating mechanism must also remain accessible: allow for a clearance of 200 mm around the housing.
- The air tightness class will be maintained if the damper is installed according to the installation manual.
- Rf-t fire dampers are always tested in standardised constructions according to EN 1366-2. The achieved results are valid for similar supporting constructions with a fire resistance, thickness and density equal or superior to the supporting construction used during the test.
- If the wall thickness exceeds the minimum thickness specified in our installation instructions, the following conditions apply to the sealing depth:
 - For flexible walls and sandwich panel system walls, the seal must always be applied over the full depth of the wall.
 - With rigid walls, rigid floors and plaster block walls, the minimum sealing depth as indicated in our installation instructions (often equal to the minimum wall thickness) is sufficient. Apply the seal at the height of the damper blade (from the wall limit indication).
- When installing a fire damper in a flexible metal stud wall, some installation methods do not require reinforcing profiles around the wall opening from a fire protection point of view (see below). Always follow the general instructions of the manufacturer of these wall systems when building this type of wall.
- The damper must remain accessible for inspection and maintenance.
- Schedule at least 2 visual checks each year.

	TEST	
2023	<input checked="" type="checkbox"/>	<input checked="" type="checkbox"/>
2024	<input checked="" type="checkbox"/>	<input checked="" type="checkbox"/>
2025	<input checked="" type="checkbox"/>	<input type="checkbox"/>
2026	<input type="checkbox"/>	<input type="checkbox"/>
2027	<input type="checkbox"/>	<input type="checkbox"/>

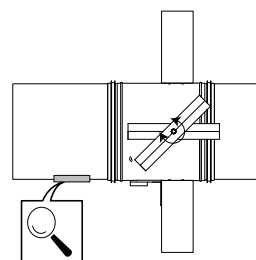

Product specific

- On one side of the fire damper, the surface-mounted collar acts as a stop for the air duct. On the other side, the stop for the duct is formed by the ends of the fixing plates and the mechanism bridge.
- It is not required to fix the duct to the fire damper with screws, but it is allowed. The screws may be inserted through the rubber sealing ring. Maximum screw length 9.5mm.
- Diameter 100 to 315 has 2 fixation plates. Diameter 400 to 630 has 4 fixation plates.

Installation at a minimal distance from another damper or from an adjacent supporting construction

1

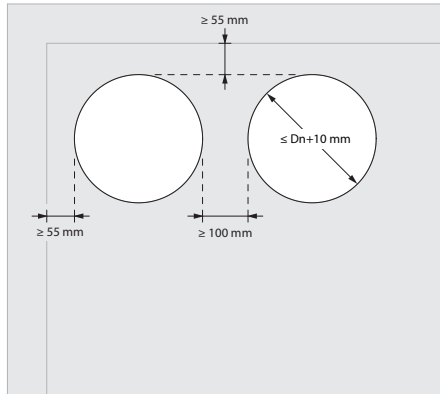

1. Principle

According to the European test standard, a fire damper must be installed at a minimum distance of 75 mm from an adjacent wall and 200 mm from another damper, unless the solution was tested at a shorter distance.

This Rf-Technologies fire damper has been successfully tested and may be installed at a shorter distance than the minimum specified by the standard in the following installation situations:

- Installation in rigid wall, sealing with acrylic sealant
- Installation in flexible wall (metal stud gypsum plasterboard wall), sealing with acrylic sealant
- Installation in rigid floor, sealing with acrylic sealant

2

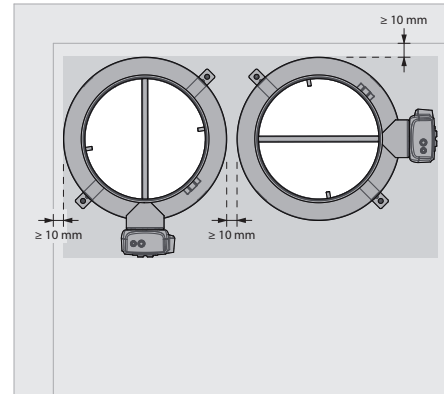

2. Restrictions

A maximum of 2 dampers may be installed next to each other at a minimum distance from wall and/or ceiling/floor.

For installation of a third fire damper (or a second pair of fire dampers), a distance of 200 mm should be respected from the first pair (to be measured from damper tunnel to damper tunnel).

Installation in rigid wall, sealing with acrylic sealant

The product was tested and approved in:

Range	Wall type	Sealing	Classification
Ø 100-630 mm	Rigid wall	Aerated concrete ≥ 100 mm	Fire resistant acrylic sealant
			El 60 (v _e i ↔ o) S - (300 Pa)

1

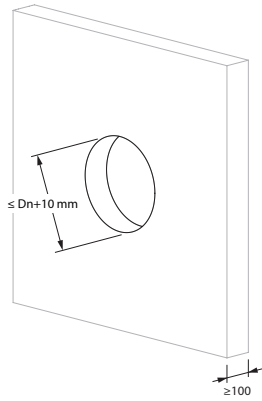

2

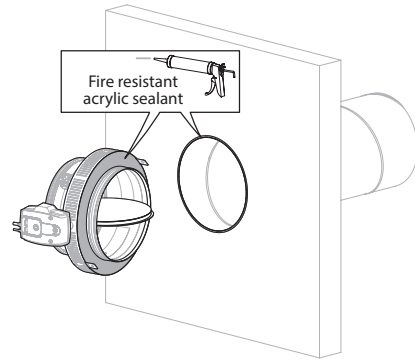

3

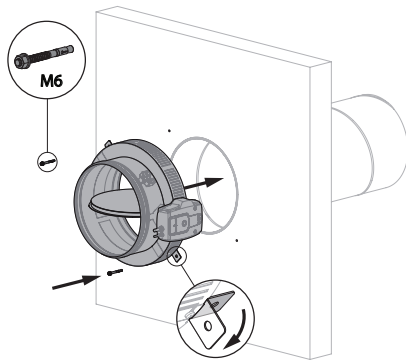

4

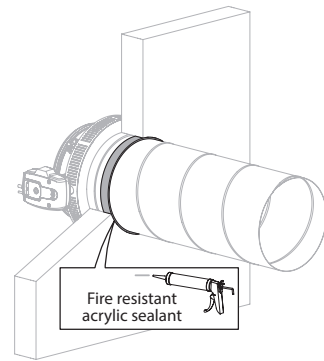

Installation in rigid wall, sealing with stone wool

The product was tested and approved in:

Range	Wall type	Sealing	Classification
Ø 100-630 mm	Rigid wall	Aerated concrete ≥ 100 mm	Stone wool + coating with acrylic sealant
			El 60 (v _e i ↔ o) S - (300 Pa)

1

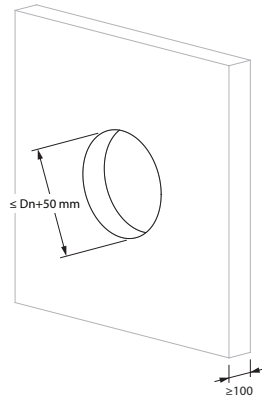

2

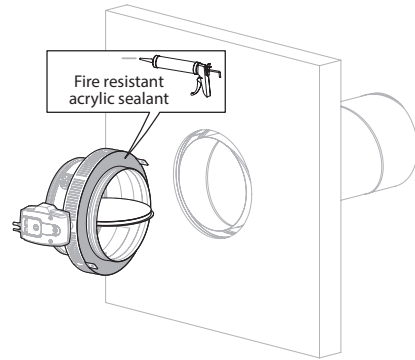

3

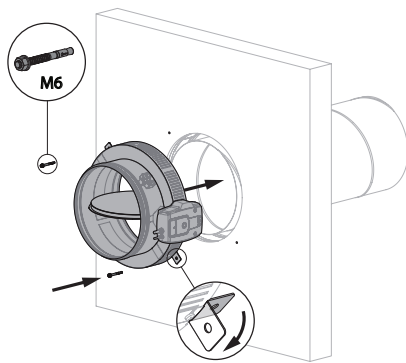

4

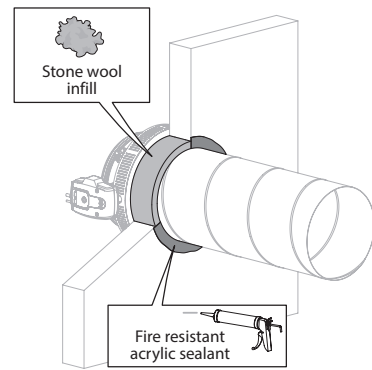

Installation in rigid wall, sealing with gypsum plaster or mortar

The product was tested and approved in:

Range	Wall type	Sealing	Classification
Ø 100-630 mm	Rigid wall	Aerated concrete ≥ 100 mm	Mortar / Gypsum plaster
			El 60 (v _e i ↔ o) S - (300 Pa)

1

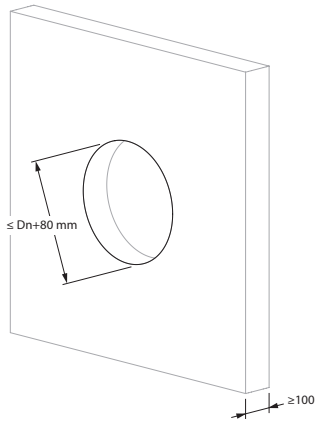

2

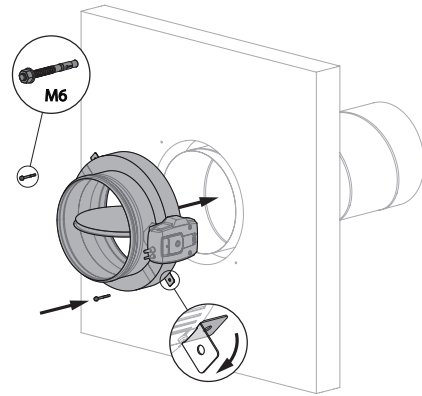

3

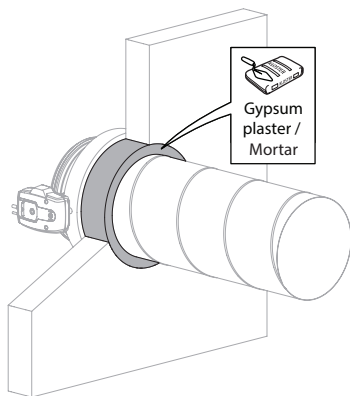

Installation in rigid wall, sealing with rigid stone wool boards with coating

The product was tested and approved in:

Range	Wall type	Sealing	Classification
Ø 100-630 mm	Rigid wall	Aerated concrete ≥ 100 mm	Stone wool + coating ≥ 140 kg/m ³
			El 60 (v _e i ↔ o) S - (300 Pa)

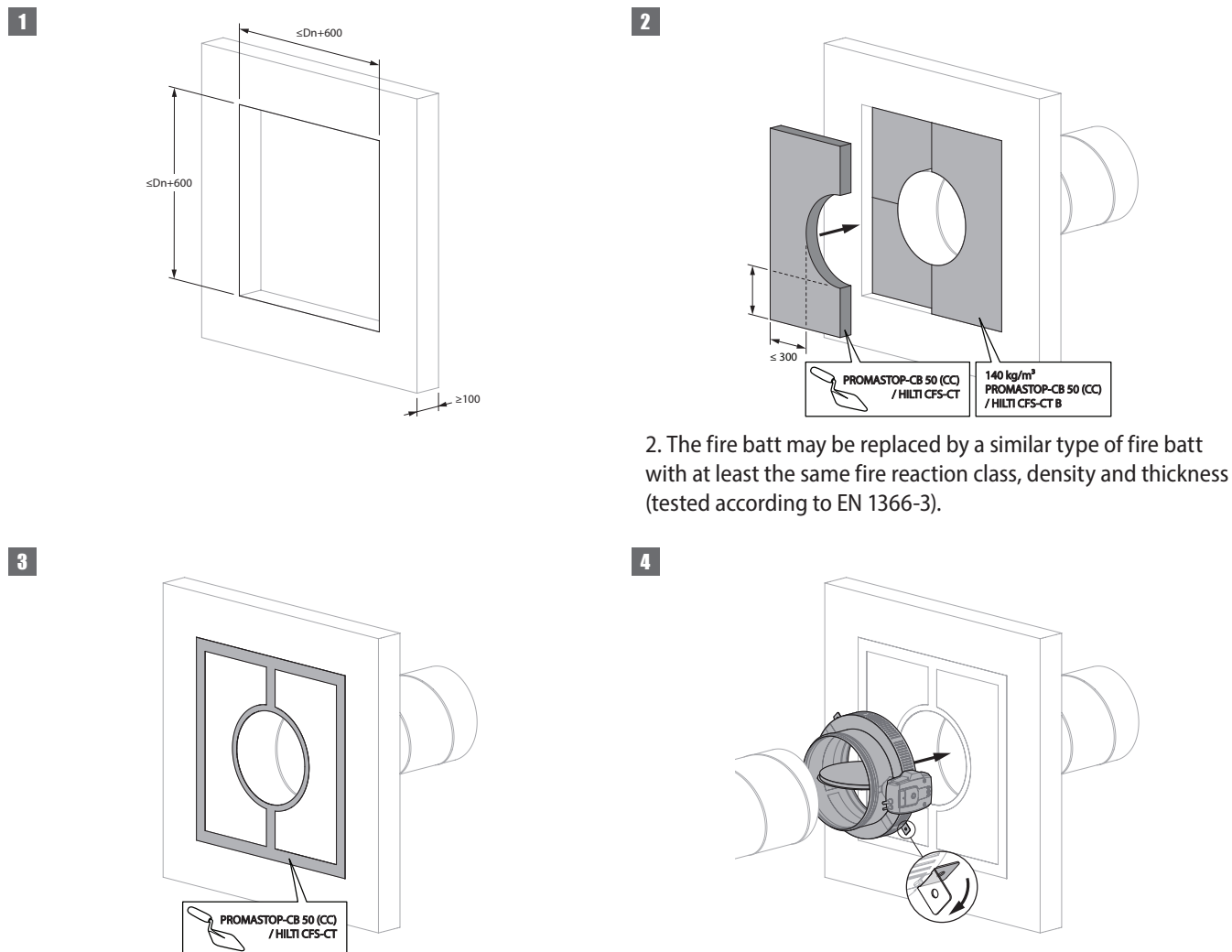

Installation in flexible wall (metal stud gypsum plasterboard wall), sealing with acrylic sealant

The product was tested and approved in:

Range	Wall type	Sealing	Classification
Ø 100-630 mm	Flexible wall	Fire resistant acrylic sealant	El 60 (v _e i ↔ o) S - (300 Pa)

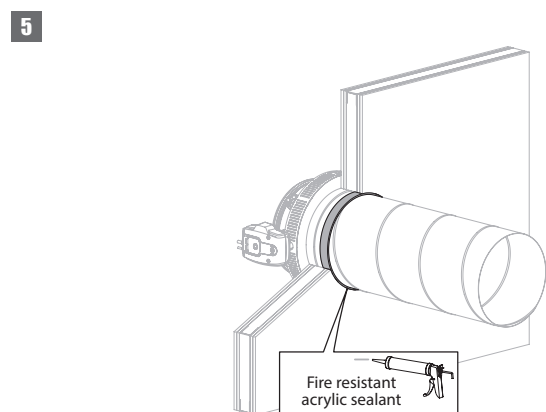
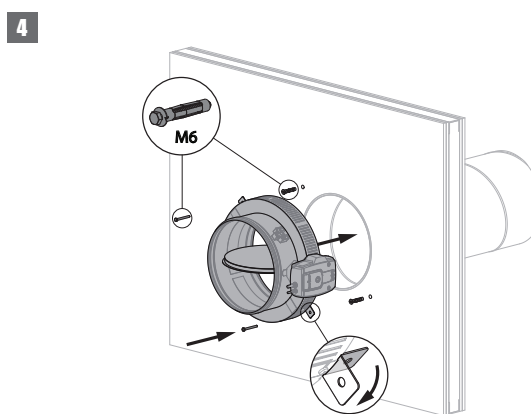
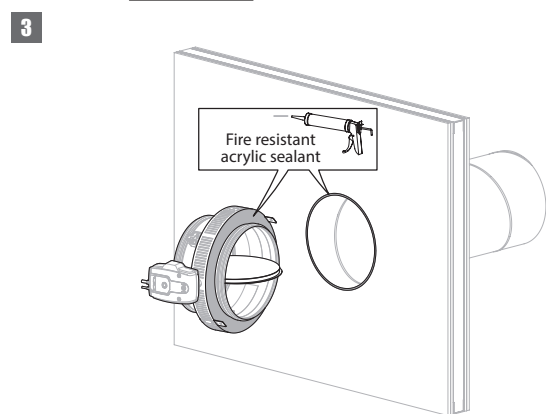
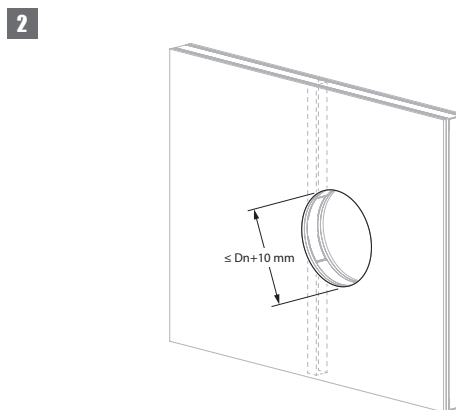
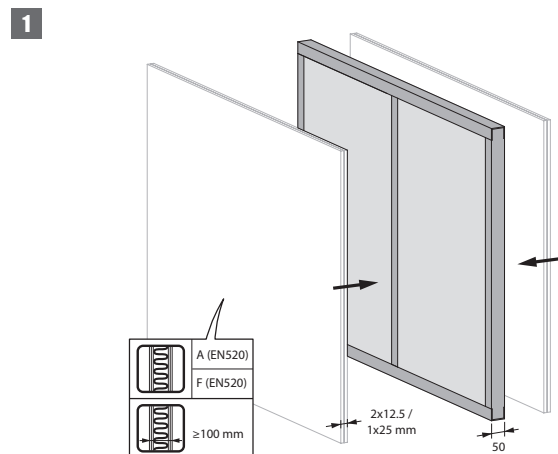

Installation in flexible wall (metal stud gypsum plasterboard wall), sealing with stone wool

The product was tested and approved in:

Range	Wall type	Sealing	Classification
Ø 100-630 mm	Flexible wall	Stone wool + coating with acrylic sealant	EI 60 (v _e i ↔ o) S - (300 Pa)

1

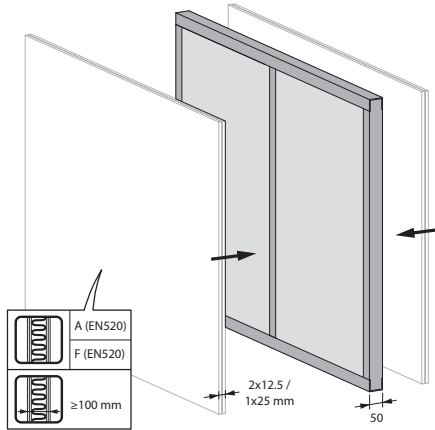

2

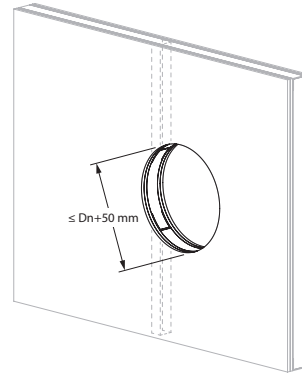

3

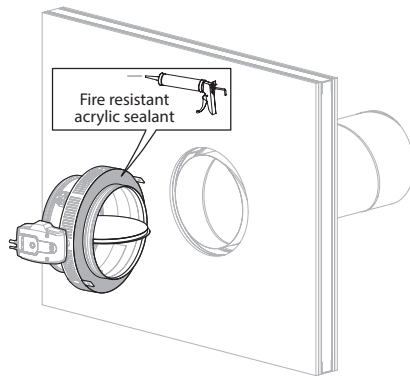

4

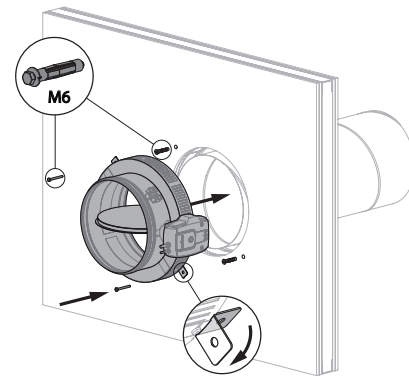

5

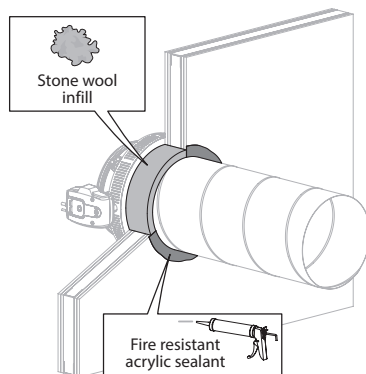

Installation in flexible wall, sealing with gypsum plaster or mortar

The product was tested and approved in:

Range	Wall type	Sealing	Classification
Ø 100-630 mm	Flexible wall	Mortar / Gypsum plaster	El 60 (v _e i ↔ o) S - (300 Pa)

1

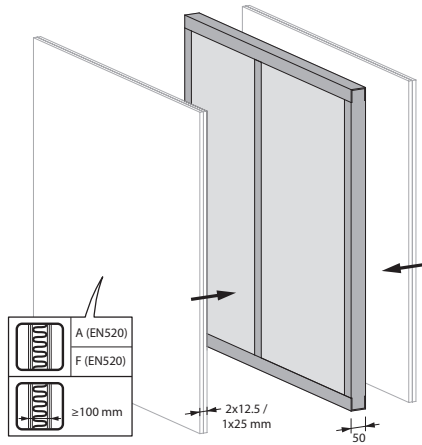

2

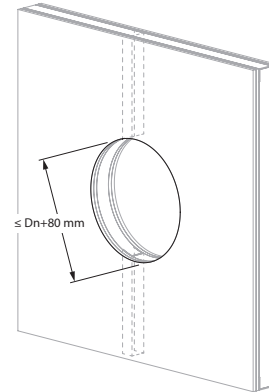

3

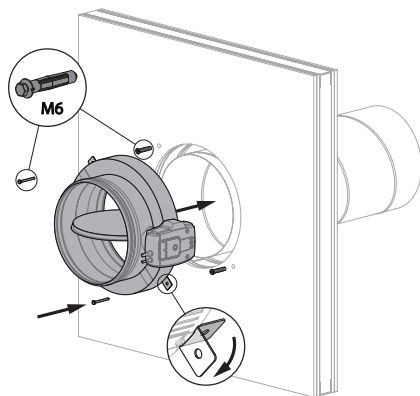

4

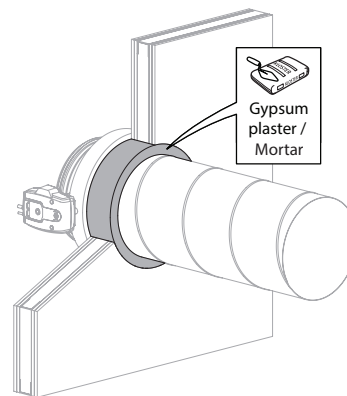

Installation in flexible wall, sealing with rigid stone wool boards with coating

The product was tested and approved in:

Range	Wall type	Sealing	Classification
Ø 100-630 mm	Flexible wall	Stone wool + coating $\geq 140 \text{ kg/m}^3$	EI 60 ($v_e i \leftrightarrow o$) S - (300 Pa)

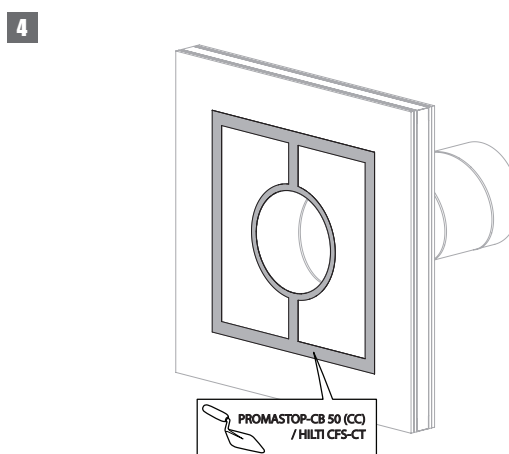
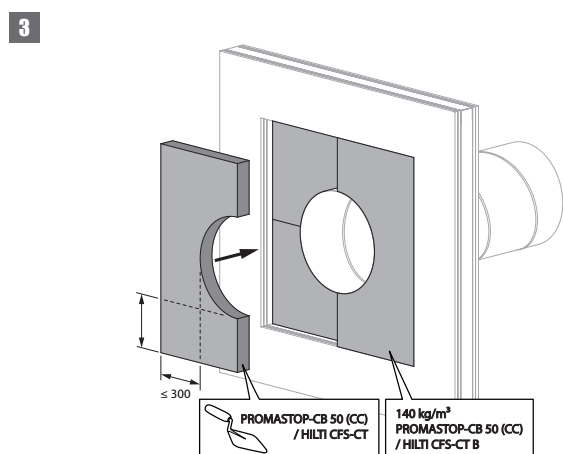
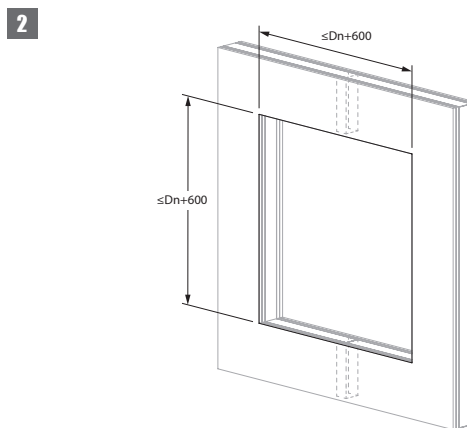
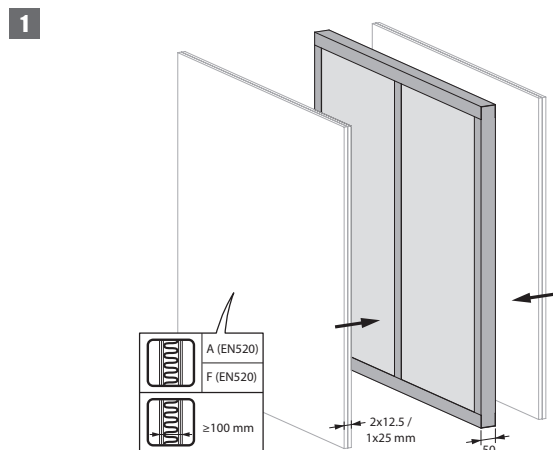

3. The fire batt may be replaced by a similar type of fire batt with at least the same fire reaction class, density and thickness (tested according to EN 1366-3).

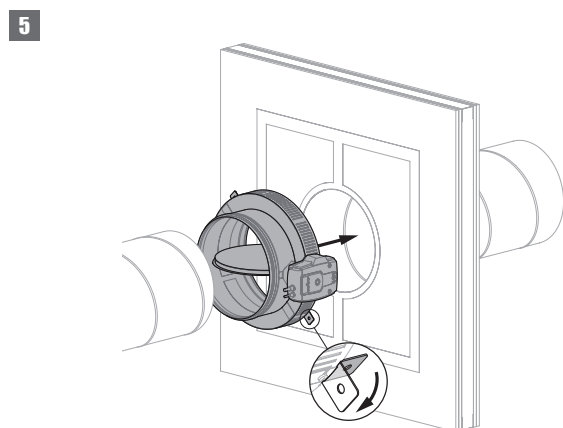

Installation in shaftwall

The product was tested and approved in:

Range	Wall type		Sealing	Classification
Ø 100-630 mm	Asymmetrical flexible wall (shaftwall)	Metal studs gypsum plasterboard Type F (EN 520) ≥ 80 mm	Fire resistant acrylic sealant	El 60 (v _e i ↔ o) S - (300 Pa)

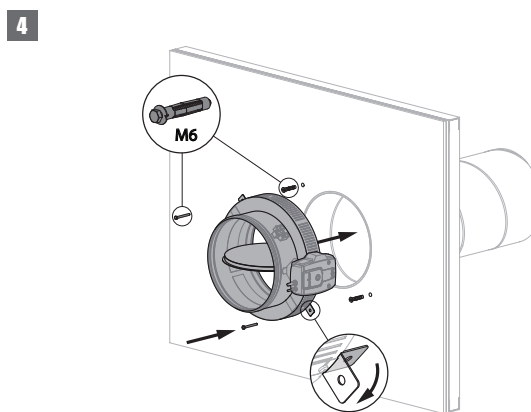
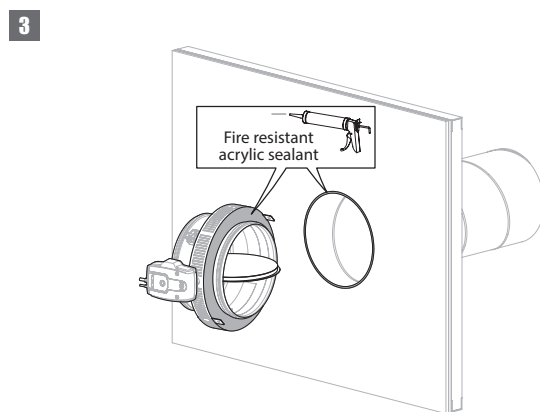
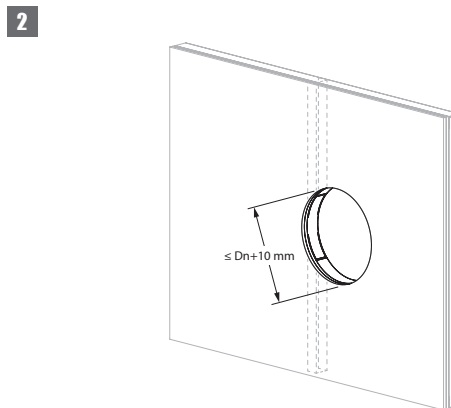
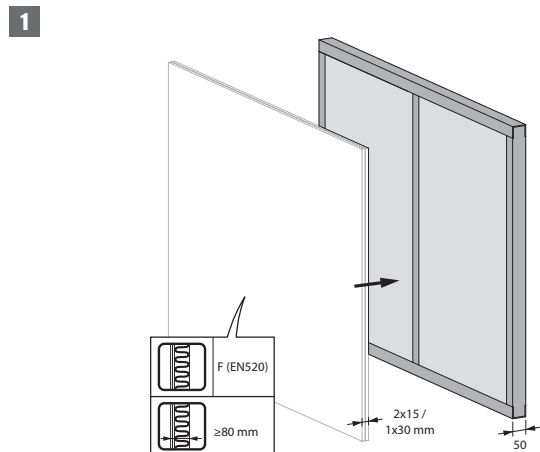

Installation in rigid floor, sealing with acrylic sealant

The product was tested and approved in:

Range	Wall type	Sealing	Classification
Ø 100-630 mm	Rigid floor	Aerated concrete ≥ 100 mm	Fire resistant acrylic sealant
			El 60 (h _o i ↔ o) S - (300 Pa)

1

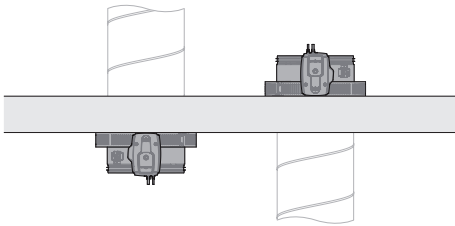

2

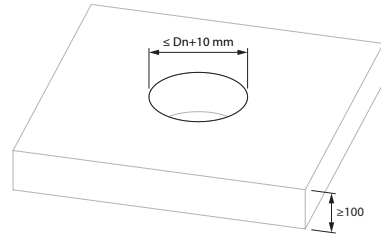

3

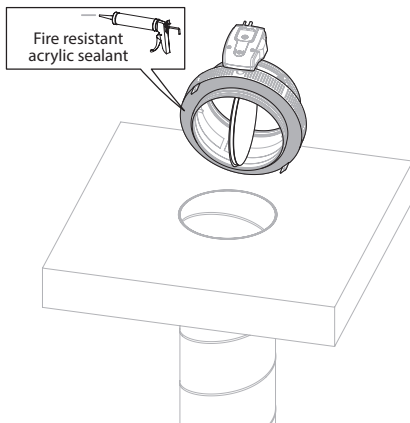

4

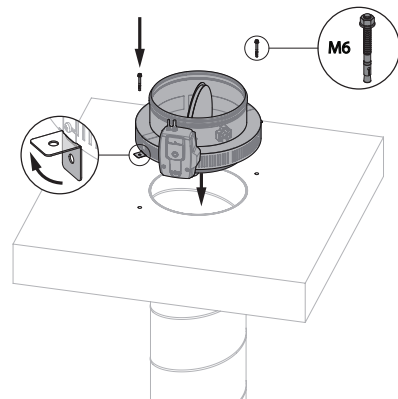

5

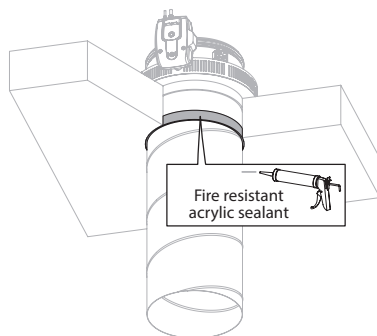

Installation in rigid floor, sealing with stone wool

The product was tested and approved in:

Range	Wall type	Sealing	Classification
Ø 100-630 mm	Rigid floor	Aerated concrete ≥ 100 mm	Stone wool + coating with acrylic sealant
			El 60 (h _o i ↔ o) S - (300 Pa)

1

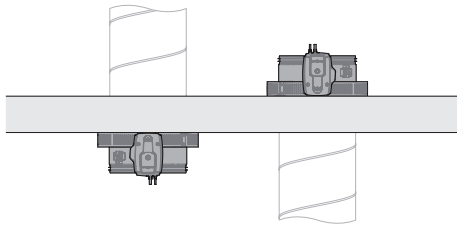

2

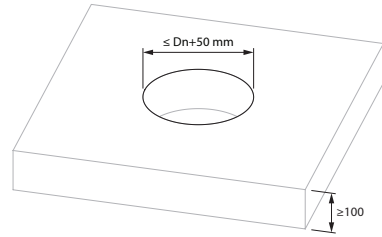

3

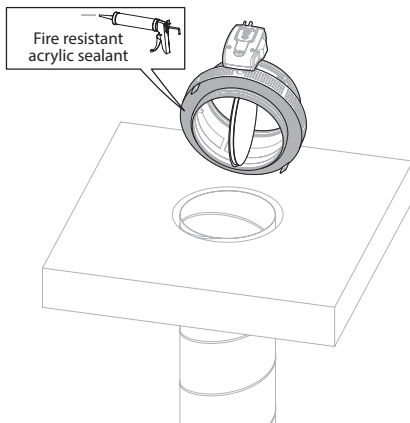

4

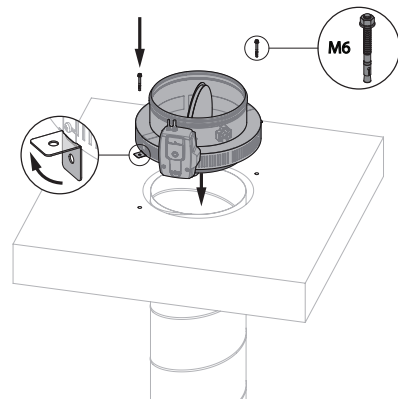

5

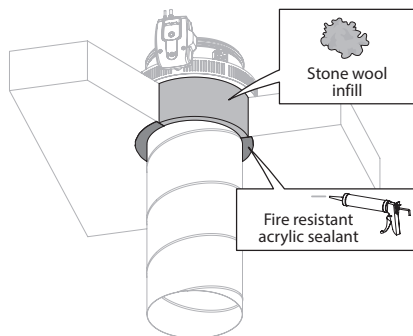

Installation remote from a rigid wall, sealing with acrylic sealant

The product was tested and approved in:

Range	Wall type	Sealing	Classification
Ø 100-630 mm	Rigid wall	Aerated concrete ≥ 100 mm	Fire resistant acrylic sealant
			El 60 (v _e i ↔ o) S - (300 Pa)

1

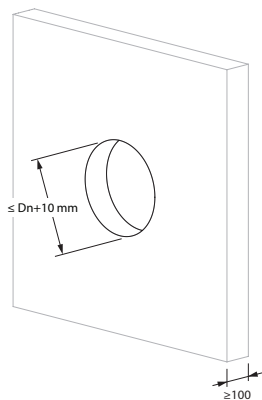

2

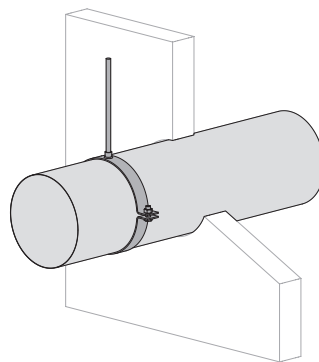

2. Provide suspension where necessary in accordance with the instructions of the duct manufacturer.

3

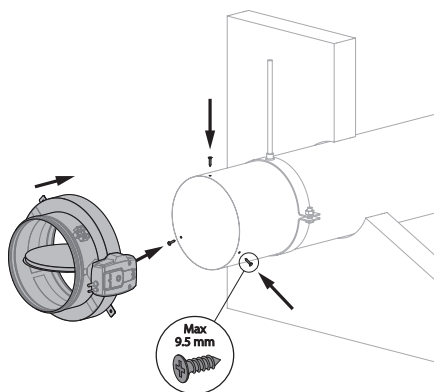

3. Attention: Make sure that the movement of the damper blade is not impeded by the screws.

4

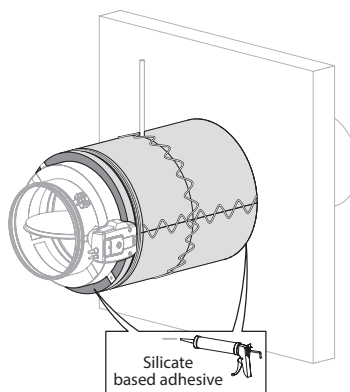

4. Insulate the duct with stone wool (min. EI 60 S) according to the stone wool manufacturer's instructions.

5

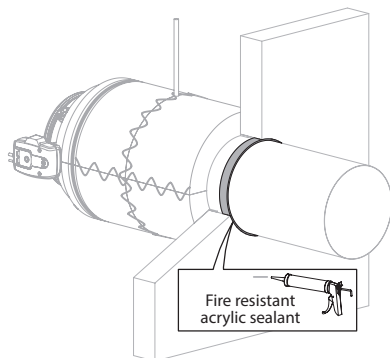

Installation remote from a rigid wall, sealing with stone wool

The product was tested and approved in:

Range	Wall type	Sealing	Classification
Ø 100-630 mm	Rigid wall	Aerated concrete ≥ 100 mm	Stone wool + coating with acrylic sealant
			El 60 (v _e i ↔ o) S - (300 Pa)

1

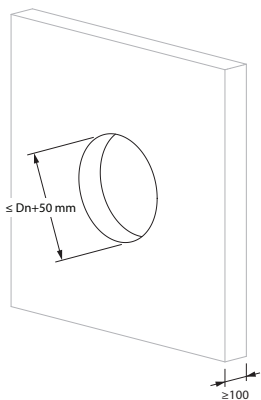

2

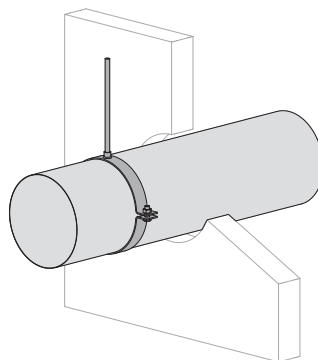

2. Provide suspension where necessary in accordance with the instructions of the duct manufacturer.

3

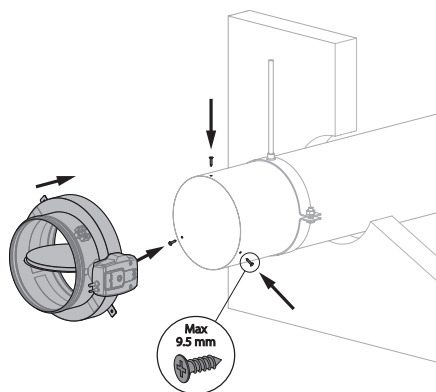

3. Attention: Make sure that the movement of the damper blade is not impeded by the screws.

4

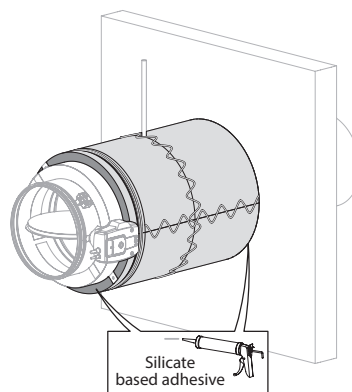

4. Insulate the duct with stone wool (min. EI 60 S) according to the stone wool manufacturer's instructions.

5

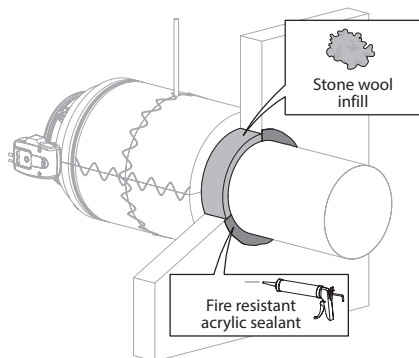

Installation remote from a flexible wall, sealing with acrylic sealant

The product was tested and approved in:

Range	Wall type	Sealing	Classification
Ø 100-630 mm	Flexible wall	Fire resistant acrylic sealant	El 60 (v _e i ↔ o) S - (300 Pa)

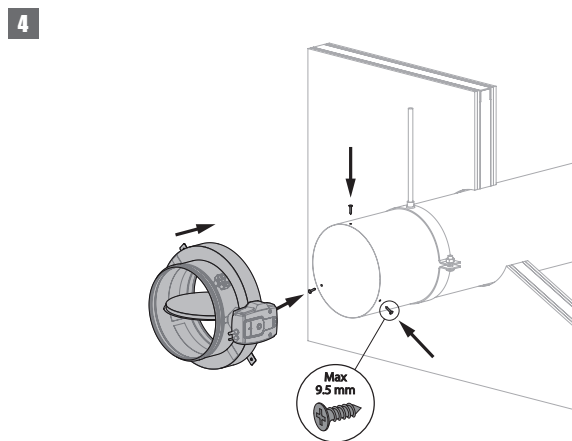
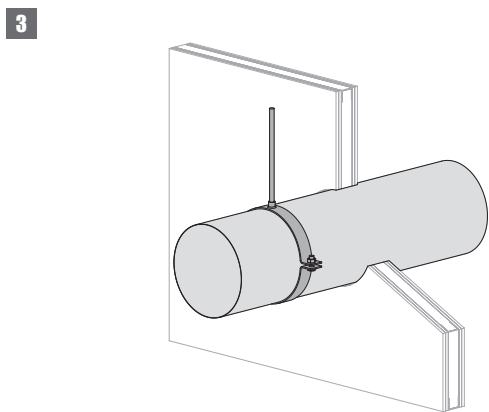
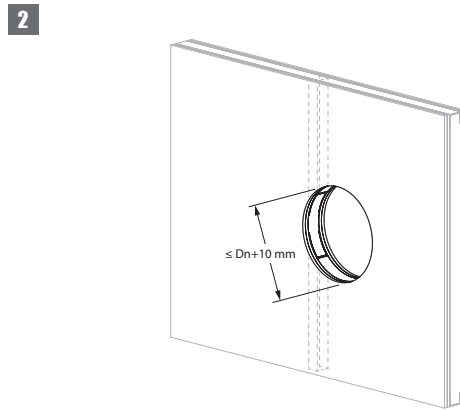
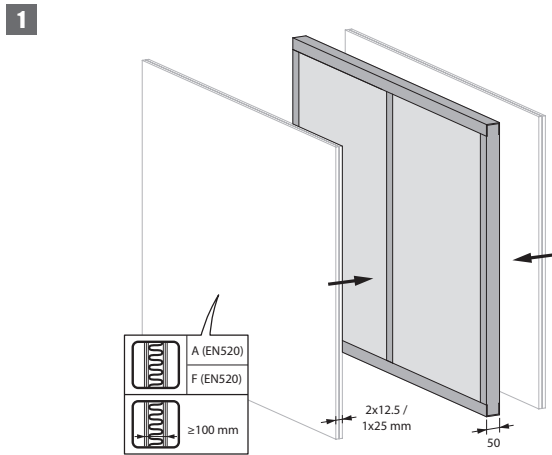

3. Provide suspension where necessary in accordance with the instructions of the duct manufacturer.

4. Attention: Make sure that the movement of the damper blade is not impeded by the screws.

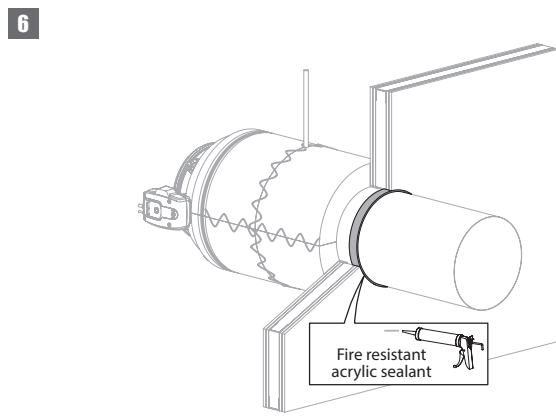
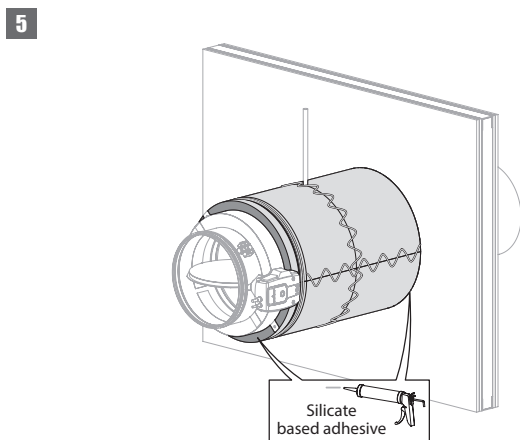

5. Insulate the duct with stone wool (min. El 60 S) according to the stone wool manufacturer's instructions.

Installation remote from a flexible wall, sealing with stone wool

The product was tested and approved in:

Range	Wall type	Sealing	Classification
Ø 100-630 mm	Flexible wall	Stone wool + coating with acrylic sealant	El 60 (v _e i ↔ o) S - (300 Pa)

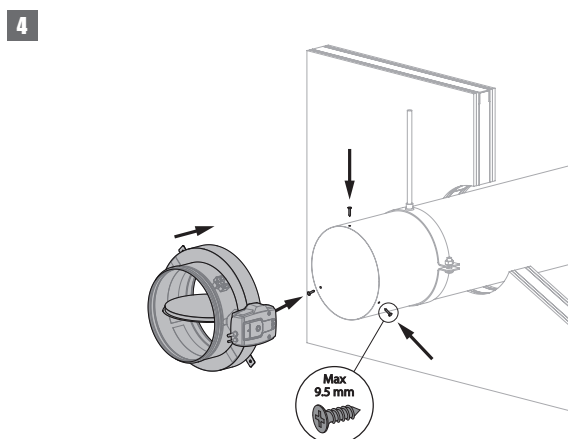
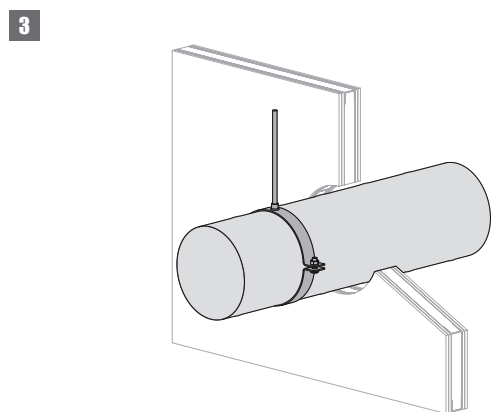
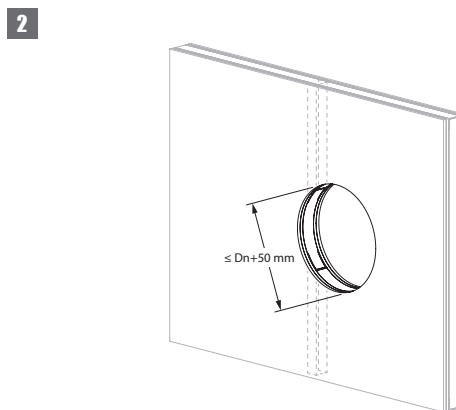
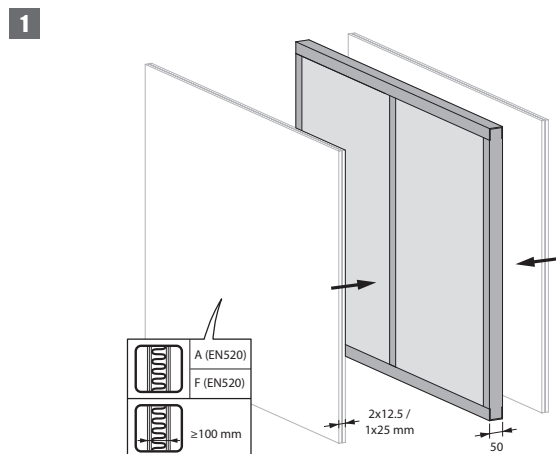

3. Provide suspension where necessary in accordance with the instructions of the duct manufacturer.

4. Attention: Make sure that the movement of the damper blade is not impeded by the screws.

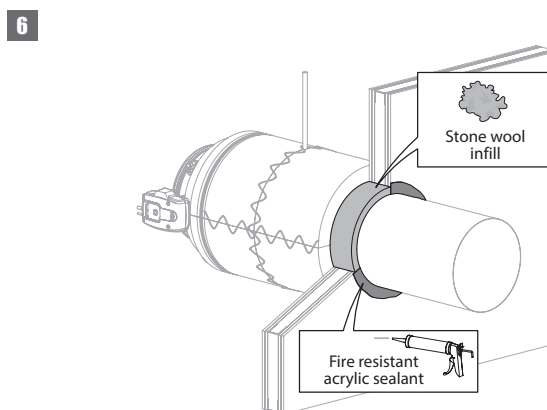
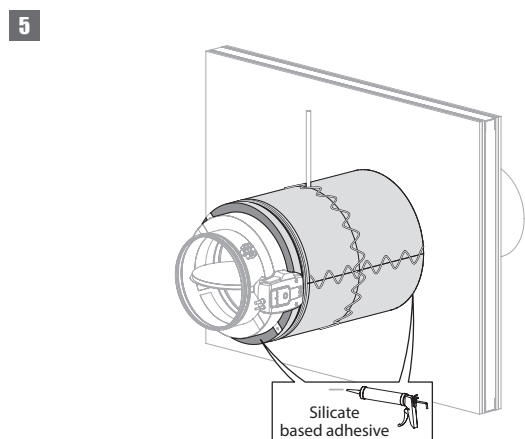

5. Insulate the duct with stone wool (min. El 60 S) according to the stone wool manufacturer's instructions.

Installation remote from a shaftwall

The product was tested and approved in:

Range	Wall type	Sealing	Classification
Ø 100-630 mm	Asymmetrical flexible wall (shaftwall)	Fire resistant acrylic sealant	EI 60 (v _e i ↔ o) S - (300 Pa)

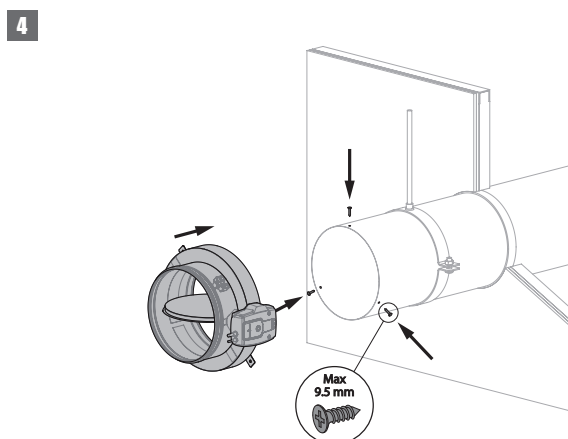
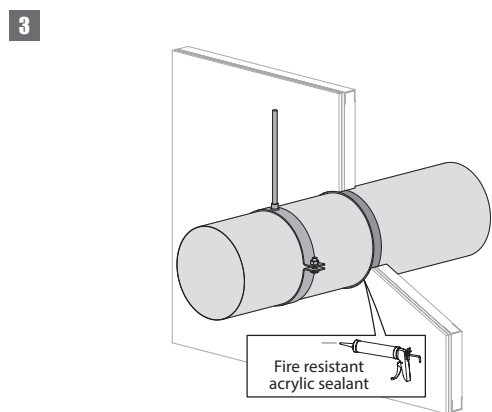
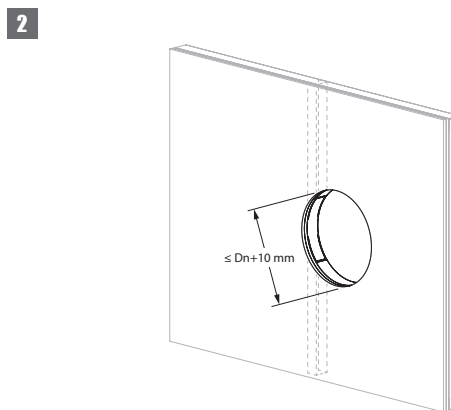
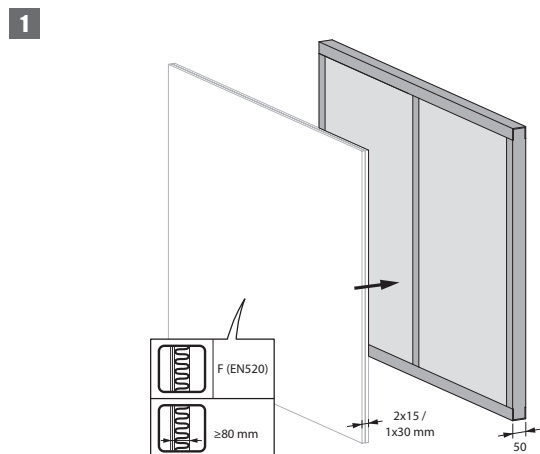

3. Provide suspension where necessary in accordance with the instructions of the duct manufacturer.

4. Attention: Make sure that the movement of the damper blade is not impeded by the screws.

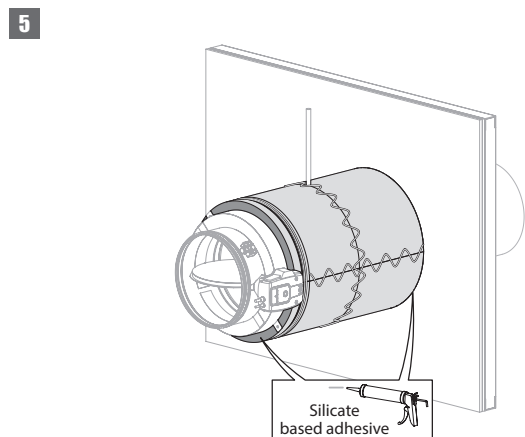

5. Insulate the duct with stone wool (min. EI 60 S) according to the stone wool manufacturer's instructions.

Installation remote from a floor, sealing with acrylic sealant

The product was tested and approved in:

Range	Wall type	Sealing	Classification
Ø 100-630 mm	Rigid floor	Aerated concrete ≥ 100 mm	Fire resistant acrylic sealant
			El 60 (h _o i ↔ o) S - (300 Pa)

1

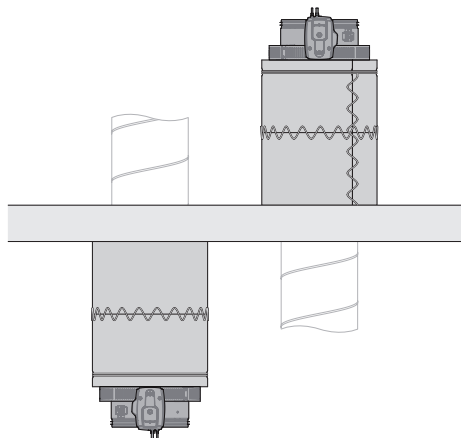

2

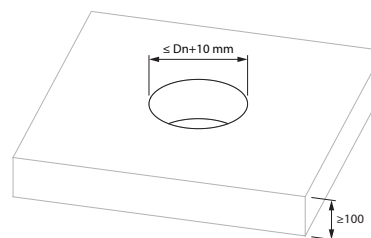

3

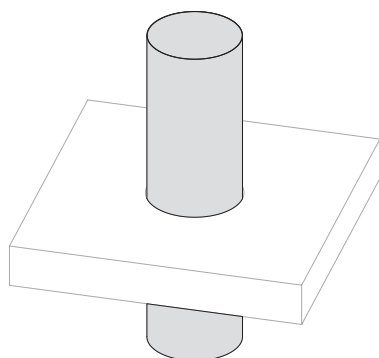

4

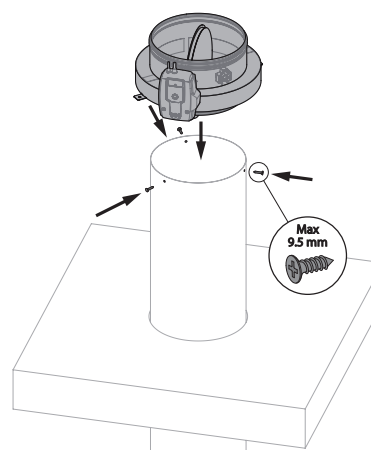

4. Attention: Make sure that the movement of the damper blade is not impeded by the screws.

5

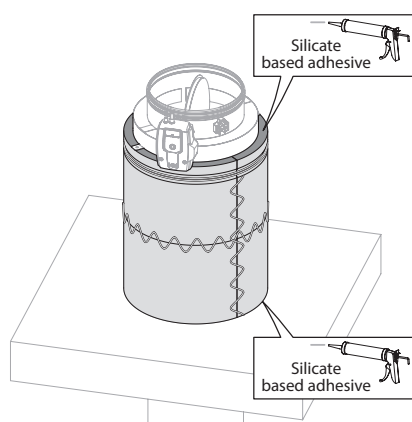

6

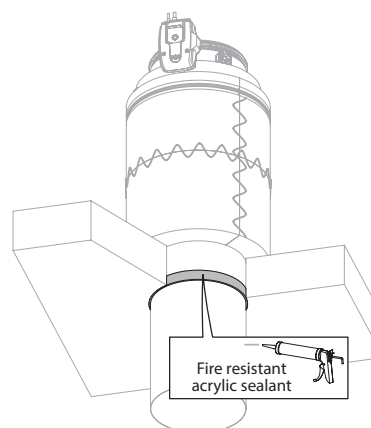

5. Insulate the duct with stone wool (min. EI 60 S) according to the stone wool manufacturer's instructions.

Installation remote from a floor, sealing with stone wool

The product was tested and approved in:

Range	Wall type	Sealing	Classification
Ø 100-630 mm	Rigid floor	Aerated concrete ≥ 100 mm	Stone wool + coating with acrylic sealant
			El 60 (h _o i ↔ o) S - (300 Pa)

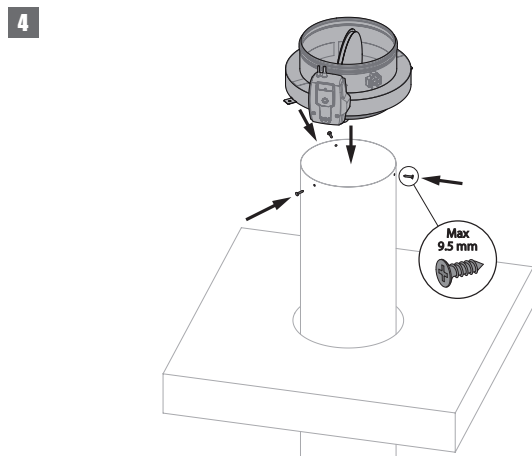
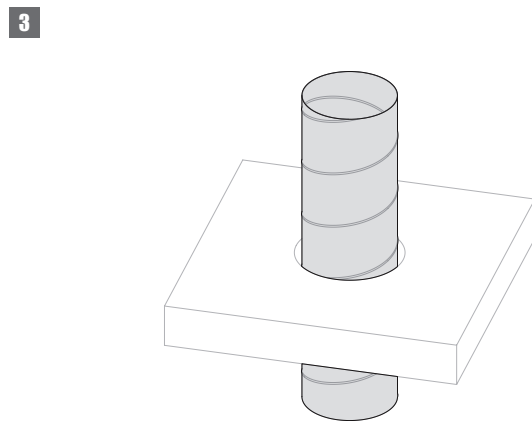
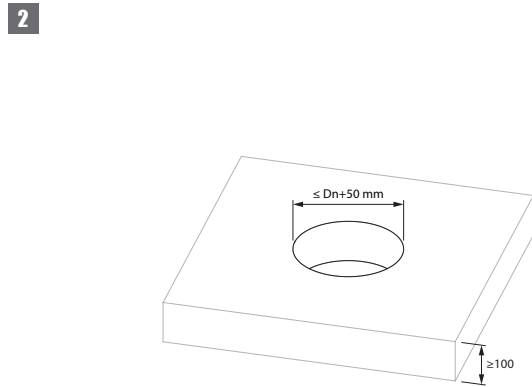
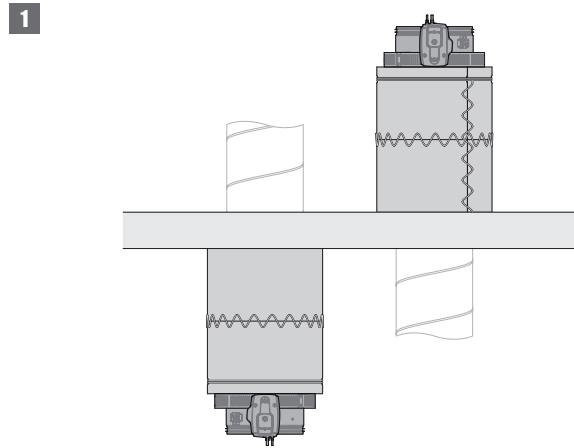

4. Attention: Make sure that the movement of the damper blade is not impeded by the screws.

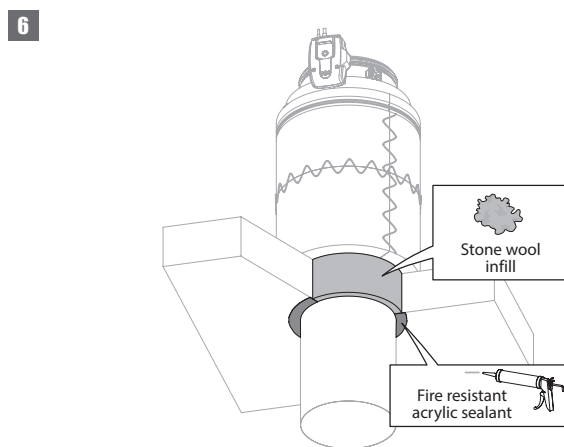
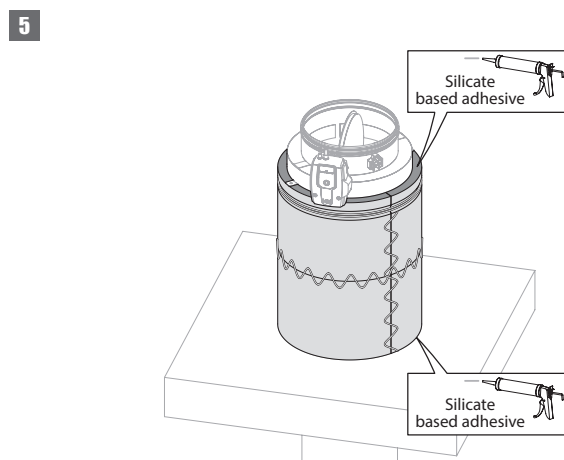

5. Insulate the duct with stone wool (min. El 60 S) according to the stone wool manufacturer's instructions.

Maintenance

- No specific maintenance required.
- Schedule at least 2 visual checks each year.
- Remove dust and all other particles before use.
- Follow local maintenance regulations (i.e. BS9999 Annex V; NF S 61-933) and EN13306.
- Read the maintenance instructions on our website:
https://www.rft.eu/assets/PIM/DOCUMENTS/BROCHURE%20KITS/BRO_K139_MAINTENANCE_C.pdf
- Use the damper at up to 95% humidity, non-condensing.
- The fire damper can be cleaned with a dry or slightly damp cloth. It is forbidden to use abrasive cleaners or mechanical cleaning techniques (brush).

Operation and mechanisms



ONE Spring return actuator for remote control

The spring-return actuator ONE is designed to easily operate Rf-t fire dampers of all sizes, automatically or remotely. The ONE is available in five models: 24 or 230 volts with a beginning -and end of range switch (FDCU) and optionally with a plug (ST), or 24 volts with a double set of beginning -and end of range switches (FDCB).

- 1. unlocking button
- 2. blade position indicator
- 3. LED
- 4. battery compartment to reset motor

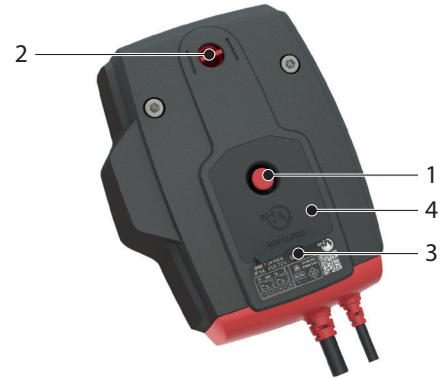

Ontgrendeling

- **manual unlocking:** shortly press the unlocking button (1) once.
- **automatic unlocking:** the fusible link reacts as soon as the temperature in the duct reaches 72°C.
- **remote unlocking:** by interrupting the power supply.

Herwaping

- **manual resetting:** open the battery compartment (4) and press a 9V battery against the contact springs. Hold this position until the LED (3) emits a continuous light.
Check whether the indicator (2) shows that the damper blade is in the open position.
Remove the battery, the LED fades away.
Close the battery compartment.
- **motorised resetting:** switch off the power supply for at least 5 sec. Power the actuator (respect the prescribed voltage) for at least 75 sec. The resetting stops automatically when the end of range is reached (damper open).

Caution:

- “ If the LED (3) flickers fast (3x/sec.), the battery is discharged: use a new battery.
- “ If the LED (3) flickers slowly (1x/sec), the resetting is in progress.
- “ If the LED (3) is continuously on, the resetting is complete and the motor is powered.
- “ If the actuator detects voltage on the power cable, a brief contact of the battery is enough to start the resetting process.
- “ The power supply of this actuator cannot be individually replaced. If the cable is damaged, the whole unit must be discarded and replaced.
- “ The housing of the mechanism contains a temperature sensor. When the temperature in the housing exceeds 72°C, the mechanism unlocks. The LED flashes twice per second. When the temperature drops below 72°C, the mechanism can only be reset in a motorised manner after a manual reset (with a battery).
- “ The end of range switches need 1 second after operation to adopt a stable position.
- “ Make sure the thermal trigger device is present in the actuator. The actuator might not function properly if this is not the case.

	prod. < 1/7/2015				prod. ≥ 1/7/2015			
	CR60(1s) CR120	CU-LT CU-LT-1s	CR2≤400 CU2≤1200	CR2>400 CU2>1200	CR60(1s) CR120(1s)	CU-LT CU-LT-1s	CR2≤400 CU2≤1200	CR2>400 CU2>1200
Kit ONE	●	●	●		●	●	●	●



ONE-X Spring return actuator with integrated communication module.

The ONE-X is a spring return actuator with integrated communication module designed to simply operate Rf-t fire dampers of all sizes, automatically or remotely. The ONE-X is available in two versions: 24 V and 230 V.

1. unlocking button
2. blade position indicator
3. LED red: status
4. battery compartment
5. LED blue: communication
6. LED orange: error message
7. supply
8. bus cable

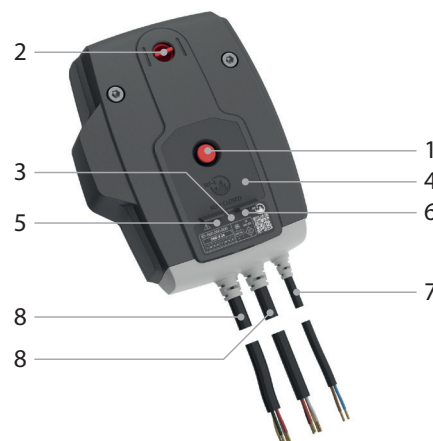

Ontgrendeling

- **manual unlocking:** shortly press the unlocking button (1) once.
- **automatic unlocking:** the fusible link reacts as soon as the temperature in the duct reaches 72°C.
- **remote unlocking:** via ZENiX controller

Herwapening

- **manual resetting:** Open the battery compartment (4) and press a 9V battery against the contact springs. Hold this position until the red LED (3) emits a continuous light. Control whether the indicator (2) indicates that the damper blade is open. Remove the battery. Close the battery compartment.
- **motorised resetting:** via ZENiX controller. By applying voltage during first use.

Caution:

- “ If the ONE-X detects voltage on the power cable, a brief contact of the battery is enough to start the resetting process, provided the ZENiX controller has sent the damper to open position or the ONE-X is being operated for the first time.
- “ The power supply of this actuator cannot be individually replaced. If the cable is damaged, the whole unit must be discarded and replaced.
- “ The housing of the mechanism contains a temperature sensor. When the temperature in the housing exceeds 72°C, the mechanism unlocks. The LED flashes twice per second. When the temperature drops below 72°C, the mechanism can only be reset in a motorised manner after a manual reset (with a battery).
- “ The end of range switches need 1 second after operation to adopt a stable position.

Safety regulations:

- “ Do not use the ONE-X for any application other than the specified applications, in particular not in aircraft or other airborne vehicles.
- “ The company that purchases and/or installs the ONE-X is fully responsible for the correct operation of the entire system. Only authorised specialists may perform the installation. All rules and regulations, including statutory regulations, must be observed during installation.
- “ This device contains electrical or electronic components and must not be disposed of as household waste. All locally applicable regulations and requirements must be strictly observed.



BFLT Remotely controlled spring return actuator

The spring return actuator BFLT is especially designed to operate fire dampers remotely. The BFLT variant is intended for fire dampers with smaller dimensions (CR60, CR120, CR2 with $\varnothing \leq 400$ mm, CRS60 with $\varnothing \leq 315$ mm, CU2 / CU2-15 / CU4 with $W+H \leq 1200$ mm or for CU-LT and CU-LT-1s). For Markage FD with $H = 200$ mm or $H = 2200$ mm (in combination with BFT motor).

1. locking button
2. plug (ST)
3. access for manual resetting
4. thermo-electric tripping device (T)



Options - at the time of order

SN2 BFL/BFN Auxiliary limit switch 'open/closed'

Ontgrendeling

- **manual unlocking:** place the locking button on "unlock" or press the "test" button on the probe.
- **automatic unlocking:** the thermo-electric fuse reacts as soon as the temperature reaches 72°C.
- **remote unlocking:** by interrupting the power supply.

Caution:

" The thermo-electric fuse will not move the damper into its safety position (when the temperature reaches 72°C) if the motor is not powered.

Herwapening

- **manual resetting:** turn the enclosed handle anti-clockwise. To block the motor, place the locking button on "lock"
- **motorised resetting:** switch off the power supply for at least 10 seconds. Supply the actuator (respect the prescribed voltage) for at least 75 seconds. The resetting stops automatically when the end of range is reached (damper open) - it takes about 60 seconds to reset the damper - or when the power supply is interrupted.

Caution:

- " Do not use a drill or powered screwdriver.
- " Stop as soon as the motor is completely rearmed (end of range).

	prod. < 1/7/2015				prod. ≥ 1/7/2015			
	CR60(1s) CR120	CU-LT CU-LT-1S	CR2≤400 CU2≤1200	CR2>400 CU2>1200	CR60(1s) CR120 (1s)	CU-LT CU-LT-1S	CR2≤400 CU2≤1200	CR2>400 CU2>1200
Kit BFLT					•	•	•	
Kit BFNT	•	•	•					•
Kit BFT				•				



BFNT Remotely controlled spring return actuator

The spring return actuator BFNT is especially designed to operate fire dampers remotely. The BFNT variant is intended for fire dampers with large dimensions (CRE60, CR2 with $\varnothing > 400$ mm, CRS60 with $\varnothing > 315$ mm or CU2, CU2-15, CU4 with $W+H > 1200$ mm. For Markage FD with H of 400 and 600 mm or with H = 1200 mm (2 pcs) and with H = 2400 mm (in combination with BFT motor).

1. locking button
2. plug (ST)
3. access for manual resetting
4. thermo-electric tripping device (T)

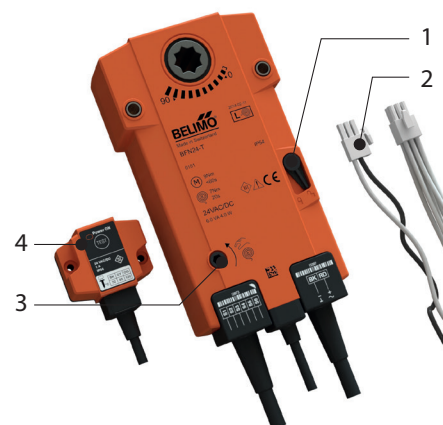

Options - at the time of order

SN2 BFL/BFN Auxiliary limit switch 'open/closed'

Ontgrendeling

- **manual unlocking:** place the locking button on "unlock" or press the "test" button on the probe.
- **automatic unlocking:** the thermo-electric fuse reacts as soon as the temperature reaches 72°C.
- **remote unlocking:** by interrupting the power supply.

Caution:

* The thermo-electric fuse will not move the damper into its safety position (when the temperature reaches 72°C) if the motor is not powered.

Herwapening

- **manual resetting:** turn the enclosed handle anti-clockwise. To block the motor, place the locking button on "lock"
- **motorised resetting:** switch off the power supply for at least 10 seconds. Supply the actuator (respect the prescribed voltage) for at least 75 seconds. The resetting stops automatically when the end of range is reached (damper open) - it takes about 60 seconds to reset the damper - or when the power supply is interrupted.

Caution:

- * Do not use a drill or powered screwdriver.
- * Stop as soon as the motor is completely rearmed (end of range).

	prod. < 1/7/2015				prod. ≥ 1/7/2015			
	CR60(1s) CR120	CU-LT CU-LT-1S	CR2≤400 CU2≤1200	CR2>400 CU2>1200	CR60(1s) CR120 (1s)	CU-LT CU-LT-1S	CR2≤400 CU2≤1200	CR2>400 CU2>1200
Kit BFLT					•	•	•	
Kit BFNT	•	•	•					•
Kit BFT				•				



BFLT-SR Remote-controlled spring return actuator with modulating function

The spring return actuator BFLT24-SR is designed to control fire dampers remotely. The position of the damper blade is adjustable by means of a 0 to 10V connection. Available for: CRS60 ($\varnothing \leq 315$ mm).

1. locking button
2. access for manual resetting
3. thermo-electric tripping device (T)



Ontgrendeling

- **manual unlocking:** place the locking button on “unlock”. The damper can alternatively be unlocked by pushing the “test” button on the thermo-electric fuse.
- **automatic unlocking:** the thermo-electric fuse reacts as soon as the temperature reaches 72°C.
- **remote unlocking:** by interrupting the power supply.

Caution:

“ The thermo-electric fuse will not move the damper into its safety position (when the temperature reaches 72°C) if the motor is not powered.

Herwapening

- **manual resetting:** turn the enclosed handle anti-clockwise. To block the motor, place the locking button on “lock”
- **motorised resetting:** switch off the power supply for at least 10 sec. Supply the actuator (line 1 and line 2; respect the indicated voltage) for min 75 sec. Apply a control voltage between 0 V and 10 V to line 3 and line 1 (0 V = closed, 10 V = fully open; respect the indicated voltage). The movement of the motor stops automatically on reaching the entered position. It takes about 60 sec to fully arm the damper.

Caution:

“ Do not use a drill or powered screwdriver.
 “ Stop as soon as the motor is completely rearmed (end of range).



BFNT-SR Remote-controlled spring return actuator with modulating function

The spring return actuator BFNT24-SR is designed to operate fire dampers remotely. The position of the damper blade is adjustable by means of a 0 to 10V connection. Available for: CRE60 and CRS60 (CRS60 $\varnothing \geq 400$ mm).

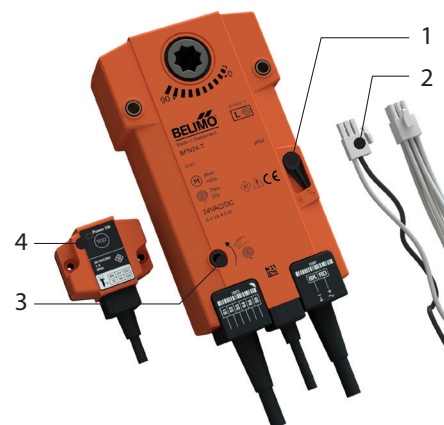

1. locking button
2. access for manual resetting
3. thermo-electric tripping device (T)

Ontgrendeling

- **manual unlocking:** place the locking button on “unlock”. The damper can alternatively be unlocked by pushing the “test” button on the thermo-electric fuse.
- **automatic unlocking:** the thermo-electric fuse reacts as soon as the temperature reaches 72°C.
- **remote unlocking:** by interrupting the power supply.

Caution:

- “ The thermo-electric fuse will not move the damper into its safety position (when the temperature reaches 72°C) if the motor is not powered.

Herwapening

- **manual resetting:** turn the enclosed handle anti-clockwise. To block the motor, place the locking button on “lock”
- **motorised resetting:** switch off the power supply for at least 10 sec. Supply the actuator (line 1 and line 2; respect the indicated voltage) for min 75 sec. Apply a control voltage between 0 V and 10 V to line 3 and line 1 (0 V = closed, 10 V = fully open; respect the indicated voltage). The movement of the motor stops automatically on reaching the entered position. It takes about 60 sec to fully arm the damper.

Caution:

- “ Do not use a drill or powered screwdriver.
- “ Stop as soon as the motor is completely rearmed (end of range).

Electrical connection

ONE

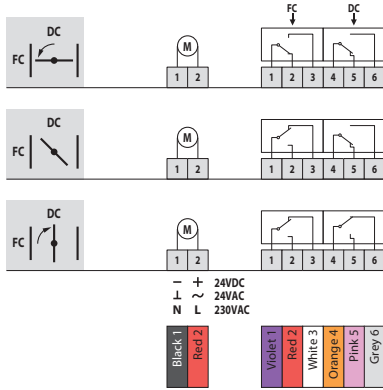

DC: Switch open position fire damper
FC: Switch closed position fire damper

ONE-X

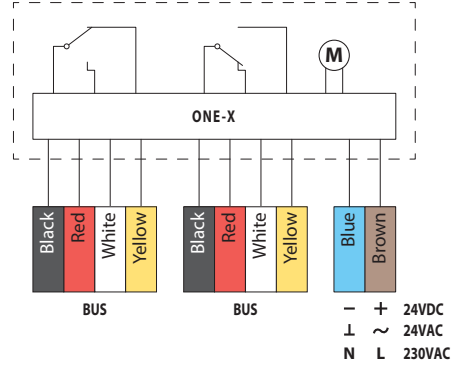

BFLT

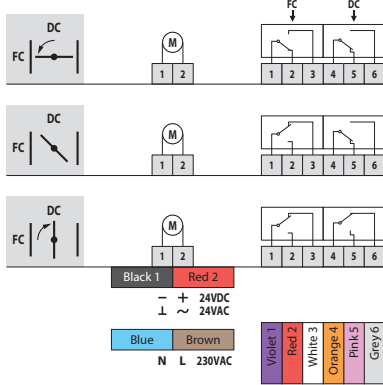

DC: Switch open position fire damper
FC: Switch closed position fire damper

BFNT

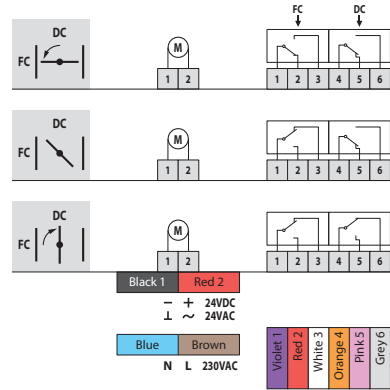

DC: Switch open position fire damper
FC: Switch closed position fire damper

BFLT-SR

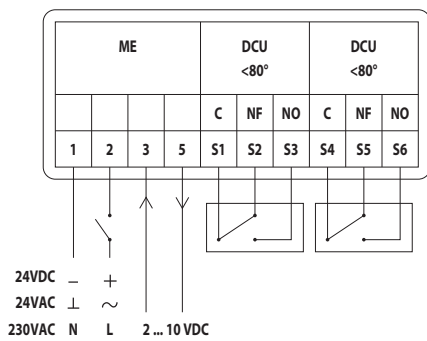

BFNT-SR

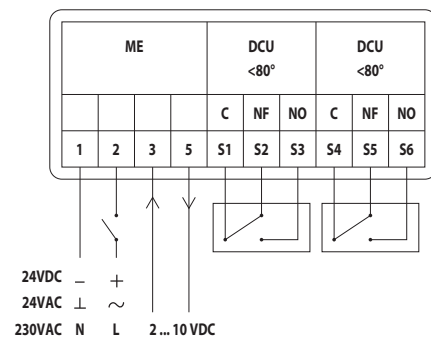

MEC	Nominal voltage motor	Nominal voltage magnet	Power consumption (stand-by)	Power consumption (operating)	Standard switches	Resetting time motor
ONET 24 FDCU L	24 V AC/DC (-10/+20%)	N/A	0,28 W	4,2 W	1mA...1A 60VDC or 1mA...100mA 230VAC	< 75 s (cabled) / <85 s (battery)
ONET 24 FDCU ST L	24 V AC/DC (-10/+20%)	N/A	0,28 W	4,2 W	1mA...1A 60VDC or 1mA...100mA 230VAC	< 75 s (cabled) / <85 s (battery)
ONET 230 FDCU L	230 V AC (-15/+15%)	N/A	0,57 W	4,2 W	1mA...1A 60VDC or 1mA...100mA 230VAC	< 75 s (cabled) / <85 s (battery)
ONET 230 FDCU ST L	230 V AC (-15/+15%)	N/A	0,57 W	4,2 W	1mA...1A 60VDC or 1mA...100mA 230VAC	< 75 s (cabled) / <85 s (battery)
ONE-X 24 L	24 V AC/DC (-10/+20%)	N/A	0,28 W	4,2 W		< 75 s (cabled) / <85 s (battery)
ONE-X 230 L	230 V AC (-15/+15%)	N/A	0,57 W	4,2 W		< 75 s (cabled) / <85 s (battery)
BFLT24	24 V AC/DC	N/A	0,8 W	2,5 W	1mA...3A, AC 250V	< 60 s
BFLT24-ST	24 V AC/DC	N/A	0,8 W	2,5 W	1mA...3A, AC 250V	< 60 s
BFLT230	230 V AC	N/A	1,1 W	3,5 W	1mA...3A, AC 250V	< 60 s
BFLT230-ST	230 V AC	N/A	1,1 W	3,5 W	1mA...3A, AC 250V	< 60 s
BFNT24	24 V AC/DC	N/A	1,4 W	4 W	1mA...3A, AC 250V	< 60 s
BFNT24-ST	24 V AC/DC	N/A	1,4 W	4 W	1mA...3A, AC 250V	< 60 s
BFNT230	230 V AC	N/A	2,1 W	5 W	1mA...3A, AC 250V	< 60 s
BFNT230-ST	230 V AC	N/A	2,1 W	5 W	1mA...3A, AC 250V	< 60 s
BFLT24-SR	24 V AC/DC	N/A	1 W	3 W	1mA...3A, AC 250V	< 60 s
BFNT24-SR	24 V AC/DC	N/A	1,7 W	4,5 W	1mA...3A, AC 250V	< 60 s

MEC	Running time spring	Noise level motor	Noise level spring	Cable supply / control	Cable auxiliary switch	Protection class
ONET 24 FDCU L	< 30 s	< 64 dB (A)	< 67 dB (A)	1 m, 2 x 0.75 mm ² (halogen-free)	1 m, 6 x 0.75 mm ² (halogen-free)	IP 54
ONET 24 FDCU ST L	< 30 s	< 64 dB (A)	< 67 dB (A)	1 m, 2 x 0.75 mm ² (halogen-free)	1 m, 6 x 0.75 mm ² (halogen-free)	IP 54
ONET 230 FDCU L	< 30 s	< 64 dB (A)	< 67 dB (A)	1 m, 2 x 0.75 mm ² (halogen-free)	1 m, 6 x 0.75 mm ² (halogen-free)	IP 54
ONET 230 FDCU ST L	< 30 s	< 64 dB (A)	< 67 dB (A)	1 m, 2 x 0.75 mm ² (halogen-free)	1 m, 6 x 0.75 mm ² (halogen-free)	IP 54
ONE-X 24 L	< 30 s	< 64 dB (A)	< 67 dB (A)	1 m, 2 x 0.75 mm ² (halogen-free)	bus cable: (2x) 1 m, 4 x 0,75 mm ² (halogen-free)	IP 54
ONE-X 230 L	< 30 s	< 64 dB (A)	< 67 dB (A)	1 m, 2 x 0.75 mm ² (halogen-free)	bus cable: (2x) 1 m, 4 x 0,75 mm ² (halogen-free)	IP 54
BFLT24	20 s	< 43 dB (A)	< 62 dB (A)	1 m, 2 x 0.75 mm ² (halogen-free)	1 m, 6 x 0.75 mm ² (halogen-free)	IP 54
BFLT24-ST	20 s	< 43 dB (A)	< 62 dB (A)	1 m, 2 x 0.75 mm ² (halogen-free)	1 m, 6 x 0.75 mm ² (halogen-free)	IP 54
BFLT230	20 s	< 43 dB (A)	< 62 dB (A)	1 m, 2 x 0.75 mm ² (halogen-free)	1 m, 6 x 0.75 mm ² (halogen-free)	IP 54
BFLT230-ST	20 s	< 43 dB (A)	< 62 dB (A)	1 m, 2 x 0.75 mm ² (halogen-free)	1 m, 6 x 0.75 mm ² (halogen-free)	IP 54
BFNT24	20 s	≤ 55 dB (A)	ca. 67 dB (A)	1 m, 2 x 0.75 mm ² (halogen-free)	1 m, 6 x 0.75 mm ² (halogen-free)	IP 54
BFNT24-ST	20 s	≤ 55 dB (A)	ca. 67 dB (A)	1 m, 2 x 0.75 mm ² (halogen-free)	1 m, 6 x 0.75 mm ² (halogen-free)	IP 54
BFNT230	20 s	≤ 55 dB (A)	ca. 67 dB (A)	1 m, 2 x 0.75 mm ² (halogen-free)	1 m, 6 x 0.75 mm ² (halogen-free)	IP 54
BFNT230-ST	20 s	≤ 55 dB (A)	ca. 67 dB (A)	1 m, 2 x 0.75 mm ² (halogen-free)	1 m, 6 x 0.75 mm ² (halogen-free)	IP 54
BFLT24-SR	20 s	< 43 dB (A)	< 62 dB (A)	1 m, 4 x 0.75 mm ² (halogen-free)	1 m, 6 x 0.75 mm ² (halogen-free)	IP 54
BFNT24-SR	20 s	< 55 dB (A)	< 67 dB (A)	1 m, 4 x 0.75 mm ² (halogen-free)	1 m, 6 x 0.75 mm ² (halogen-free)	IP 54

Weights

CRS60 + ONE

ØDn [mm]	100	125	160	200	250	315	400	500	630	
kg	4,1	4,5	5,1	5,8	7,1	8,6	14,1	14,3	20,1	

CRS60 + ONE-X

ØDn [mm]	100	125	160	200	250	315	400	500	630	
kg	4,1	4,5	5,1	5,8	7,1	8,6	14,1	14,3	20,1	

CRS60 + BFLT

ØDn [mm]	100	125	160	200	250	315	400	500	630	
kg	3,7	4,1	4,7	5,4	6,7	8,2	-	-	-	

CRS60 + BFNT

ØDn [mm]	100	125	160	200	250	315	400	500	630	
kg	-	-	-	-	-	-	14,0	14,2	20,0	

CRS60 + BFLT24-SR

ØDn [mm]	100	125	160	200	250	315	400	500	630	
kg	3,7	4,1	4,7	5,4	6,7	8,2	-	-	-	

CRS60 + BFNT24-SR

ØDn [mm]	100	125	160	200	250	315	400	500	630	
kg	-	-	-	-	-	-	14,0	14,2	20,0	

Selection data

$$\Delta p \text{ (Pa)} = 0,6 \times v^2 \times \zeta$$

ØDn [mm]	100	125	160	200	250	315	400	500	630
ζ [-]	0,7610	0,5715	0,4248	0,3425	0,2680	0,2165	0,2147	0,1913	0,1693

CRS60 - A-weighted sound power level L_{wa} in the room

ØDn [mm]	100	125	160	200	250	315	400	500	630	
Sn [m ²]	0,0063	0,0102	0,0174	0,0279	0,0446	0,0722	0,1136	0,1812	0,2925	
Sn [%]	80,00	83,00	86,00	89,00	91,00	93,00	90,00	92,00	94,00	
Q [m ³ /h]	217	364	645	1.080	1.771	2.501	3.628	5.056	7.141	
Δp [Pa]	26,80	23,30	20,20	18,70	16,20	10,30	8,30	5,90	4,10	45 dB
Q [m ³ /h]	179	301	533	893	1.502	2.121	3.077	4.288	6.057	
Δp [Pa]	18,40	15,90	13,80	12,80	11,60	7,40	6,00	4,20	3,00	40 dB
Q [m ³ /h]	148	249	441	739	1.274	1.799	2.610	3.637	5.137	
Δp [Pa]	12,60	10,90	9,50	8,80	8,40	5,30	4,30	3,00	2,10	35 dB
Q [m ³ /h]	123	206	365	611	1.081	1.526	2.213	3.084	4.357	
Δp [Pa]	8,60	7,50	6,50	6,00	6,00	3,80	3,10	2,20	1,50	30 dB
Q [m ³ /h]	101	170	302	506	917	1.294	1.877	2.616	3.695	
Δp [Pa]	5,90	5,10	4,40	4,10	4,30	2,80	2,20	1,60	1,10	25 dB

Every air flow lower than the above mentioned maximum value, will meet the listed A-weighted sound power level for the respective dimension. More information on sound power can be found in the product information on our website (documents).

Sample order

CRS60	250	ONE T 24 FDCU L
1	2	3

1. product
2. diameter
3. mechanism type

Approvals and certificates

All our dampers are submitted to a number of tests by official test institutes. Reports of these tests form the basis for the approvals of our dampers.



BCCA- 0749-CPR-BC1-606-0464-15650.20-2517

40194