

# Installation Instructions for the TBLA Air Heater with Thermo Guard frost damage protection, GOLD/SILVER

## 1. General

The TBLA air heater uses hot water as the heating medium for post-heating the supply air.

Finned-tube heat exchanger fabricated of copper tubes and profiled aluminium fins. The headers and the pipe-work to the water connections are made of copper. The male threaded pipe connections are made of brass.

### Extra accessories

GOLD:

The TBVL valve set with 2(3)-way valve, actuator, connection cable with quick-fit connector, frost guard sensor (insertion type), and T-piece (for air heaters without outlet for an insertion sensor). See the individual instructions for the TBVL valve set.

If you use a valve of your own, you have the option of instead selecting a set of electrical connection components. This set contains a connection cable with quick-fit connector, resistor and insertion or strap-on sensor.

SILVER:

The TBVA Valve set consisting of a 2(3)-way valve including actuator can be ordered. See the instructions for TBVA accessories. If the air heater/cooler is to be installed outdoors or in a cold space, take into consideration the enclosure class of the actuator and the permissible ambient temperature. If necessary, ensure that the required protection is arranged.

## 2. Maintenance

Check at least twice a year whether cleaning is necessary.

Cleaning shall only be done by blowing with compressed air against the ordinary direction of airflow, vacuum cleaning with a soft nozzle or wet cleaning with water and/or solvent. Before you begin wet cleaning, you should cover adjacent functional sections to protect them. After wet cleaning, you should blow the surfaces dry with compressed air to remove every trace of cleaning solvent.

If cleaning solvent is used, this solvent must not contain ingredients that will corrode aluminium or copper. Swegon's cleaning agent is recommended. This cleaning agent is sold by Swegon or Swegon Service.

While cleaning, check whether the liquid circuit needs to be vented.

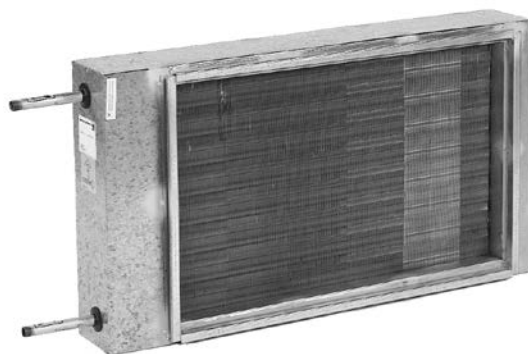

### 3. Installation

For the installation of air heaters in duct systems, see the individual instructions entitled: Installation Instructions for Duct Accessories.

The capacity of the air heater with Thermo Guard is independent on the direction of airflow through the air heater. See Fig. 1.

The return pipe must always be connected to the connection marked Thermo Guard. See figure. 2.

Use a pipe wrench to restrain the pipe connections of the air heater when tightening the external pipe connections to avoid damaging the tubes in the air heater.

Always fill the air heater with liquid from the lower connection. Vent the system before you commission it.

The supply flow temperature should be between 55-70°C.

The available pump pressure must not be higher than 25 kPa if the inlet flow temperature is higher than 65°C. If the inlet flow temperature is between 55°C and 65°C, the available pump pressure should be between 12–40 kPa.

If the inlet flow pressure substantially exceeds the recommended pressure, a pressure limiting device, which reduces the pressure to the recommended level, may be necessary.

A pressure limiting device should not be installed in ventilation systems that utilize hot water supplied from a district heating plant, since such a device could contribute to high recirculated water temperatures.

### 4. Operation

#### Thermo Guard frost damage protection

Frost damages in the air heater most often cause the tube bends to burst.

Research has shown that the tubes in the air stream are the first ones to freeze. When an ice plug forms inside a tube, it expands longitudinally along the tube and this increases the water pressure in the bend causing it to burst. Hence, it is not the ice itself that causes the bend to burst, but the high water pressure in the bend brought about by the ice inside the tube.

Thermo Guard frost-damage-protected air heaters operate according to the principle that involves relieving abnormal pressure rise in tube bends by draining water from the tube bends to the return pipe of the air heater.

This enables the air heater to cope with freezing without damage. However it is important to note that possible valves installed in the return pipeline must not be closed since doing so will put the Thermo Guard function out of action.

Thermo Guard frost damage protection is the only one of its kind on the market that offers frost damage protection in the event of a power failure and similar service disruptions.

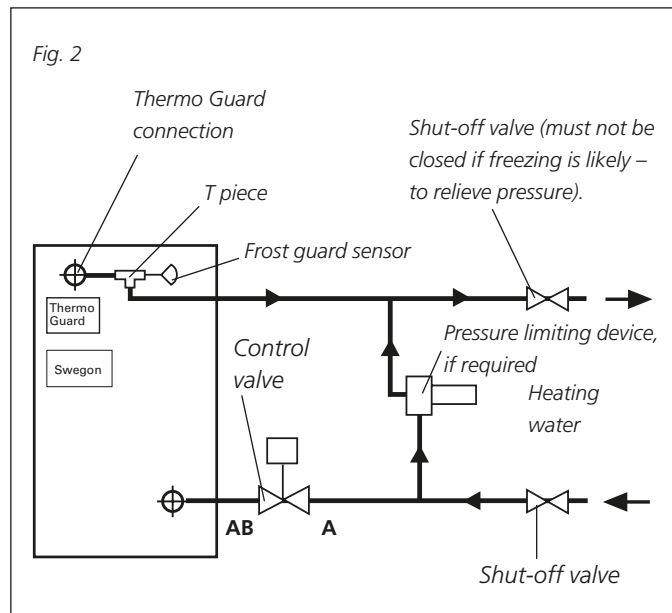
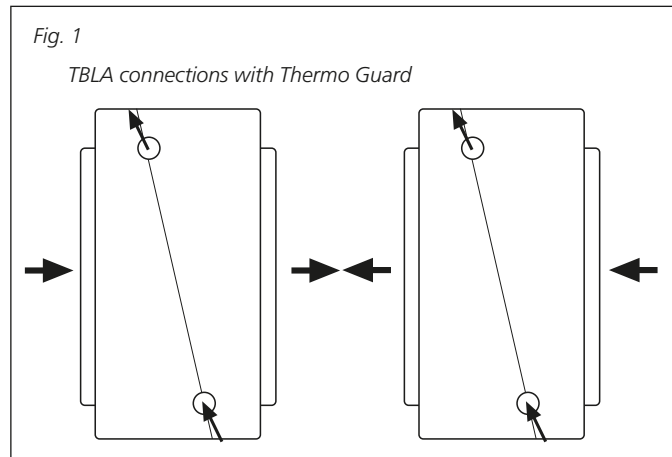

### 5. Electrical connections

For particulars of the electrical connections of the valve actuator and circulation pump, see the separate instructions for the TBVL/TBVA valve kit.