

FUNCTIONAL DIAGRAM Ventilation unit

Automation

ALARM DI / Modbus					
UNIT STATE DI / Modbus					
MEASUREMENT AI/Modbus					
CONTROL DO / Modbus					
CONTROL AO / Modbus					

- * CONFIGURATION AT SITE
- ∟ CONNECTION AT SITE
- ◆ HARDWARE CONNECTION
- ◇ PROGRAM FUNCTION

Electrical cabinet

230VAC 50Hz 10A					
UI					
IO1 / IO2*					
SEC/SEM IO3-IO4,AO4*					
SEC/SEM Modbus*					
SET					

ALARM					
UNIT STATE					
MEASUREMENT					
CONTROL					
CONTROL AO					

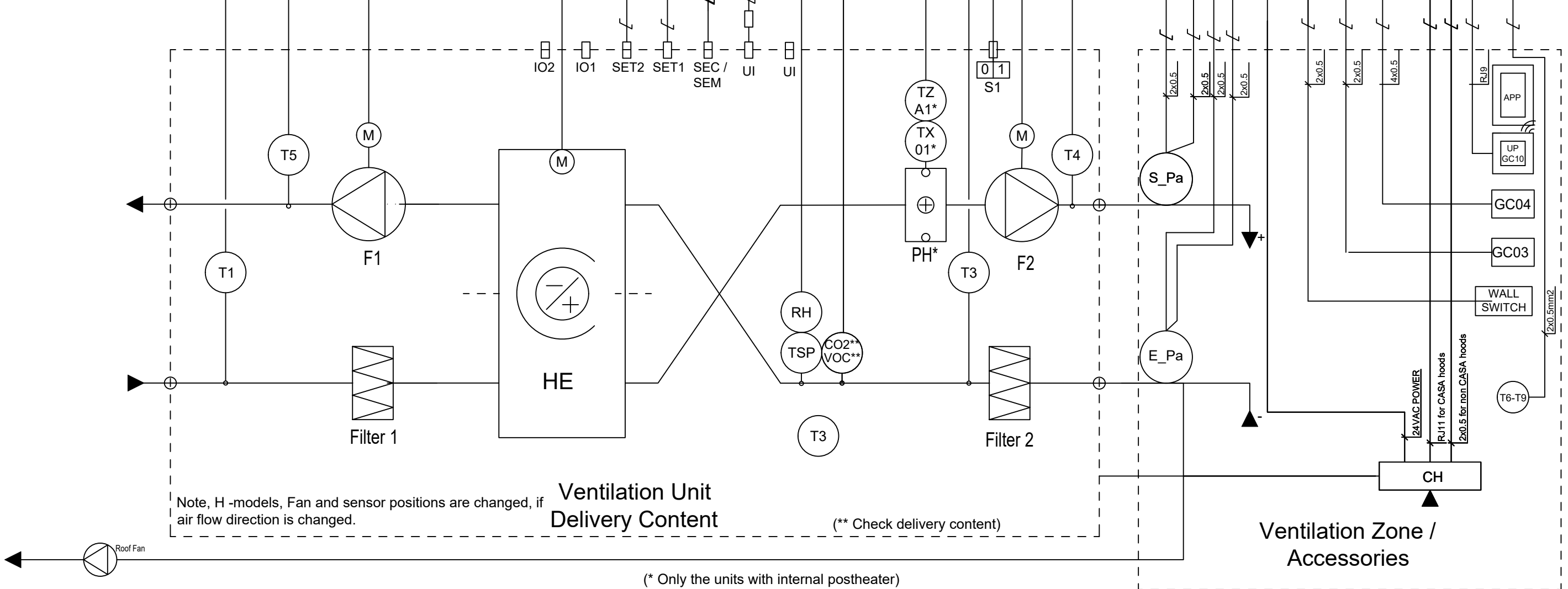



SUUNN.	VERSIO.
XX	2.16
PVM.	
1.6.2026	
ALLEKIRJOITUS	

DIAGRAM
SWEGON CASA
Ventilation unit

**R7/R7-H
Genius**

SUUNNITTELUALA, TYÖN JA PIIRUSTUKSEN N:O		MUUTOS
LVI		
LEHTI	LEHDISTA	TILAAJAN N:O
	1 / 7	

FUNCTIONAL DIAGRAM Duct accessories

 CONNECTION AT SITE, CABLES INCLUDED IN DELIVERY
 CONNECTION AND CABLES AT SITE

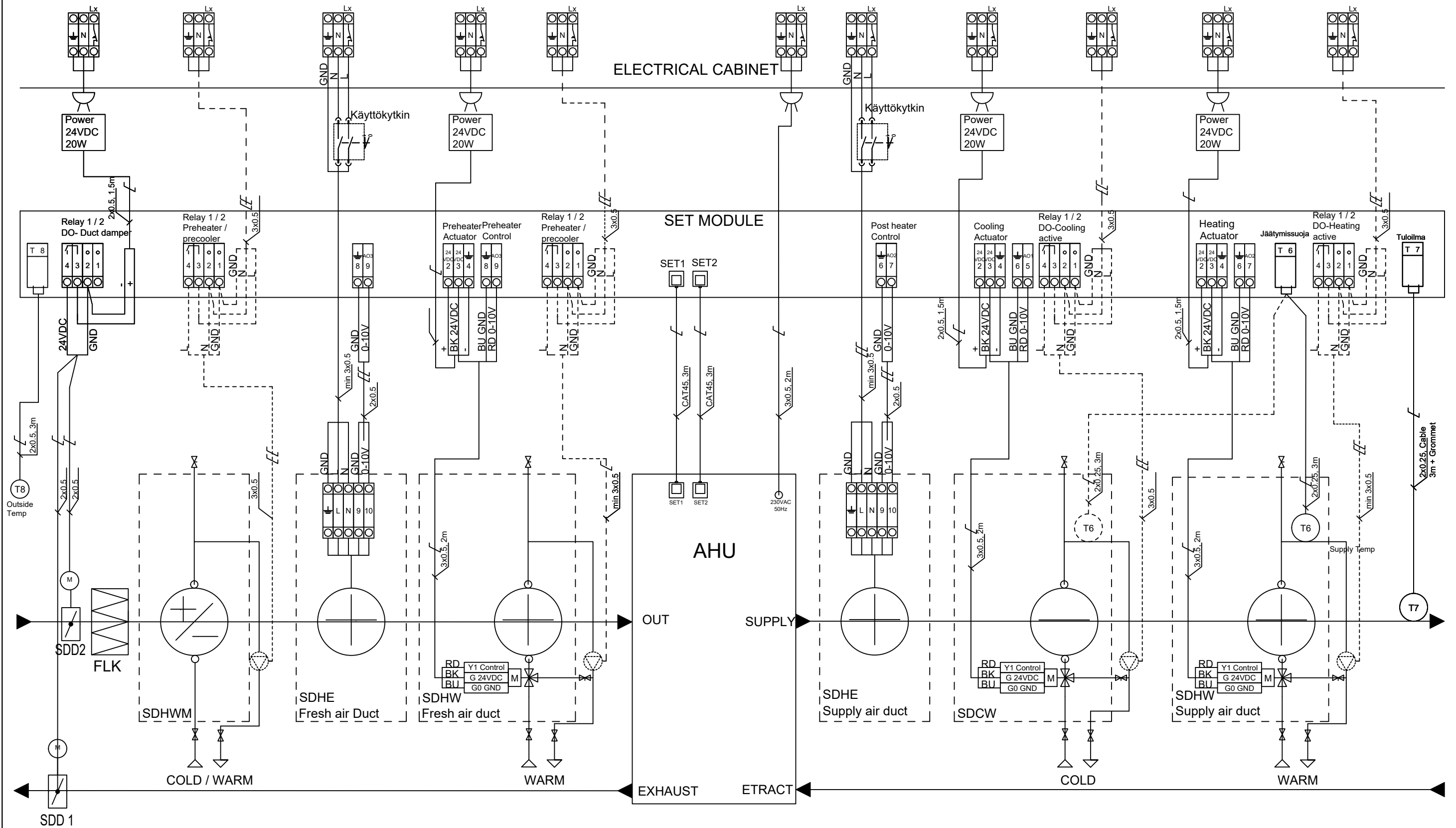

SUUNN.	VERSIO.
XX	2.16
PVM.	
1.6.2026	
ALLEKIRJOITUS	

DIAGRAM
 SWEGON CASA
 Duct Accessories

R7/R7-H
Genius

SUUNNITTELUALA, TYÖN JA PIIRUSTUKSEN N:O		MUUTOS
LVI		
LEHTI	LEHDISTÄ	TILAAJAN N:O
	2 / 7	

DEVICE LIST Ventilation unit

Identifier	Description	Modbus
T1	Temperature sensor Outdoor air / Extract air(H-model when airflow direction reversed)	3x6201 (0,1°C)
T3/TSP	Temperature sensor Extract air (T3 sensor only revA units)	3x6204 (0,1°C)
T4	Temperature sensor Supply air / Exhaust air(H-model when airflow direction reversed)	3x6203 (0,1°C)
T5	Temperature sensor Exhaust air / Supply air(H-model when airflow direction reversed)	3x6205 (0,1°C)
RH	Humidity sensor Extract air. Function: RH Automation(standard)	3x6214 (%)
CO2	Carbon dioxide sensor, function: CO2 automation (Accessory)	3x6213(ppm)
VOC	VOC sensor, function: VOC automation (Accessory)	3x6217(ppm)
TZ01*	Manual reset overheat protection 70 C. Activation of the overheat protection shuts down the heater and triggers an alarm.	TZ01 3x6117
TZA1*	Automatic reset overheat protection 55 C. Activation of the overheat protection shuts down the heater and triggers an alarm.	TZA1 3x6117
Filter 1	Outdoor air filter ISO ePM1 50% (F7). Activate the service reminder to ensure the unit alerts when the filter needs replacement.	3x6129
Filter 2	Exhaust air filter ISO ePM1 50% (F7). Activate the service reminder to ensure the unit alerts when the filter needs replacement.	3x6129
F1	Extract fan (Supply fan H-model when airflow direction reversed), equipped with internal overheat protection	3x6304(%), 3x6306(rpm)
F2	Supply fan (Extract fan H-model when airflow direction reversed), equipped with internal overheat protection	3x6303(%), 3x6305(rpm)
EMI	EMC interference protection for fans	
PH*	Post heater (1400W), stepless and demand-controlled.	3x6317 (%)
HE	Rotating heat exchanger (Rotor)	
HE M	Heat exchanger motor with stepless speed control based on supply air temperature	3x6332 (0.1rpm)
S1	Service switch. Note! During maintenance work, the unit must be disconnected from power by unplugging the power cord.	
(* Only for units with internal post-heating element)		

	SUUNN.	VERSIO.	DEVICE LIST SWEGON CASA Ventilation unit	R7/R7-H Genius	SUUNNITTELUALA, TYÖN JA PIIRUSTUKSEN N:O MUUTOS		
	XX	2.16			LVI		
	PVM.	1.6.2026			LEHTI	LEHDISTÄ	TILAAJAN N:O
	ALLEKIRJOITUS				3 / 7		

AHU External Connections

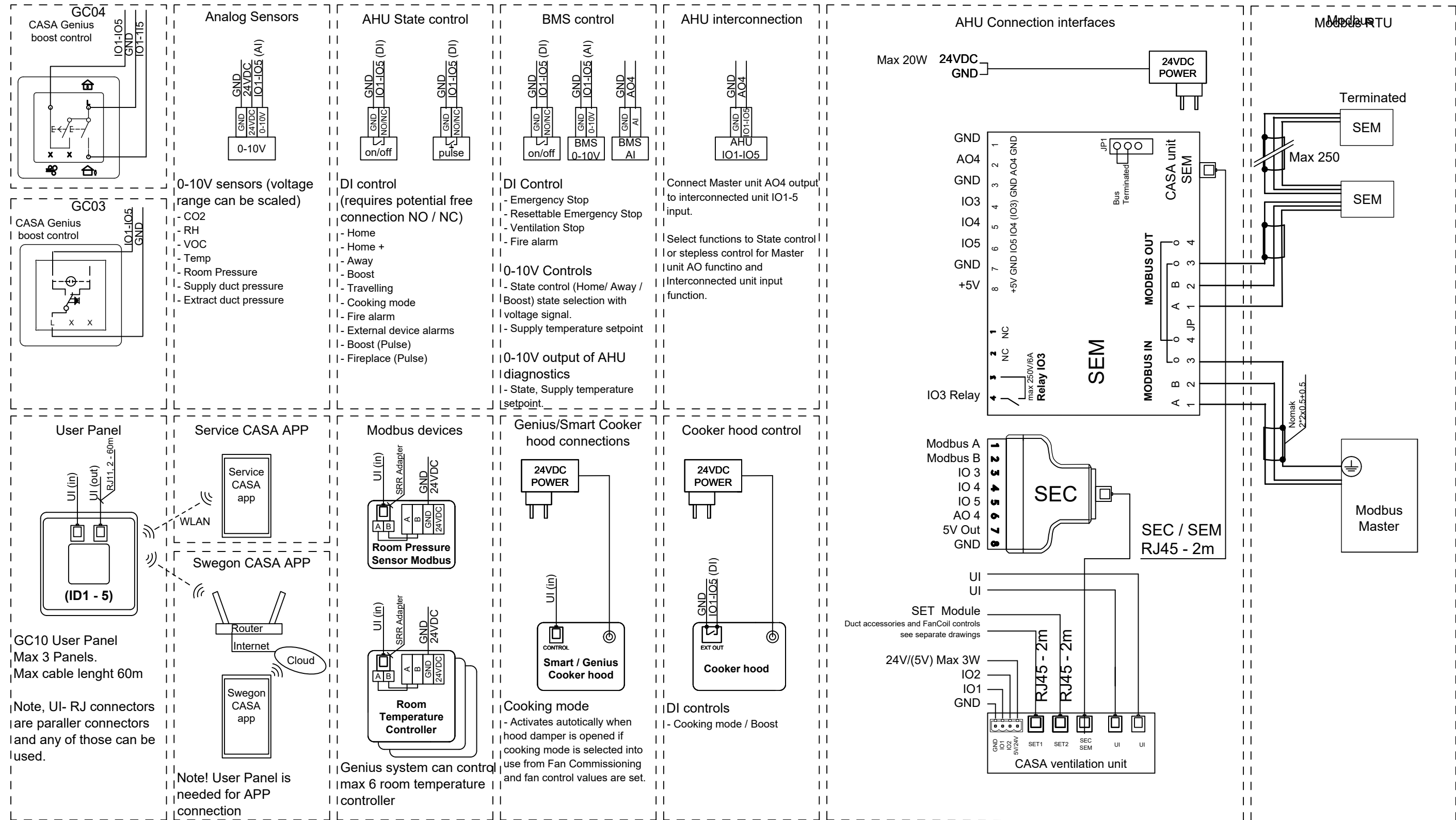

Note! External connection must be configured by using the control panel or by modbus. Commissioning menu code is 1234 by default.

SUUNN.	VERSIO.
XX	2.16
PVM.	1.6.2026
ALLEKIRJOITUS	

CONNECTIONS
SWEGON CASA
Accessories

R7/R7-H
Genius

SUUNNITTELUALA, TYÖN JA PIIRUSTUKSEN N:O		MUUTOS
LVI		
LEHTI	LEHDISTÄ	TILAAJAN N:O
	4 / 7	

CONFIGURATION

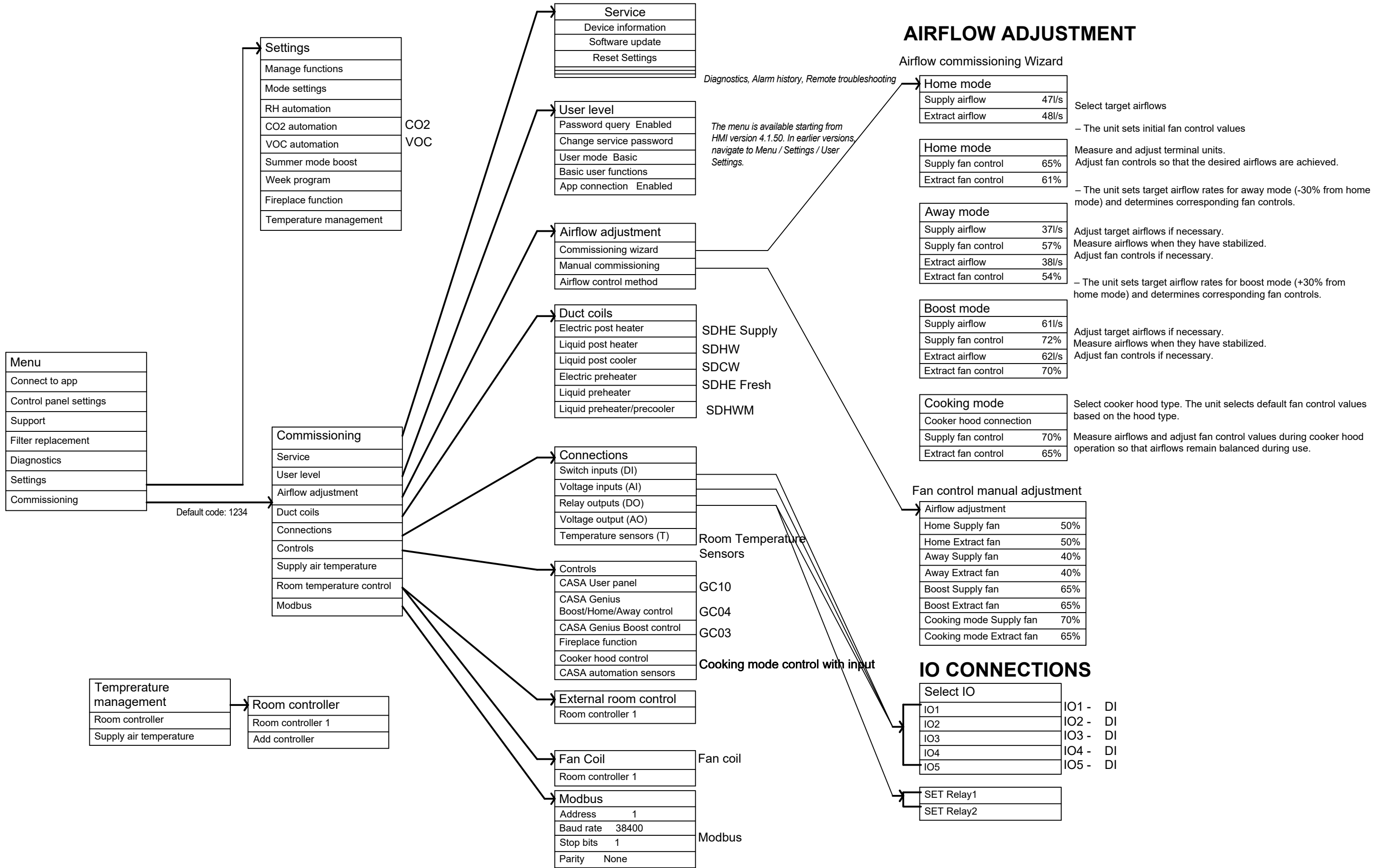

SUUNN.	XX	VERSIO.	2.16
PVM.	1.6.2026		
ALLEKIRJOITUS			

CONFIGURATION
SWEGON CASA

R7/R7-H Genius

SUUNNITTELUALA, TYÖN JA PIIRUSTUKSEN N:O		MUUTOS
LVI		
LEHTI	LEHDISTÄ	TILAAJAN N:O
	5 / 7	

FUNCTIONAL DESCRIPTION GENIUS CONTROL SYSTEM

CONTROL:

The ventilation unit's operating modes can be controlled via the Genius control panel, Swegon CASA cooker hood, Swegon CASA APP (iOS, Android), external switches, weekly timer, or CO₂ automation.

Operating modes can also be controlled via building automation using the Modbus RTU bus or voltage / digital input control signals. The basic operating modes are Away / Home / Boost. Additionally, the control panel or automation can be used to select Travelling, Home+, or Stop modes.

For the Travelling and Home+ modes, the user can define the desired ventilation power levels.

Fan control:

The fans are controlled either by fixed-speed control or by duct pressure*, according to the operating modes adjusted during commissioning.

When the fans are controlled automatically with smooth transitions between different modes, the fan control signals are scaled based on the adjusted modes, ensuring balanced airflow throughout the entire operating range.

Temperature control:

The ventilation unit is equipped with a steplessly controlled rotary heat exchanger. The supply air temperature can be adjusted by controlling the rotation speed of the heat exchanger. The setpoint for the supply air temperature can be selected from the control panel (default: +17 °C). In summer mode, the unit uses a dedicated supply air temperature setpoint (default: +15 °C).

Summer mode is activated automatically based on temperature conditions or can be manually enabled or disabled from the control panel.

If a cooling coil* is installed in the supply air duct, the cooling valve is controlled steplessly. The cooling mode's supply air setpoint can be selected from the control panel. Note that cooling mode can only be activated when summer mode is active.

In winter mode, bypassing the heat exchanger is not allowed, and the unit maintains the set supply air temperature by controlling the reheater. An outdoor temperature limit (default: +8 °C) can be defined for the internal electric reheater.

If a water-based reheating coil is installed in the supply duct, it is prioritized, and the internal heater is used only if the water coil's power is insufficient.

Winter mode is activated based on outdoor temperature or when the heat exchanger is unable to maintain a sufficiently high supply air temperature. If the reheaters cannot maintain the supply temperature (temperature difference to setpoint exceeds -2 °C), the total airflow is reduced.

The supply air setpoint can be adjusted from the control panel, by automatic summer mode logic, or via building automation. In winter mode, the setpoint can be lowered in Away and Vacation modes to save energy. These modes can be scheduled using the weekly timer. Alternatively, the supply air temperature can be controlled based on room air temperature. In this case, the desired room temperature and supply air limits are set. When summer mode is active, the supply air temperature setpoint switches to a fixed summer setpoint.

Summer mode boost:

When summer mode is active, stepless ventilation boost is allowed. The boost level is determined based on the cooling demand and the supply air temperature. This function is enabled by default but can be disabled from the control panel or set to Auto+ mode, which maximizes airflow to enable night cooling.

Cooking mode:

For cooking mode, the supply and extract fan speeds can be adjusted separately, allowing the ventilation to be balanced during cooker hood use. The function is activated automatically when a Swegon CASA cooker hood is connected to the unit or when the hood's status signal is connected to the unit's IO input. Airflows can be adjusted in the commissioning mode.

Fireplace function:

The intelligent fireplace function makes it easier to light a fire by creating a temporary overpressure in the building. After that, the function aims to enable clean combustion by supplying additional compensation air.

Note: It is always necessary to ensure sufficient compensation air for the fireplace. More information available at casaemmanual.com

RH automation:

The unit comes equipped with standard RH automation, which boosts ventilation steplessly according to the normal humidity load caused by human activity. The function is fully automatic and adapts to the environment, so no manual adjustment is required. The response level of the function can be modified if necessary. More information is available at casaemmanual.com

CO₂ automation:

The function adjusts the ventilation level steplessly based on CO₂ levels. If necessary, the function switches the unit to away mode, allowing, for example, a lower supply air temperature. The function must be configured according to the operating mode by setting CO₂ threshold values for both away and home modes. More information is available at casaemmanual.com

VOC automation:

The function boosts ventilation steplessly based on indoor air quality (VOC). The function is automatic, and its response level can be adjusted if necessary. More information is available at casaemmanual.com

*Assessory

COMPONENT INTERNAL PROTECTION FUNCTIONS

Electrical heaters:

Electrical heaters are equipped with automatic and manual resettable overheating protection. Manual resettable protection can be reset by pressing reset button.

Fans:

Fans are equipped with internal automatic overheating protection.

Software-based protection functions

Filters:

The service reminder indicates the need to replace the filter on the control panel, Swegon CASA cooker hood, as a DO status signal, or via the Modbus communication bus. The service reminder interval is adjustable and can be reset from the user interface.

Water coils

Water coils are equipped with a frost protection sensor. If the water temperature drops below the alarm limit, a freezing risk alarm is activated, and heating is set to maximum. If the unit includes an electric reheater, it will be set to full power. If the temperature continues to drop below the shutdown limit despite protection measures, the unit is switched to stop mode.

Note: A ventilation unit with a water coil must always be equipped with an external outdoor air duct damper. When the unit is in stop mode, external dampers are closed.

Note: If water is used in the cooling coil, a frost protection sensor must be installed and activated.

Heat Exchanger:

The unit features a defrosting function based on temperature and humidity. Defrosting is carried out by temporarily limiting airflow, allowing warm extract air to melt the frost in a controlled manner. Continuous ventilation in all conditions can be ensured by using a correctly sized duct-mounted preheater, available as an accessory.

Supply air temperature

If the supply air becomes too cold due to a fault, the unit is switched to stop mode.

The unit restarts automatically once the temperature has risen to a safe level.

Electrical heaters:

The heating elements are equipped with diagnostics that monitor their operation.

If the overheat protection trips repeatedly or does not reset, the heating is disabled, and power to the elements is cut off via the built-in relay.

Duct pressure control:

If duct pressure control is activated, the unit monitors pressure measurements. If no pressure signal is detected, a sensor alarm is triggered. During the sensor alarm, the fan is controlled with a fixed control signal defined during commissioning.

For fixed duct pressure control, it is also possible to enable a pressure deviation alarm, which activates if the duct pressure cannot be maintained for any reason.

SUUNN. XX	VERSIO.	2.16	DESCRIPTION SWEGON CASA Ventilation unit	R7/R7-H Genius	SUUNNITTELUALA, TYÖN JA PIIRUSTUKSEN N:O MUUTOS		
	PVM.	1.6.2026			LVI		
	ALLEKIRJOITUS				LEHTI	LEHDISTÄ 6 / 7	TILAAJAN N:O

DEVICE LIST Accessories

Device ID	Description
CO2	Carbon dioxide sensor, function: CO2 automation
VOC	VOC sensor, function: VOC automation
T6-T9	Temperature sensor. Connection to SET module. The sensor must be defined in the control panel.
SEM	Modbus extension module (includes 2 m RJ-45 cable)
SEC	IO extension module (includes 2 m RJ-45 cable)
SET	Connection module for duct heater actuators and temperature sensors (includes 2 × 3 m RJ-45 cables)
SDCW	Cooling coil for the supply air duct (includes SET, Power24VDC20W, three-way valve + actuator, duct coil, sensors)
SDHE	Electric heating coil for outdoor/supply air duct (includes SET, duct coil, sensors) Note! A duct filter (FLK) is required for the preheater.
SDHW	Heating coil for the supply air duct (includes SET, Power24VDC20W, three-way valve + actuator, duct coil, sensors)
SDHWM	Ground source duct coil for preheating/cooling in the outdoor air duct (includes SET, duct coil, sensor)
FLK	Duct filter for use with the electric preheater (SDHE)
SD1, SD2	Duct damper for outdoor air / exhaust air duct
S_PA,E_PA	Constant duct pressure control for supply / exhaust air duct. Note Power24VDC20W must be supplied separately.
GC10	Genius control panel, which can be connected via Wi-Fi to the Swegon CASA app.
GC04	Control switch for selecting boost, home, and away modes.
GC03	Control switch for selecting boost modes.
CH	Cooker hood. The CASA hood is connected to the ventilation unit with a modular cable. Other cooker hoods can control the cooker hood function via a switch input defined for this function.
SWITCH	Control switch, occupancy sensor, fireplace switch, and pressure switch for controlling various functions (Away, Boost, Fireplace, Stop functions)

	SUUNN.	VERSIO.	DEVICE LIST SWEGON CASA Accessories	R7/R7-H Genius	SUUNNITTELUALA, TYÖN JA PIIRUSTUKSEN N:O		MUUTOS
	XX	2.16			LVI		
	PVM.	1.6.2026			LEHTI	LEHDISTÄ	TILAAJAN N:O
	ALLEKIRJOITUS				7 / 7		

Functional diagram Room temperature control Fan Coil 2-Pipe system

24VAC Relay connection to SET and SEC/SEM module

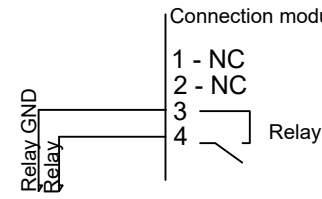

Season selection with external system

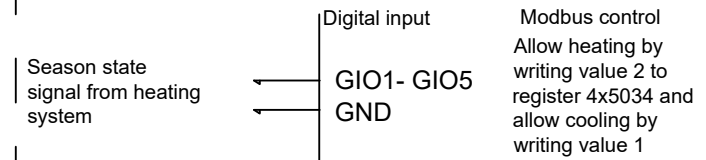

FAN COIL 1

Ilmanvaihtokoneen
kytkentäräjäpinta:
SET Moduli

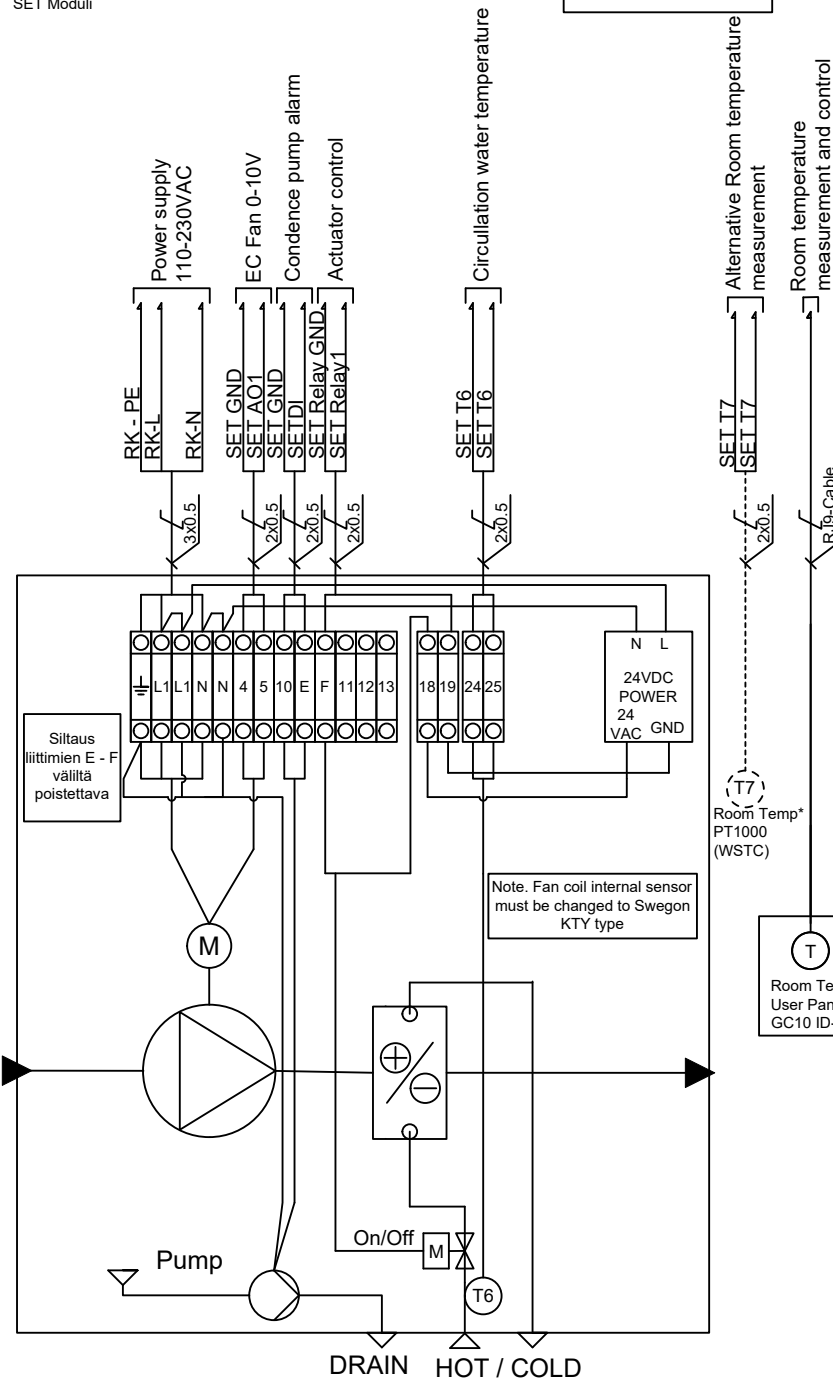

Note. Temperature sensor connection to SET Module requires sensor connector cable.

FAN COIL 2

Ilmanvaihtokoneen
kytkentäräjäpinta:
SET + SEC tai SEM Moduli

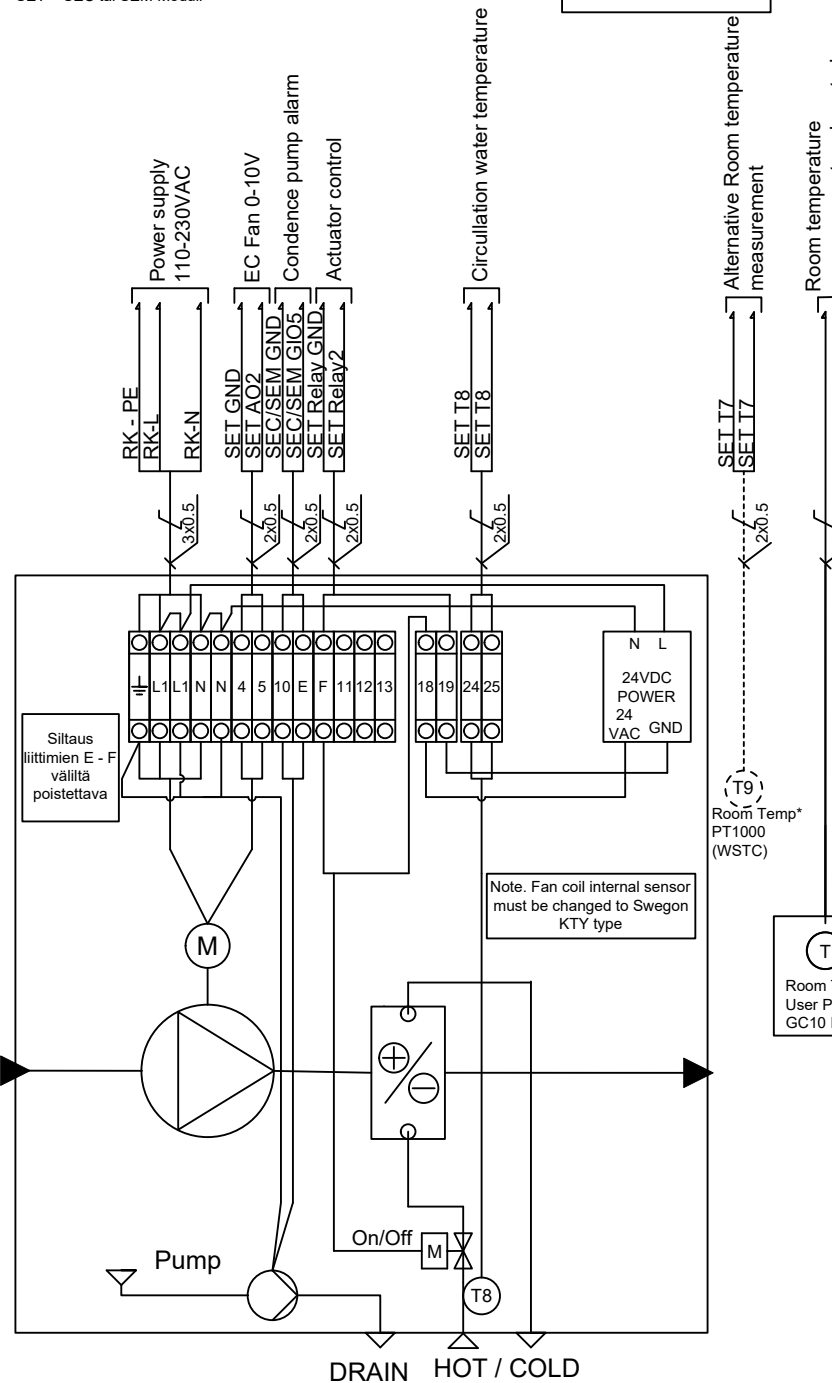

Note. Temperature sensor connection to SET Module requires sensor connector cable.

FAN COIL 3

Ilmanvaihtokoneen
kytkentäräjäpinta:
SET + SEM Moduli

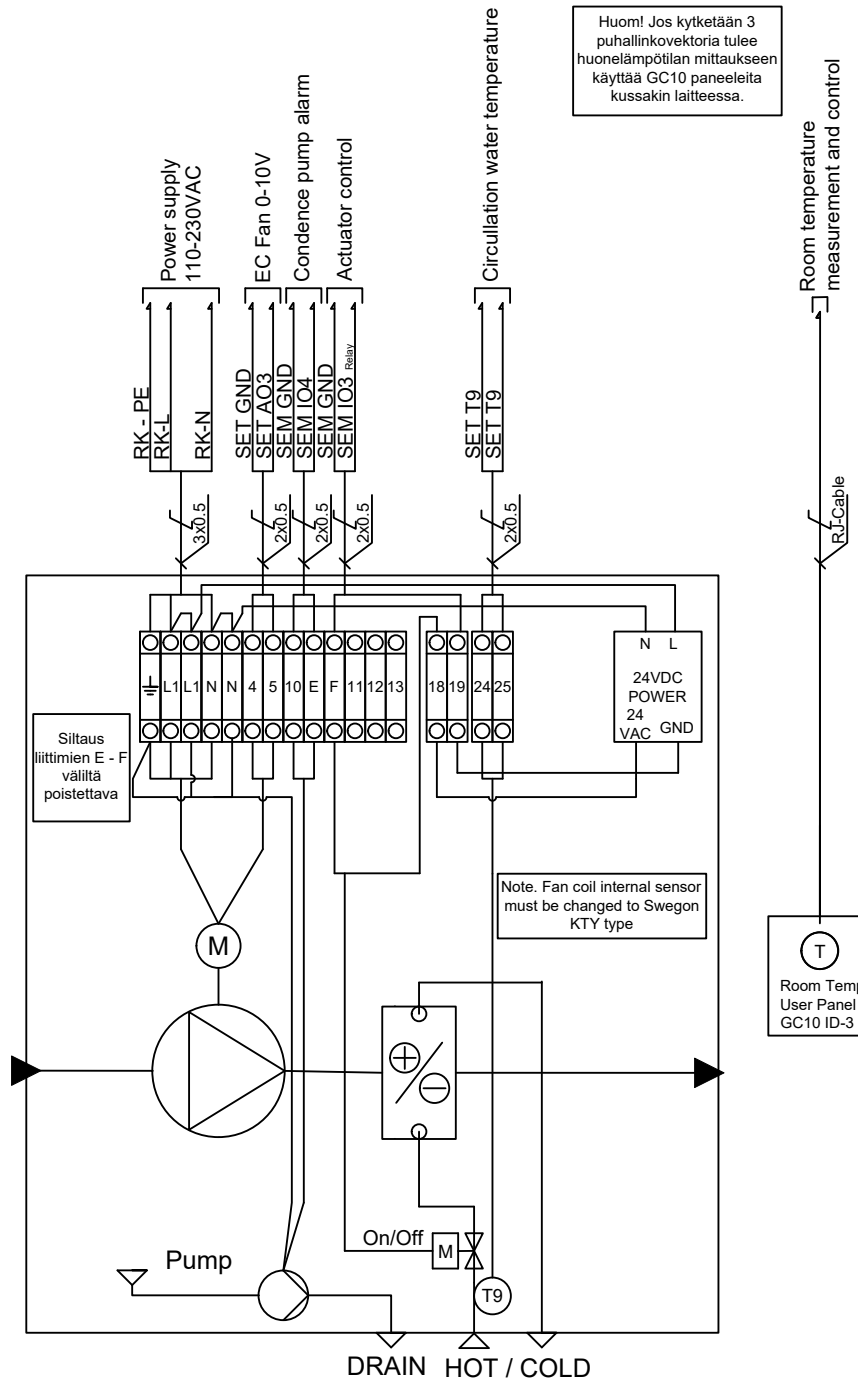

Note. Temperature sensor connection to SET Module requires sensor connector cable.

Huom! Jos kytketään 3 puhallinkonekvektoria tulee huonelämpötilan mittaukseen käyttää GC10 paneeleita kussakin laitteessa.

SUUNN.	VERSIO.
XX	2.16
PVM.	
1.6.2026	
ALLEKIRJOITUS	

DIAGRAM
SWEGON CASA
FAN COIL

SUUNNITTELUALA, TYÖN JA PIIRUSTUKSEN N:O		MUUTOS
LVI		
LEHTI	LEHDISTÄ	TILAAJAN N:O
	1 / 3	

Functional diagram Room temperature control

Fan Coil 4-Pipe system

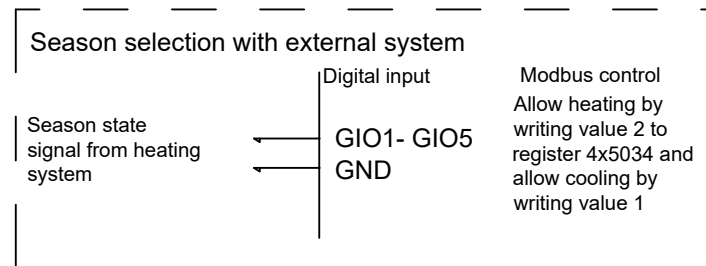
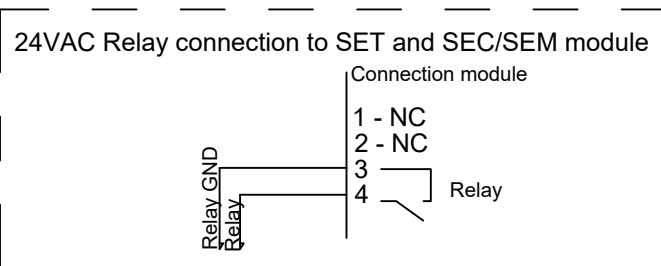

- ∟ Connection at site
- ∟∟ Cable changes at site
- * Alternative temperature measurement

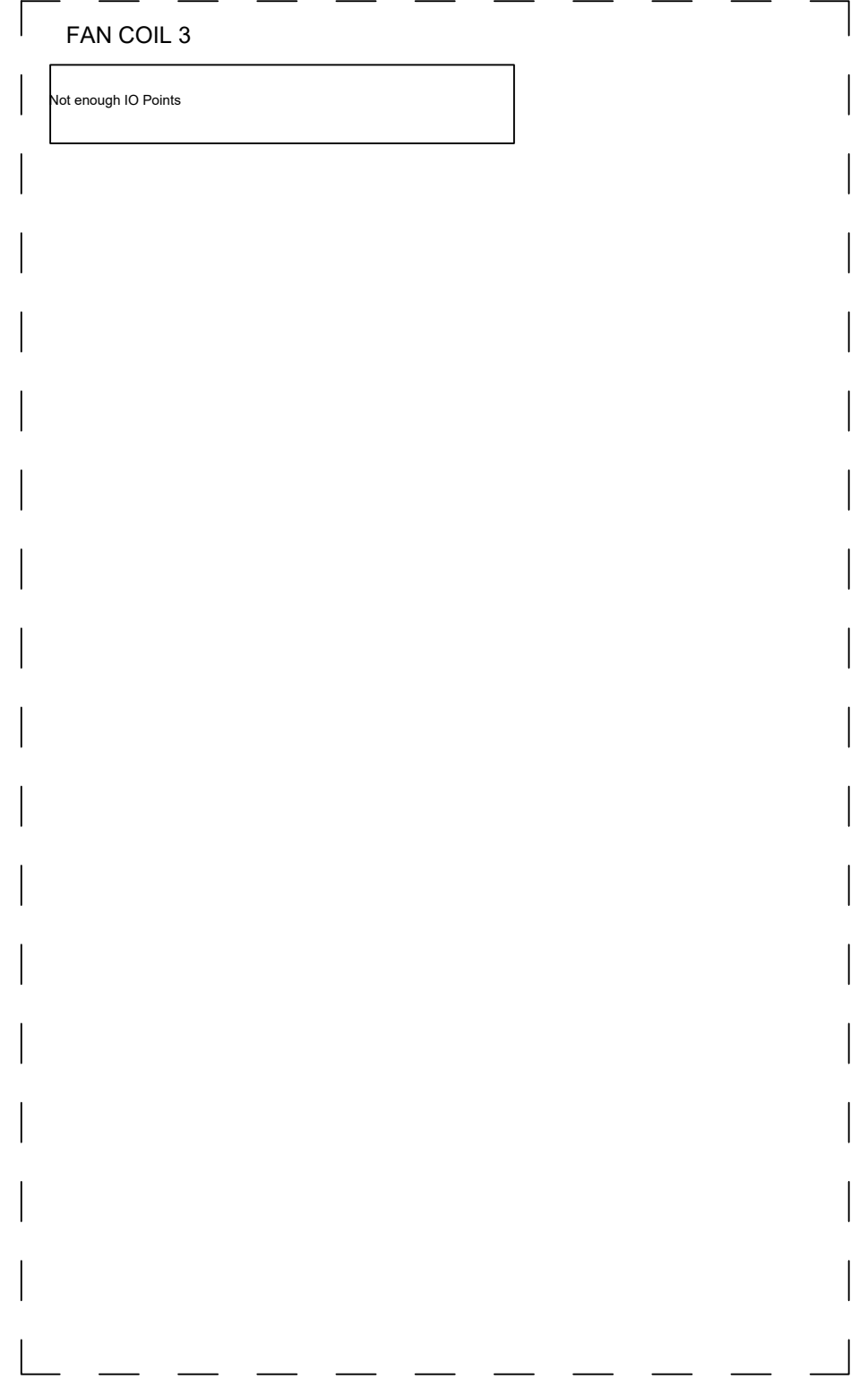
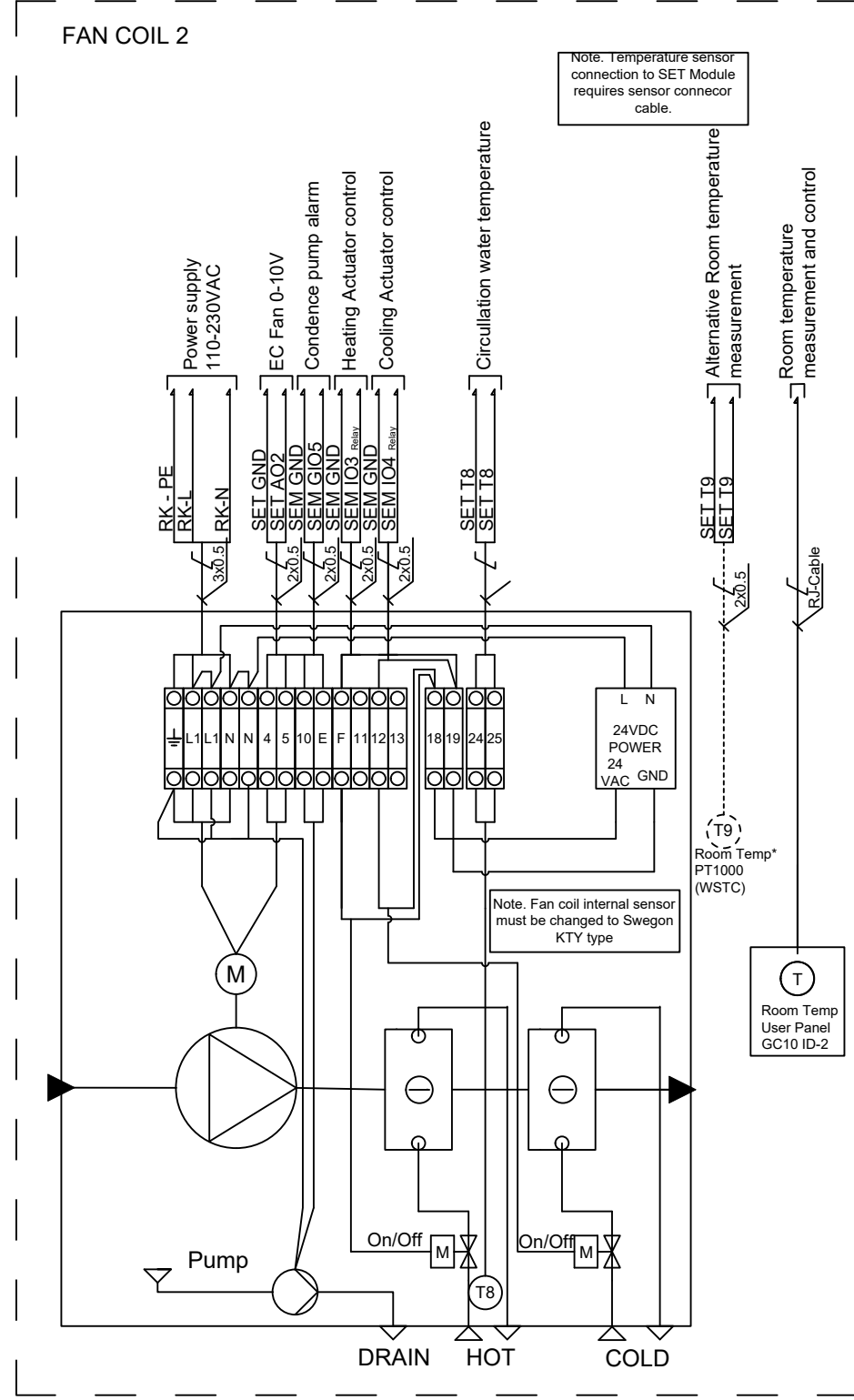
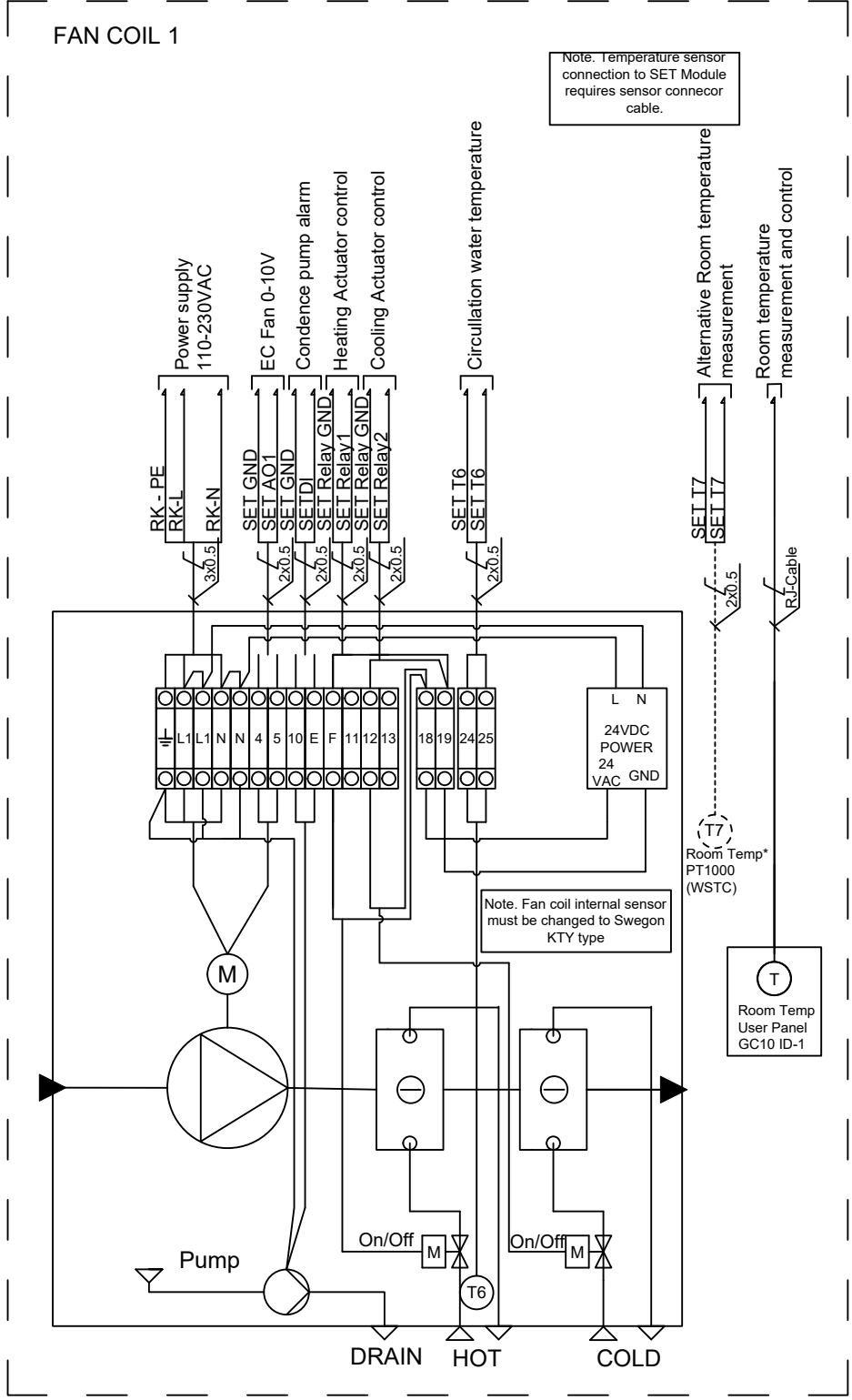

SUUNN.	VERSIO.
XX	2.16
PVM.	
1.6.2026	
ALLEKIRJOITUS	

DIAGRAM
SWEGON CASA
FAN COIL

SUUNNITTELUALA, TYÖN JA PIIRUSTUKSEN N:O		MUUTOS
LVI		
LEHTI	LEHDISTÄ	TILAAJAN N:O
	2 / 3	

Functional description room temperature controller

General

The room temperature control function of the air handling unit can control up to three room temperature controllers. The temperature controllers are independent of each other except for some common functions. The room temperature controller can control cooling, heating, or both, and additionally control the fan to boost cooling or heating as needed. Room temperature is measured using the CASA Genius control panel. The control panel can be set to room temperature controller mode, where only the setpoint, measured temperature, and related settings are visible. The panel can be locked into this mode with a password so the user cannot access other settings. During cooling season, temperature increase can be selected, and during heating season, temperature decrease can be selected when the air handling unit is in away mode. This helps save energy by changing the unit's mode as needed. This can also be automated, for example, with the CO₂ function.

Connection interface of the air handling unit

For room temperature control, a maximum of 4 pcs 0–10 V outputs, 2+5 pcs relay outputs, and 1+5 pcs digital inputs are available. Note that 5 of the outputs/inputs are configurable, so the number depends on configuration. The connection diagrams show examples, but each I/O must be defined during commissioning, where their location can also be changed.

Actuators of the room temperature controller

The room temperature controller controls a heating/cooling actuator. The actuator can be ON/OFF or PWM type, in which case control is via an intermediate relay. (Note: when using PWM control, observe the maximum switching frequency of the relay.) The actuator can also be controlled with a 0–10 V control signal (min and max voltages adjustable).

The actuator can control heating, cooling, or both in 2-pipe systems. Alternatively, it can control both heating and cooling in 4-pipe systems, in which case two actuators are controlled.

By default, the system measures circulation water temperature, allowing heating or cooling when the water temperature exceeds/falls below the heating and cooling set limits (adjustable). Note: in 4-pipe systems only the hot water circulation temperature is measured, so the cooling limit must be set high enough to activate cooling regardless of hot water temperature.

Fan control

Fan control is via a 0–10 V control signal. Min and max voltages can be set, as well as a neutral-state control voltage when neither heating nor cooling is active.

When heating or cooling is active, fan speed is boosted according to the room temperature controller's demand. A boost threshold can be set, defining when the fan starts boosting. For example, with a threshold of 20%, the controller operates the actuator 0–20% with the fan at minimum speed. When the output exceeds 20%, the fan starts boosting so that when the controller output reaches 100%, the fan also runs at set maximum speed.

The user can influence fan speed by selecting a silent mode, limiting fan speed to minimum. This is available only for a limited time (max. 6h). The user can also select a boost mode (active 2h), in which case the fan runs at maximum speed regardless of temperatures – useful for passive cooling/ventilation.

Cooling / Heating season selection

Season selection can be made automatically by measuring circulation water temperature. After detecting heating or cooling demand, the valve is fully opened, and then the system waits until the water temperature exceeds/falls below the set threshold. If insufficient, the valve closes and a 2h delay occurs before repeating the test.

If no water temperature measurement is available, the selection can be made via an I/O input or controlled via Modbus RTU.

Season selection can also be made from the control panel, allowing manual activation of heating or cooling.

Room temperature controller

Room temperature is regulated by a PI controller, measuring with the CASA Genius panel, a separate wall-mounted PT1000 sensor, or an internal Swegon PTC sensor.

The setpoint can be selected from the panel. The user-selectable range can be limited at commissioning (+18 C ... +25 C). Setpoint adjustment can also be limited when the unit is in Away or Travel modes by defining an increase/decrease offset (default 0 °C). Controller response can be tuned in the commissioning menu (P-gain and I-time).

Diagnostics

The controller operation can be monitored via the panel's diagnostics menu or Swegon CASA APP, where room temperature trend data is visible.

Alarms

Condensation alarm (cooling coils only): A digital input can be assigned to condensation function. When activated, cooling is stopped. If active for 2h, a condensation risk alarm is shown on the panel.

Circulation water temperature alarm: When the sensor is in use, an alarm is triggered if water temperature is insufficient within 5min.

Switching the control panel to room control mode

The control panel can be switched to room control mode after commissioning. Note: the control panel installed in the room must be connected and assigned a unique ID in the panel settings. During commissioning, select the panel defined as the room temperature measurement source.

To enable room control mode, the panel user level must be set to "Extended" (modifiable in commissioning menu). Room control mode can then be selected from the main view. One of up to three room controllers or ventilation can be chosen. Once selected, the visible functions can be configured for the user. These can then be locked via the commissioning menu by switching the user level to "Basic".

	SUUNN.	VERSIO.	DESCRIPTION SWEGON CASA FAN COIL	SUUNNITTELUALA, TYÖN JA PIIRUSTUKSEN N:O		MUUTOS
	XX	2.16		LVI		
	PVM.	1.6.2026		LEHTI	LEHDISTÄ	TILAAJAN N:O
	ALLEKIRJOITUS			3 / 3		