

CASA R5-H Genius

Technical catalogue

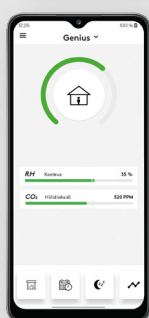

QUICK FACTS

- Can be mounted on the wall or floor
- Wall mounting bracket and the floor mounting base available as accessories
- Control from the control panel and mobile app
- Can be connected to building automation systems (Modbus)
- Demand-based control of air flows (RH, CO₂, VOC*)
- Stepless supply air temperature control
- Automatic summer and winter function

UNIT TECHNICAL CONTENT

Air flow range	30-130 l/s 108-468 m ³ /h
Dimensions, w x l x h	702 x 479 x 613 mm
Duct outlets	4 x Ø 160 mm
Energy calculations and acoustic data	procasa.swegon.com
Connection power	250 W 950 W
Power connection	230 V, 50 Hz, 10 A
Fans	230 W, EC
Filters	ISO ePM1 50% (F7) filters for supply air and extract air
Colour	Exterior White, RAL 9016 (corresponds to NCS S0502-G50Y)

Content

Technical description	3
CASA Genius control	6
Design data	8
Air flows	10
Acoustic data	10
Dimensions and weight	11
Functional diagram	12
External connections	14
Internal connections.....	15
Installation options	16
Product codes	18



Technical description

Swegon CASA R5-H Genius

The R5-H is a horizontal ventilation unit that is suitable for ventilation in large apartments, offices or conference rooms.

The ventilation unit is controlled from the control panel and via a mobile app (iOS/Android) and can be connected to building automation systems using Modbus.

The unit is Eurovent certified and has a third-party certified EPD environmental declaration and LCA life cycle assessment.

Indoor environmental quality

Ventilation control

The unit is controlled steplessly with automation functions to guarantee the best indoor environmental quality. The user can select five operating modes home, away, boost, travelling and home+ by using control panel, cooker hood or Swegon CASA app. Operation modes can be automated with unit's weekly programs.

Temperature control

The supply air temperature is controlled with heat exchanger and if needed with optional heating or cooling element.

The unit has automatic summer time detection. The function sets lower supply air temperature setpoint and boost ventilation in order to bring more fresh outdoor air to the apartment during summer nights.

Available variants

Standard units are available in following variants:

- Unit with out postheater
- Unit with 700 W postheater

Components

Fans

CASA R5-H is equipped with energy efficient EC fans.

Filter

The ventilation unit is equipped with ISO ePM1 50% (F7) filters for supply air and extract air. The need of filter replacement is indicated on the control panel and on the CASA cooker hood.

Heat exchanger

The ventilation unit is equipped with a **speed controlled rotary heat exchanger**. Heat exchanger is controlled either to maintain constant supply air temperature or to achieve maximum energy efficiency (winter mode).

External connections

All connections can be made without opening the electrical box. Plug-in modules are available for external connections. Wide variety of IO functions are available.

The ventilation unit is equipped with In-build Modbus. Modbus cabling can be made easily with external cable (SEC) or module (SEM). Unit can be fully controlled with Modbus and all external IO's can be configured to Modbus usage.

Protective functions

The heat exchanger freeze protection

The defrosting function guarantees continuous ventilation and maintains units performance even during extreme conditions. If reheat can't maintain sufficient supply air temperature, the air flows are reduced.

The fan overheating protection

The fan overheat protection stops the fan if the temperature rises too high and is reseted automatically. If protection stops the fans an alarm is generated.

Rotor guard

Rotor guard detects that the rotor is working. Malfunction generates an alarm.

Cold supply air

The ventilation unit has built-in condensation protection. If the supply air is too cold, the ventilation unit stops and an alarm is generated

High temperature

If supply air or units internal temperature is detected dangerously high the unit is stopped and an alarm is generated.

Temperature sensors

If a sensor fault is detected, an alarm is generated. If the faulted sensor is critical the ventilation unit is stopped. The ventilation unit returns to normal mode once the fault has been corrected.

The delivery includes

- Ventilation unit
- Quick Guide
- Installation and commissioning instruction
- Product fiche

Standard connections

- Power cord with earthed plug (2 m)
- Modular cable with RJ9 connector (1.5 m)
- Freely configurable I/O contacts for connection of accessories (2 pcs.)

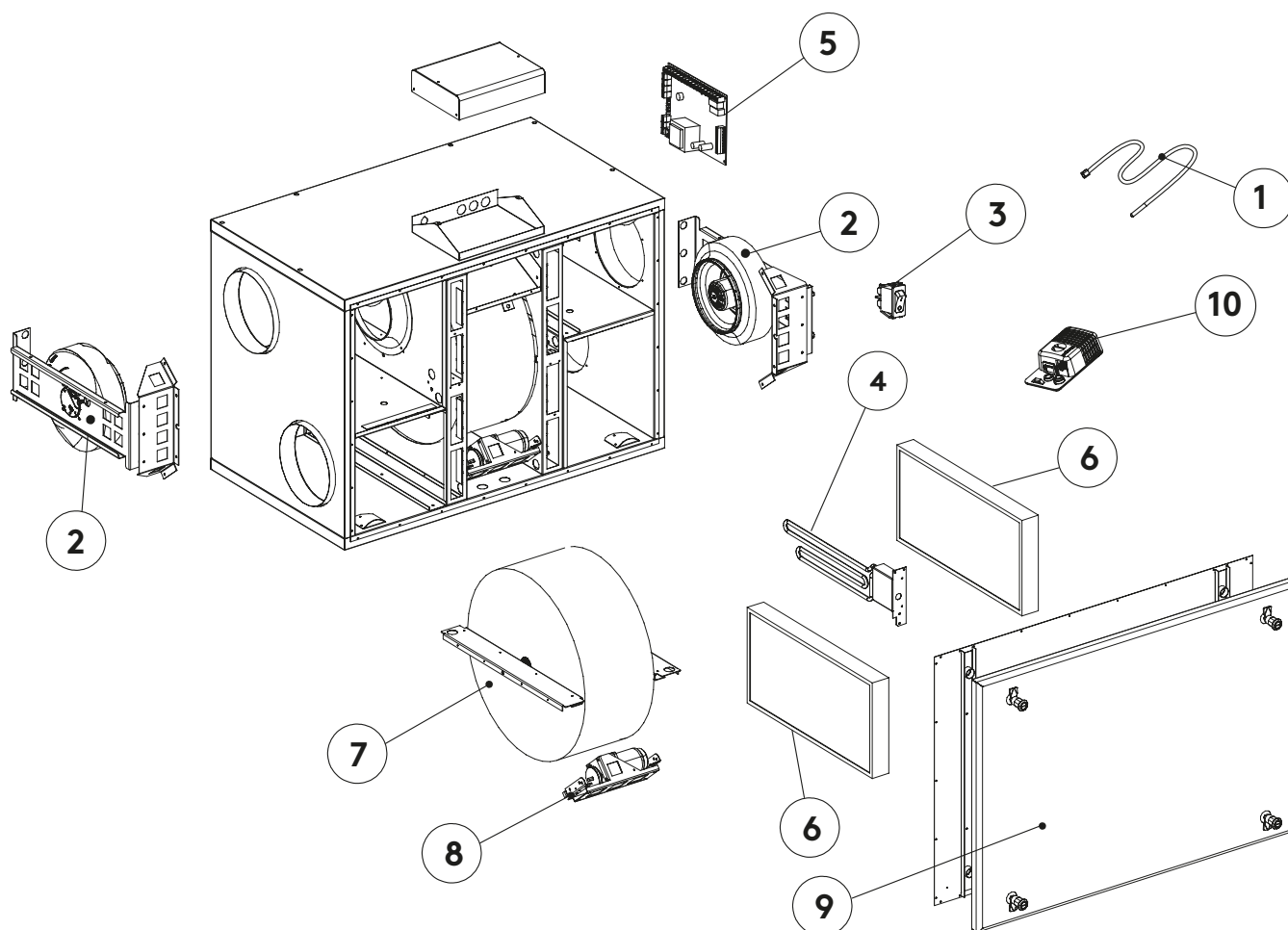

1. Temperature sensor
2. Fan
3. Operating switch
4. Reheating module 700 W (optional)
5. Genius control board
6. ISO ePM1 50% (F7) filters
7. Rotor
8. Rotor motor
9. Door
10. Sensor package, RH + CO₂



Swegon CASA Genius

Intelligent control of the ventilation

With Swegon CASA Genius residents can monitor the indoor air quality (RH, CO₂, VOC, °C), adjust ventilation to their wishes or let the intelligent control to adjust ventilation automatically while saving energy and providing fresh and healthy indoor air.



The Swegon CASA control panel (GC10)

Wall-mounted touch screen for external or flush mounting. From the touch screen user can monitor ventilation, change ventilation mode, change the settings and commission the ventilation unit. The screen can be connected to the home WLAN, enabling the ventilation to be controlled remotely from a Swegon CASA mobile app



The Swegon CASA app

With Swegon CASA app residents can use all the control functions remotely from their own smartphone. Users get more information about their home's air quality as well as valuable instructions and advice about the ventilation (requires Swegon Genius control panel).



The CASA Service app

for quick and easy commissioning. The app works locally together with the ventilation unit and doesn't require connection to network. The app defines the I/O connections, presets the fan speeds that correspond to specified air volumes, as well as automatically sets air volumes for home and boost mode. Finished settings can be saved in the app and copied to the next apartment (requires Swegon Genius control panel).



Swegon CASA cooker hood

With cooker hoods, it is possible to control the ventilation unit's operating mode (home, away, boost), the cooker hood's shut-off damper and the lighting in the hood. The system balances the ventilation automatically when using the cooker hood.



The Swegon CASA HOME/AWAY/BOOST control switch (GC04)

Wall-mounted control switch for selecting boost, home and away modes.



Home automation

Can be connected to the home automation for centralised monitoring and control, either directly via configurable I/O or with the aid of a separate Modbus connection module (SEM).

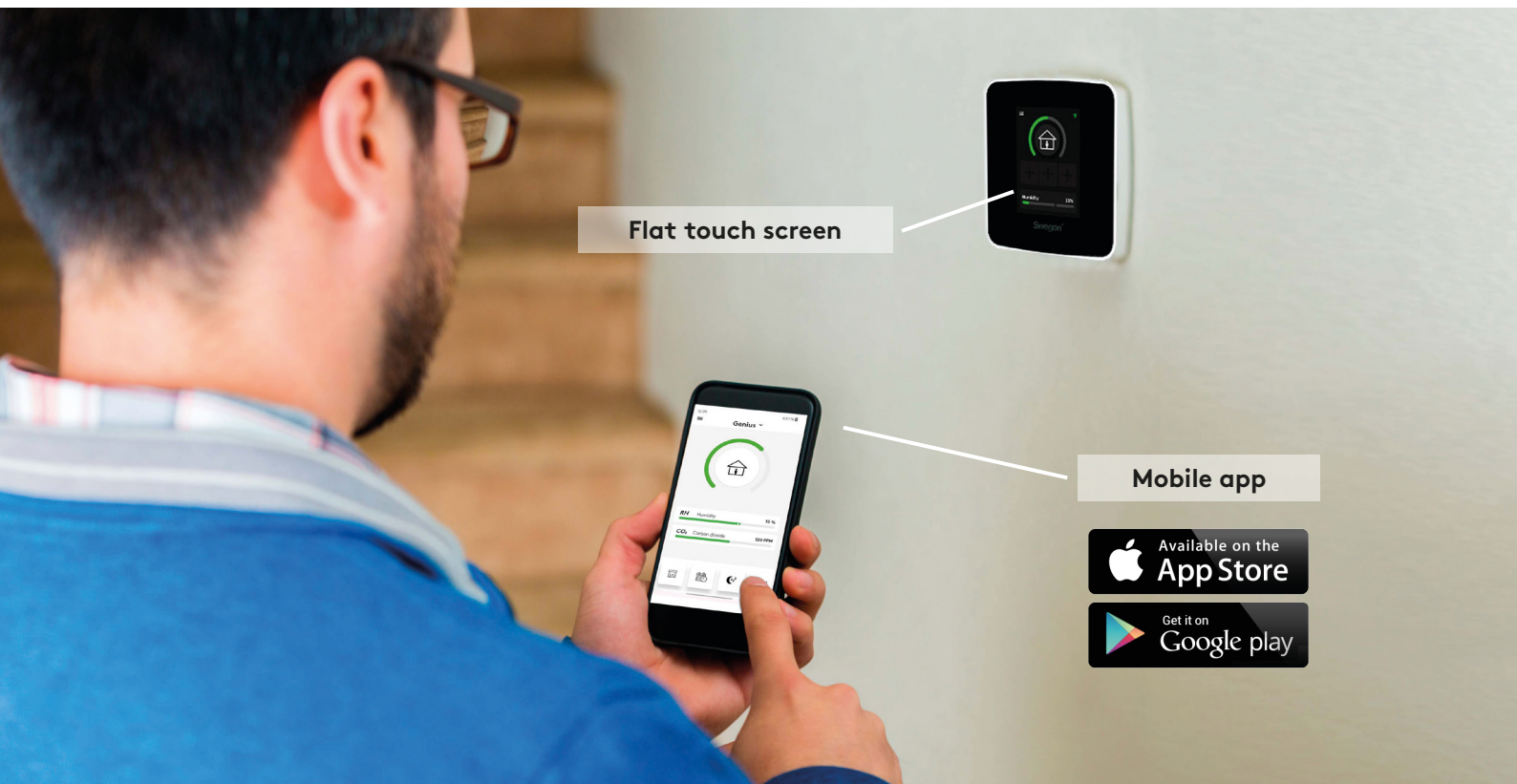

Flat touch screen

Mobile app





Basic modes

You can switch as required to an appropriate operating mode or let the pre-programmed weekly clock switch operating mode according to the diurnal rhythm you want.



Home

Normal air flow. Sufficient amount of fresh indoor air to ensure the wellbeing of the residents and the structural building elements when there are people in the home.



Home+

Higher air flow. Can be used when more ventilation is required. The home owner can change the efficiency of the operating mode from the settings.



Boost

High air flow. Used if the ventilation requirement increases, for example, when cooking, taking a bath or drying laundry, or when an unusually large number of people are in the home.



Away

Low air flow. Reduces the energy consumption when nobody is present in the home.



Travelling

Very low air flow and lower supply air temperature. Used when nobody is present in the home.

Automatic functions

The intelligent ventilation monitors the quality of the indoor air and adjusts the ventilation automatically.



RH Humidity 35%



Automatic RH system included as standard

Humidity automation removes damaging moisture. The intelligent control analyses the indoor air continuously and regulates the ventilation steplessly so that excess moisture is removed, for example when you are washing.



CO₂ Carbon dioxide 520 PPM



Automatic CO₂ system as optional equipment

Automatically lowers the ventilation and saves energy when nobody is in the home. When the residents are at home, the ventilation is automatically boosted to bring exactly the right amount of fresh air into the home.



VOC Air quality 950 PPM



Automatic VOC system as optional equipment

The automatic air quality system boosts the ventilation if pollution, odours or vapours (evaporating organic compounds) are detected in the indoor air.



Swegon CASA -liesikuvulta
voi ohjata ilmanvaihtoa



Design data

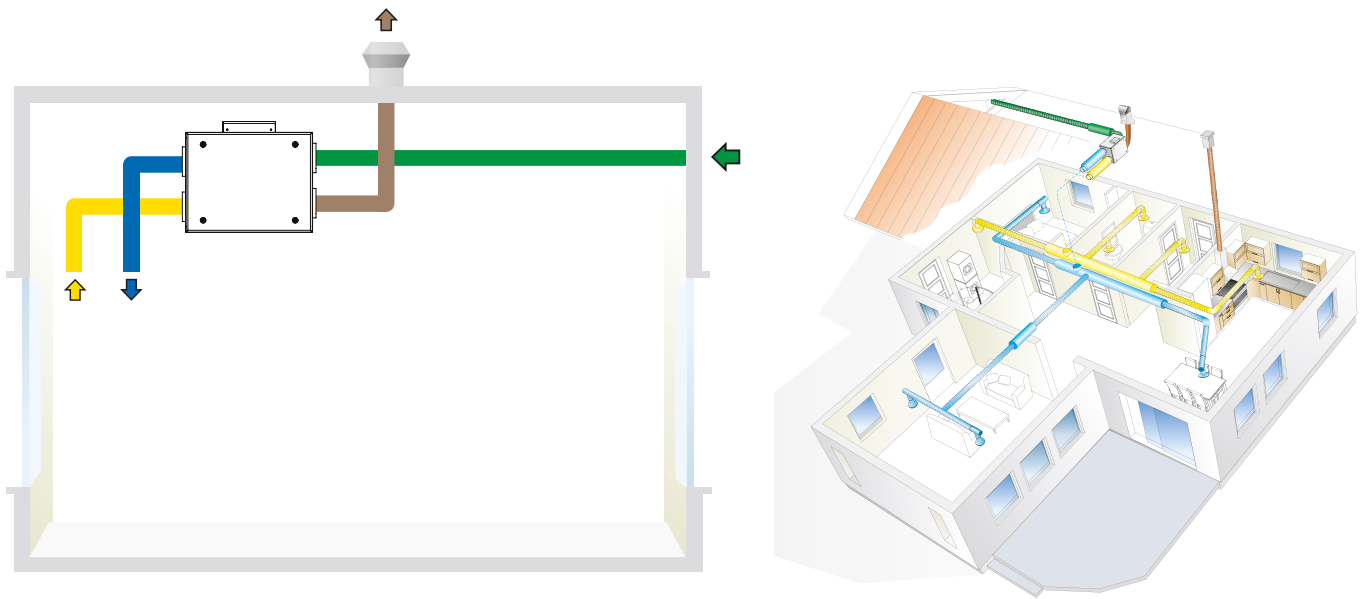

Outdoor air



Supply air



Extract air



Exhaust air

*The ventilation unit has been supplied in the left-hand version (L) and it can be changed to right-hand version (R) on site.
Note! Always check the correct duct sequence in the installation instructions.*

ProCASA®

Energy calculation, functional diagram and acoustic data on ProCASA.

procasa.swegon.com

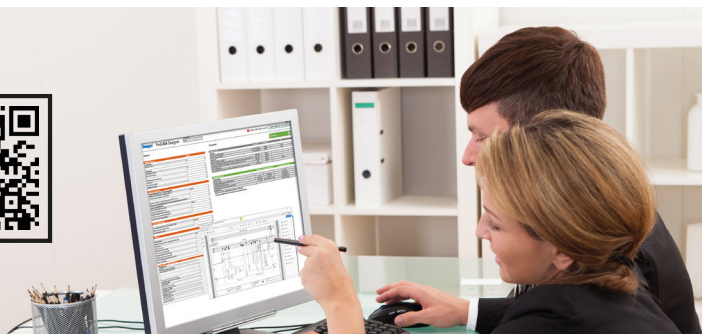

Energy calculator

Select area: FIN - Vantaa

24.0°C ... 20.0°C
Data from TRV 2020

Make calculation for commercial building (B01)?
Include Finnish regulation?

Select and print pages:
 Energy calculation and dimensions

Project: []
Customer: []
Designed by: []
Location: []

Default values: I/s

Air flow: Supply air 50 l/s, Extract air 50 l/s
Duct pressure: 80 Pa, 80 Pa
Cooker hood airflow: 0 l/s
usage time per day: 0 h/d

Indoor temperature 21°C
Minimum supply air temperature (+10°C...-12°C): -10, -11, -12, -13, -14, -15, -16, -17, -18, -19, -20, -21

Eco-Design requirements:
SEC class: A
SEC cold / average / warm climates: A
Max airflow rate: 337 (m³/h)
Sound power level: 39 (dB(A))

This unit can be equipped with:
 Clock control*
 Central demand control*
 Local demand control*

Fan power and energy use EN13141-7

Supply air	31 W
Extract air	27 W
SFP	0.34 W / (m³/s)
SFP	1.16 kW / (m³/s)
Annual energy use of fans	508 kWh

Energy used to heat the air EN13141-7

Preheating	0 kWh
Reheating to 17 °C	237 kWh
447W peak load	
Heating the supply air to 21 °C	1243 kWh
Heating the infiltrated air to 21 °C	0 kWh
Energy used to heat up ventilated air to 21°C	1481 kWh
Energy used without heat recovery	714 kWh
Annual energy efficiency for room (21°C)	79 %
Heating the infiltrated air to 17 °C	0 kWh
Energy used to heat up ventilated air to 17 °C	237 kWh
Annual energy efficiency for AHU (17 °C)	97 %
Temperature efficiency of heat exchanger	82 %
Temperature efficiency of air handling unit	80 %

Acoustic data

Octave band (Hz)	63	125	250	500	1k	2k	4k	8k	L _{max}
	L _w	L _w	L _w	L _w	L _w	L _w	L _w	L _w	L _{max}
supply air duct	68	69	68	57	52	49	44	37	62
return air duct	60	63	61	45	34	33	21	19	54
outdoor air duct	60	63	62	47	35	31	21	18	55
exhaust air duct	67	68	68	56	52	48	43	36	62
kitchen bypass duct									
surroundings	50	44	45	37	28	19	12	11	39
surroundings at -4dB sound attenuation									L _{pa} dB(A) 35

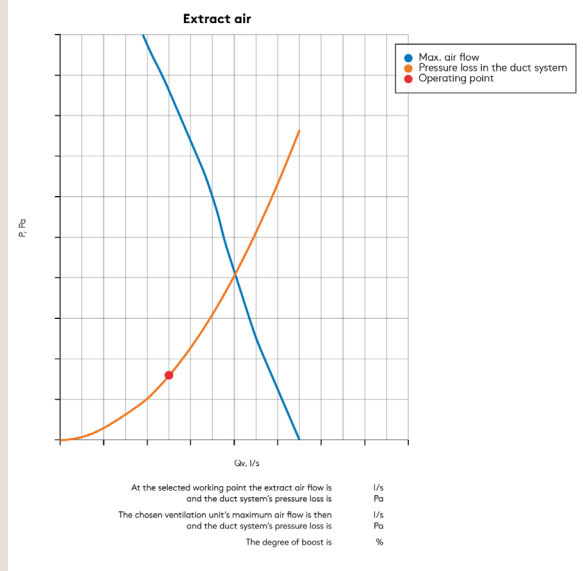
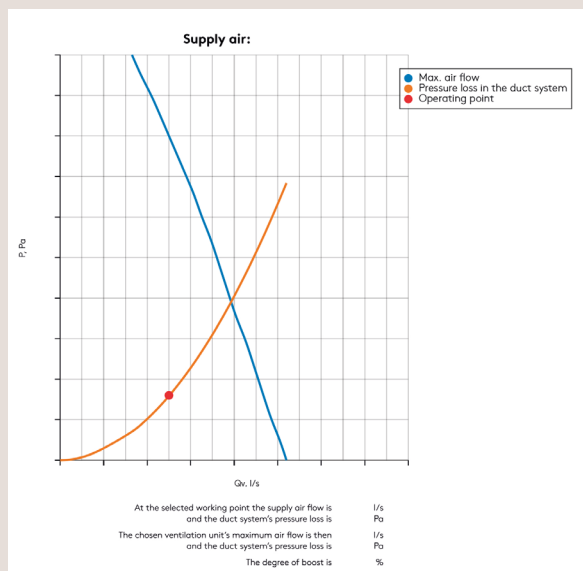

3D models and CAD dimension sketches for all Swegon CASA products are available from MagiCloud. You can download DXF files directly from MagiCloud or use a MagiCAD plugin to transfer dimension sketches to the Revit and AutoCAD software packages.

www.magicloud.com



Air flows

Air flows EN 13141-4

R5-H

- Supply airflow
- - - Extract airflow

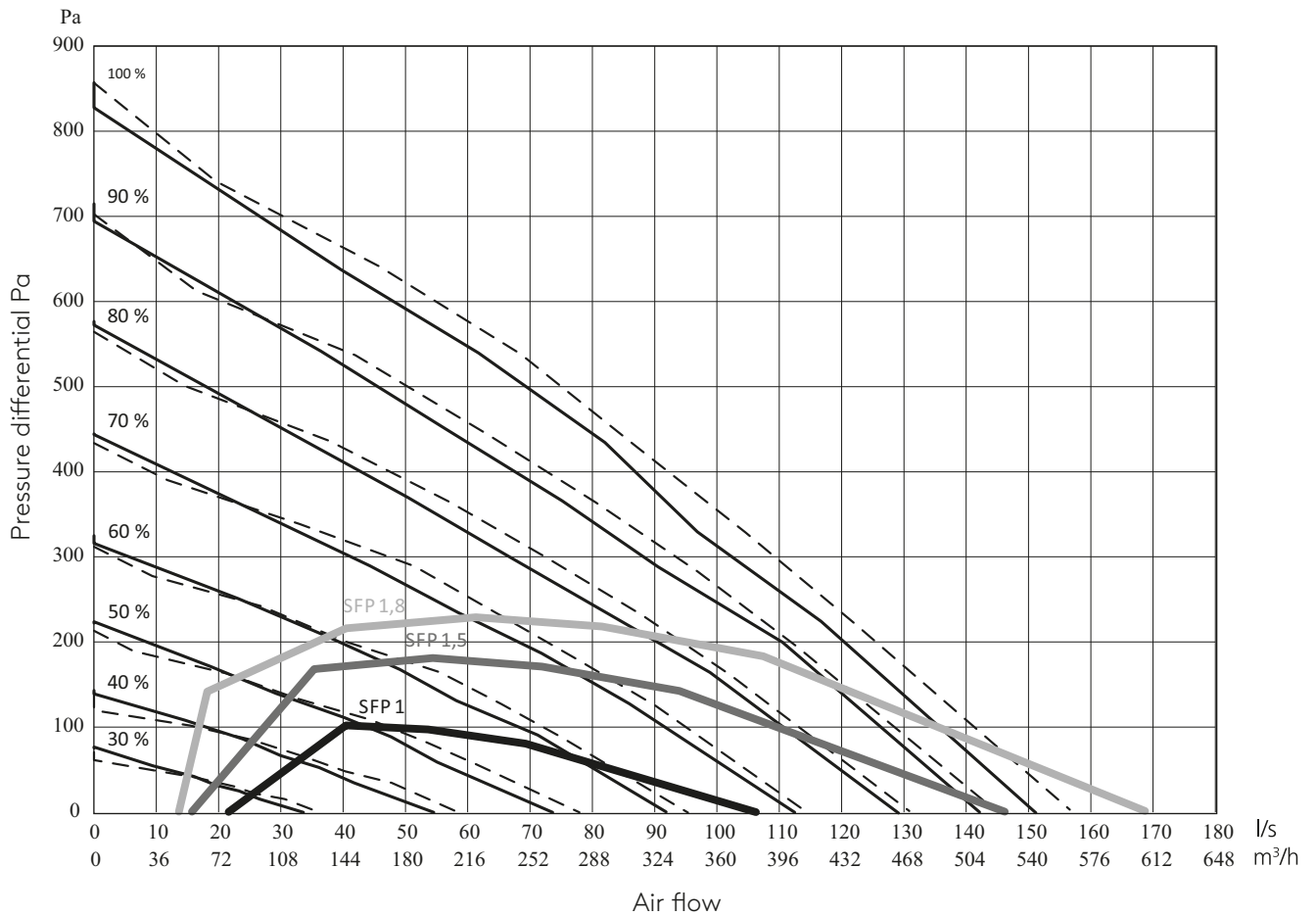

Acoustic data

See acoustic data on ProCASA.

procasa.swegon.com





Dimensions and weight

Dimensions

R5-H

Weight of the unit: **53 kg**

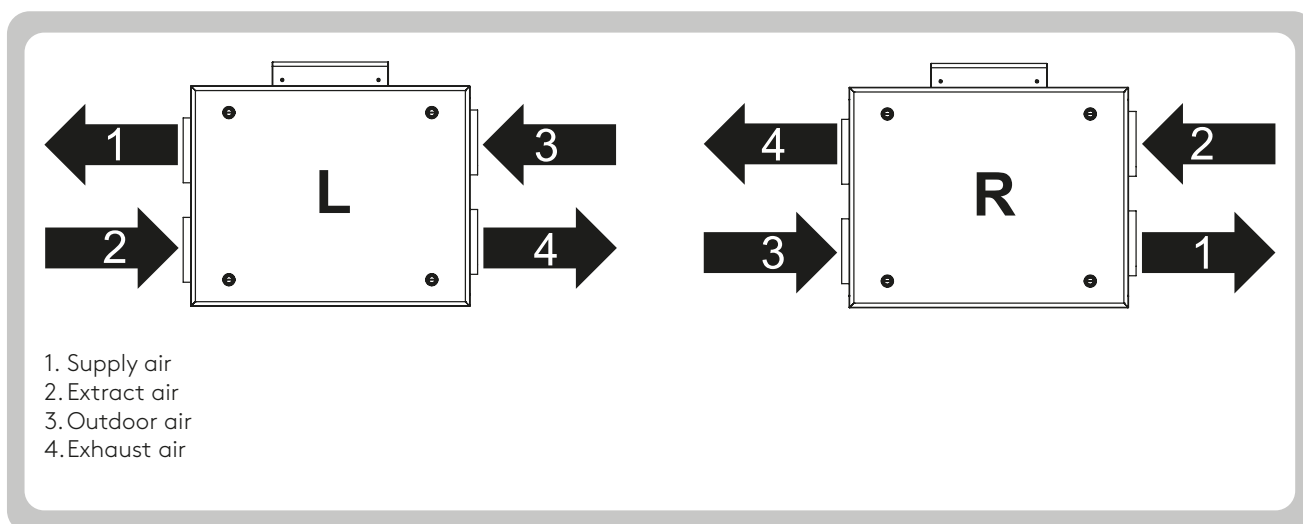
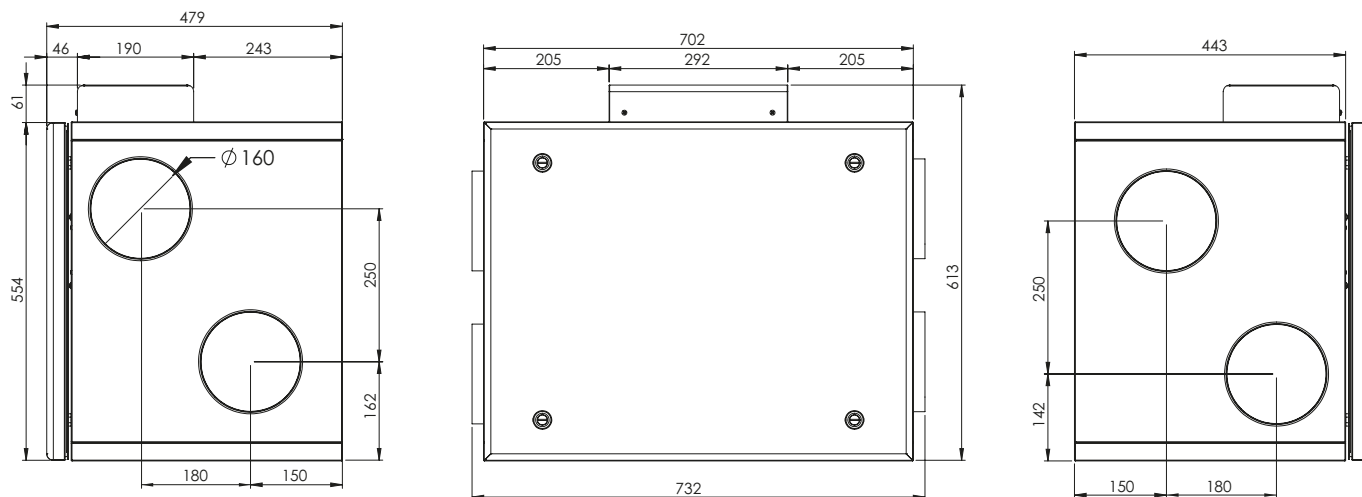



Functional diagram

Functional diagram

R5-H

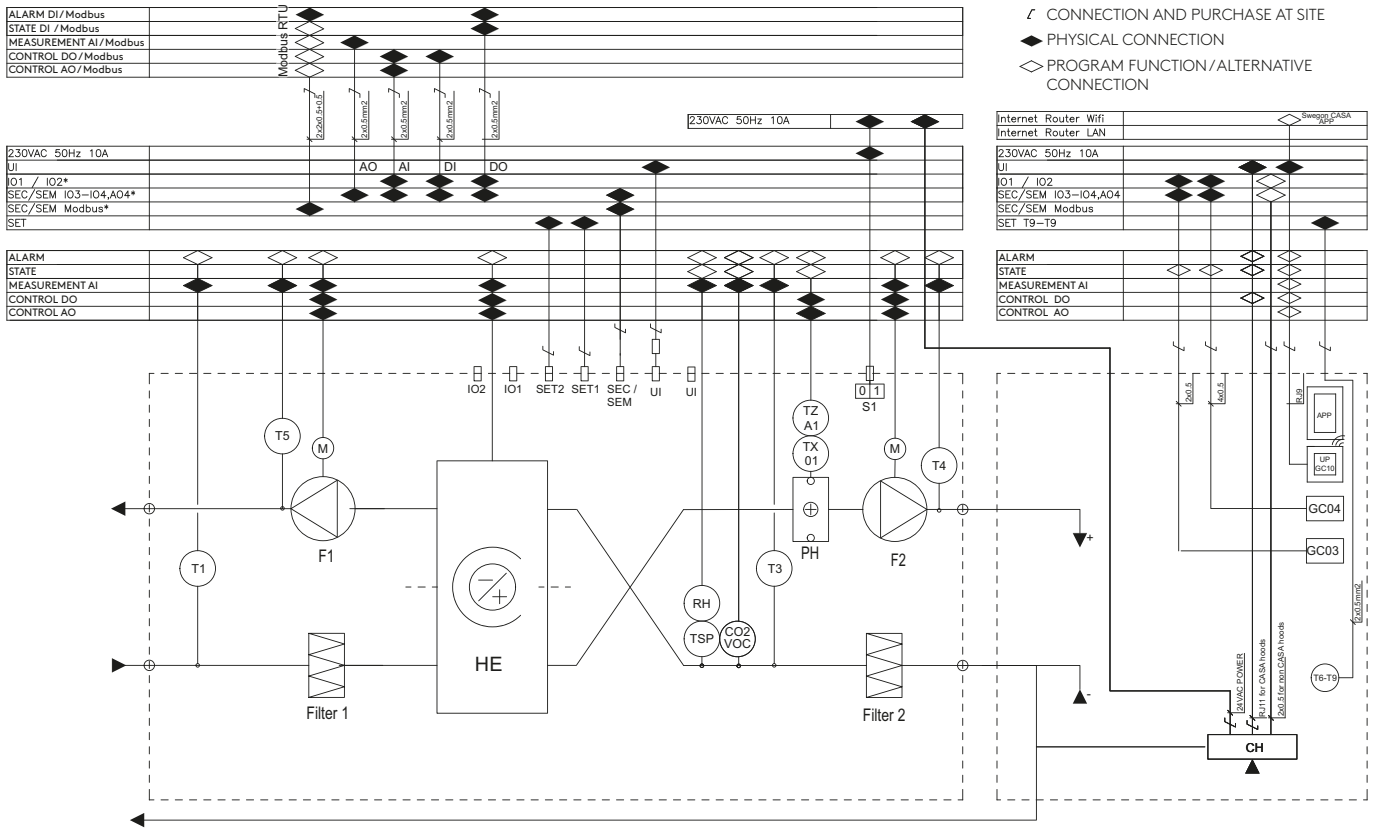

Device	Description	Modbus register
T1	L: Temperature sensor, outdoor air R: Temperature sensor, extract air	3x6201 (0,1°C)
T3 TSP	L: Temperature sensor, extract air R: Temperature sensor, outdoor air	3x6204 (0,1°C)
T4	L: Temperature sensor, supply air R: Temperature sensor, exhaust air	3x6203 (0,1°C)
T5	L: Temperature sensor, exhaust air R: Temperature sensor, supply air	3x6205 (0,1°C)
TZ01	Manual overhear protection 60°C post heater	Alarm 3x6117
TZA1	Automatic overhear protection 50°C post heater	Alarm 3x6117
Filter 1	Air filter ISO ePM1 50% (F7)	Service reminder info 3x6129
Filter 2	Air filter ISO ePM1 50% (F7)	Service reminder info 3x6129
F1	L: Extract fan R: Supply fan	Control 3x6304(%), RPM 3x6306
F2	L: Supply fan R: Extract fan	Control 3x6303(%), RPM 3x6305
PH	Post heater (1400W), controlled steplessly according to demand (optional)	Control 3x6317 (%)
HE	Rotating heat exchanger (Rotor)	
HE M	A heat exchanger motor which speed is steplessly controlled based on the temperature and humidity of the supply air	Control 3x6332 (0.1xRPM)
S1	Use Switch. Note! power off the unit by removing the socket from the Mains when Service	
RH	Humidity sensor for RH automation	RH 3x6214

Functional diagram Duct actuators

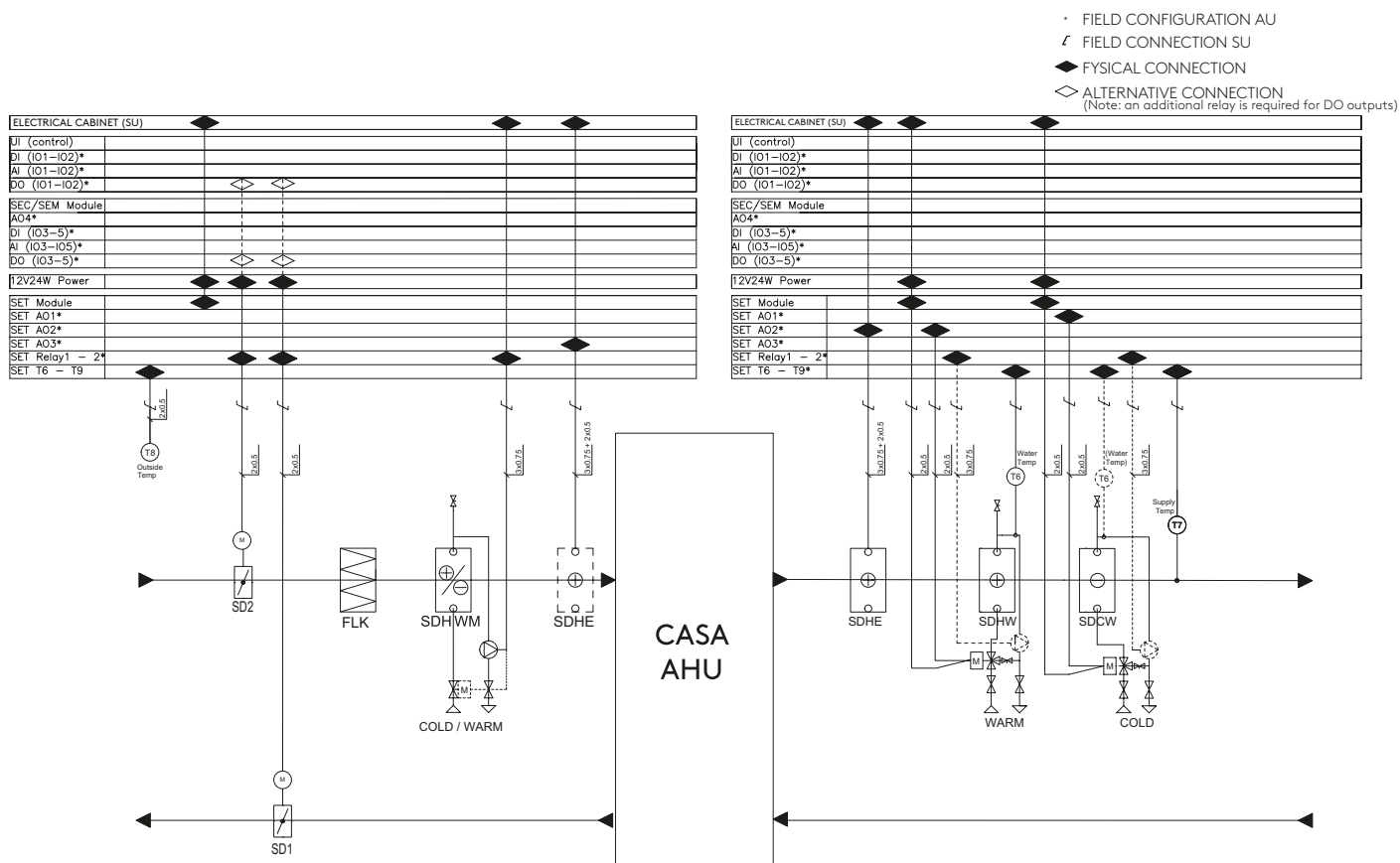

Device	Description
T6-T9	Temperature sensor. Connection to the SET module. The sensor must be defined on the control panel.
SD1, SD2	Duct Plate for Outdoor/Exhaust duct.
FLK	Duct filter in combination with an electric pre heater (SDHE)
SDHWM	Ground Liquid preheating/cooling coil for outdoor air duct. (Inc SET, heating/cooling coil, sensor)
SDHE	Electrical duct heater for Supply/Outdoor air duct (Inc. SET, duct heater and sensors) Note! A duct filter (FLK) is required for the preheater.
SDHW	Heating coil for supply air duct (Inc. SET, three-way valve + actuator, heating coil, sensors).
SDCW	Cooling coil for supply air duct (Inc. SET, three-way valve + actuator, cooling coil, sensors).
CO2	CO2 sensor for CO2 automation
VOC	VOC sensor for VOC automation
SEM	Modbus module (Inc. 2m RJ-45 cable)
SEC	IO extension module (Inc. 2m RJ-45 cable)
SET	Connection module for duct batteries and temperature sensors. (Inc. 2 x 3m RJ-45 cable)
APP	Swegon CASA mobile application for ventilation control and monitoring. Requires a Genius control panel (GC10) to operate.
UP GC10	Genius control panel that can be connected to Swegon CASA application via WiFi.
GC04	Control switch to select boost, home and away mode.
GC03	Control switch to select boost mode.
CH	Cooker hood. The CASA hood is connected to the ventilation unit with a modular cable. With other hoods, you can control the cooking function with a switch input that is determined for the function.



External connections

External connections CASA Genius

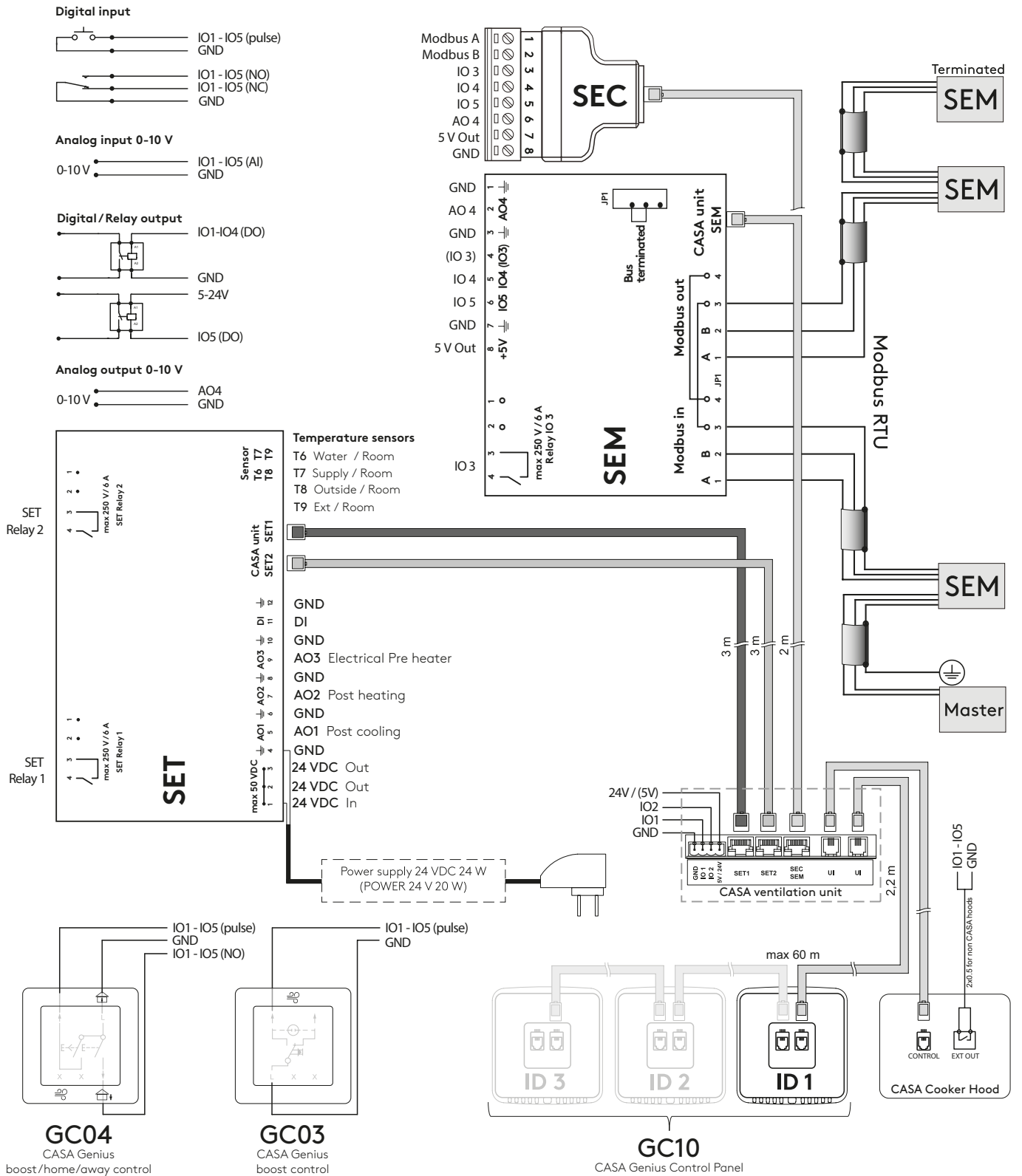

- SEC** IO extension cable with Modbus RTU
- SEM** IO extension module with relay and Modbus RTU (input and output connections)
- SET** IO extension module for control of external accessories

Internal connections

R5-H

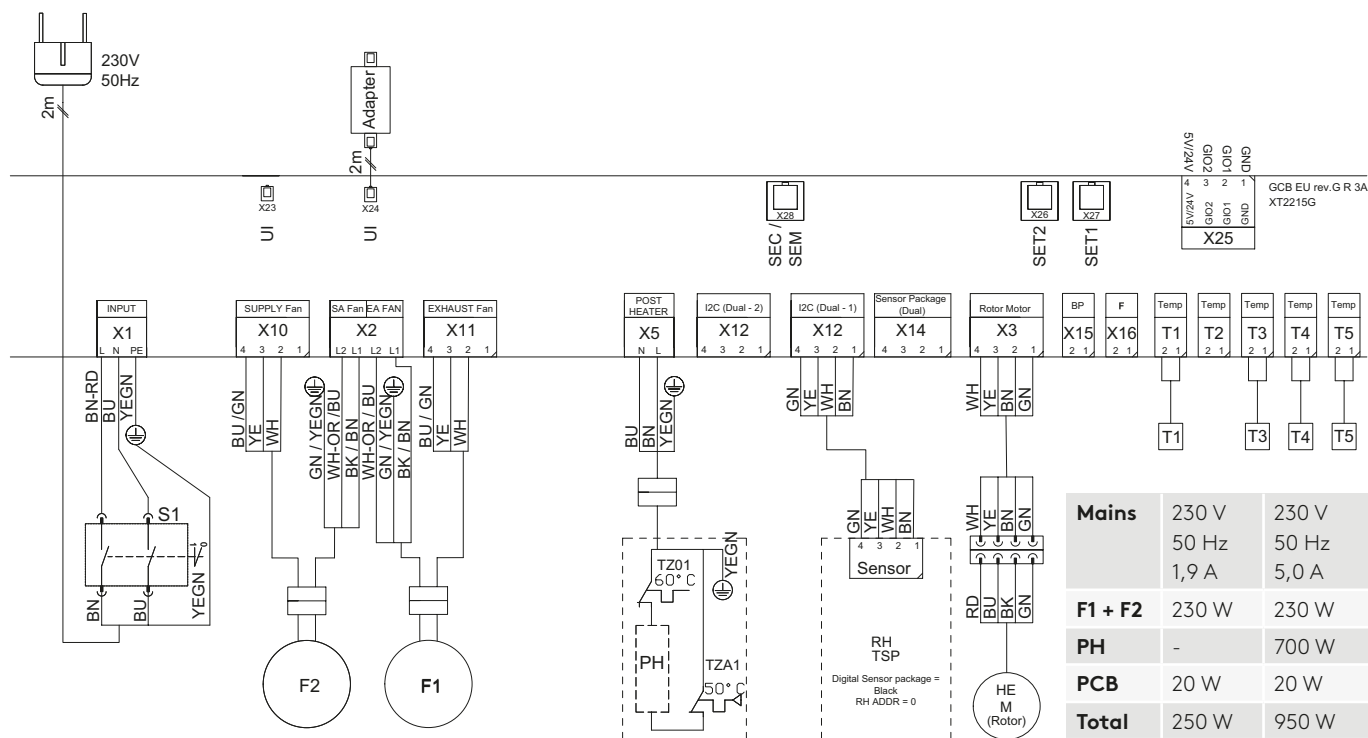

Device	Description
T1	L: Temperature sensor, outdoor air R: Temperature sensor, extract air
T3 TSP	L: Temperature sensor, extract air R: Temperature sensor, outdoor air
T4	L: Temperature sensor, supply air R: Temperature sensor, exhaust air
T5	L: Temperature sensor, exhaust air R: Temperature sensor, supply air
PH	Air heater, post heating
TZ01	Manual overhear protection
TZA1	Automatic overhear protection
F1	L: Extract fan R: Supply fan
F2	L: Supply fan R: Extract fan
M	Rotor's motor
S1	Use Switch
RH	Humidity sensor
UI	Connectors for control panel/cooker hood
SEC/SEM	Connector for connecting the SEC or SEM module
SET 1&2	Connectors for connecting the SET module
5V/24V	24V voltage output (IO max 125 mA/3W)
IO 1&2	Two general-purpose IO connectors

Installation options

Ventilation unit installation site

The ambient temperature where the ventilation unit will be installed must be between +10 - (+50) °C.

Note! Unit has no condensation drain. Therefore it's not suitable in houses where unit's extract air humidity may be high. (i.e. sauna, spa, etc.)

Mounting on the floor

The unit should be installed on the floor. The device is heavy. Make sure that the mounting base will withstand its weight.

The rear edge of the unit must be at least 50 mm off the wall.

Free space in front of the maintenance door of the unit must be at least 1200 mm and above the electrical box at least 250 mm.

Changing flow direction

The ventilation unit has been supplied in the left-hand version (L) and it can be changed to right-hand version (R) on site.

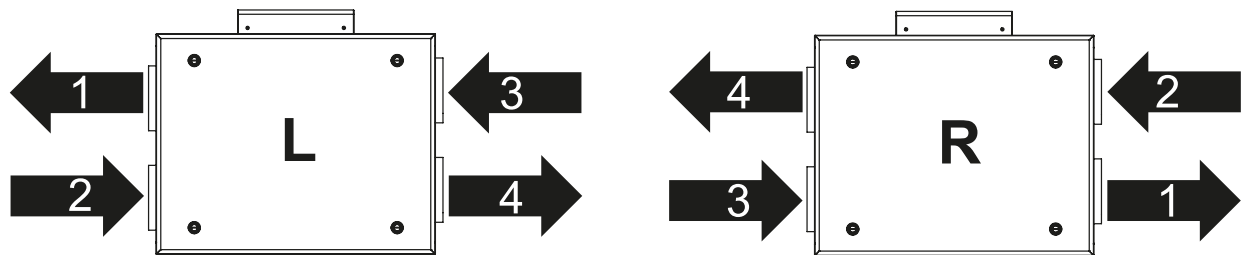

- 1. Supply air
- 2. Extract air
- 3. Outdoor air
- 4. Exhaust air



Mounting on a base

The CASA R5-H ventilation unit can also be mounted on the floor using a base (R05HFMB) which is available as an accessory.

The ventilation unit's base is mounted horizontally by using the adjuster feet. Einstellbereich 35 mm (15-50 mm).

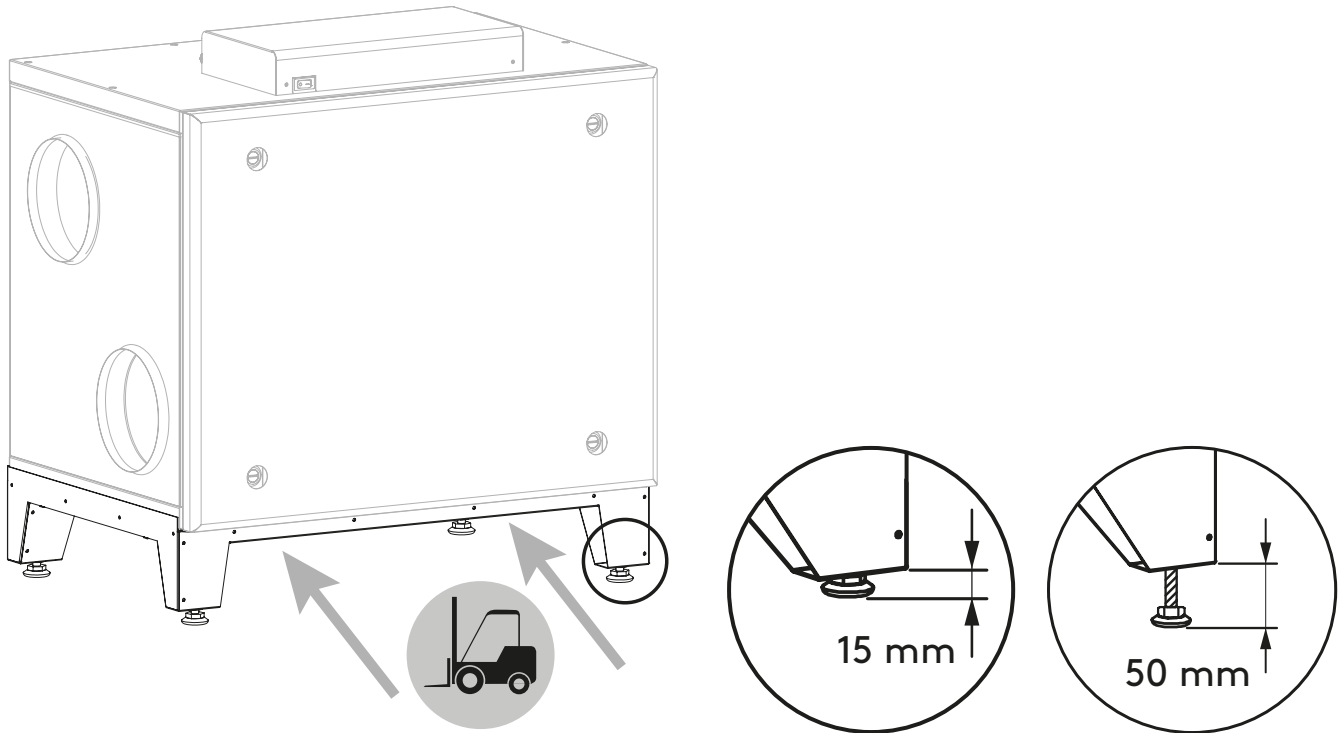



Product codes

R5-H

Product	Product code	LVI no.	GTIN
CASA R5-H Genius L/R RHCO2	R05HL00G00C	7907332	6430080090204
CASA R5-H Genius L/R 700W RHCO2	R05HL07G00C	7907333	6430080090211

Accessories

Product	Part no.	LVI no.	GTIN
Set of filters ISO ePM1 50% (F7)	R05HFS	7907195	6415879071954
Base	R05HFMB	7907495	6430080091843

CASA - Accessories

Control accessories	Part no.	LVI no.	GTIN
GC10 CASA Genius control panel and WiFi	GC10	7907376	6430080090846
GC10 CASA Genius control panel (black) and WiFi	GC10BL	7907505	6430080092024
GC10 control panel + 10 m long cable	GC14	7907377	6430080090853
GC10 control panel (black) + 10 m long cable	GC14BL	7907509	6430080092031
GC10 control panel + 10 m long cable + frame	GC15	7907378	6430080090860
GC10 control panel + frame	GC16	7907379	6430080090877
Frame for control panel GC10	102SAK	7906675	6415879066752
Dock station for GC10 Control Panel	CCDW	7907496	6430080091935
CASA Genius boost/home/away control button	GC04	7907057	6430080090013
CASA Genius boost control button	GC03	7907399	6430080091119

Building automation	Part no.	LVI no.	GTIN
Modbus connection module with electrical box	SEMIO	SEMIO	6430080091348
Modbus connection module for DIN rail	SEM	SEM	6415879067346
Connection cable (configurable I/O) for Genius ventilation units	SEC	SEC	6415879067353
Room temperature sensor (temperature data to Modbus)	WSTC	WSTC	6415879069395

Automatic functions	Part no.	LVI no.	GTIN
RH + CO ₂ + VOC automation	GRHCV	7907476	6430080091461

Waterborne air coolers	Part no.	LVI no.	GTIN
Cooling coil package Ø 160	SDCW160	7906805	6415879068053

Waterborne air heaters	Part no.	LVI no.	GTIN
Heating coil package Ø 160	SDHW160	7906804	6415879068046

Brine air heater/cooler for ground source heat pump	Part no.	LVI no.	GTIN
Heating/cooling coil Ø 250, G4	SDHW250F	7906808	6415879068084

Electric air heater	Tuotekoodi	LVI nro	GTIN
Electric heater Ø 160, 1,2 kW	SDHE160-1T	7906724	6415879067247
Prefilter box Ø 160 mm, G4	FLK16	7906748	6415879067483

Duct mounted shut-off dampers	Part no.	LVI no.	GTIN
Damper Ø 160 mm	SDD160	7906993	6415879069937

Other accessories	Part no.	LVI no.	GTIN
Connection module for Genius ventilation unit	SET	7906733	6415879067339
SET / power source for actuators	POWER24V20W	7906840	6415879068404
PTH Regulation for constant duct pressure	PTH	7906728	6415879067285

Feel good **inside**



Swegon 