

REACT Pacific

Chilled beam with integrated variable flow regulation



QUICK FACTS

- **Sustainable by Design** - Crafted from recycled steel, supporting low carbon impact and circularity.
- **Stable performance** — Pressure-independent control ensures consistent airflow and comfort.
- **Modular design** — Three-module system for adaptable, optimized indoor climate solutions.
- **Flexible control architecture** — Supports 0–10 V, Modbus RTU or BACnet integration for seamless connection to BMS and room control systems.
- **Integrated SA/EA air modules** — Optional supply and extract modules for a seamless look.
- **Coanda wing option** — Optimized air distribution for open ceilings, eliminating drafts.

Primary airflow l/s	Pressure range Pa	Cooling capacity W	Heating capacity Water W
Up to 97	30 to 150	Up to 2158	Up to 2494

Additional SA/EA module		
SA: Supply airflow l/s	SA: Cooling capacity W	EA: Extract airflow l/s
Up to 65	Up to 470	max. 100

Size					
Length (mm)	Width (mm)		Height (mm)		
	min./max.		Ø125	Ø160	Ø200
1200, 1800, 2400, 3000*	594 / 667*		189	244	299

* The REACT Pacific is obtainable in lengths and widths that fit the majority of false ceilings available on the market.

Cooling, air: $\Delta T_i = 6K$ / water: $\Delta T_{mk} = 8,5K$, $t_{water} = 14/17,3^\circ C$, waterflow 0,1l/s
 Heating, air: $\Delta T_i = -1K$ / water: $\Delta T_{mk} = 16K$, $t_{water} = 45/31^\circ C$, waterflow 0,045l/s
 Commissioning pressure: 70 Pa
 30dB with 5db room attenuation

Contents

Technical description	3
REACT system.....	3
Communicates via wired control	3
REACT supports different combinations of indoor climate systems	3
Chilled beam REACT Pacific	3
Design	4
Functionality	5
Material and surface treatment	5
Certifications/Standards	5
Adaptation	6
Hygieneic solution.....	7
Technical data.....	8
Dimensions	8
Weight	9
Cooling.....	10
Designations	10
Heating.....	12
Comfort and commissioning functions.....	14
Anti Draught control (ADC).....	14
K-factor settings	14
Installation, commissioning and maintenance	15
Connection dimensions.....	15
Electrical data	15
Flush-mounted installation	15
Accessories and optional extras	16
Factory-fitted accessories/optional extras.....	16
Loose accessories.....	17
Ordering key	19
Product.....	19
Possible combinations for false ceilings below	19
Accessories	20
Specification text.....	21

Technical description

REACT system

Variable air volume solutions with the REACT system is straightforward and reliable.

REACT is designed for projects where a wired control strategy and integration with the building management system (BMS) are preferred.

Communicates via wired control

REACT room units and controllers communicate wired via 0–10 V, Modbus RTU or BACnet MS/TP.

This ensures robust and stable communication, fully aligned with standard BMS architectures.

REACT supports different combinations of indoor climate systems

REACT enables flexible system design by supporting both waterborne and airborne climate solutions.

It allows integration from system level down to zone and room level, making it possible to combine multiple solutions within the same building.

This flexibility ensures that each space can be optimized based on its specific requirements.

Chilled beam REACT Pacific

REACT Pacific is designed for integration with traditional wired control systems, enabling demand-controlled operation and precise room regulation.

With pressure-independent airflow control and flexible BMS connectivity, REACT Pacific ensures stable performance and reliable operation.

The result is a robust and future-proof solution that delivers high indoor comfort, energy efficiency, and full control within the building management system.



Figure 1. REACT Pacific



Figure 2. REACT Pacific from the opposite side.

Design

VAV - 2-way blowing chilled beam REACT Pacific

REACT Pacific is a new generation of 2-way blowing chilled beams designed for buildings that require stable air-flow, excellent comfort and a clean, architectural appearance. The beam delivers cooling, heating and ventilation with high induction and low sound levels — perfect for offices, schools and hotels.

REACT Pacific is designed for seamless ceiling integration, offering flexible linear installation in both continuous series and individual units to accommodate a wide range of architectural designs. This design allows for creative and functional solutions that can adapt to various interior layouts and design preferences.

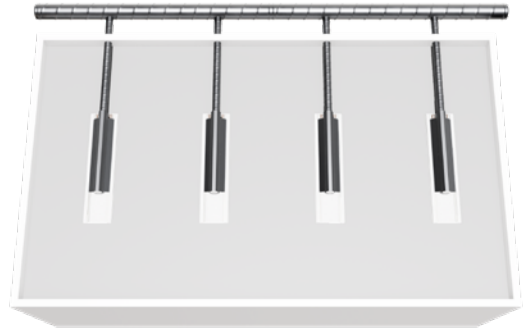

Figure 3. Example with four REACT Pacific installed in a room.

Modular by design

The REACT Pacific platform is built from interchangeable modules:

- **Air Duct Module** - Available in three duct sizes and several lengths with integrated damper for easy balancing.
- **Capacity Module** - High-performance cooling and heating coil, available in several lengths to match different room sizes and loads.
- **Design Module** - Modern, clean surfaces with hidden water and air connections — allowing the beam to blend seamlessly into any interior.

This modularity simplifies design, installation, and future adaptations.



Figure 4. Example with REACT Pacific installed in serie.

Lightweight & service-friendly

Construction reduces weight and improves access to all internal components, ideal for buildings with tight installation spaces and renovation projects.

Quiet and efficient

- High induction ensures excellent air quality and thermal comfort
- Low pressure drop reduces fan energy
- Quiet operation suitable for noise-sensitive environments.

Sustainable by default

- Optimised material use
- Constructed from reused and renewably produced steel
- Long service life and easy refurbishment

Functionality

Variable air volume (VAV)

REACT Pacific features integrated actuator to adjust the airflow. Easy to integrate into any external building management system.

This ensure:

- Optimal comfort in every room or zone
- Lower energy use
- Flexible integration with BMS and room control systems

Flow Control

An integrated damper and actuator continuously adjust the airflow, ensuring accurate air volumes, stable performance, and consistent comfort.

Anti Draught Control (ADC)

Anti Draught Control (ADC) ensures that airflows can be redirected to reduce the risk of draughts in the occupied zone.

Modularity

As buildings become more energy-efficient, cooling and heating demands decrease while fresh air needs remain occupant-driven. REACT Pacific meets these requirements with a fully modular design:

- The capacity module is tailored to the required thermal load.
- The Airduct module is sized for the number of occupants.
- The design module can include a service hatch or supply/extract air modules.

This flexibility improves comfort, simplifies project design and supports long-term sustainability.

Material and surface treatment

Material

The air module is manufactured in RRP recycled and renewably produced galvanized sheet steel (zinc plated)

The capacity module (coil) is in copper and aluminium.

The design module (face plate) is in RRP recycled and renewably produced galvanized sheet steel (zinc plated) and painted in desired colour.

Standard colour:

- RAL 9003 White (Signal white), gloss ratio 30 ± 6%

Alternative standard colours:

- RAL 7037 Grey (Dusty gray), gloss ratio 30-40%
- RAL 9010 White (Pure white), gloss ratio 30-40%
- RAL 9005 Black (Jet black), gloss ratio 30-40%
- RAL 9006 Silver (White aluminium), gloss ratio 70-80%
- RAL 9007 Grey (Grey aluminium), gloss ratio 70-80%

Other colours available on request



Figure 5.



Figure 6. REACT Pacific full size.

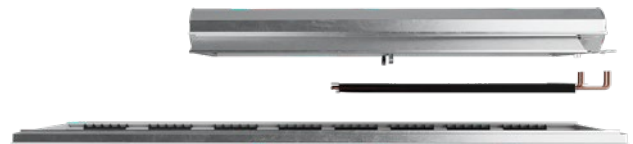

Figure 7. REACT Pacific with Air duct module, Capacity module and Design module in three different sizes.

Certifications/Standards

- EPD Declaration
- CE Declaration
- Eurovent

Adaptation

Installation in open plenum ceilings

Renovated buildings where open plenum ceilings are desired, REACT Pacific allows architects and designers to realize their vision without compromise.

With REACT Pacific's Coanda frame, air distribution is optimized, ensuring comfort and preventing drafts in the occupied zone, (see figure 8).



Figure 8. REACT Pacific with coanda frame for installation in open plenum. PACIFIC T-CF

Plasterboard frame

The plasterboard frame is designed to create a seamless and integrated transition between the REACT Pacific unit and the surrounding plasterboard ceiling, (see figure 9).

It allows for fine adjustments within the ceiling cut-out, ensuring precise alignment during installation and a clean final appearance. This compensates for tolerances in ceiling construction and simplifies on-site mounting.



Figure 9. REACT Pacific with Plasterboard frame, PACIFIC T-FPB

SA/EA module

An additional supply air (SA) and integrated extract air (EA) module can be added using an extended design frame, creating a seamless and unified appearance in the ceiling.

The SA/EA module is engineered to ensure optimal airflow separation, preventing short-circuiting between supply and extract air. This maintains efficient ventilation performance, supports good room air quality and preserves the intended air distribution pattern, (see figure 10).



Figure 10. PACIFIC SA/EA module (Supply/Extract air module)

Longer design module

In certain cases it could be advantageous to select a design module that is extra long in relation to the capacity module. One typical case is when the beam is installed in a plasterboard ceiling and there is a need for inspecting the valves and/or the commissioning damper.

By employing a design module that is longer than the air module and the capacity module, you get a built-in inspection cover per automatic control system, (see figure 11).

The inactive section of the design module is covered to avoid acoustic disturbance and so that the space above the false ceiling will not be visible from the room.



Figure 11. Built-in inspection cover through shorter capacity module or longer design module.

The face plate

The face plate of the design module is hinged and can be swung out from either side to a 90-degree open position. This completely exposes the coil for cleaning. Safety cords secure the face plate and ensure that it cannot fall down, (see figure 10).

Hygieneic solution

REACT Pacific can be ordered with a drop-down heat exchanger, allowing easy access for cleaning above the coil and inside the unit. The drop-down function is designed for single-person operation, enabling each side to be lowered individually for safe, simple, and efficient maintenance.

This makes REACT Pacific particularly suitable for environments with high hygiene requirements, such as hospitals and clean rooms, where accessibility and thorough cleaning are essential.



Figure 12. REACT Pacific with a drop-down heat exchanger.

Technical data

Dimensions

The product is available in different sizes

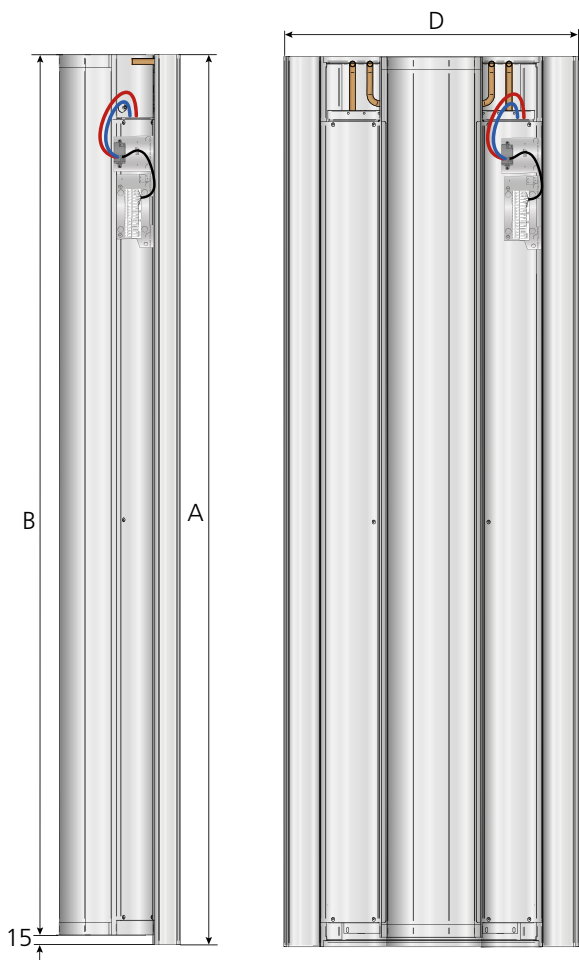

Figure 13. Dimension sketch - full size

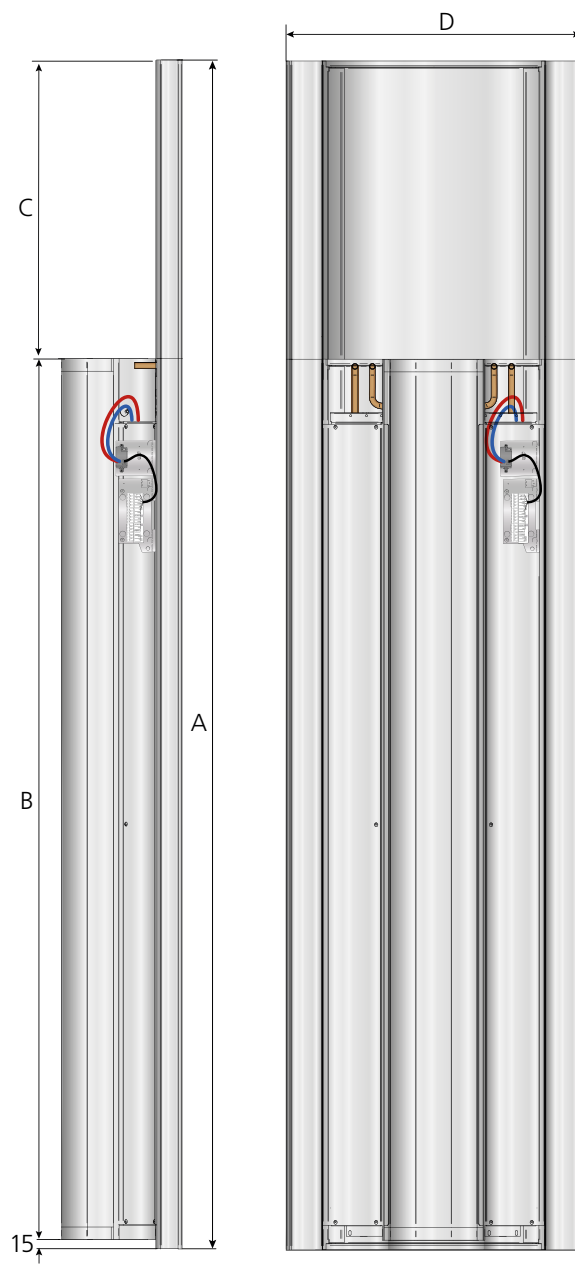

Figure 14. Dimension sketch - Modules in different sizes

For design module in T-bar with 600 mm centre-to-centre

A	B	C	D
1194; 1794	1170	(1194)=24; (1794)=624	594
1794; 2394	1770	(1794)=24; (2394)=624	594
2394; 2994	2370	(2394)=24; (2994)=624	594
2994	2970	(2994)=24	594

For design module in T-bar with 625 mm centre-to-centre

A	B	C	D
1242; 1867	1170	(1242)=72; (1867)=697	617
1867; 2492	1770	(1867)=97; (2492)=722	617
2492	2370	(2492)=122	617

For design module in T-bar with 675 mm centre-to-centre

A	B	C	D
1342; 2017	1170	(1342)=172; (2017)=847	667
2017; 2692	1770	(2017)=247; (2692)=922	667
2692	2370	(2692)=322	667

For design module in Clip-in ceiling and sheet metal ceiling coffers

A	B	C	D
1198; 1498; 1698; 1715; 1798	1170	(1198)=28; (1498)=328; (1698)=528; (1715)=545; (1798)=628	598
1798; 2398	1770	(1798)=28; (2398)=628	598
2398; 2998	2370	(2398)=28; (2998)=628	598
2998	2970	(2998)=28	598

Weight

Since the product can be combined in numerous combinations, we show the weight for the three different modules, where you pick your size and add them together to have the total weight of your product.

Air module

Length (mm)	Air connection ø	Weight (kg)
1170	125	6,38
1170	160	6,94
1170	200	7,66
1770	125	9,63
1770	160	10,36
1770	200	11,46
2370	125	12,74
2370	160	13,75
2370	200	15,11
2970	125	15,8
2970	160	17,03
2970	200	18,71

Capacity module

Length (mm)	Water volume (l)		Dry weight (kg)
	Cooling circuit	Heating circuit	
1000	0,97	0,26	3,41
1000 NPT	0,97	0,26	3,79
1600	1,52	0,40	5,02
1600 NPT	1,52	0,40	5,4
2200	2,09	0,53	7,06
2200 NPT	2,09	0,53	7,44
2800	2,63	0,67	8,63
2800 NPT	2,63	0,67	9,01

Design module

Length (mm)	Width (mm)	Weight (kg)
1194	594	5,35
1794	594	7,65
2394	594	9,96
2994	594	12,27
1198	598	5,39
1798	598	7,72
2398	598	10,04
2998	598	12,36
1213	603	5,49
1823	603	7,87
2433	603	10,25
3043	603	12,63
1242	617	5,72
1867	617	8,21
2492	617	10,71
1342	667	6,55
2017	667	9,46
2692	667	12,38

Cooling

The capacities are measured in conformity with EN 15116.

Sizing guide, Table 2.

The values in table 2 refer to the combination of the product's largest possible Air module with its largest possible capacity module, for the listed product length.

Example: Product length: 1800 mm

Air module: 1770 mm

Capacity module: 1600 mm

N.B.! The total cooling capacity is the sum of the airborne and waterborne cooling capacities.

Designations

P: Capacity (W, kW)

t_r : Room temperature (°C)

t_m : Mean water temperature (°C)

v: Velocity (m/s)

q: Airflow (l/s)

p: Pressure, (Pa, kPa)

ΔT_m : Temperature differential [$t_r - t_m$] (K)

ΔT : Temperature differential, between inlet – return (K)

Supplementary index: k = cooling, v = heating, l = air, i = commissioning

Diagrams 1a-1b.

The correction factor in Diagram 1 shows how the cooling capacity is affected by the water flow, assuming that the temperature difference between the room and the mean cooling water temperature is kept constant. A correction factor of 0.7 corresponds to a 30% reduction in cooling capacity, compared to correction factor 1.0.

The diagram is valid for the 1000-capacity module; however, the curve is very similar for the 1600-capacity module as well. The diagram is intended to provide a general indication of how the water flow affects the cooling capacity. If specific cooling capacity values are required for a water flow other than the one specified in the cooling capacity table, the calculation software Single Product Calculator must be used.

The cooling capacity of the primary air for chilled beam and additional SA module

The following formula can be used for calculating the cooling capacity of the primary air for the chilled beam and the additional SA module:

$$P_1 = q_1 \times 1.2 \times \Delta T_1$$

P_1 = cooling capacity of the primary air (W)

q_1 = the primary airflow (l/s)

ΔT_1 = Temperature differential between the temperature of the primary air and the room temperature (K)

Pressure drop for the cooling circuit

The following formula for calculating the pressure drop in the cooling circuit:

$$\Delta p_k = A \cdot q_k^B$$

A = constant, read from table 1 (Kpa)

B = constant, read from table 1

q_k = cooling water flow (l/s)

Table 1. Pressure drop, water in capacity module

Capacity module, Length (mm)	A	B
1000	708,1	1,69
1600	983,5	1,72
2200	580,7	1,80
2800	597,6	1,76

Diagram 1a. Water flow – capacity correction, cooling

Length of Capacity module: 1000 and 1600 mm

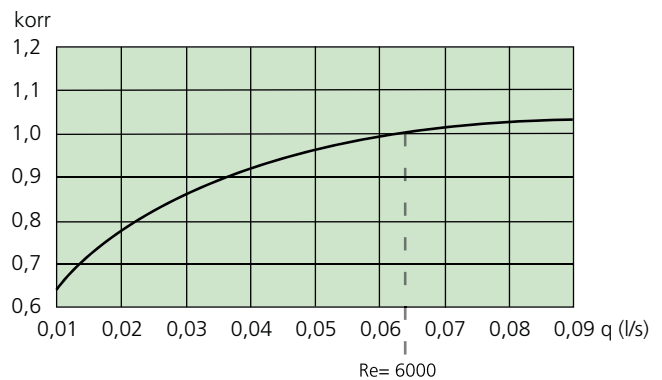

Diagram 1b. Water flow – capacity correction, cooling

Length of Capacity module: 2,200 and 2800 mm

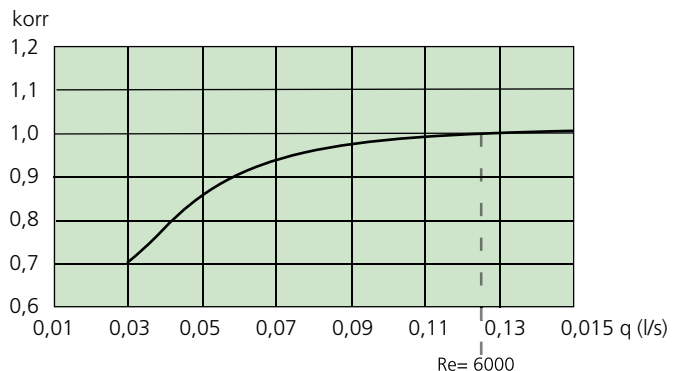

Table 2. Data – Cooling. Sizing guide for the REACT Pacific , 70 Pa nozzle pressure

Product length (mm)	Airflow		Sound level, dB(A) * Connection (mm)			Cooling capacity, primary air (W), ΔT_1			Cooling capacity of the water (W), ΔT_{mk}					k-factor
	(l/s)	(m ³ /h)	Ø125	Ø160	Ø200	6	8	10	6	7	8	9	10	
1200 **	12,5	45	<20	<20	<20	91	121	152	290	338	387	435	488	1,5
1200 **	23,4	84	<20	<20	<20	170	226	283	346	409	466	523	585	2,8
1200 **	36,0	130	24	21	22	261	348	435	381	448	509	576	638	4,3
1800 **	25,9	93	<20	<20	<20	188	251	313	480	563	645	735	811	3,1
1800 **	38,5	139	21	<20	21	279	372	465	528	617	706	795	884	4,6
1800 **	51,0	184	26	23	24	370	493	617	552	643	743	835	927	6,1
2400 ***	34,3	123	21	<20	<20	249	332	415	686	809	922	1035	1159	4,1
2400 ***	51,9	187	23	20	20	376	501	627	763	897	1021	1156	1280	6,2
2400 ***	71,1	256	28	25	24	516	687	859	810	939	1080	1210	1351	8,5
3000 ***	46,0	166	26	20	<20	334	445	556	866	1024	1182	1342	1502	5,5
3000 ***	71,1	256	35	27	24	516	687	859	982	1150	1318	1488	1657	8,5
3000 ***	87,8	316	39	33	27	637	849	1062	994	1164	1335	1505	1677	10,5

* The specified sound level is applicable to straight connection without duct bend and commissioning damper.

Room attenuation = 5 dB.

***) = The water capacity is specified for a water flow of 0.05 l/s and can vary depending on the installation and how the ADC air deflectors are set.

***) = The water capacity is specified for a water flow of 0.1 l/s and can vary depending on the installation and how the ADC air deflectors are set.

Detailed acoustic data can be obtained by sizing with Swegon's Single Product Calculator or Room Unit Design available at Swegon's home page: www.swegon.com.

Heating

Waterborne heating

The REACT Pacific is as standard equipped with a coil containing two separate tube circuits. The first functions as a cooling circuit and the second as a heating circuit. When hot water circulates in the tube circuit, the recirculated air from the room is heated up in the coil, is then mixed with the primary air and is distributed to the room. The inlet flow temperature of the heating water should be kept as low as possible to minimise the temperature differential between the air at ceiling level and at floor level. The temperature stratification in the room will be negligible if the inlet flow temperature is kept at 40°C or lower. If the inlet flow temperature is up to the recommended max temperature (60°C), the stratification will be perceptible even if it normally is within the prescribed range.

In the majority of cases, the system will heat the room air to a satisfactory temperature. In order to achieve good operating temperature, other factors must be taken into account. The following factors are typical in this respect: Window dimensions, the U factor of the windows, the orientation of the room, the location of the occupants, etc. The quality and dimensions of the windows are also important with regard to possible cold down draughts. The windows used now-a-days are usually so well insulated that cold down draughts do not arise. Cold down draughts are especially likely to occur in the renovation of old buildings if the planner decides to keep the existing windows.

Recommendations for waterborne heating	
Max. permissible inlet flow temperature:	60° C
Min. permissible heating water flow:	0.013 l/s
Min. permissible nozzle pressure:	50 Pa

Sizing guide, Table 4.

The values in table 4 refer to the combination of the product's largest possible Air module with its largest possible capacity module, for the listed product length.

Example: Product length: 1800 mm

Air module: 1770 mm

Capacity module: 1600 mm

N.B.! The total heating capacity is the sum of the airborne and waterborne heating capacities. If the primary air temperature is lower than the room temperature, it causes negative impact on the total heating capacity.

The heating capacity of the primary air for chilled beam and supply air module

The following formula can be used for calculating the heating capacity of the primary air for the chilled beam and the supply air module:

$$P_1 = q_1 \times 1.2 \times \Delta T_1$$

P_1 = heating capacity of the primary air (W)

q_1 = the primary airflow (l/s)

ΔT_1 = Temperature differential between the temperature of the primary air and the room temperature (K)

Diagram 2.

The correction factor in Diagram 2 shows how the heating capacity is affected by the water flow, assuming that the temperature difference between the room and the mean heating water temperature is kept constant. A correction factor of 0.7 corresponds to a 30% reduction in heating capacity, compared to correction factor 1.0.

The diagram is valid for the 2200-capacity module; however, the curve is very similar for the other capacity module sizes as well. The diagram is intended to provide a general indication of how the water flow affects the heating capacity. If specific heating capacity values are required for a water flow other than the one specified in the cooling capacity table (0.05 l/s), the calculation software Single Product Calculator must be used.

Pressure drop for the heating water circuit

Use the following formula for calculating the pressure drop in the heating circuit:

$$\Delta p_k = A \cdot q_k^B$$

A=constant, read from table 3, (Kpa)

B=constant, read from table 3

q_k =heating water flow (l/s)

Table 3. Pressure drop water in capacity module

Capacity module, Length (mm)	A	B
1000	115,8	1,39
1600	192,0	1,39
2200	106,9	0,99
2800	139,6	0,99

Diagram 2. Water flow – capacity correction, heating

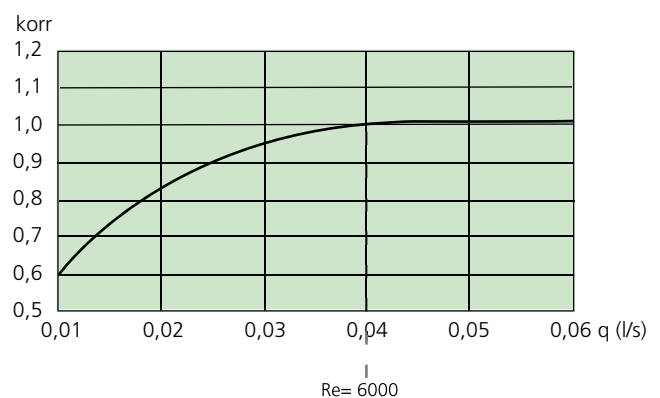

Table 4. Data – Heating. Sizing guide for the REACT Pacific, 70 Pa

Product Length (mm)	Airflow		Sound level, dB(A) *			Heating capacity, water (W) **					k-factor
	(l/s)	(m ³ /h)	Connection (mm)			ΔT_{mv}					
			Ø100	Ø125	Ø160	5	10	15	20	25	
1200	12,5	45	<20	<20	<20	246	334	424	521	630	1,5
1200	23,4	84	<20	<20	<20	279	376	478	589	714	2,8
1200	36,0	130	24	21	22	301	409	521	642	783	4,3
1800	25,9	93	<20	<20	<20	443	599	767	957	1179	3,1
1800	38,5	139	21	<20	21	469	637	815	1015	1254	4,6
1800	51,0	184	26	23	24	519	708	907	1129	1394	6,1
2400	34,3	123	21	<20	<20	594	804	1024	1271	1572	4,1
2400	51,9	187	23	20	20	643	873	1115	1382	1708	6,2
2400	71,1	256	28	25	24	673	915	1169	1454	1798	8,5
3000	46,0	166	26	20	<20	810	1103	1401	1711	2025	5,5
3000	71,1	256	35	27	24	868	1179	1501	1832	2173	8,5
3000	87,8	316	39	33	27	894	1219	1550	1890	2246	10,5

* The specified sound level is applicable to straight connection without duct bend and commissioning damper.

Room attenuation = 5 dB.

***) = The water capacity is specified for a water flow of 0.05 l/s and can vary depending on the installation and how the ADC air deflectors are set.

Detailed acoustic data can be obtained by sizing with Swegon's Single Product Calculator or Room Unit Design available at Swegon's home page: www.swegon.com.

Comfort and commissioning functions

Anti Draught control (ADC)

ADC consists of a number of sections with adjustable fins arranged in the outlet of the unit. With a simple grip of the hand, the fins can be set to an appropriate angle to direct the discharge of air and in this way create the desired air distribution pattern.

The standard setting for ADC is straight but the unit can be supplied factory-preset to a V-shape distribution pattern, if desired.

The ADC is also included as standard feature.

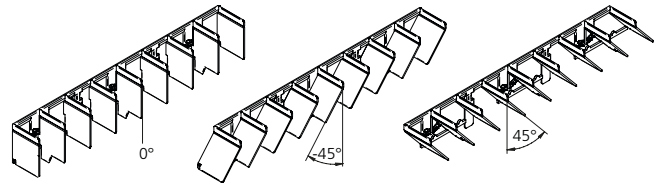

Figure 15. Detailed illustration of ADC

K-factor settings

REACT Pacific continuously regulates the airflow to each room or zone according to the setpoint from the higher-level system. The current k-factor position can be read directly on the product via the positioning lever on the k-factor label.

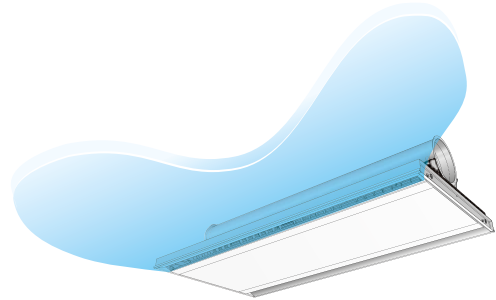

Figure 16. ADC set to the V-shape setting

Check measure

For detailed instructions, see REACT Pacific IOM manual on www.swegon.com.

Flow tolerance

Air module ∅	Minimum flow **			Tolerance Q* ±5 % but at least ±x		
	l/s	m ³ /h	cfm	l/s	m ³ /h	cfm
1200	7	25	14,8	2	7	4
1800	9	32	19	2	7	4
3400	11	39	23	2	7	4
3000	14	50	29	2	7	4

* Installed according to instructions

** For flows below the lowest specified level, we cannot guarantee the tolerances.

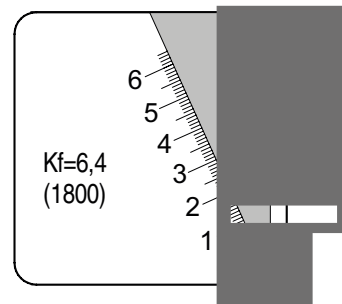

Figure 17. Positioning lever and k-factor label

Installation, commissioning and maintenance

Mounting

The REACT Pacific is supplied with four mounting brackets and self-tapping screws packaged separately and supplied with each unit. The pre-punched holes in each mounting bracket simplify the fastening work.

The mounting brackets are designed enabling them to be turned in any optional direction depending to suit type of suspension system selected. Turned inward, the mounting brackets offer simple installation by means of mounting strips. Turned outward, the mounting brackets work at their best for suspending the beams by means of size M8 threaded rods.

Mounting strips and threaded rods are not supplied with the unit. If assembly fittings are required, these can be ordered separately.

Connecting water

The water pipes are always placed on the product's short side. Connect the water pipes using push-on couplings or compression ring couplings when the product is ordered without valves. Note that compression ring couplings require support sleeves inside the pipes.

Do not use solder couplings to connect the water pipes. High temperatures can damage the unit's existing soldered joints.

Flexible connecting hoses for water are available for flat-end pipes and valves, and can be ordered separately.

Recommended limit values

Max. recommended operating pressure:	1600 kPa
Max. recommended test pressure:	2,400 kPa
Min. permissible nozzle pressure:	50 Pa
Min. cooling water flow*	0.03 l/s
Capacity module: L = 1,100; 1,600 mm:	
Min. cooling water flow*	0.045 l/s
Capacity module: L = 2200; 2,700 mm:	
Min. permissible heating water flow*:	0.013 l/s
Increase in temperature, cooling water:	2-5 K
Decrease in temperature, heating water:	5-10 K
Min. permissible inlet flow temperature:	Should always be sized avoid condensation
Max. permissible inlet flow temperature:	60° C

* The min. recommended water flows ensure evacuation of any air pockets in the circuit.

Connection dimensions

Cooling (water):	Cu Ø 12 x 1.0 mm plain pipe end
Heating (water):	Cu Ø 12 x 1.0 mm plain pipe end
Air:	Ø125, 160 or 200 mm insertion joint
SA/EA module:	Spigot Ø160 mm

For detailed information about Installation, commissioning and maintenance, see REACT Pacific IOM-manual and Operations & maintenance

Electrical data

Power supply:	24V AC +-15% 50-60Hz	
	24V DC +-25%	
Power consumption	VA unit	W / unit
Inrush current 10 ms / 20 ms	72	36
Operation	4,5	3

Flush-mounted installation

The REACT Pacific is designed for installation flush-mounted in the majority of false ceilings available on the market.

- T-bar with 600 mm c-c and plasterboard ceilings:
Width: 594 mm
Lengths: 1,194; 1,794; 2,394 and 2,994 mm
- T-bar with 600 mm c-c in combination with 100 mm wide strip grid systems, 1800 mm c-c
Width: 594 mm
Length: 1,715 mm
- T-bar with 625 mm c-c
Width: 617 mm
Lengths: 1242; 1867; 2,492 mm
- T-bar with 675 mm c-c
Width: 667 mm
Lengths: 1,342; 2,017; 2,692 mm
- T-bar with IP units (USA)
Width: 23.7 inches (603 mm)
Length: 47.8, 71.8, 95.8, 119.8 inches (1213; 1823; 2433; 3043 mm)
- Clip-in ceiling / sheet metal ceiling coffers 598 mm
Lengths: 1,198; 1,498; 1,698; 1,715; 1,798; 2,398; 2,998 mm

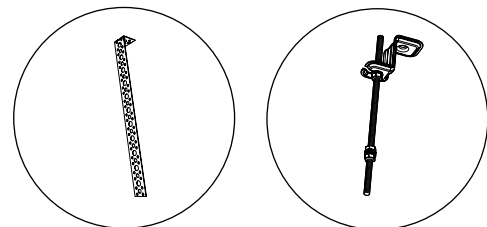

Figure 18. Suspension variant with mounting brackets and threaded rods respectively.

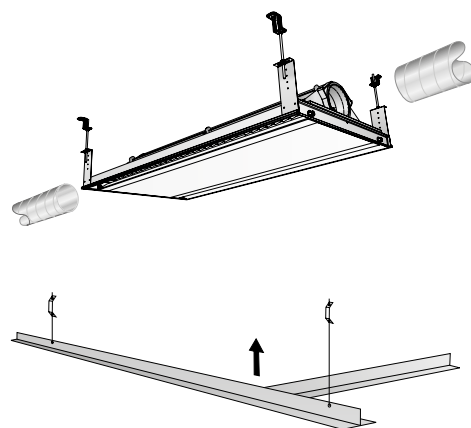

Figure 19. Installation of REACT Pacific, here suspended by means of threaded rods.

Accessories and optional extras

Factory-fitted accessories/optional extras

Additional SA/EA module

Supply and extract air module SA/EA

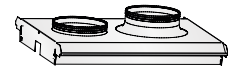

Extract air register

EXC Extract air register

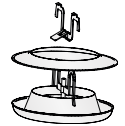

Valve, cooling & heating

Factory fitted valves for cooling and heating. The valve is mounted on the product and preset fully open.

Unit	Function	Type	Dim.	K _v (m ³ /h)
1200, 1800	Cooling/heating	VEN115	DN15 (½")	0.10-0.89
2400, 3000	Cooling	VEN120	DN20 (¾")	0.31-1.41
2400, 3000	Heating	VEN115	DN15 (½")	0.10-0.89

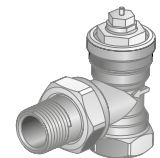

For more information about the valve, see the separate product data sheet on www.swegon.com.

Actuator, cooling & heating, ACTUATORc 24 V NC

Factory fitted valve actuators for cooling and heating.

24V AC/DC, NC (Normally Closed).

For more information about the actuator, see the separate product data sheet on www.swegon.com.



Condensation sensor SYST PCS

The detector operates at the dew point temperature rather than a fixed relative humidity value. The dew-point is calculated from a temperature compensated RH element and an extremely accurate sensor element that is bound to the metal plate on the detector.

Compatible with LUNA.

For more information about the condensation sensor, see the separate product data sheet on www.swegon.com.

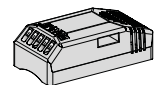

Hygieneic solution

REACT Pacific can be ordered with a drop-down heat exchanger, allowing easy access for cleaning above the coil and inside the unit. The drop-down function is designed for single-person operation, enabling each side to be lowered individually for safe, simple, and efficient maintenance.

This solution makes REACT Pacific particularly suitable for environments with high hygiene requirements, such as hospitals and clean rooms, where accessibility and thorough cleaning are essential.



Loose accessories

Additional SA/EA module

Supply and extract air module SA/EA

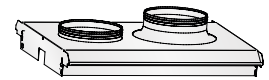

Extract air register

EXC Extract air register

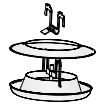

Plasterboard frame, REACT Pacific T-FPB

Available in four sizes: 1194, 1794, 2394, 2994 mm

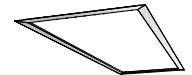

Coanda frame, REACT Pacific T-CF

Available in four sizes: 1194, 1794, 2394, 2994 mm

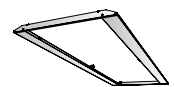

Transformer, Power ADAPT 20 VA (ARV)

Input voltage 230 V, 50-60 Hz

Output voltage 24 V AC

Power 20 VA

Enclosure IP33

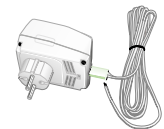

Transformer, SYST TS-1

Double-insulated protective transformer 230 V, AC/24 V AC

For more information, see the separate product data sheet on www.swegon.com.

Input voltage 230 V, 50-60 Hz

Output voltage 24 V AC,

Power 72 VA, Enclosure IP33

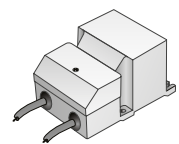

Condensation sensor SYST PCS

The detector operates at the dew point temperature rather than a fixed relative humidity value. The dew-point is calculated from a temperature compensated RH element and an extremely accurate sensor element that is bound to the metal plate on the detector.

Compatible with LUNA.



Valve, SYST VEN115 / SYST VEN120

Straight valves for cooling and heating.

VEN115 is preset fully open on Kv 0.89.

VEN120 is preset fully open on Kv 1.41

Unit	Function	Type	Dim.	K _v (m ³ /h)
1200, 1800	Cooling/heating	VEN115	DN15 (1/2")	0.10-0.89
2400, 3000	Cooling	VEN120	DN20 (3/4")	0.31-1.41
2400, 3000	Heating	VEN115	DN15 (1/2")	0.10-0.89

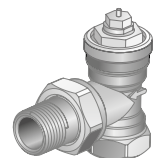

Note: VDN220 has to be installed outside the product.

For more information about the valve, see the separate product data sheet on www.swegon.com.

Valve actuator, cooling & heating, ACTUATORc 24 V NC

Valve actuators for cooling and heating.

24V AC/DC, NC (Normally Closed).

For more information about the actuator, see the separate product data sheet on www.swegon.com.



Card switch, SYST SENSO II

Key card holder for hotel rooms, for example.



Assembly fitting, SYST MS M8

For installation use the assembly fitting containing threaded rods, ceiling brackets and nuts to all four mounting brackets.

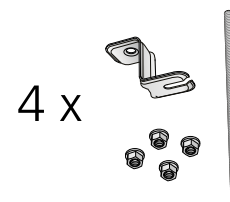

Flexible hoses, FH

Available in different lengths and with different couplings.

See separate product sheet "FH" on www.swegon.com.

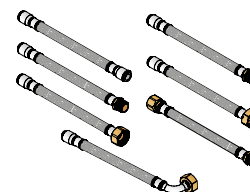

Venting nipple, SYST AR-12

A venting nipple is available as a complement to the flexible hoses with push-on couplings. The venting nipple fits directly in the push-on hose coupling and can be fitted in an instant.

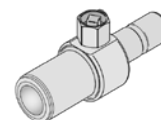

Ordering key

Product

Swegon's REACT Pacific chilled beam for integrated installation in false ceilings or open plenums, for cooling, heating and ventilation.

REACT Pacific	d-	aaaa-	b-	c-	dddd-	e
Version:						
Design module: Length (mm) 1194, 1198, 1213, 1242, 1342 1794, 1798, 1823, 1867, 2017 2394, 2398, 2433, 2492, 2692 2994, 2998, 3043						
Air module: Length (mm) 2=1170 3=1770 4=2370 5=2970						
Capacity module : Length (mm) 2=1000 3=1600 4=2200 5=2800						
Function: A=Cooling B=Cooling/Heating C=Ventilation HT-B=High-temperature cooling, heating and supply air						
Connection, air (mm): 1=125 2=160 3=200						

Example:

REACT Pacific-d-2394-4-4-A-1

Design module: 2394
Air module: 2370
Capacity module: 2200
Function: Cooling
Connection, air=125

The product is possible to order in multiple combinations between capacity modules, air modules and design modules. The rule is that the capacity module cannot be bigger than the air module, and the air module cannot be bigger than the design module. It is also possible to order a combination with SA/EA module, if the design module is at least 600 mm bigger than the air module.

See possible combinations for different false ceilings below.

Possible combinations for false ceilings below

For design module in T-bar with 600 mm centre-to-centre

Design module	Air module	Capacity module
1194; 1794	1170	1000
1794; 2394	1770	1000, 1600
2394; 2994	2370	1000, 1600, 2200
2994	2970	1000, 1600, 2200, 2800

For design module in T-bar with 625 mm centre-to-centre

Design module	Air module	Capacity module
1242; 1867	1170	1000
1867; 2492	1770	1000, 1600
2492	2370	1000, 1600, 2200

For design module in T-bar with 675 mm centre-to-centre

Design module	Air module	Capacity module
1342; 2017	1170	1000
2017; 2692	1770	1000, 1600
2692	2370	1000, 1600, 2200

For design module in Clip-in ceiling and sheet metal ceiling coffers

Design module	Air module	Capacity module
1198; 1498; 1698; 1715; 1798	1170	1000
1798; 2398	1770	1000, 1600
2398; 2998	2370	1000, 1600, 2200
2998	2970	1000, 1600, 2200, 2800

REACT Pacific

Choose from several factory mounded accessories in Single Product Calculator or Room Unit Design

Additional module PACIFIC T-SA/EA

Supply and extract air module SA/EA

Extract air register PACIFIC T-EA-EXC

EXC Extract air register

Fold-out coil PACIFIC HG

Accessories

Assembly piece	SYST MS	aaaa-	b	M8
Length, threaded rod (mm)	200; 500; 1000			
1 = One threaded rod				
2 = Two threaded rods and a thread lock				

Plasterboard ceiling frame	PACIFIC T - FPB	aaaa		
Length (mm)	1194, 1794, 2394, 2994			

Coanda frame	PACIFIC T - CF	aaaa		
Length (mm)	1194, 1794, 2394, 2994			

Flexible hoses	FH	aaaaaa	bbb	cccccc
<i>See separate product sheet "FH"</i>				
Coupling A				
Length (mm)				
Coupling B				

Specification text

Example of specification text according to VVS AMA

QLC.11 Active Chilled Beam

Manufacturer: Swegon

Type: REACT Pacific d "VAV"

Chilled beam for variable air volume with wired control and BMS integration:

- Air- and water-based chilled beam for comfort cooling and heating.
- Variable air volume (VAV) via external room control system or BMS.
- Induction-based operation for efficient heat and cooling transfer.
- Integrated water heat exchanger.
- Integrated air deflector for even air distribution and draught-free comfort.
- Modular design to suit room-specific requirements.
- Pressure-independent airflow control ensuring stable performance.
- Prepared for connection to control systems via 0–10 V, Modbus RTU or BACnet MS/TP.
- Control equipment (e.g. VAV controller, actuators) available factory-mounted or for external installation.
- Eurovent-certified (verified cooling capacity in accordance with EN 15116).
- Available in a wide range of colours and gloss levels.
- Suitable for most suspended ceiling systems.
- To be installed in suspended ceiling or as exposed installation according to drawings.
- Installation shall be carried out to allow access for service and cleaning.

Dimensions and connections:

- Lengths: 1200–3000 mm
- Nominal lengths: 600, 1200, 1800, 2400, 3000 mm
- Nominal width: 600 mm
- Height: 198 (ø125), 244 (ø160), 299 (ø200) mm
- Air connection: ø125, ø160, ø200 mm
- Water connection: Plain pipe end Cu Ø12 × 1.0 mm

Colour:

- RAL 9003 Signal White, gloss level 30 ±6%

Alternative:

- External control system / BMS-based control solution

Accessories:

- Extra air supply and extract air module, PACIFIC SA/EA module, xx pc.
- Extract air register, EXC, PACIFIC T-EA-EXC, xx pc.
- Plasterboard frame, PACIFIC T-FPB aaaa xx pc.
- Coanda frame, PACIFIC T-CF aaaa xx pc
- Fold-out coil, PACIFIC HG, xx pc
- Flexible connection hose, FH-aaaaa-bbb-cccc xx pc.
- Assembly piece SYST MS aaaa - b - M8 xx pc.
- Valve actuator, ACTUATORc 24V aa-bb, xx pc.
- Valve actuator, ACTUATORc 0-10V AC/DC aa, xx pc.
- Valve, SYST VEN-bbb, xx pc
- Condensation sensor PCS, xx pc.
- Transformer, SYST TS, xx pc
- Venting nipple SYST AR-12 xx pc.