

SERENITY 10

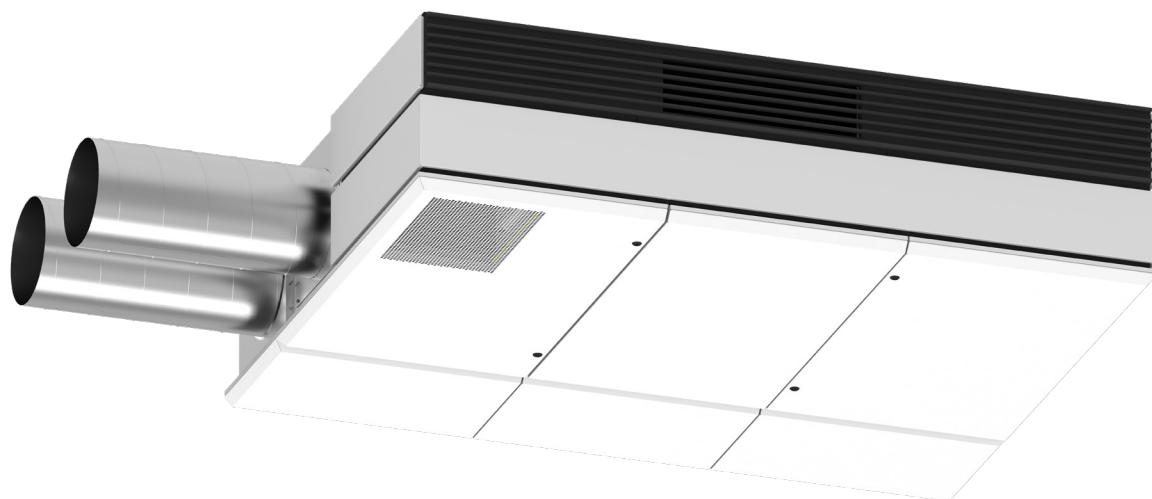

EN - INSTALLATION MANUAL FOR CONFIGURATIONS WITH A SIDE BOX

FR - MANUEL D'INSTALLATION POUR LES CONFIGURATIONS AVEC BOÎTIER LATÉRAL

NL - INSTALLATIEHANDLEIDING VOOR CONFIGURATIES MET EEN ZIJBEHUIZING

DE - INSTALLATIONSHANDBUCH FÜR KONFIGURATIONEN MIT SEITLICHEM GEHÄUSE

IT - MANUALE DI INSTALLAZIONE PER CONFIGURAZIONI CON BOX LATERALE

PL - INSTRUKCJA INSTALACJI DLA KONFIGURACJI Z BOCZNĄ OBUDOWĄ

EN - Contents

1. General informations	5
2. Installation on ceiling	6
3. Floor standing installation: horizontal	12
4. Floor standing installation: vertical	18

FR – Table des matières

1. Informations générales.....	5
2. Installation au plafond.....	6
3. Installation au sol : horizontale.....	12
4. Installation au sol : verticale.....	18

NL – Inhoudsopgave

1. Algemene informatie	5
2. Plafondmontage	6
3. Vloerinstallatie: horizontaal.....	12
4. Vloerinstallatie: verticaal.....	18

DE – Inhalt

1. Allgemeine Informationen	5
2. Deckenmontage.....	6
3. Bodenmontage: horizontal.....	12
4. Bodenmontage: vertikal.....	18

IT – Sommario

1. Informazioni generali	5
2. Installazione a soffitto	6
3. Installazione a pavimento: orizzontale	12
4. Installazione a pavimento: verticale.....	18

PL – Spis treści

1. Informacje ogólne.....	5
2. Montaż sufitowy.....	6
3. Montaż podłogowy: poziomy.....	12
4. Montaż podłogowy: pionowy	18

1.

EN - This is an extra manual if you configured your unit with the side box. Refer to the instructions below for the installation steps specific to this configuration. For all other aspects (wiring, available options, operation, etc.), please refer to the main manual.









FR - Ce manuel complémentaire s'applique uniquement si votre unité est configurée avec le boîtier latéral. Veuillez vous référer aux instructions ci-dessous pour les étapes d'installation spécifiques à cette configuration. Pour tous les autres aspects (câblage, options disponibles, fonctionnement, etc.), veuillez consulter le manuel principal.

NL - Dit aanvullende document is uitsluitend van toepassing als uw unit is uitgerust met de zijbehuizing. Raadpleeg de onderstaande instructies voor de installatiestappen die specifiek zijn voor deze configuratie. Voor alle overige aspecten (bekabeling, beschikbare opties, werking, enz.) verwijzen wij u naar de hoofdhandleiding.

DE - Dieses Zusatzdokument gilt nur, wenn Ihre Einheit mit dem seitlichen Gehäuse konfiguriert ist. Beachten Sie die nachstehenden Anweisungen für die installationspezifischen Schritte dieser Konfiguration. Für alle weiteren Aspekte (Verdrahtung, verfügbare Optionen, Betrieb usw.) beachten Sie bitte das Haupt-handbuch.

IT - Questo documento supplementare si applica solo se l'unità è configurata con il box laterale. Fare riferimento alle istruzioni riportate di seguito per le fasi di installazione specifiche di questa configurazione. Per tutti gli altri aspetti (cablaggio, opzioni disponibili, funzionamento, ecc.), consultare il manuale principale.

PL - Niniejszy dokument uzupełniający ma zastosowanie wyłącznie w przypadku, gdy urządzenie jest skonfigurowane z boczną obudową. Zapoznać się z poniższymi instrukcjami dotyczącymi etapów instalacji specyficznych dla tej konfiguracji. W pozostałych kwestiach (okablowanie, dostępne opcje, obsługa itp.) należy odwołać się do instrukcji głównej.

 <p>T30</p>	 <p>M6x20</p>
 <p>T25</p>	 <p>M5</p>
 <p>Hex 10mm</p>	 <p>6x15mm</p>
 <p>13mm</p>	 <p>M8</p>

2.



EN - The four mounting points are positioned asymmetrically relative to the center of the unit.
Threaded rods ● to be used = M8

FR - Les quatre points de montage sont positionnés de manière asymétrique par rapport au centre de l'unité.
Tiges filetées ● à utiliser = M8

NL - De vier bevestigingspunten zijn asymmetrisch ten opzichte van het midden van de unit geplaatst.
Te gebruiken ● draadstangen = M8

DE - Die vier Befestigungspunkte sind asymmetrisch zur Mitte des Geräts positioniert.
Zu verwendende ● Gewindestangen = M8

IT - I quattro punti di montaggio sono posizionati in modo asimmetrico rispetto al centro dell'unità.
Barre filettate ● da utilizzare = M8

PL - Cztery punkty mocowania są ustawione asymetrycznie względem środka urządzenia.
Gwintowane ● pręty do użycia = M8

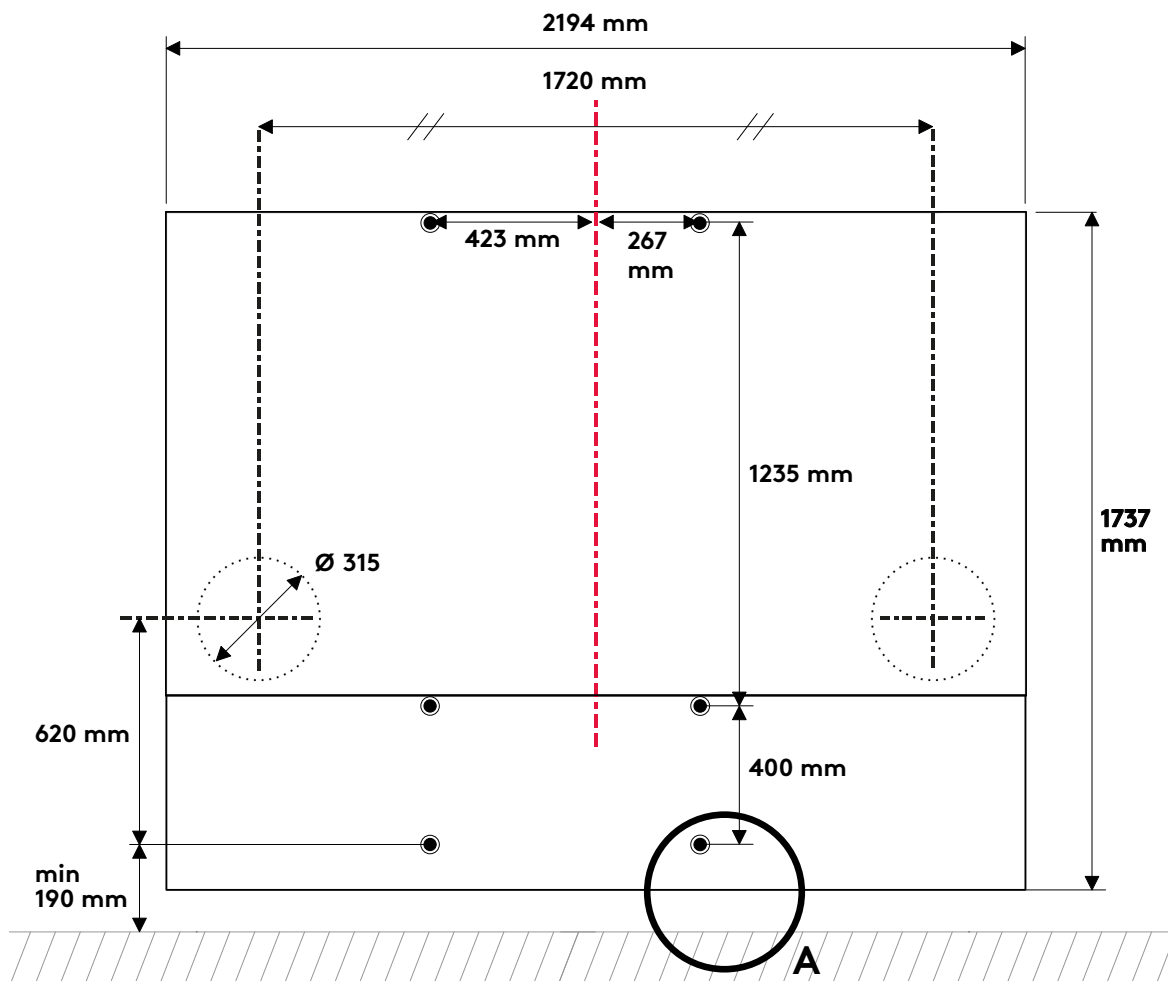
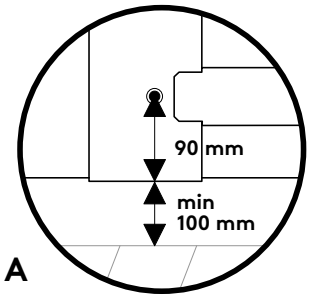
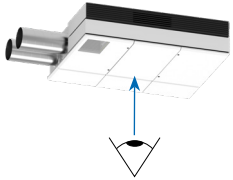

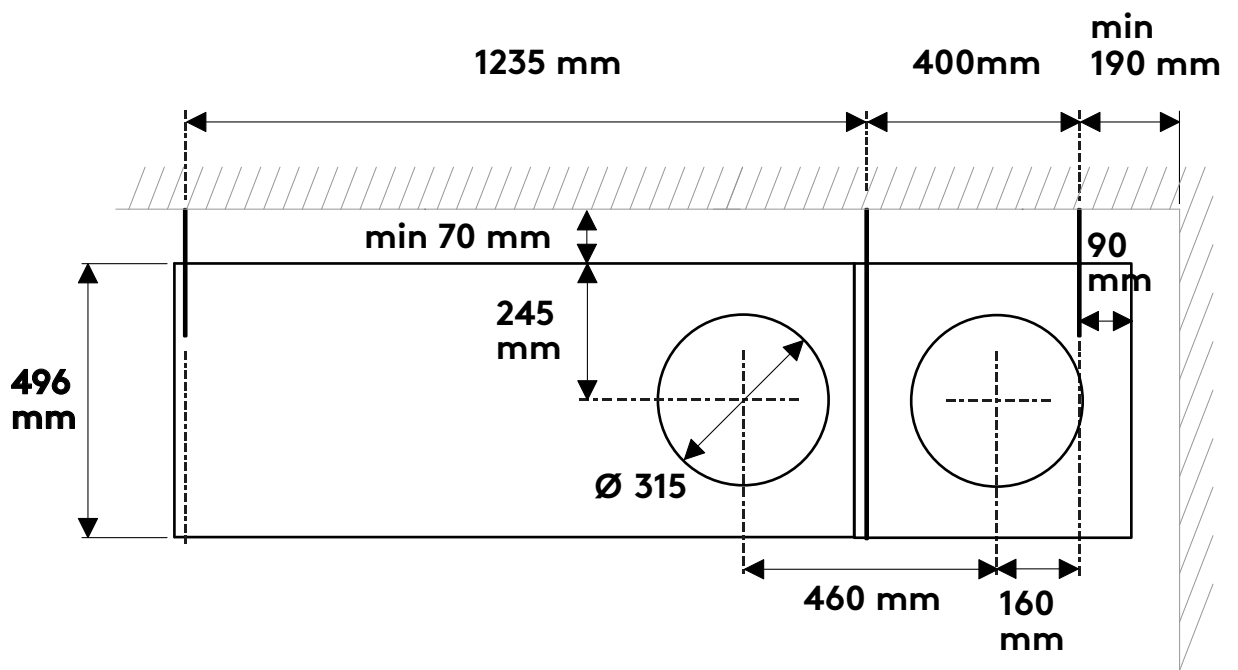
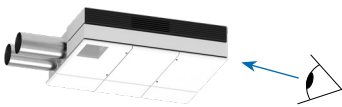
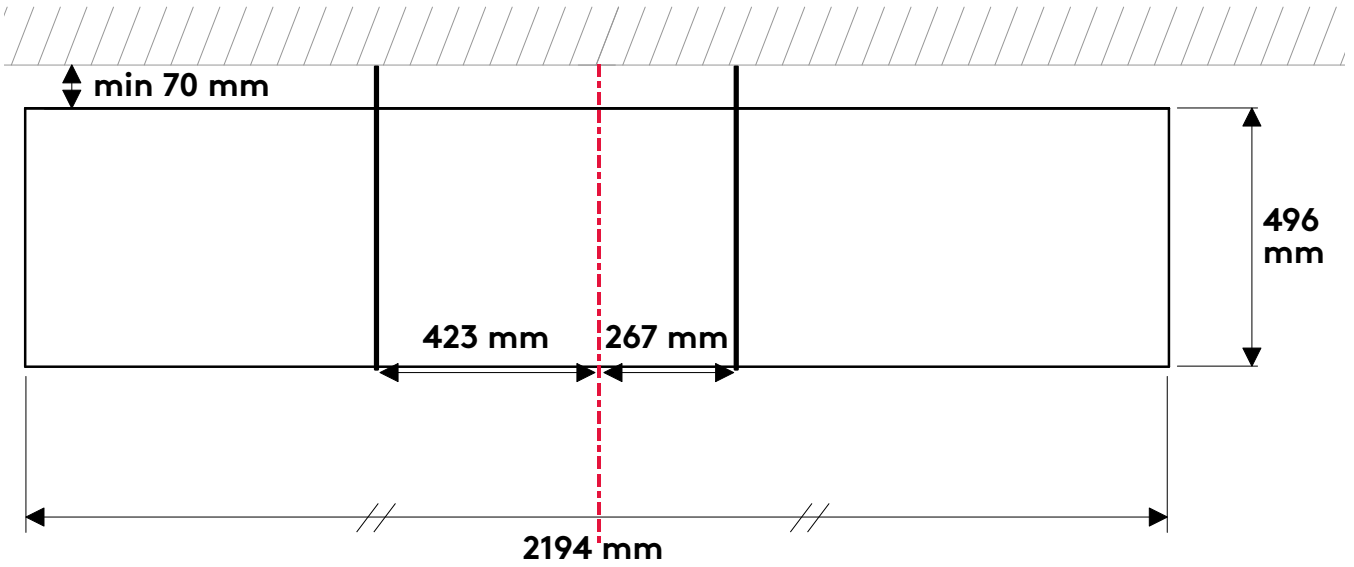
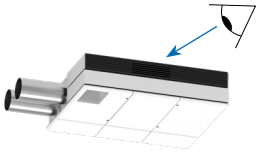

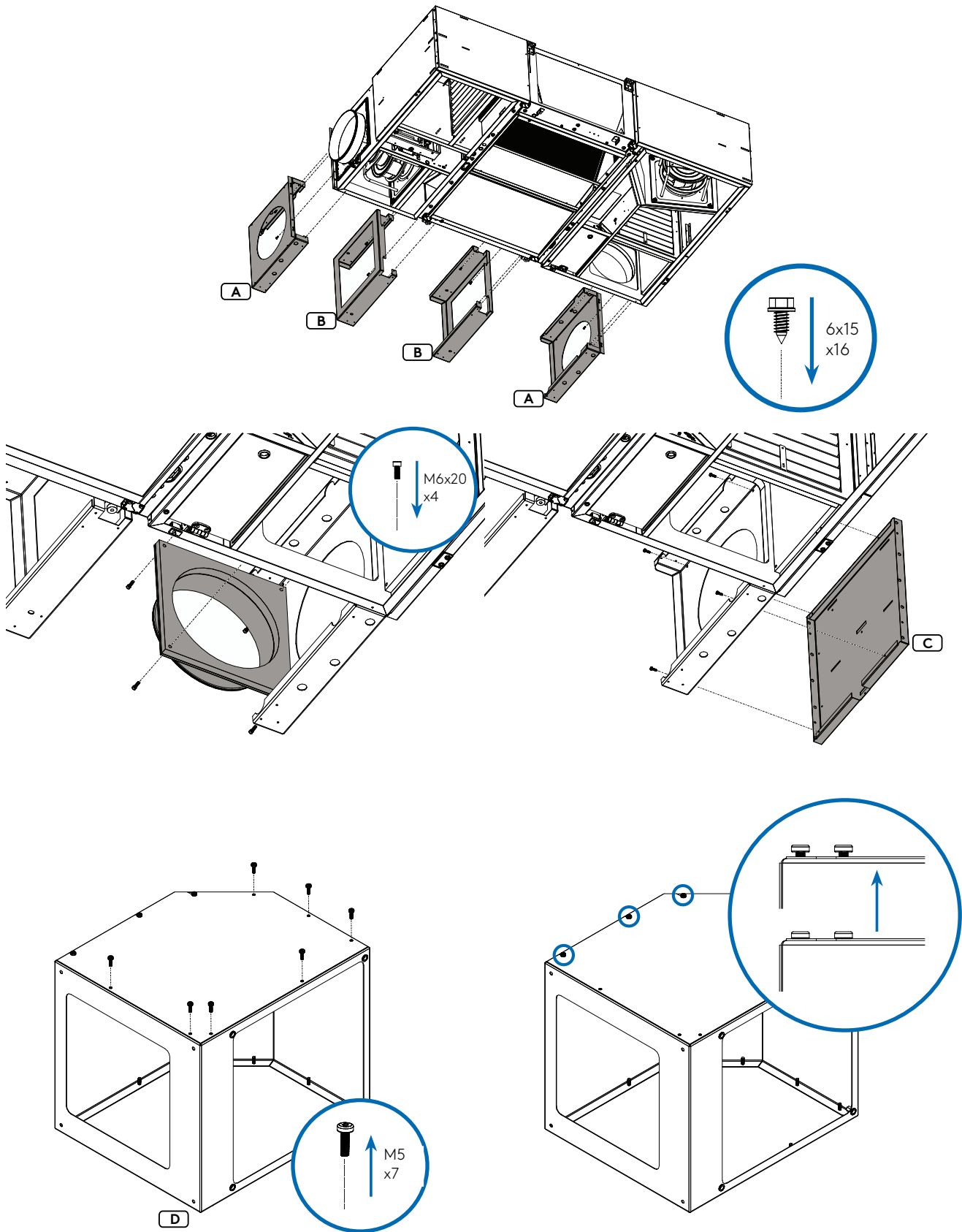

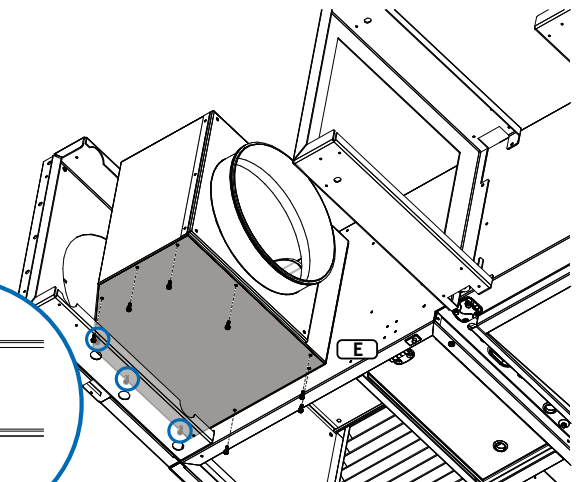
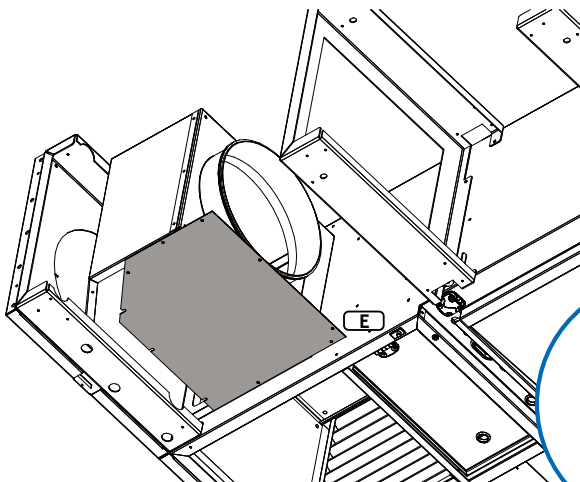
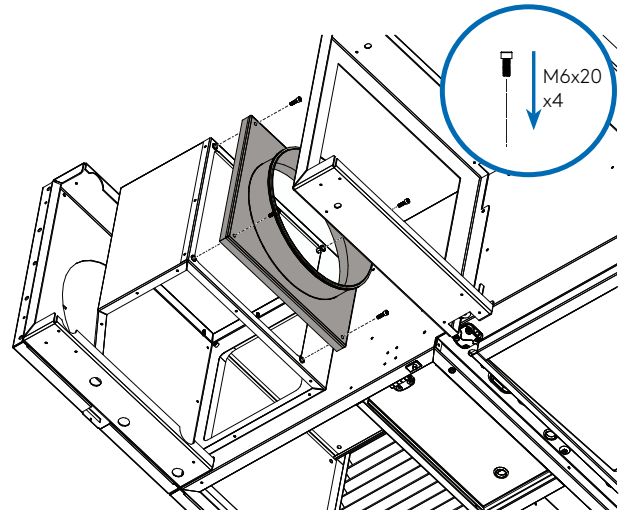
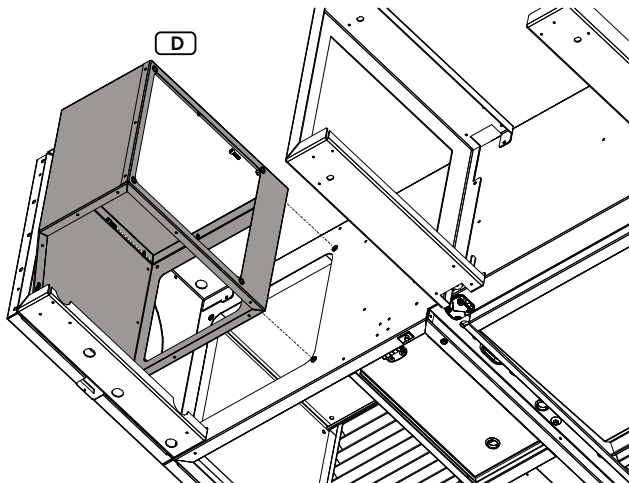
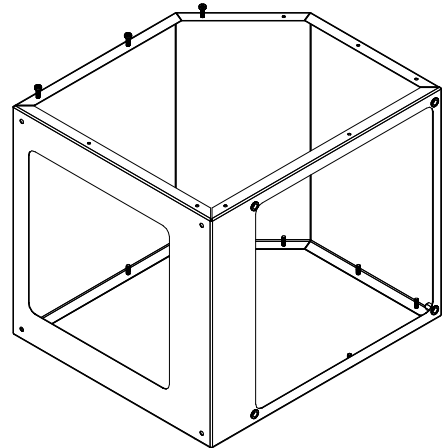
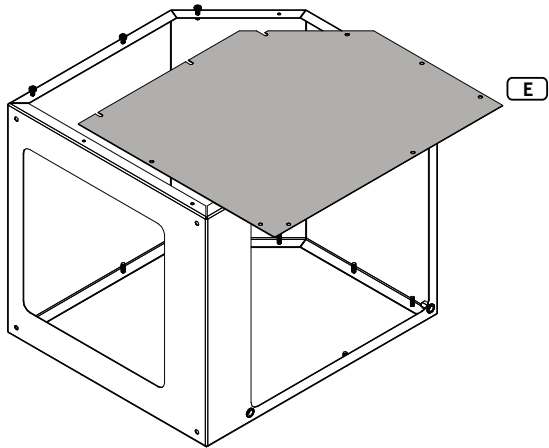

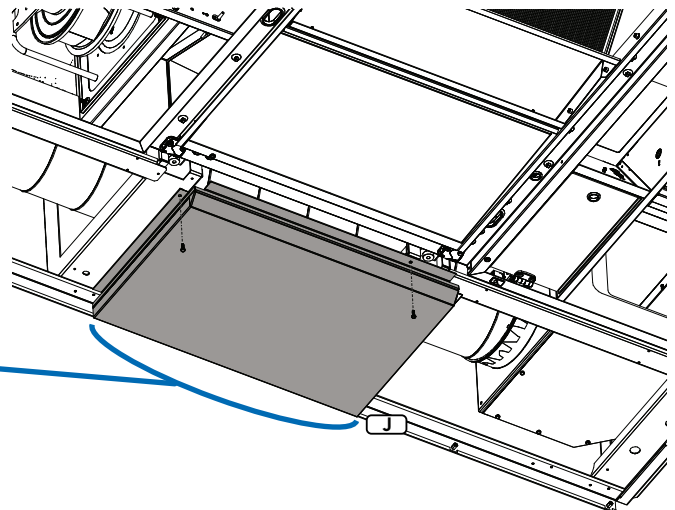
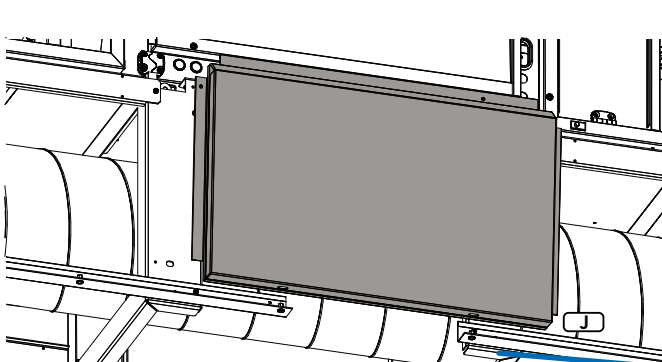
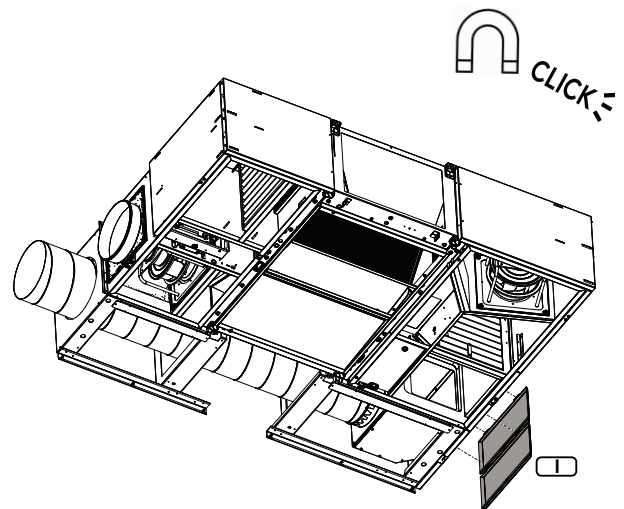
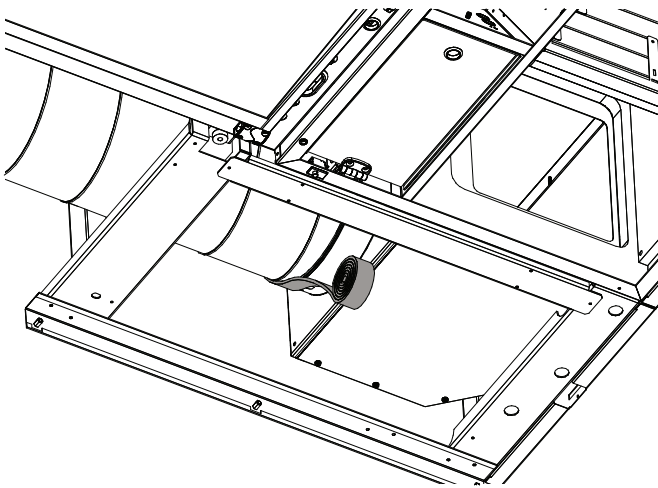
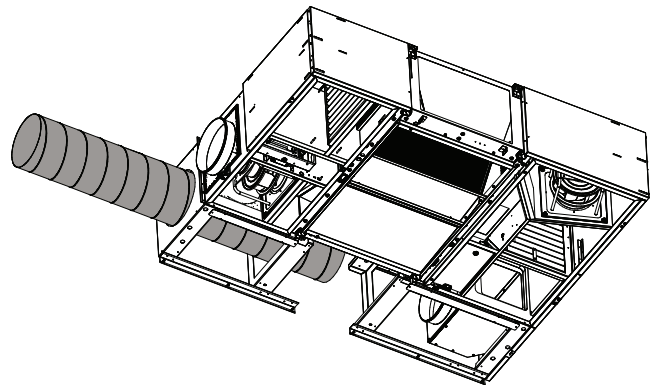
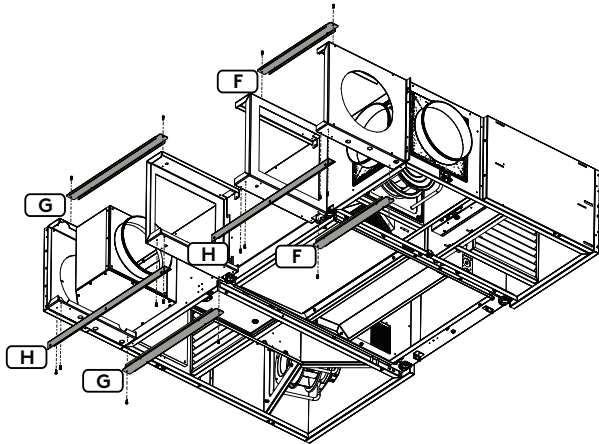

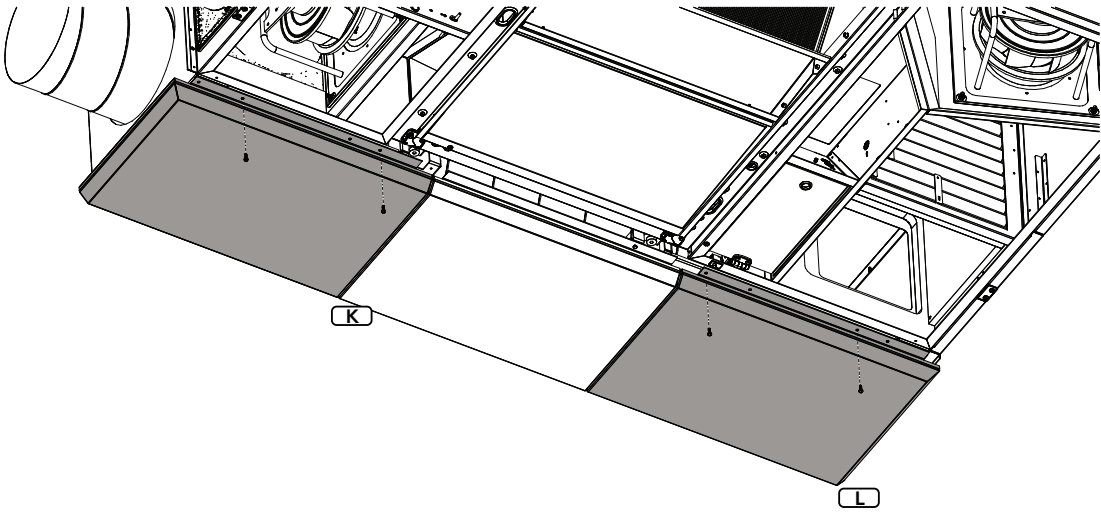

3.



EN - The four mounting points are positioned asymmetrically relative to the center of the unit.
Threaded rods ● to be used = M8

FR - Les quatre points de montage sont positionnés de manière asymétrique par rapport au centre de l'unité.
Tiges filetées ● à utiliser = M8

NL - De vier bevestigingspunten zijn asymmetrisch ten opzichte van het midden van de unit geplaatst.
Te gebruiken ● draadstangen = M8

DE - Die vier Befestigungspunkte sind asymmetrisch zur Mitte des Geräts positioniert.
Zu verwendende ● Gewindestangen: M8

IT - I quattro punti di montaggio sono posizionati in modo asimmetrico rispetto al centro dell'unità.
Barre filettate ● da utilizzare = M8

PL - Cztery punkty mocowania są ustawione asymetrycznie względem środka urządzenia.
Gwintowane ● pręty do użycia = M8

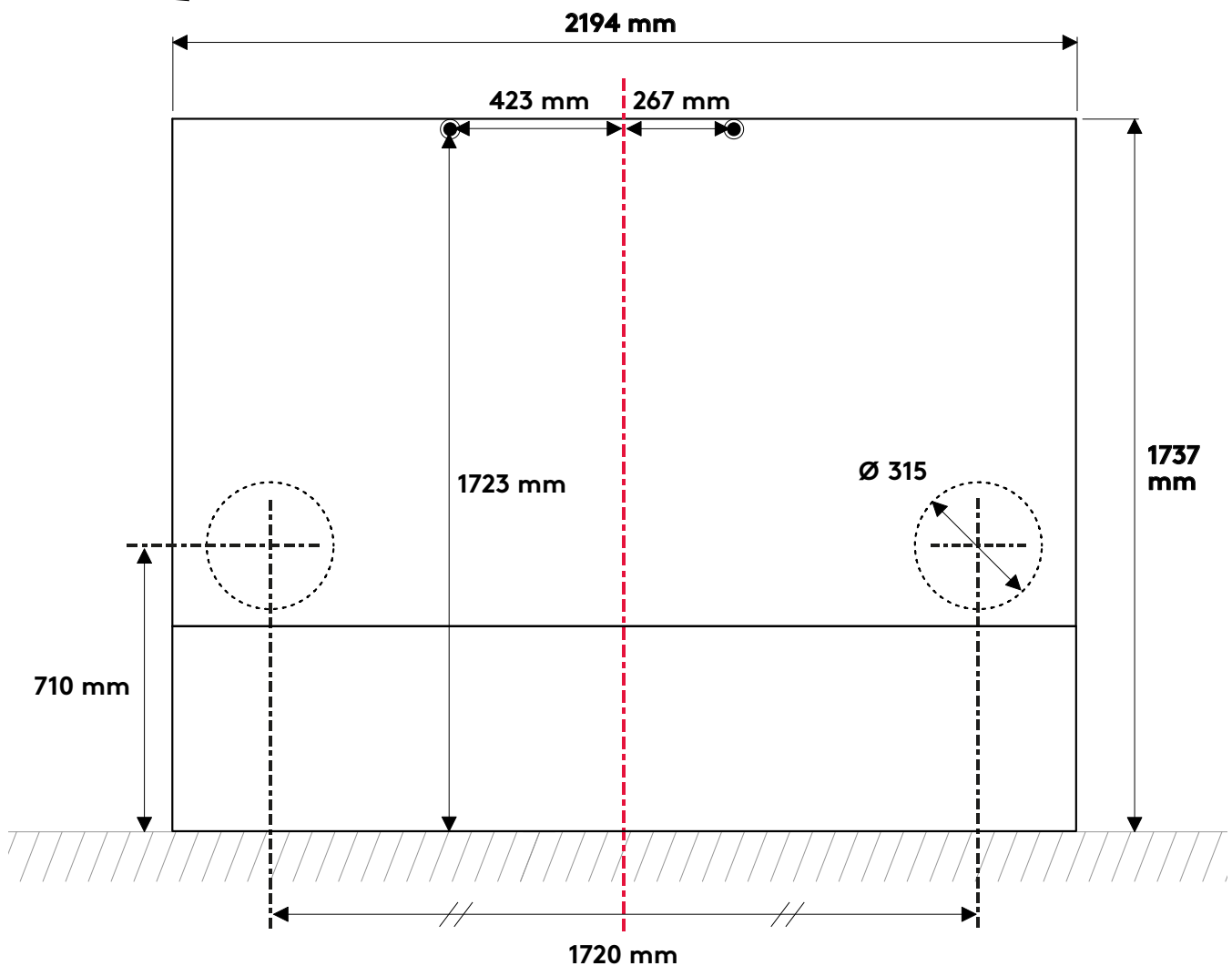

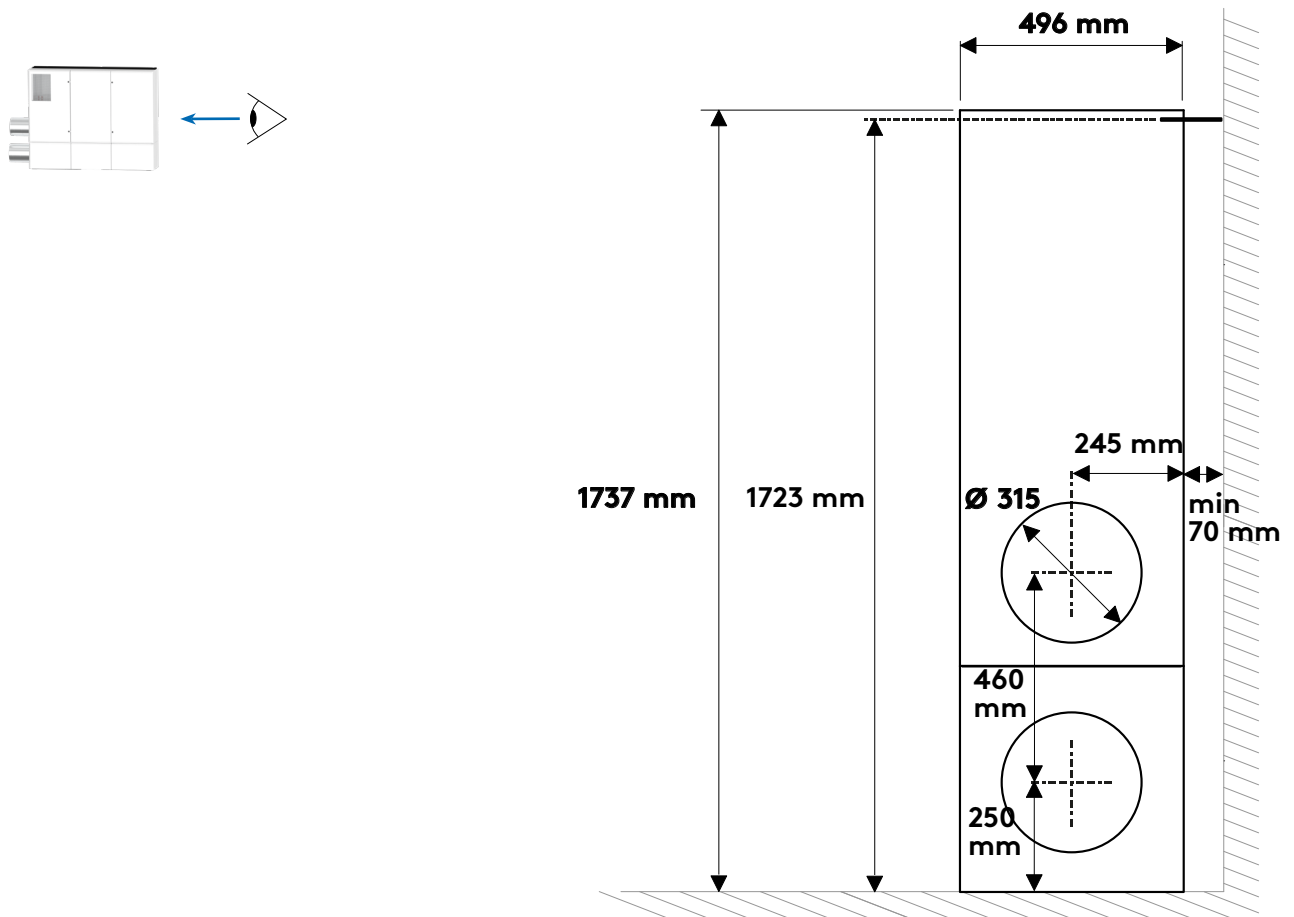
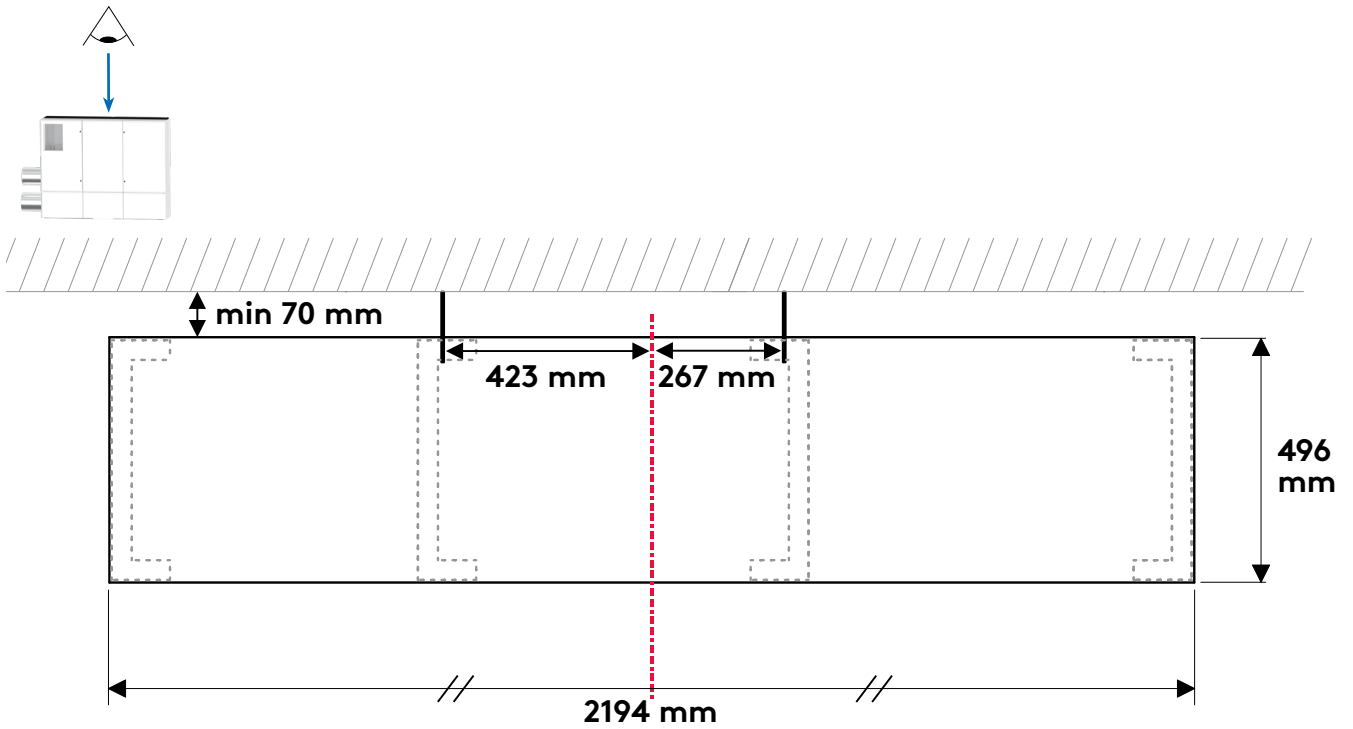

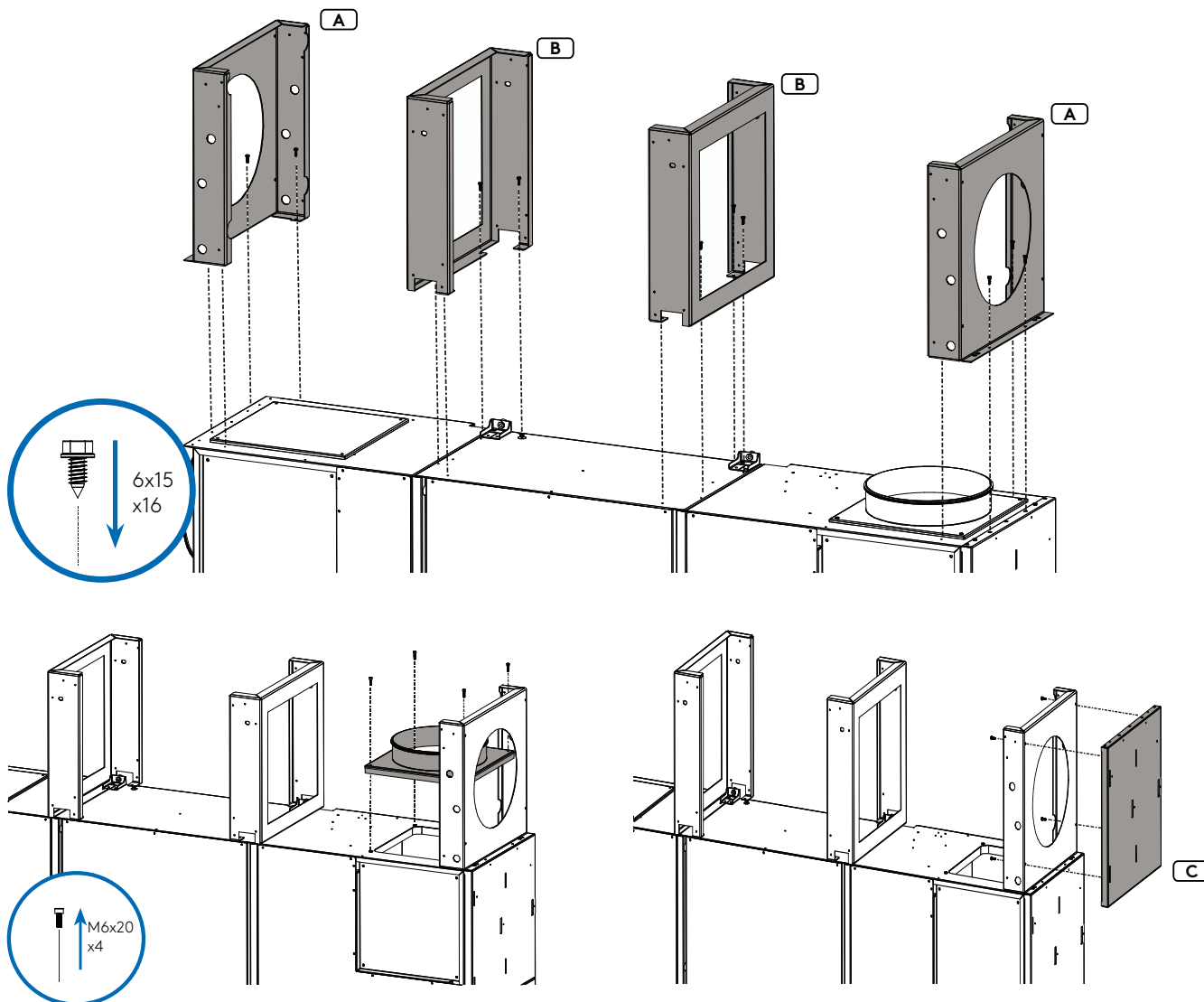

EN - Follow the installation in the main manual: §6.4.2 for 3 blocks and §6.4.3 for monobloc.

FR - Suivez l'installation décrite dans le manuel principal : §6.4.2 pour 3 blocs et §6.4.3 pour le monobloc.

NL - Volg de installatie-instructies in de hoofdhandleiding: §6.4.2 voor 3 blokken en §6.4.3 voor monoblok.

DE - Befolgen Sie die Installation gemäß dem Haupthandbuch: §6.4.2 für 3 Blöcke und §6.4.3 für Monoblock.

IT - Seguire le istruzioni di installazione nel manuale principale: §6.4.2 per 3 blocchi e §6.4.3 per monoblocco.

PL - Postępuj zgodnie z instrukcjami instalacji zawartymi w głównym podręczniku: §6.4.2 dla 3 bloków oraz §6.4.3 dla monobloku.

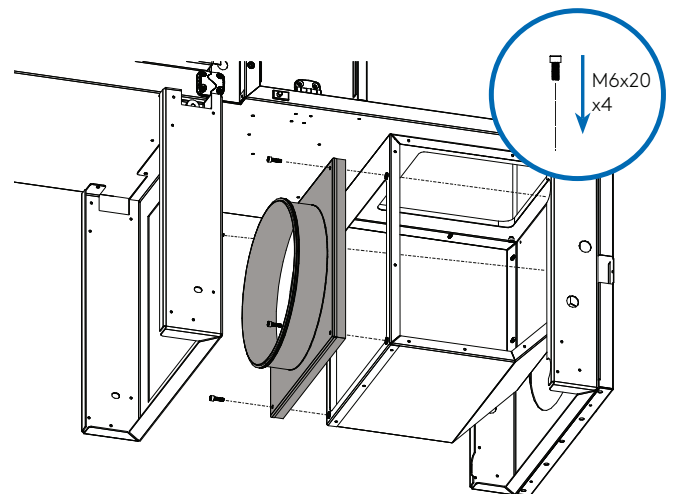
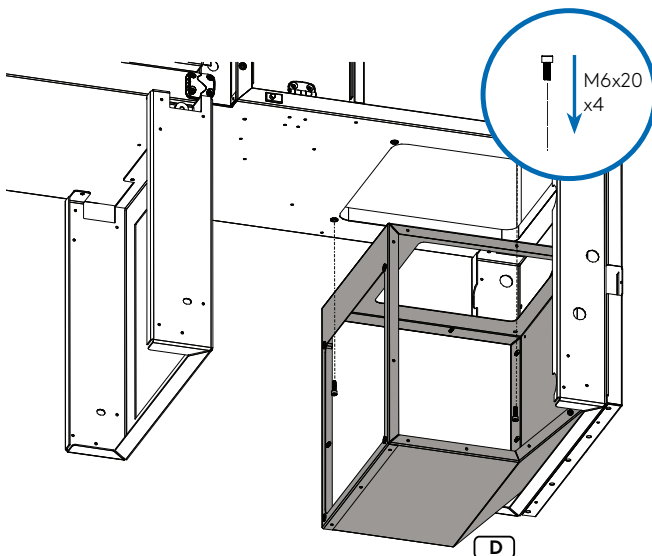
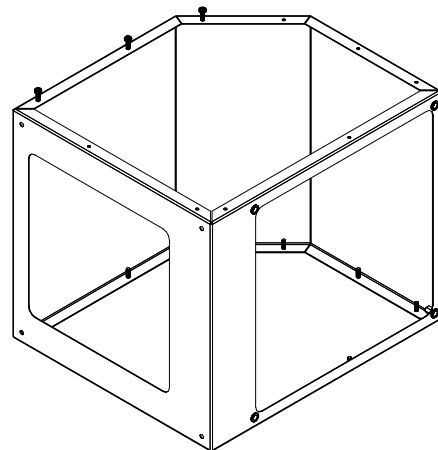
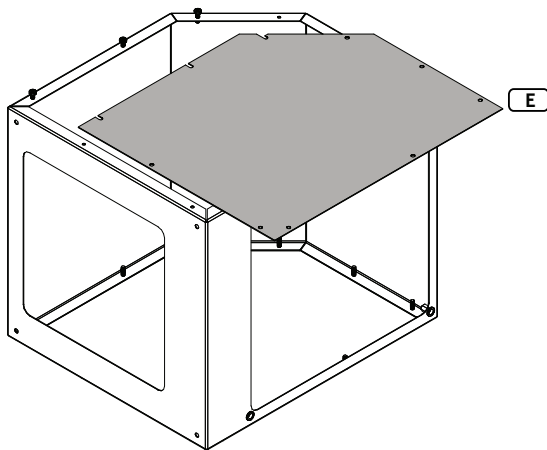
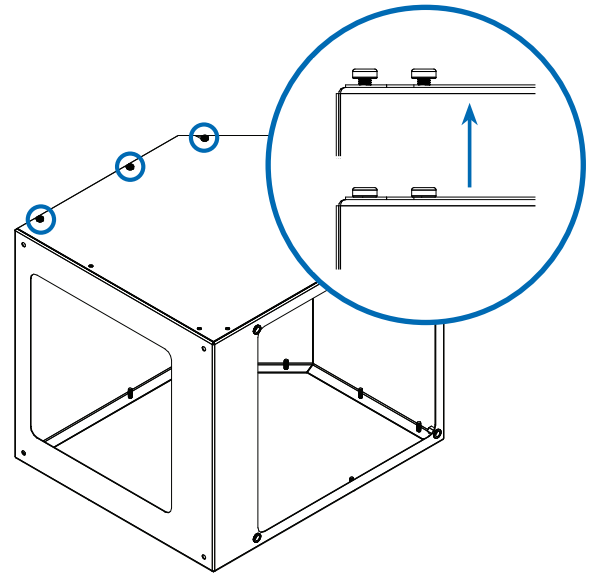
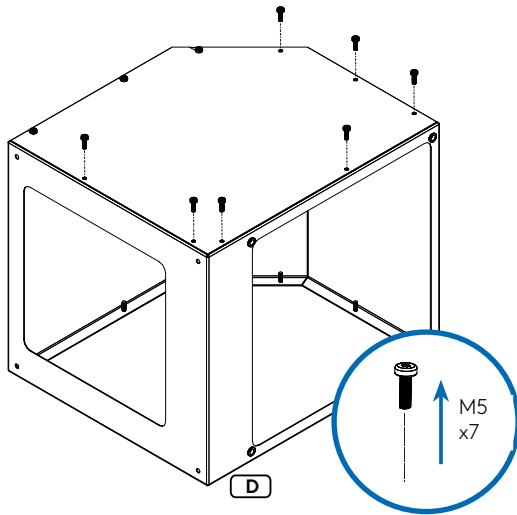

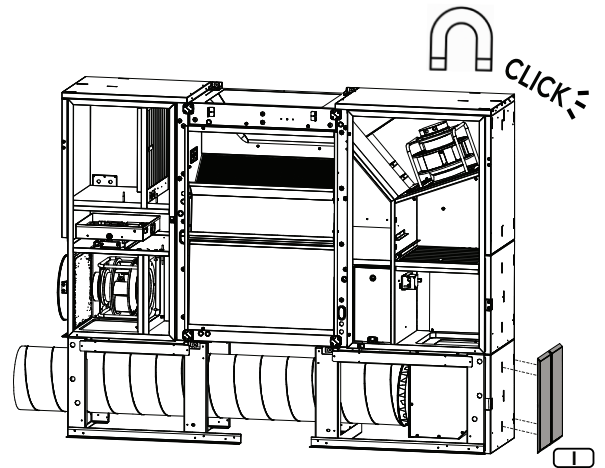
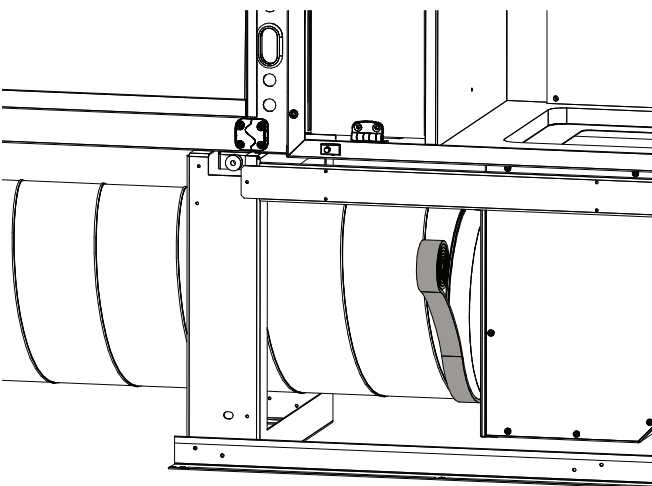
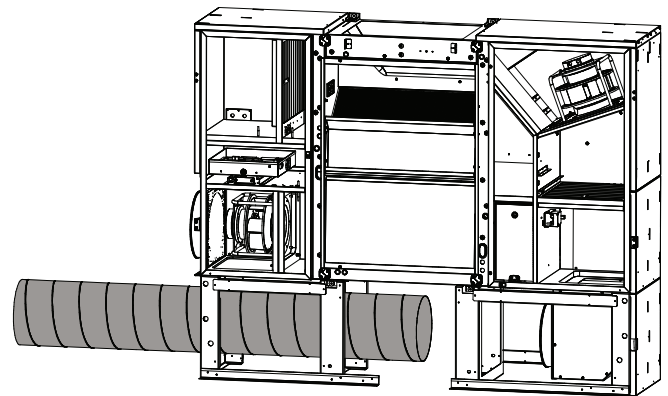
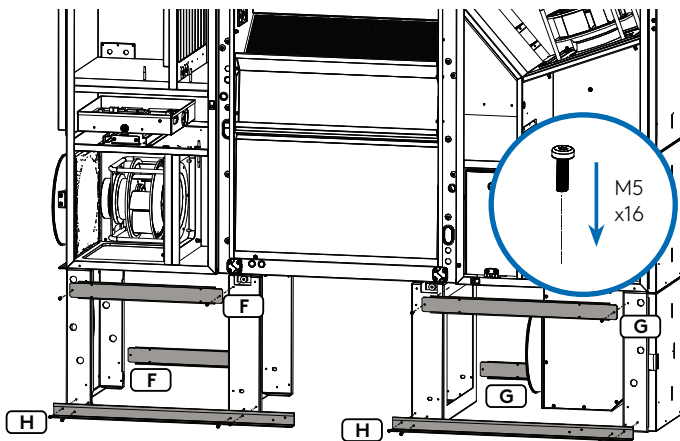
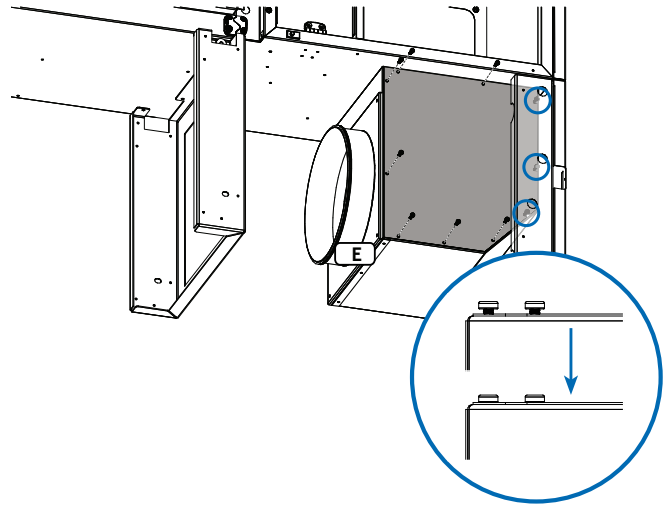
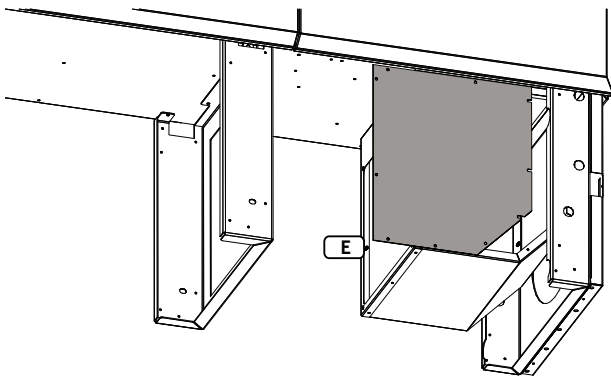

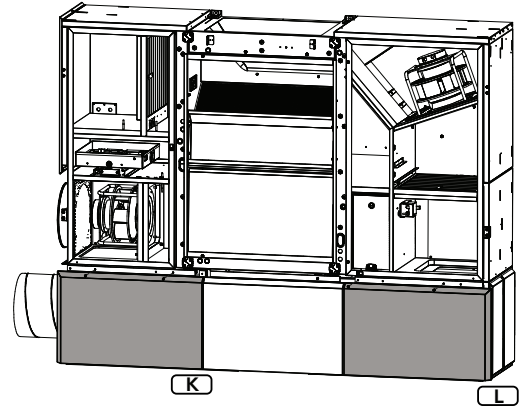
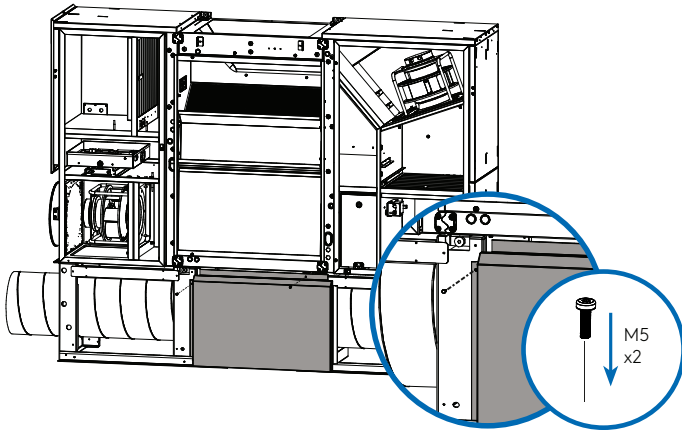
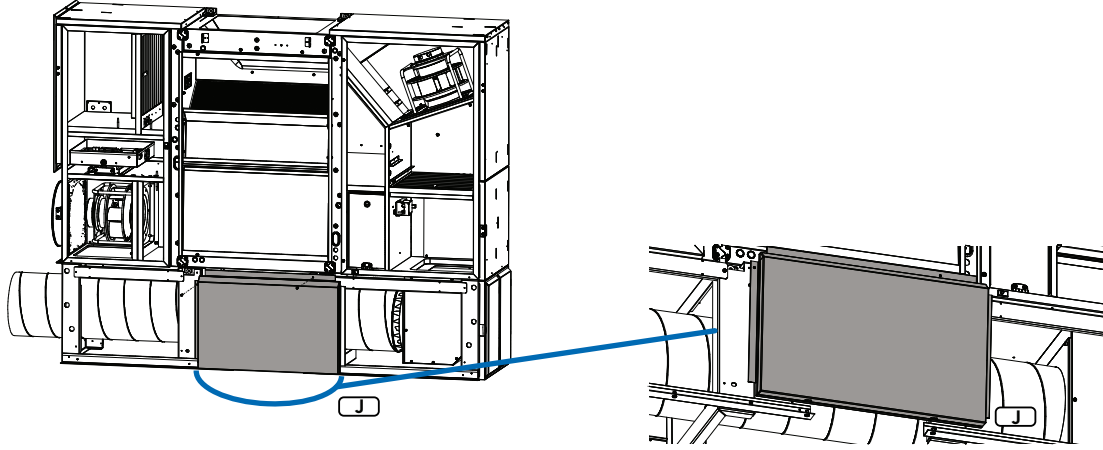

4.



EN - The four mounting points are positioned asymmetrically relative to the center of the unit.
Threaded rods ● to be used = M8

FR - Les quatre points de montage sont positionnés de manière asymétrique par rapport au centre de l'unité.
Tiges filetées ● à utiliser = M8

NL - De vier bevestigingspunten zijn asymmetrisch ten opzichte van het midden van de unit geplaatst.
Te gebruiken ● draadstangen = M8

DE - Die vier Befestigungspunkte sind asymmetrisch zur Mitte des Geräts positioniert.
Zu verwendende ● Gewindestangen: M8

IT - I quattro punti di montaggio sono posizionati in modo asimmetrico rispetto al centro dell'unità.
Barre filettate ● da utilizzare = M8

PL - Cztery punkty mocowania są ustawione asymetrycznie względem środka urządzenia.
Gwintowane ● pręty do użycia = M8

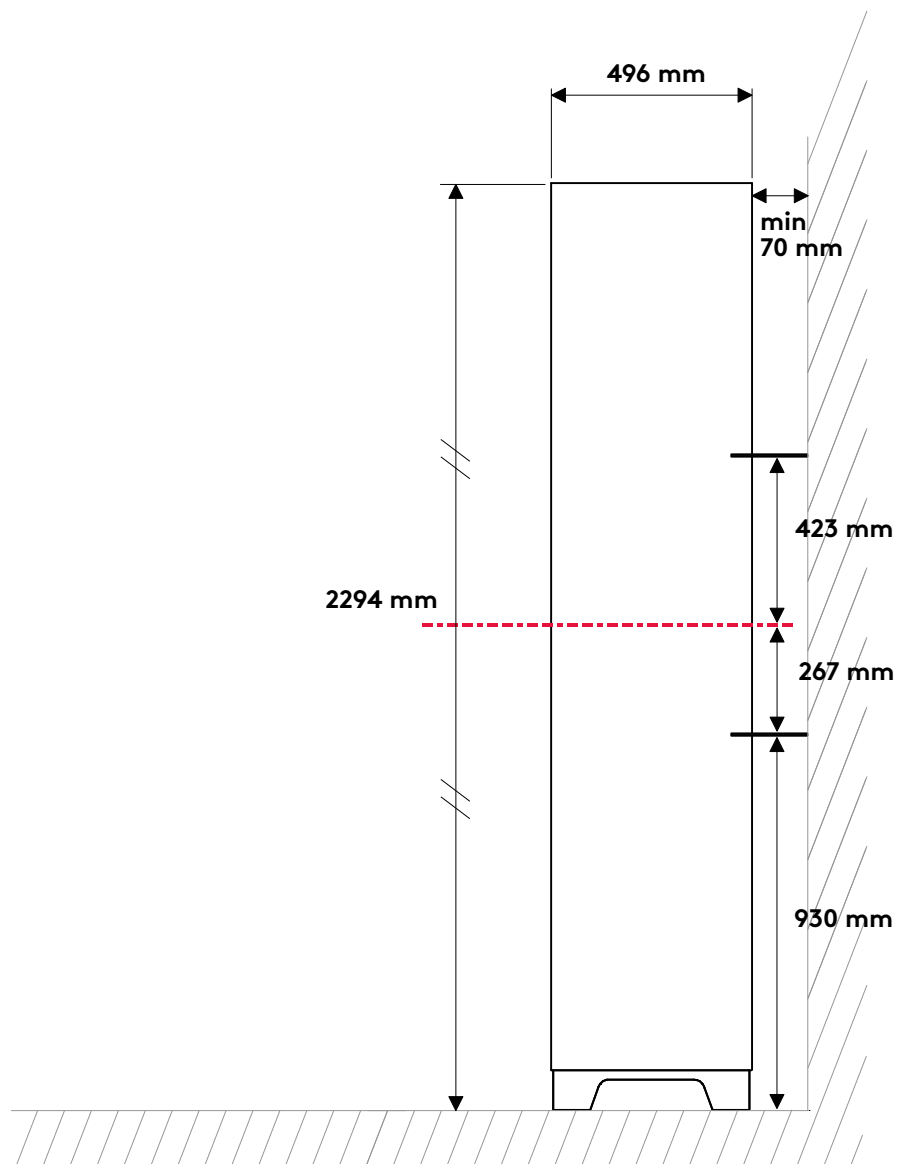

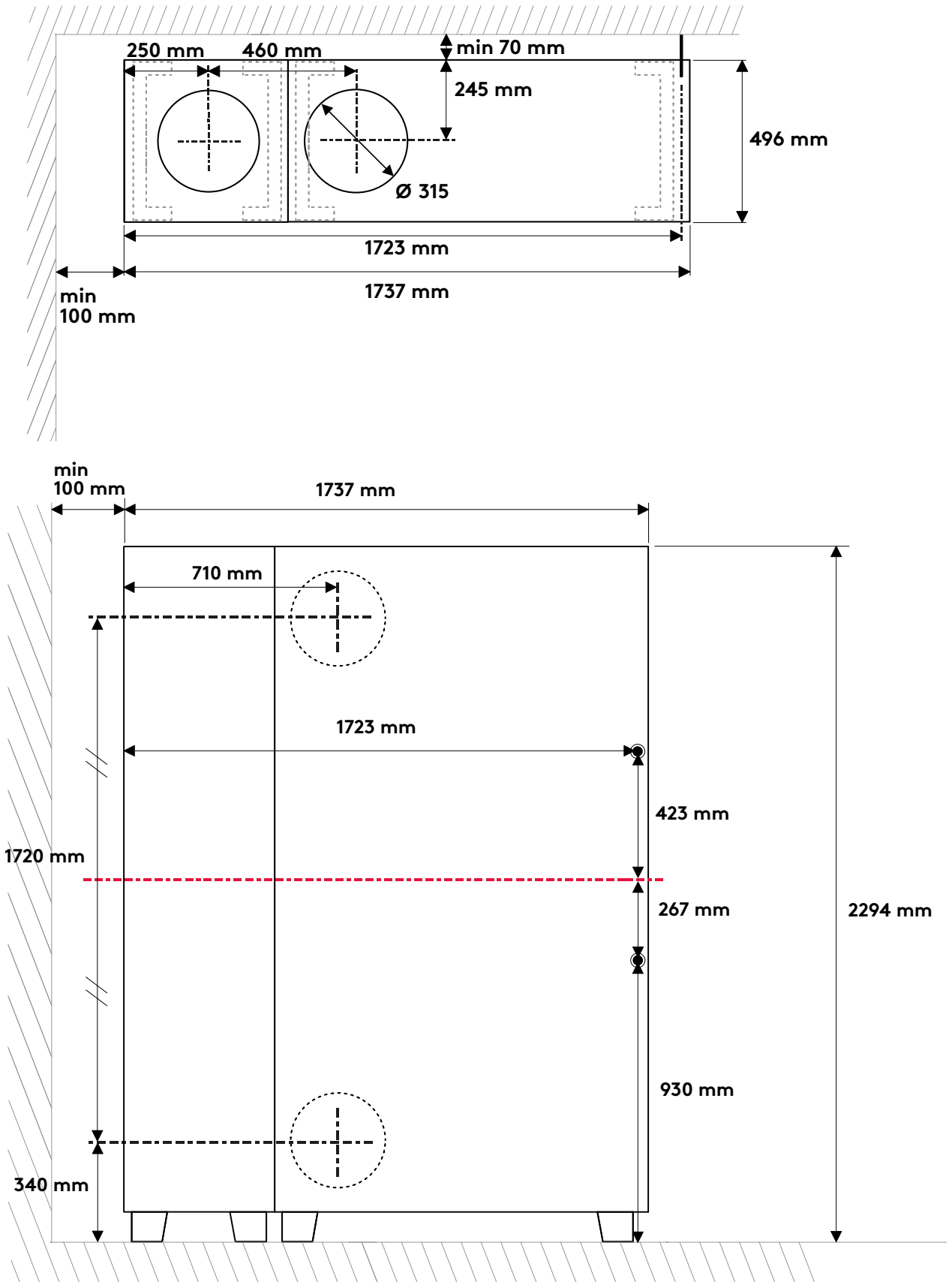

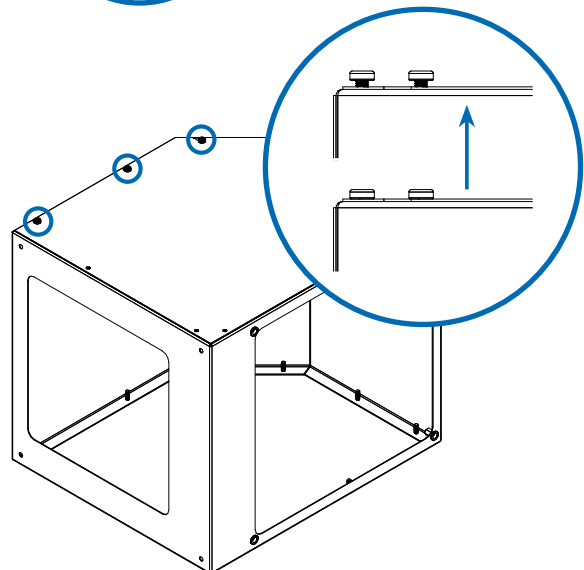
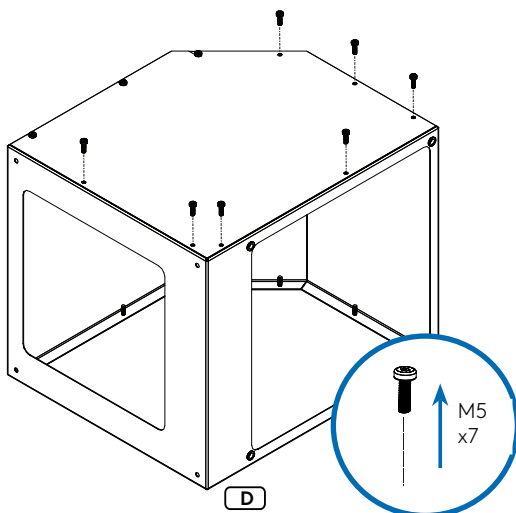
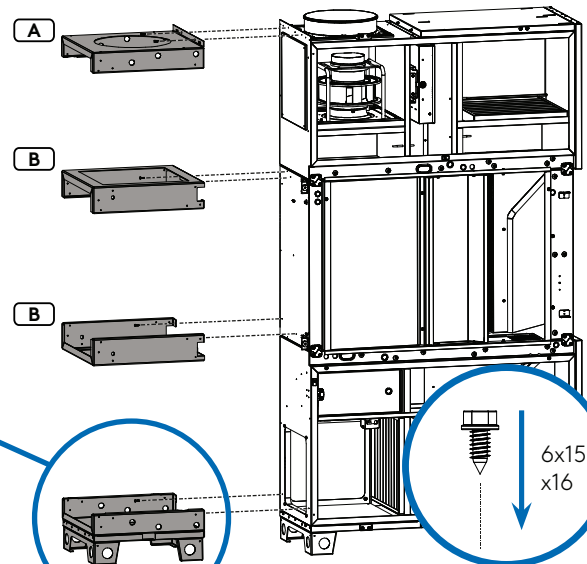
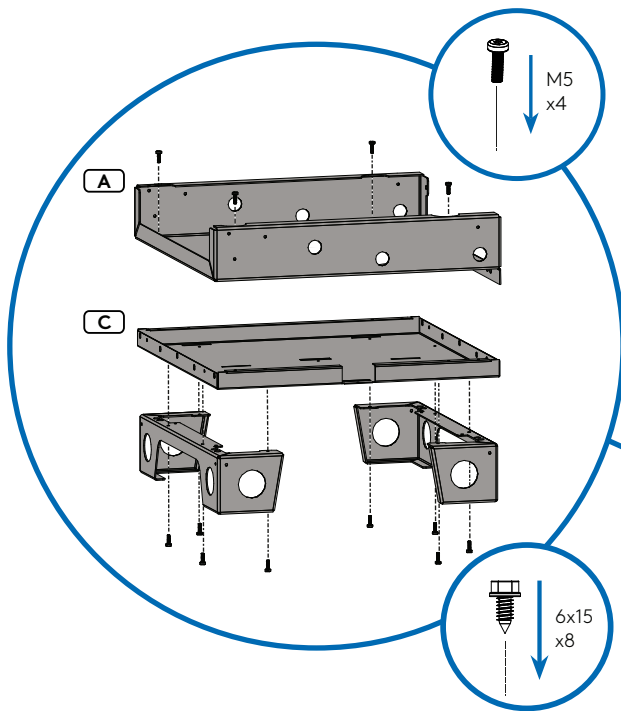
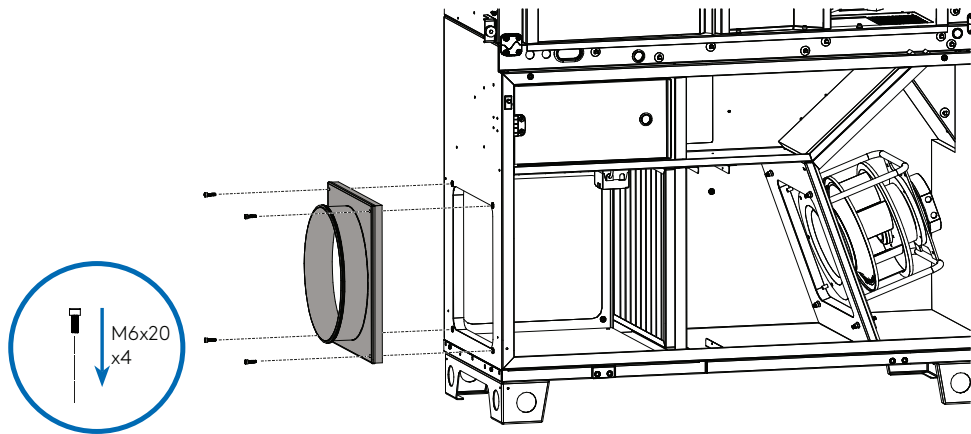

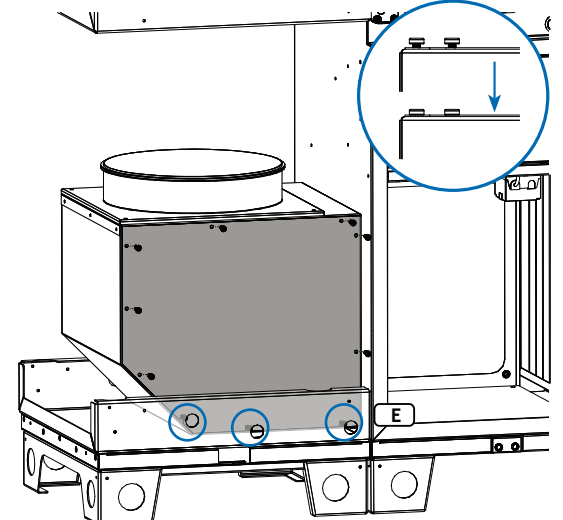
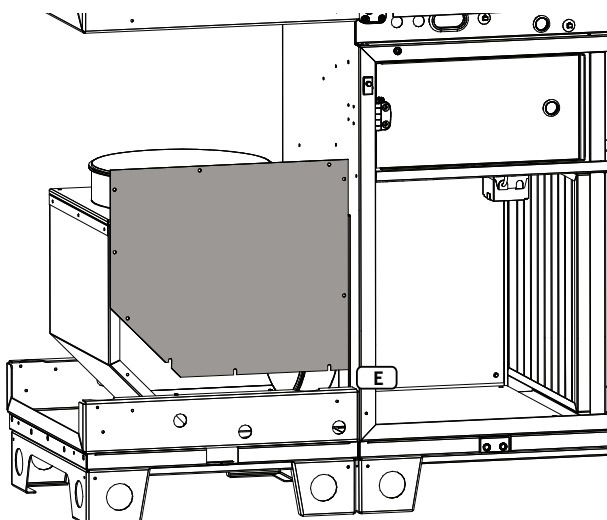
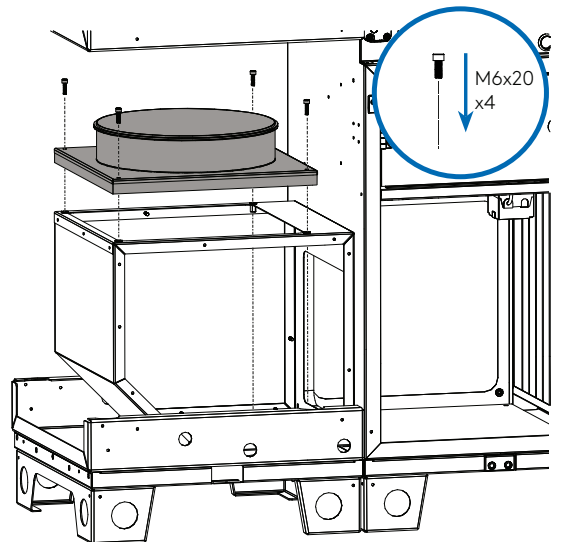
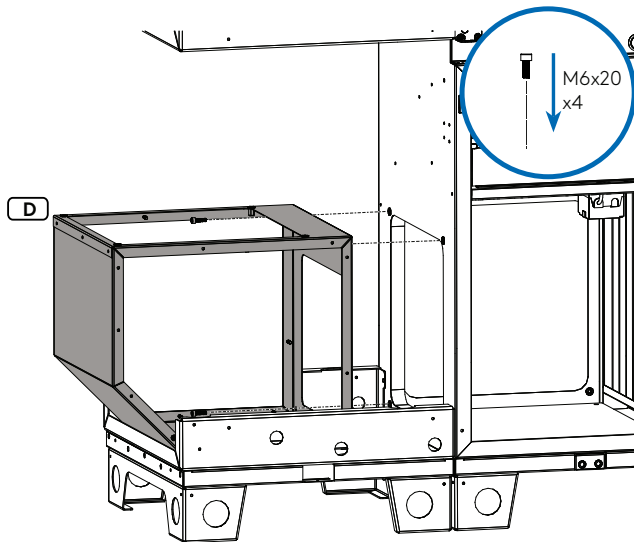
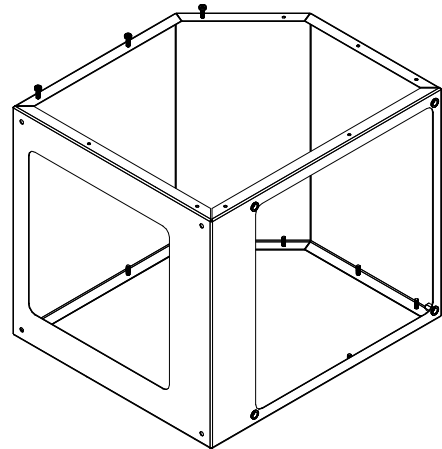
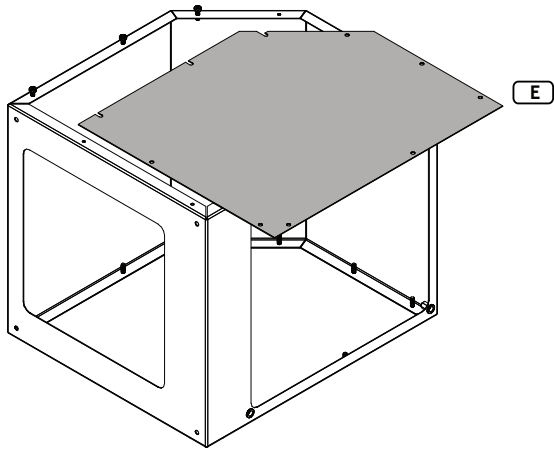

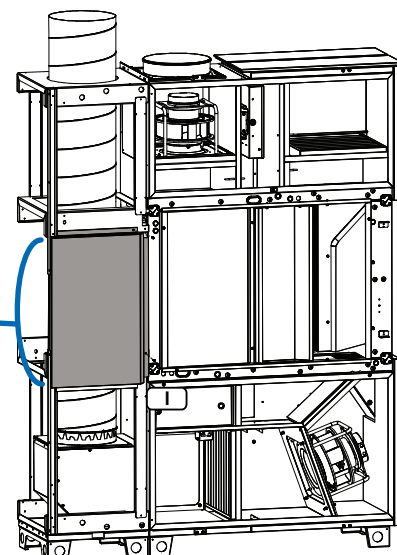
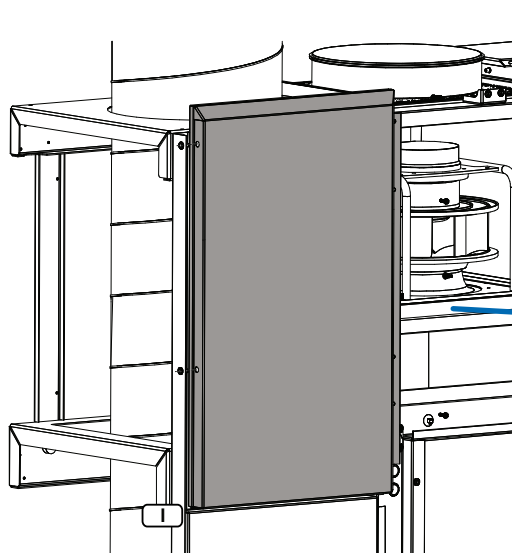
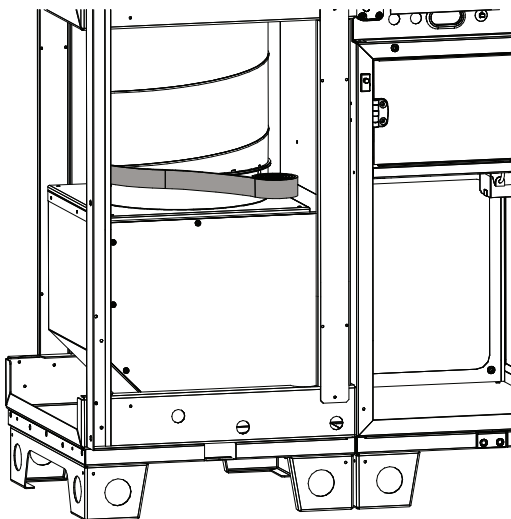
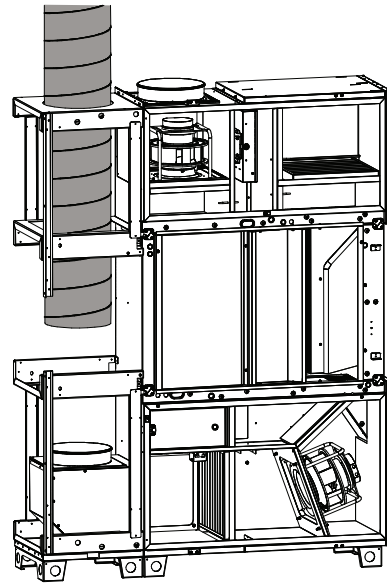
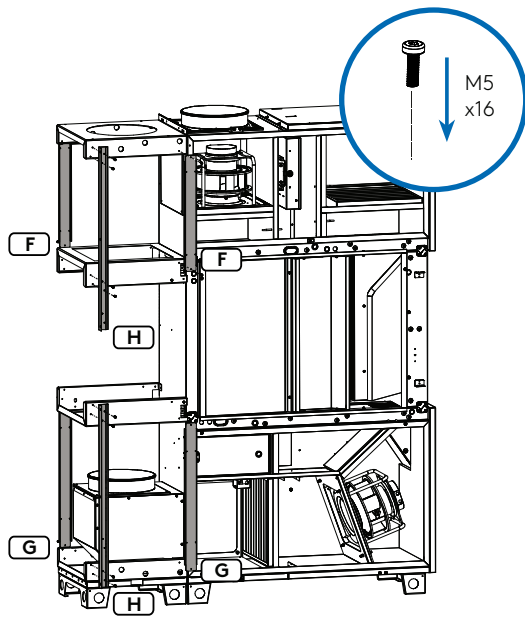

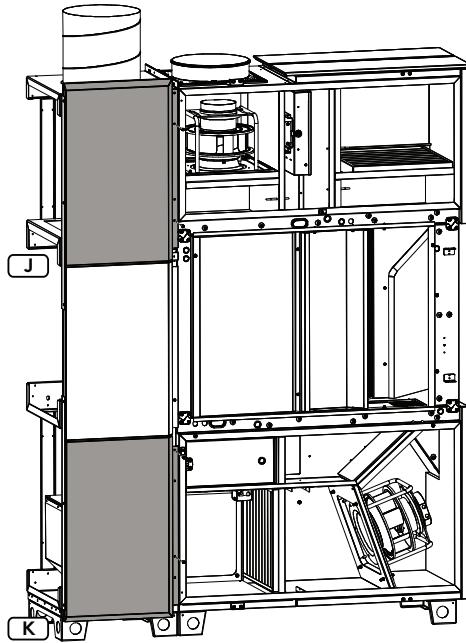

Feel good **inside**



SIDE BOX SERENITY
20260421



050564

www.swegon.com