

GOLD

Air Handling Unit

Operation & Maintenance Instructions

GOLD RX version G



Contents

1. Safety Instructions	3
1.1 Safety Isolating Switch/Main Switch	3
1.2 Risks	3
1.3 Safety Guards	3
2. General	4
2.1 Handling the air handling unit before commissioning	4
2.2 Range of Application	4
2.3 Mechanical Design	4
2.4 Control System	4
2.5 Environmental Documentation	4
2.6 The Components of the Air Handling Units	5
3. Commissioning	6
3.1 General	6
3.2 Adjusting the Duct System and air diffusers	7
3.2.1 Adjustment Sequence	7
3.2.2 Commissioning procedure	7
3.3 To Adjust the Pressure Balance	8
3.3.1 General	8
3.3.2. Ensure correct direction of air leakage	10
4. Maintenance	11
4.1 Filter change	11
4.1.1 Dismantling the filters	11
4.1.2 Installing new filters	11
4.2 Cleaning and Inspection	12
4.2.1 General	12
4.2.2 Filter spaces	12
4.2.3 Heat exchangers	12
4.2.4 Fans and fan spaces	12
4.3 Service and Functionality Check	13
4.4 Warranty	13
5. Alarms and Troubleshooting	13
5.1 General	13
5.1.1 A and B Alarms	13
5.1.2 To Reset Alarms	13
5.1.3 To Change Alarm Priority	13
6. Technical data	14
6.1 Dimensions	14
6.1.1 GOLD RX (not Top)	14
6.1.2 GOLD RX Top	20
6.2 Connection to Wiring Terminals	23
6.3 Electrical Data	24
6.3.1 Air Handling Units	24
6.3.1.1 Size 004-012	24
6.3.1.2 Size 014-120	25
6.3.2 Fans	27
6.3.3 Electrical equipment cubicle	28
6.3.3.1 Size 004-012	28
6.3.3.2 Size 014-120	29
6.3.4 Motor in rotary heat exchanger	30
6.3.4.1 Rotor standard	30
6.3.4.2 Rotor Recosorptic	30
6.3.5 Control inaccuracy	30
6.3.6 EMC	30
7. Appendices	31
7.1 Declaration of Conformity	31
7.2 Building Materials Declaration	31
7.3 License	31
7.4 Ecodesign data	32
7.5 Digital Services	33

The document was originally written in Swedish.

1. Safety Instructions

All staff concerned must acquaint themselves with these instructions before beginning any work on the unit. Any damages to the unit or parts of it due to improper handling or misuse by the purchaser or the fitter cannot be considered subject to guarantee if these instructions have not been followed correctly.



Warning

Only a qualified electrician or service personnel trained by Swegon shall be permitted to carry out any work on the electrical system or wire external functions in the air handling unit.

1.1 Safety Isolating Switch/ Main Switch

On the size 004/005, 007/008, 011/012, 014/020 and 014+/020+ units, the safety isolating switch is externally located on the connection hood.

On the size 025/030, 025+/030+, 035/040, 050/060, 070/080, 070+/080+ and 100/120 units, the safety isolating switch is externally located on the centre section of the unit.

The air handling unit should normally be started and stopped from the hand-held terminal; not by switching the safety isolating switch on and off.

Always switch off the safety isolating switch before servicing the unit if not otherwise specified in the pertinent instructions.

1.2 Risks



Warning

Before carrying out any work, make sure that the power supply to the air handling unit has been switched off.

Risk areas with moving parts

Typical moving parts are fan impellers and drive pulleys of the rotary heat exchanger.

The lockable inspection doors serve as protection from contact with the fans and protection for the heat exchanger. If the ducts are not firmly connected to the fan outlets, the outlets must be firmly fitted with a safety guard (wire mesh screen).



Warning

The inspection doors on the filter/fan sections must not be opened while the unit is operating.
Stop the unit operating normally via the hand-held micro terminal.
Wait until the fans have stopped before opening the door.
There is positive pressure inside the fan section which could cause the door to fly open.
Keep the key at a safe spot separate from the air handling unit.

1.3 Safety Guards

The cover of the electrical equipment cubicle and the connection hood serve as safety guards on the size 004/005 and 008 units. On the size 012, 014/020, 014+/020+, 025/030, 025+/030+, 035/040, 050/060, 070/080, 070+/080+ and 100/120 units, the lockable door over the electrical equipment cubicle, and if applicable, the connection hood serve as safety guards.

Only a qualified electrician or trained service technicians shall be allowed to remove the safety guards.



Warning

The power supply to the unit shall be isolated by switching off the safety isolating switch before removing the safety guard.

When the air handling unit is operating, the safety guards must always be mounted, all inspection doors must be closed, and the junction hood on the top of the unit must be mounted.

2. General

2.1 Handling the air handling unit before commissioning

The air handling unit and its duct connections should be protected against wetness and condensation until the unit is commissioned.

2.2 Range of Application

The GOLD units are designed for use in comfort ventilation applications. Depending on the variant selected, GOLD units can be utilised in buildings such as office buildings, schools, day nurseries, public buildings, shops, residential buildings, etc.

In order to fully obtain all the benefits the GOLD system has to offer, it is important to take the special characteristics of the air handling units into account when planning them into the project, installing, commissioning and operating them.

The air handling unit in its basic design should be installed indoors. The TBTA/TBTB accessory should be used if the air handling units are installed outdoors. If the duct accessories are installed outdoors, they must be housed in an insulated casing (type TCxx).

GOLD RX is designed and tested for temperatures, in the surroundings and the air stream, from -40°C to $+40^{\circ}\text{C}$, however, the temperature difference between the outdoor air and extract air must not exceed 70°C .

The fans are approved for continuous operation in temperatures of up to 40°C .

The fans are tested for, and can manage operation for one hour at 70°C .



Important!

Always read the safety instructions in Section 1 that explain the risks involved in running the unit and designate who shall be permitted to operate and service the unit, and carefully follow the installation instructions provided in each paragraph.

The product identification plates are located on the inspection side of the air handling unit and on a wall inside the fan section. Refer to the particulars on the product identification plate when you contact Swegon.

2.3 Mechanical Design

The GOLD is available in 12 physical sizes and for 24 airflow ranges.

GOLD RX Top size 004-012 is equipped with pleated filters ePM10 60% (M5) or ePM1 50% (F7). Other sizes/variants have supply air filters and extract air filters made of glass fibre in filter class ePM10 60% (M5) or ePM1 60% (F7).

The type RECOmomic rotary heat exchanger is variable speed controlled.

The supply air and extract air fans are of GOLD Wing+ type, an axi-centrifugal fan with backward-curved blades. The fans are direct-driven and have a motor control system for variable speed control.

2.4 Control System

The IQlogic control system is microprocessor-based and is integrated into the air handling unit. It controls and regulates the fans, heat exchanger, temperatures, airflows, Operation times and a large number of internal and external functions as well as alarms.

2.5 Environmental Documentation

For a complete Declaration of Construction Materials, see our home page at www.swegon.com (applicable to Sweden only).

The air handling unit is designed in such a way that it can be easily dismantled into its component parts. When the unit has ended its useful product life, the services of an accredited recycling company should be utilised for disposal.

The recyclable weight of the GOLD is about 94% of its initial weight.

Swegon AB is associated with the REPA Register, No. 5560778465.

Contact Swegon AB, Phone: +46 (0)512-322 00, if you have any questions regarding the dismantling instructions or the air handling unit's impact on the environment.

2.6 The Components of the Air Handling Units

The individual components are each specified below in a simplified and diagrammatical description.

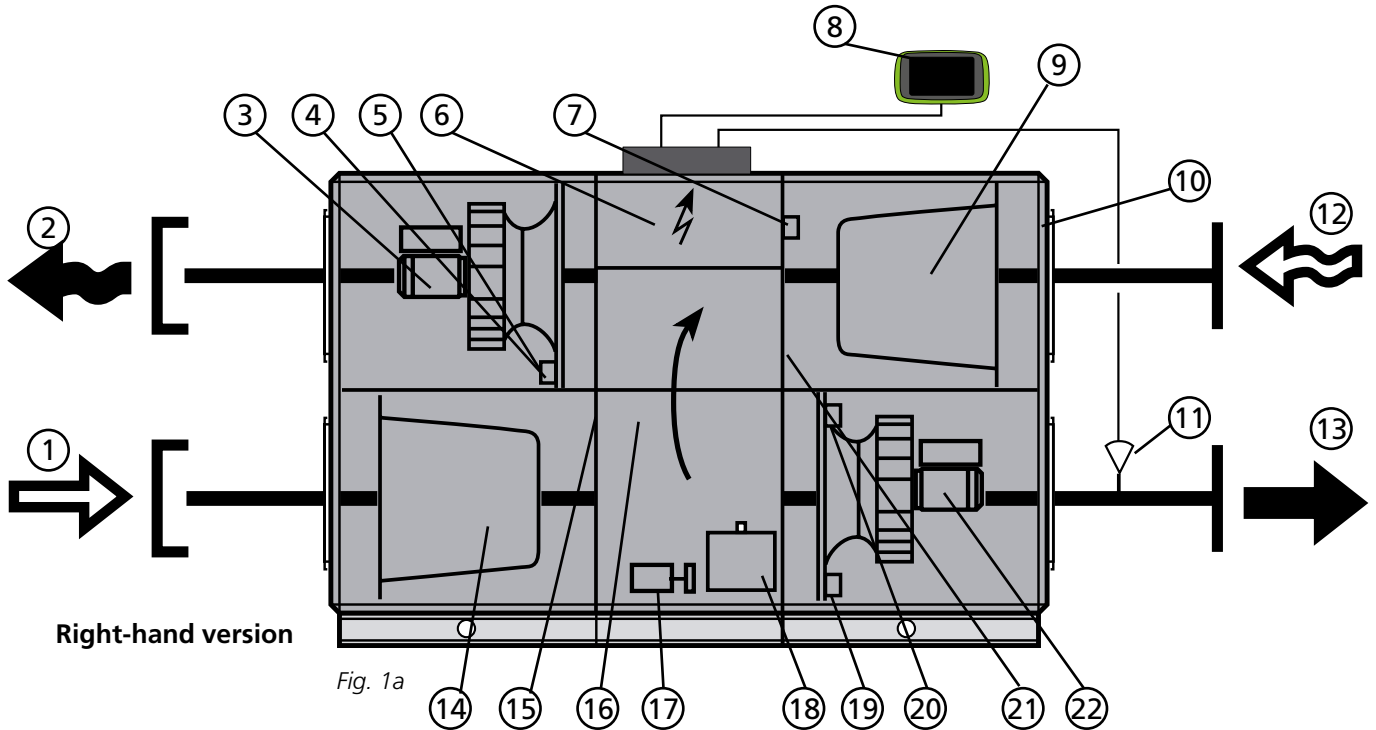

Fig. 1a

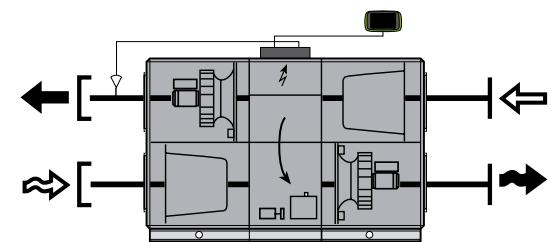
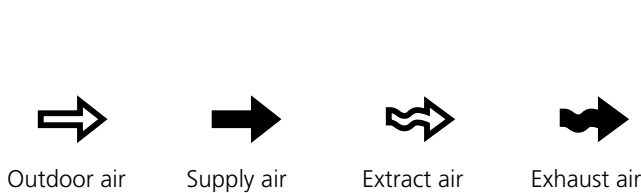

Fig. 1b

Left-hand version

GOLD 004-120: The air handling units can be ordered in the right-hand version as shown in Fig. 1a or in the left-hand version as shown in Fig. 1b.

GOLD 012-120: The air handling unit according to Fig. 1a shows Fan Arrangement 1. The unit can also be ordered according to Fan Arrangement 2. The fans and filters are then vertically mirror-inverted.

In the left-hand version (Fig. 1b), the components marked with an asterisk change function and designation (the components are named according to whether they are for supply air or extract air).

The arrangement of the components and their designations

- 1 OUTDOOR AIR* (In left-hand version: Extract air)
- 2 EXHAUST AIR* (In left-hand version: Supply air)
- 3 Extract air fan* with motor and motor controller
- 4 Sizes 004-060: Pressure sensor, extract air fan* and pressure sensor, supply air filter*
Sizes 070-120: Pressure sensor, extract air fan*
- 5 Sizes 004-060: None (see item 4)
Sizes 070-120: Pressure sensor, supply air filter*

- 6 Electrical equipm. cubicle with control unit
- 7 Pressure sensor of the heat exchanger
- 8 Hand-held terminal IQnavigator
- 9 Extract air filter*
- 10 Commissioning plate (Left-hand unit version - by left-hand filter section)
- 11 Temperature sensor, supply air (to be mounted in supply air duct)
- 12 EXTRACT AIR* (In left-hand version: Outdoor air)
- 13 SUPPLY AIR* (In left-hand version: Exhaust air)
- 14 Supply air filter*
- 15 Temperature sensor, outdoor air*
- 16 Heat exchanger
- 17 Drive motor, heat exchanger
- 18 Control unit heat exchanger, with integrated rotation monitoring
- 19 Sizes 004-060: Pressure sensor, supply air fan* and pressure sensor, extract air filter*
Sizes 070-120: Pressure sensor, supply air fan*
- 20 Sizes 004-060: None (see item 19)
Sizes 070-120: Pressure sensor, extract air filter*
- 21 Temperature sensor, extract air*
- 22 Supply air fan* with motor and motor controller

3. Commissioning

3.1 General

Commissioning sequence:

1. Check that there are no foreign objects inside the unit, duct system or functional sections.
2. Check that the rotary heat exchanger rotor rotates easily. On sizes 050-120, the rotary heat exchanger must be angled slightly towards the filter, see drawing below.

If the inclination needs adjusting, see special instructions for adjusting the inclination of the rotary heat exchanger (004-080) or the installation instructions for the GOLD (120).

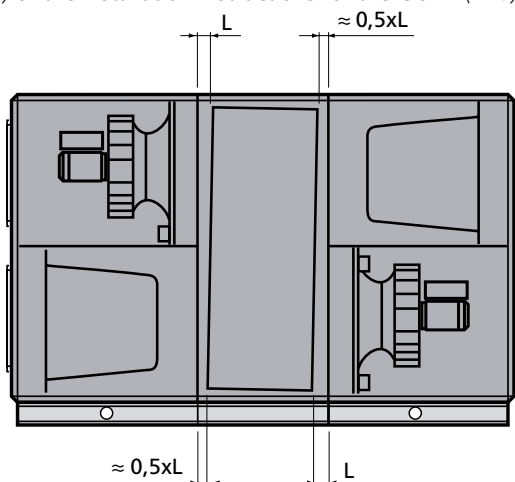

GOLD RX, sizes 050-120: The illustration shows the factory-preset rotor inclination in a unit with Fan Arrangement 1. The inclination must always be towards the filter, which means that the inclination for Fan Arrangement 2 is in the other direction.

3. Turn the safety isolating switch to the ON position (I).
4. Select the appropriate language, if you have not already done so. See Section 4.7 in the GOLD Function Manual, Installation

5. The air handling unit has a factory setting that makes it ready to operate. See separate Commissioning Record.

However, in many cases, these settings need to be adjusted to suit the current installation.

If necessary, enter the fan position setting (inspection side), see Section 4.10 in the Function Manual, Installation.

Program the time switch, operating mode, temperatures, airflows and functions according to the procedures in Section 4 in the Function Manual, Installation.

Select whether the airflow unit of measurement shall be l/s, m³/s, m³/h or cfm.

Fill out the Commissioning Record and save it in the document pocket of the air handling unit.

In some cases it might be necessary to adjust the P-band and the I-time if the heating regulation system is oscillating or operates sluggishly. This requires entering a special code. Contact your Swegon representative.

6. Activate, if needed, manual or auto operation (Dashboard) or lock the speed of the fans (AIRFLOW ADJUSTMENT image). Adjust the duct system and the air diffusers according to Section 3.2.
7. Check and adjust, if required, the pressure balance in the air handling unit according to Section 3.3.
8. Finish with filter calibration according to Section 3 in the Function Manual, Installation.

3.2 Adjusting the Duct System and air diffusers

In order to prevent the fans from consuming more power than necessary, it is important to keep the pressure drop in the system at the lowest possible level. It is also important that duct systems and air diffusers are correctly commissioned to provide the comfort expected.

When commissioning air diffusers and the duct systems for the GOLD, it is appropriate to follow the proportionality method.

This means that the ratio between the airflows in branch ducts remains constant even if you change the airflow in the main ducts. The same ratio applies to the air diffusers in the installation.

When commissioning the duct system there is provision for locking the speed of the fans in the AHU to provide a specific preset flow rate, see Section 4.1.7 in the Function Manual, Installation.

3.2.1 Adjustment Sequence

The system should be adjusted in the following order:

1. Adjust of the air diffusers in each branch duct.
2. Adjust the branch ducts.
3. Adjust the main ducts.

3.2.2 Commissioning procedure

1. Set all the air diffusers and dampers to the fully open position.
2. Calculate the quotient between the airflow reading and the design airflow of all the air diffusers, branch ducts and main ducts. The air diffuser in every branch that has the lowest quotient should be fully open. Use this air diffuser as an INDEX AIR DIFFUSER. The same applies to branch dampers and main dampers.

When you've finished commissioning, one air diffuser in every branch, one branch damper and one main damper should consequently be fully open.

3. Start adjusting the main duct that has the highest quotient and the branch duct in the main duct that has the highest quotient. Starting from this point enables you to then "press" the air in front of you toward the sections of the system that have the least air.
4. Adjust the last air diffuser on the duct branch so that it will have the same quotient as the index air diffuser. This air diffuser becomes the REFERENCE AIR DIFFUSER. The last air diffuser on the branch is often the one that has the lowest quotient and this air diffuser should be open. In this case, the index air diffuser and the reference air diffuser will be one and the same.
5. Throttle the other air diffusers in the branch to the same quotient as the reference device.
NOTE! The quotient in the reference terminal will change every time another air diffuser is throttled, so in practice the quotient for the reference air diffuser can be set slightly higher. The reference device must be measured in between each air diffuser throttled.
6. Go to the branch that had the next highest quotient and adjust the air diffusers there, etc.
NOTE! All branch dampers should be fully open until all air diffusers have been adjusted.
7. Throttle the branch damper that had the highest quotient to the same quotient as the branch that had the lowest quotient.
NOTE! Keep in mind that the index damper changes quotient; proceed as described in item 5.
8. When all branches have been commissioned, throttle the main dampers in the same manner.

See also Adjustment example below.

Example on how to make an adjustment

– Start adjusting duct branch B, since this one has the highest quotient.

– The last air device, B3, has the lowest quotient and should be fully open.

Adjust the other air devices, B1 and B2, so that these will have the same quotient as air device B3 (see item 5 above).

– Now adjust the air devices in branch duct C. Air device C4 should be fully open; throttle the others to the same quotient.

– Adjust the air devices in branch duct A. The index air device here is air device A4 (the reference device) to device A3:s quotient. Then adjust the others to the same quotient as air device A4.

– Throttle branch damper B to the same quotient as branch damper A, throttle branch damper C to the same quotient as branch damper A.

Check that all dampers have the same quotient. When commissioning has been completed, 3 air devices and one branch damper should stand fully open to obtain the lowest possible pressure in the system.

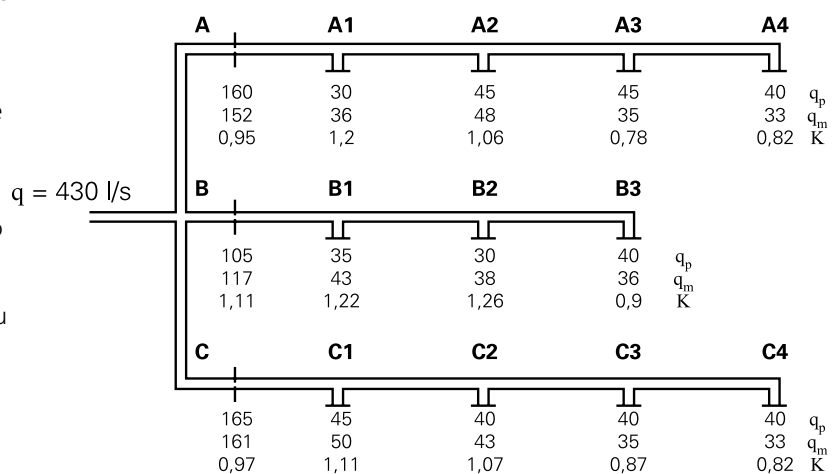

qp = design airflow (l/s)

qm = flow reading (l/s)

$$K \text{ (Quotient)} = \frac{qm}{qp}$$

3.3 To Adjust the Pressure Balance

3.3.1 General

There should be a certain degree of negative pressure in the extract air section so that the direction of air leakage through the heat exchanger and the function of the purging sector will be correct. This ensures that extract air will not be transferred to the supply air.

The pressure balance in the unit should be adjusted when the ventilation system has been fully installed and the airflows discharged from all the air diffusers and registers have been adjusted, and when the supply air and extract airflows are as they should be while the air handling unit is operating normally.

Commissioning plates

GOLD RX

Air intake viewed from the side

Sizes 004 – 012, 1 – 2 plates

Sizes 014 – 120, 1 – 5 plates

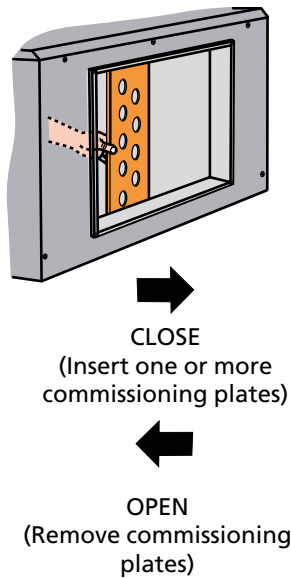
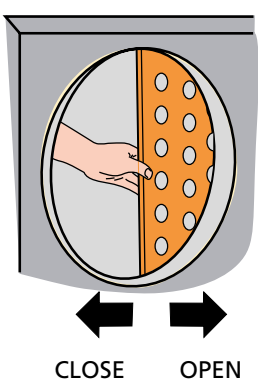

Air intake viewed from above

Sizes 014 – 030, 2 plates

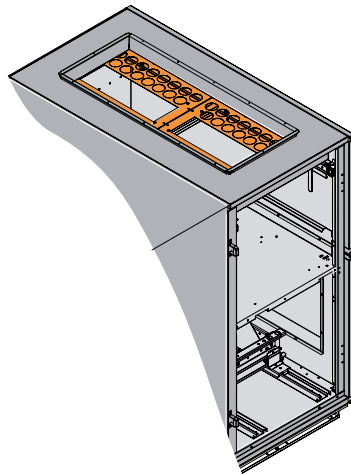

Secure the commissioning plates to the ceiling with self-tapping screws from inside the AHU.

Adjust the pressure balance by blanking off the holes in the commissioning plate using the plastic plugs supplied with it (reach up and insert plastic plug through the rectangular hole in the commissioning plate).

Adjust the pressure balance by blanking off the holes in the commissioning plate using the supplied plastic plugs.

GOLD RX Top 004-008
Supply air fan lower level, 1 plate

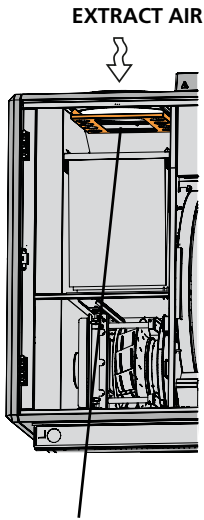

Commissioning plate

Supply air fan upper level, 2 plates

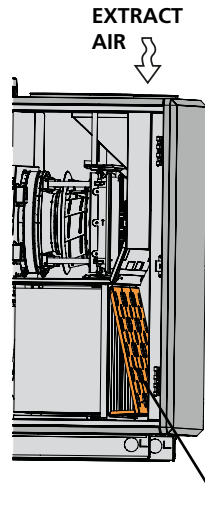

Commissioning plate
Hook the commissioning plates on the upper filter guide, now press the commissioning plates downwards so that they hook into the lower guide.

GOLD RX Top 011/012,
Supply air fan, lower level, 1 plate

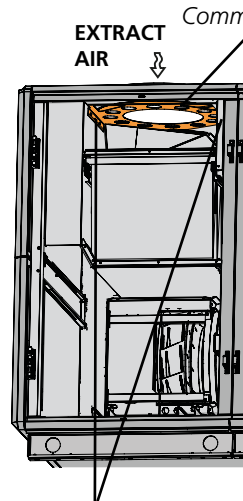

Mounting screws (3 in total)

Supply air fan, upper level, 1 plate

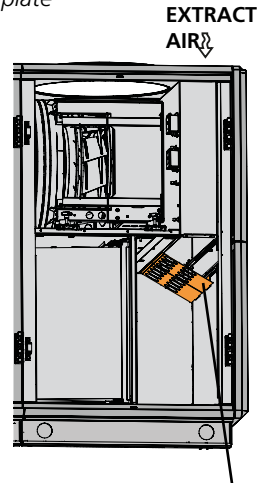

Commissioning plate
Hook the commissioning plate in the groove in the side against the filter. Raise the commissioning plate towards the AHU casing and hook in the groove.

Remove the mounting screw(s) where applicable and place the commissioning plate in the intended slots. Tighten the mounting screw(s). See the illustration above. Adjust the pressure balance by blanking off the holes in the commissioning plate using the supplied plastic plugs.

Supplied commissioning plate for GOLD RX Top 004-012. If air directions are changed, another commissioning plate must be ordered.

GOLD RX Top 014-030
Supply air fan lower level, 3 plates

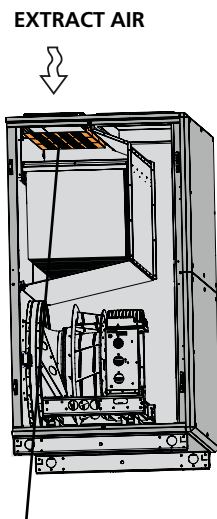

Commissioning plates
Snap the commissioning plates into place around the ferrule in the roof.

GOLD RX Top 014-030
Supply air fan upper level, 3 plates

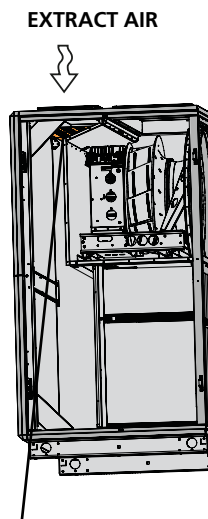

Commissioning plates
Snap the commissioning plates into place around the ferrule in the roof.

Adjust the pressure balance by blanking off the holes in the commissioning plate using the supplied plastic plugs.

3.3.2. Ensure correct direction of air leakage

The commissioning plates fitted in the extract air inlet are used for adjusting the pressure balance in the unit. The commissioning plates are supplied separately and should be installed by the fitter when the extract air duct is connected. See the illustrations on the following pages.

Connect a pressure gauge to the pressure measurement tappings of the air handling unit. The unit has four pressure measurement tappings. The two tappings closest to the extract air duct should be used. The blue pressure measurement tapping is used for measuring the negative pressure in the extract air section and the white pressure measurement tapping is used for measuring the negative pressure in the supply air section.

On the size 004-008 units (common casing), the pressure measurement tappings are in the electrical equipment cubicle/ electrical distribution box and on the size 004-120 units (split version) they are inside in the centre section of the unit. When you combine the GOLD RX Top 004-012 with the COOL DX Top, note that the pressure measurement tappings are located inside the centre section of the air handling unit. See illustration to the right.

Note that both pressure measurement tappings are used for measuring negative pressure.

MEASURED VALUES

The negative pressure in the extract air section should be higher or the same as the negative pressure in the supply air section.

If the negative pressure in the extract air section is the same or up to 20 Pa greater than the negative pressure in the supply air section, when you've finished this adjustment.

Deviations

If the negative pressure in the extract air section is less than that in the supply air section, the damper setting must be adjusted as follows:

1. Stop the air handling unit, open the inspection door to access the extract air filter.
 GOLD RX Top/GOLD RX with air intake from above: Blank off the appropriate number of holes in the commissioning plate using the plastic plugs supplied.
 GOLD RX with air intake from the side: Push the commissioning plates in the extract air intake slightly forward (to close them).
 For full face connection (duct accessory in insulated casing): If the commissioning plate(s) is/are completely closed and the sub-atmospheric pressure in the extract air section is still less than in the supply air section, blank off an appropriate number of holes in the commissioning plate using the plastic plugs supplied.
3. Close the inspection door and restart the unit.
4. Measure the pressures.
 Repeat this procedure until the negative pressure in the extract air section is just as high or up to 20 Pa higher than the negative pressure in the supply air section (0–20 Pa).
5. If the negative pressure in the extract air section is higher than 20 Pa compared with the supply air section, although the commissioning plates are completely open, the leakage and purging air flow will be more than necessary, and this will cause the extract air fan to consume more power.

Pressure measurement tappings – leakage direction (Unit shown in the right-hand version)

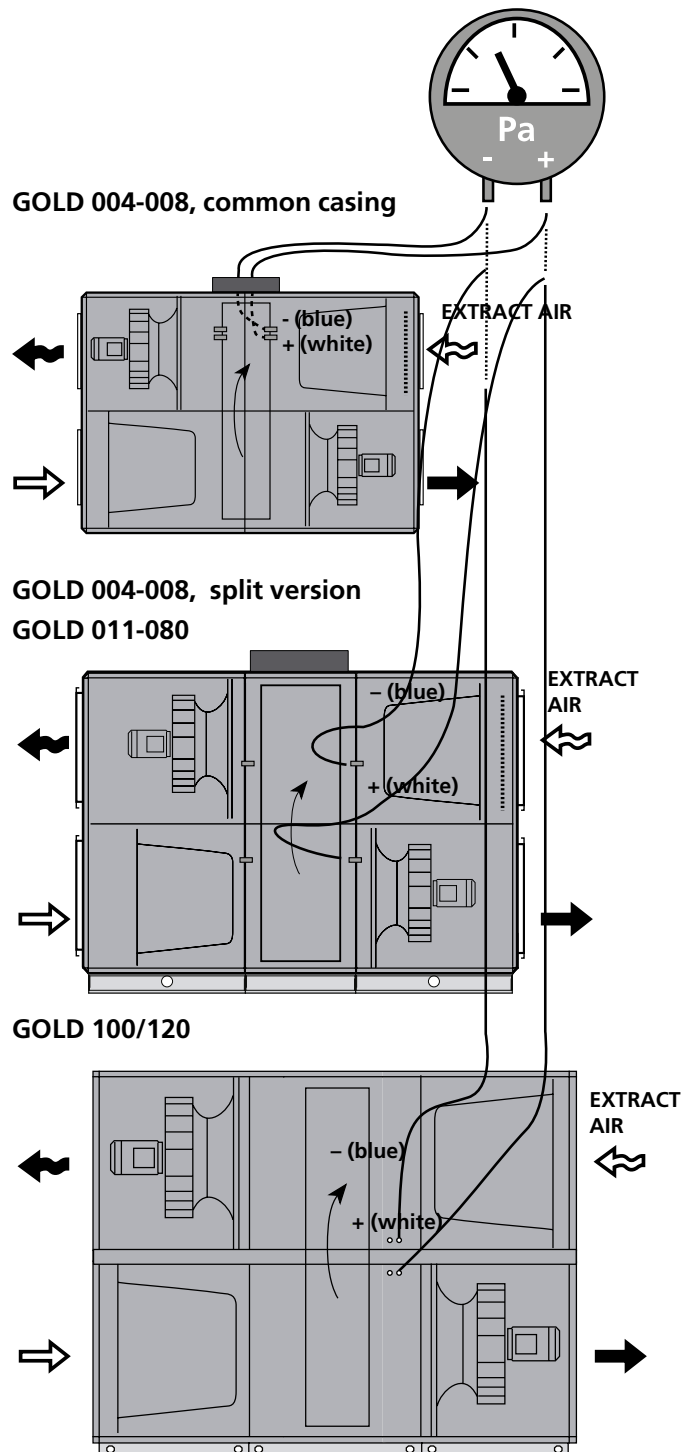

4. Maintenance



Warning

Before carrying out any work, make sure that the power supply to the air handling unit has been switched off.

4.1 Filter change

Filters made of glass fibre should be replaced, and if a pre-filter made of woven aluminium is fitted, it should be washed, when the corresponding filter alarm has been activated.

Order new filters from Swegon or your nearest Swegon representative. Specify the size of the GOLD unit, whether the replacement concerns one or two directions of airflow and if you are replacing standard filters and/or possibly a pre-filter.

4.1.1 Dismantling the filters

It is advisable to clean inside the filter space while the filters are removed.

Standard filters:

Pull out the handles (A) to free the filters from the filter holder. Withdraw the filters.

Possible pre-filters inside the air handling unit:

Withdraw the filters.

4.1.2 Installing new filters

Standard filters:

Insert the filters into the filter holder. At the same time, draw out the filter bags, if installed, so that they will not become caught, damaged or folded.

Insert the filters as far as possible into the unit and press them lightly against the filter frames, so that they fit tightly.

Push in the handles (A) to clamp the filters in position in the filter holder.

Close the inspection doors.

Finish with filter calibration according to Section 2 in the Function Manual, Users.

Pre-filters, if installed, in the AHU:

Insert the filters in the filter guide rails as far as possible into the AHU and press them lightly against the filter frames, so that they fit tightly.

Finish with filter calibration according to Section 2 in the Function Manual, Users.

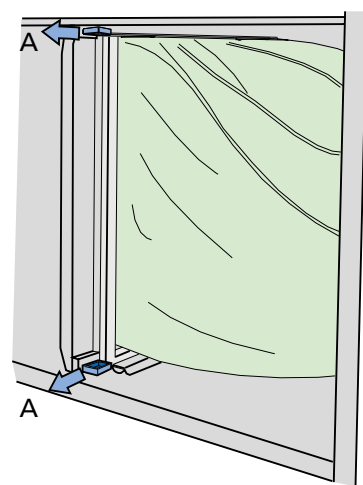

4.2 Cleaning and Inspection

4.2.1 General

Access for cleaning must be ensured when planning and during the installation of the air handling unit. This can, for example, include the set-up of the unit, and pipe and cable routing.

Clean the interior of the air handling unit if needed. Inspection of the air handling unit should be performed when you change filters or at least twice a year.

4.2.2 Filter spaces

The most appropriate time to clean the unit is when you change the filters.

4.2.3 Heat exchangers

Check whether cleaning is necessary at least twice a year. Cleaning can be done from the filter space.

The heat exchanger should above all be cleaned by vacuum cleaning with a soft nozzle to prevent damage to the air passages in the rotor.

Turn the rotor by hand to reach all surfaces. If the heat exchanger is substantially fouled, its surfaces can be blown clean with compressed air.

If needed, the heat exchanger can be withdrawn from the unit casing and washed with degreasing solvent. Only service personnel trained by Swegon shall be permitted to wash it in this way.

Vinyl-coated fabric seal

Lift up the fabric seal and inspect its underside. Clean if needed by brushing or vacuum cleaning.

If the fabric seal is worn or substantially fouled, it should be replaced. Do not lubricate it!

Drive belt tension

Replace the drive belt if it feels loose or worn and slightly slips if it meets resistance. Contact service personnel trained by Swegon.

4.2.4 Fans and fan spaces

Inspect and, if needed, clean the fan impellers to remove dirt deposits.

Check the impeller to make sure that it is not out of balance.

Check the bearings for noise.

Vacuum clean the fan motor or brush its surfaces. It can also be cleaned by carefully wiping it with a damp cloth and dishwashing detergent.

Clean the fan space, if needed.

4.3 Service and Functionality Check

Service and functionality inspections shall be carried out at the interval specified below.

Item to check	Action	6-monthly service	12-monthly service
Service			
Filters	To be replaced when the display screen indicates a filter alarm. Check that the filter installation frame is in working order and is tight.		x
Fans, heat exchangers, duct accessories	Inspect and clean if necessary.	x	
Internal surfaces	Inspect and clean if necessary.	x	
External surfaces	Inspect and clean if necessary.		x
Gaskets, sealing strips, bearings, drive belts	Inspect and remedy if necessary.		x
Sensors, cabling, measuring tubes	Carry out visual inspection and remedy if necessary.		x
Functionality inspection			
Safety functions, fire and frost protection, etc.	To inspect the functionality.		x
Other control functions	To inspect the functionality. Compare the air handling unit's values with the commissioning report. Remedial measures should be taken to correct any possible inconsistencies.		x
Alarm history	Review.	x	

4.4 Warranty

To submit a warranty claim, you must be able to produce a complete documented and signed Service and Functionality Inspection Report of the product with hits accessories.

A Service and Functionality Inspection Report must be performed according to the instructions in Sections 4.1, 4.2 and 4.3.

General conditions for warranty liability are given in the delivery provisions applicable to the supply.

5. Alarms and Troubleshooting

5.1 General

Alarms are displayed by a flashing red LED in the hand-held terminal.

When the LED flashes, go in under Alarm log in the instrument panel, see Section 2.2.3 in the Operating Procedures Manual of the IQnavigator hand-held micro terminal.

Active alarms, pending alarms and alarm history (50 latest) can be viewed under Alarm log.

For resetting alarms, you can select individual alarms or all the alarms.

The reset time can also be viewed under History.

A fault can be traced by examining the function or functional component indicated in the alarm text.

If the fault cannot be immediately remedied:

Consider whether the air handling unit can continue to operate until the fault has been remedied. Choose to block the alarm and/or to change it from stop to operation. See Section 4.8.6 in the Function Manual, Installation.

5.1.1 A and B Alarms

A alarms send an indication to the output for alarm relay A (IQlogic module*).

B alarms send an indication to the output for alarm relay B (IQlogic module*).

Alarms can be forwarded with different priority via these relays.

5.1.2 To Reset Alarms

Alarms with manual resetting can be reset from the hand-held terminal. Select reset in the alarm log.

Alarms that reset themselves automatically will do so as soon as the fault has been remedied.

Alarms can also be reset via a communication network (not applicable to frost guard alarm).

5.1.3 To Change Alarm Priority

See Section 4.8.6 in the Function Manual, Installation.

6. Technical data

6.1 Dimensions

6.1.1 GOLD RX (not Top)

GOLD 004/005, common casing

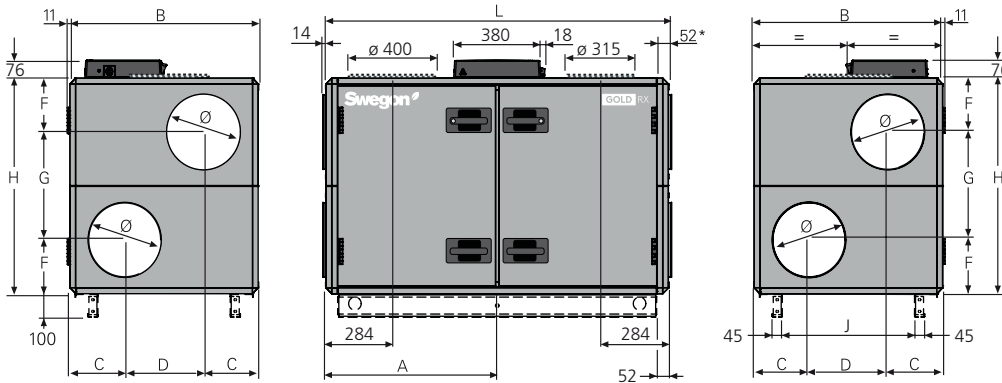

* The air handling unit is supplied without end connection panel if a duct accessory housed in an insulated casing will be connected. The AHU can also be supplied with full face end connection panel (accessory).

Base beams are optional.

GOLD 007/008, common casing

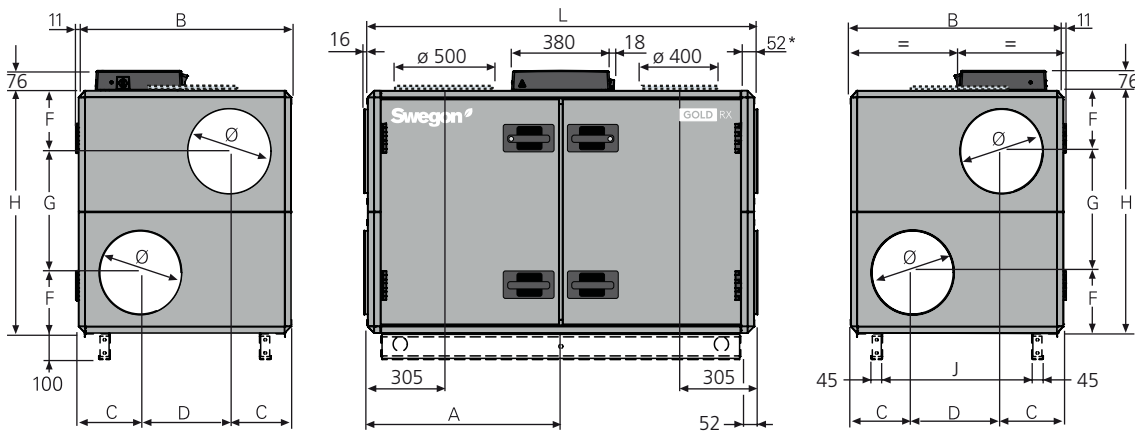

* The air handling unit is supplied without end connection panel if a duct accessory housed in an insulated casing will be connected. The AHU can also be supplied with full face end connection panel (accessory).

Base beams are optional.

Size	A	B	C	D	F	G	H	J	K	L	Ø	Weight, kg
004/005	743	825	240	345	230	460	920	579	–	1499	315	234-278
007	805	995	277,5	440	271	543	1085	749	–	1619	400	281-355
008	805	995	277,5	440	271	543	1085	749	–	1619	400	295-363

GOLD 004/005, split version

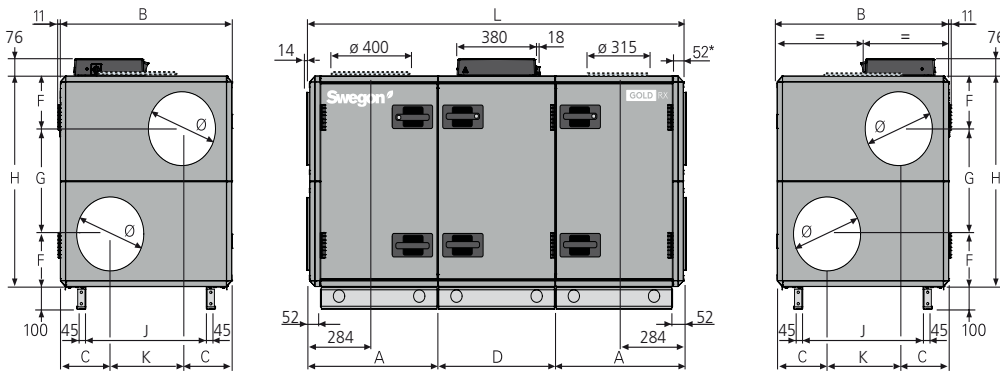

* The air handling unit is supplied without end connection panel if a duct accessory housed in an insulated casing will be connected. The AHU can also be supplied with full face end connection panel (accessory).

GOLD 007/008, split version

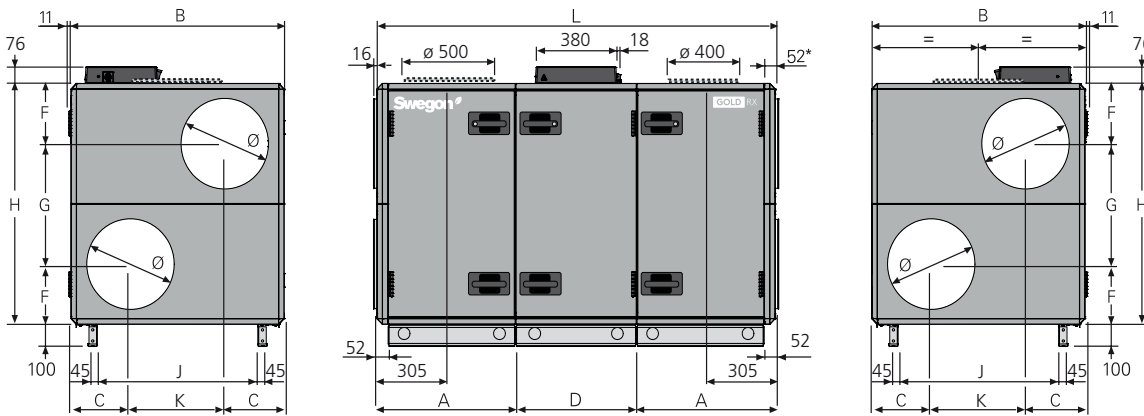

* The air handling unit is supplied without end connection panel if a duct accessory housed in an insulated casing will be connected. The AHU can also be supplied with full face end connection panel (accessory).

Size	A	B	C	D	F	G	H	J	K	L	Ø	Weight, kg
004/005	617	825	240	565	230	460	920	579	345	1799	315	278-335
007	647,5	995	277,5	565	271	543	1085	749	440	1860	400	327-412
008	647,5	995	277,5	565	271	543	1085	749	440	1860	400	341-420

GOLD 011/012

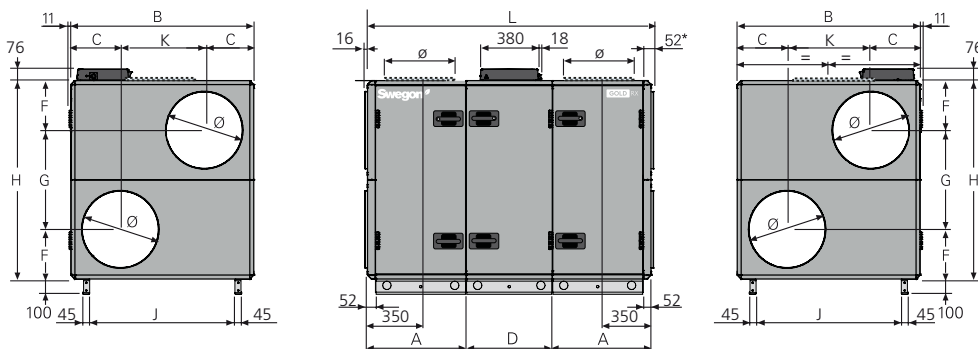

* The air handling unit is supplied without end connection panel if a duct accessory housed in an insulated casing will be connected. The AHU can also be supplied with full face end connection panel (accessory).

Size	A	B	C	D	F	G	H	J	K	L	Ø	Weight, kg
011	647	1199	324	565	324	647	1295	953	551	1859	500	427-527
012	647	1199	324	565	324	647	1295	953	551	1859	500	450-554

GOLD 014/020

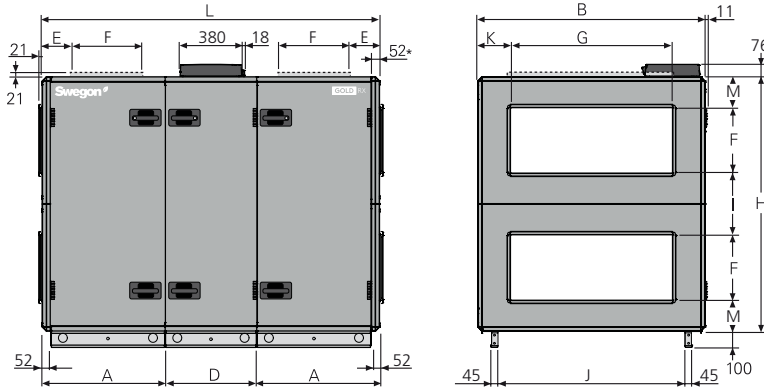

* The air handling unit is supplied without end connection panel if a duct accessory housed in an insulated casing will be connected. The AHU can also be supplied with full face end connection panel (accessory).

GOLD 025/030

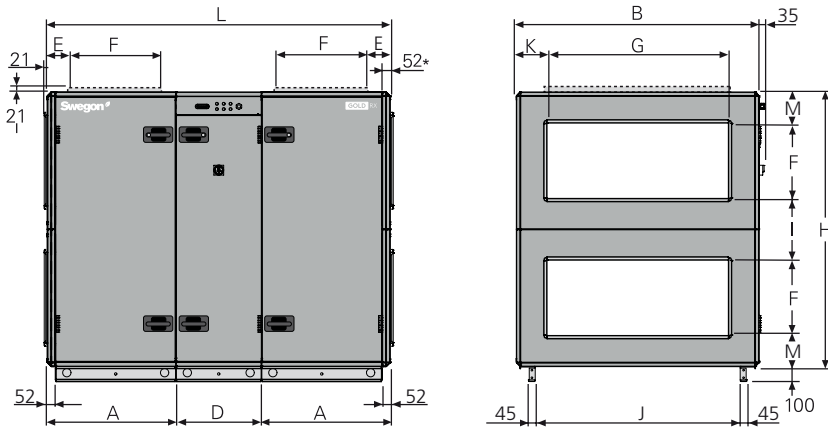

* The air handling unit is supplied without end connection panel if a duct accessory housed in an insulated casing will be connected. The AHU can also be supplied with full face end connection panel (accessory).

GOLD 035/040

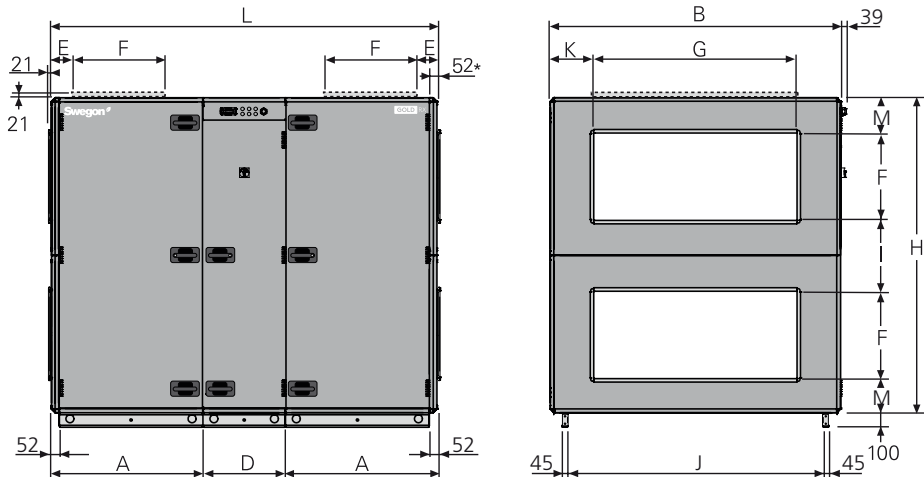

* The air handling unit is supplied without end connection panel if a duct accessory housed in an insulated casing will be connected. The AHU can also be supplied with full face end connection panel (accessory).

Size	A	B	D	E	F	G	H	I	J	K	L	M	Weight, kg
014/020	757,5	1400	565	205	400	1000	1551	375	1154	200	2080	188	572-746
025/030	848	1600	565	200	500	1200	1811	405	1354	200	2261	203	744-971
035/040	1038,5	1990	565	245	600	1400	2159	479	1744	295	2642	240	1096-1405

GOLD 014+/020+

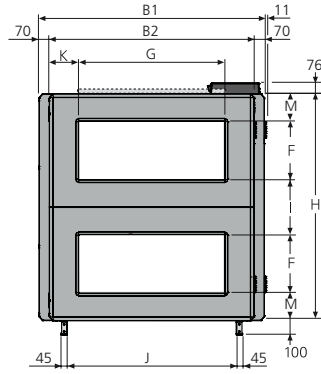
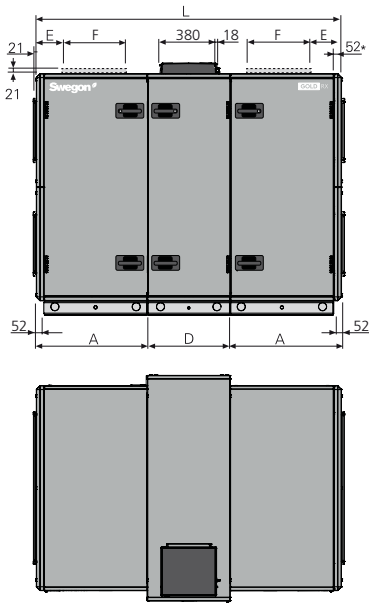

* The air handling unit is supplied without end connection panel if a duct accessory housed in an insulated casing will be connected. The AHU can also be supplied with full face end connection panel (accessory)

Size	A	B1	B2	D	E	F	G	H	I	J	K	L	M	Weight, kg
014+/020+	757,5	1540	1400	565	205	400	1000	1551	375	1154	200	2080	188	612-799

GOLD 025+/030+

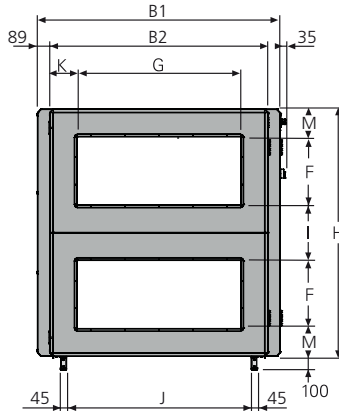
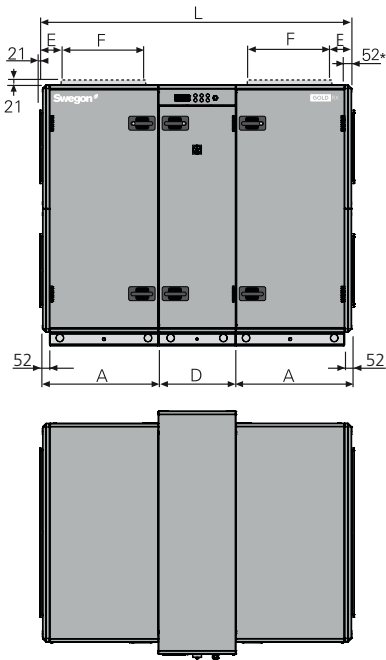

* The air handling unit is supplied without end connection panel if a duct accessory housed in an insulated casing will be connected. The AHU can also be supplied with full face end connection panel (accessory)

Size	A	B1	B2	D	E	F	G	H	I	J	K	L	M	Weight, kg
025+/030+	848	1777	1600	565	200	500	1200	1811	405	1354	200	2261	203	793-1036

GOLD 050/060

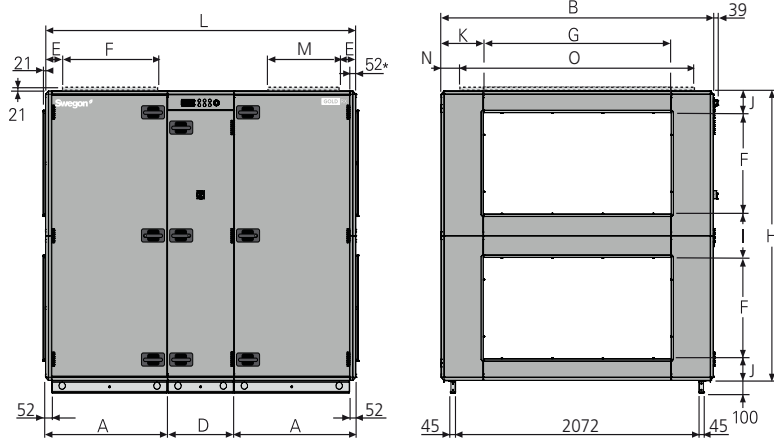

* The air handling unit is supplied without end connection panel if a duct accessory housed in an insulated casing will be connected. The AHU can also be supplied with full face end connection panel (accessory).

GOLD 070/080

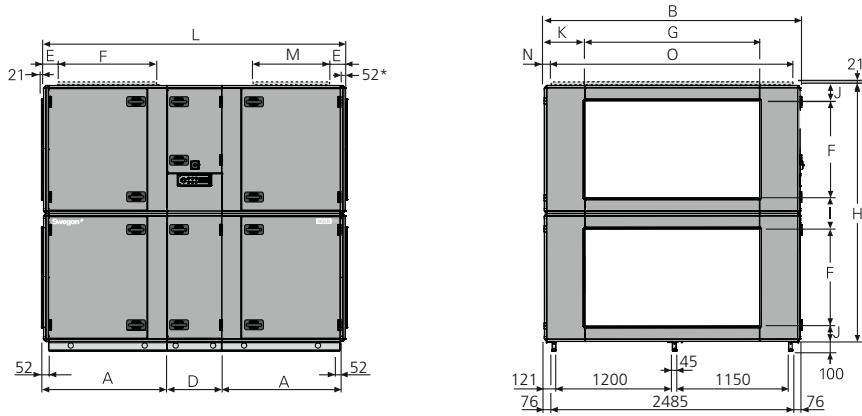

* The air handling unit is supplied without end connection panel if a duct accessory housed in an insulated casing will be connected. The AHU can also be supplied with full face end connection panel (accessory).

Size	A	B	D	E	F	G	H	I	J	K	L	M	N	O	Weight, kg
050/060	1038,5	2318	565	145	800	1600	2288	344	172	359	2642	600	159	2000	1298-1752
070/080	1273,5	2637	565	162	1000	1800	2640	320	160	418,5	3112	750	118,5	2400	2218-2649

GOLD 070+/080+

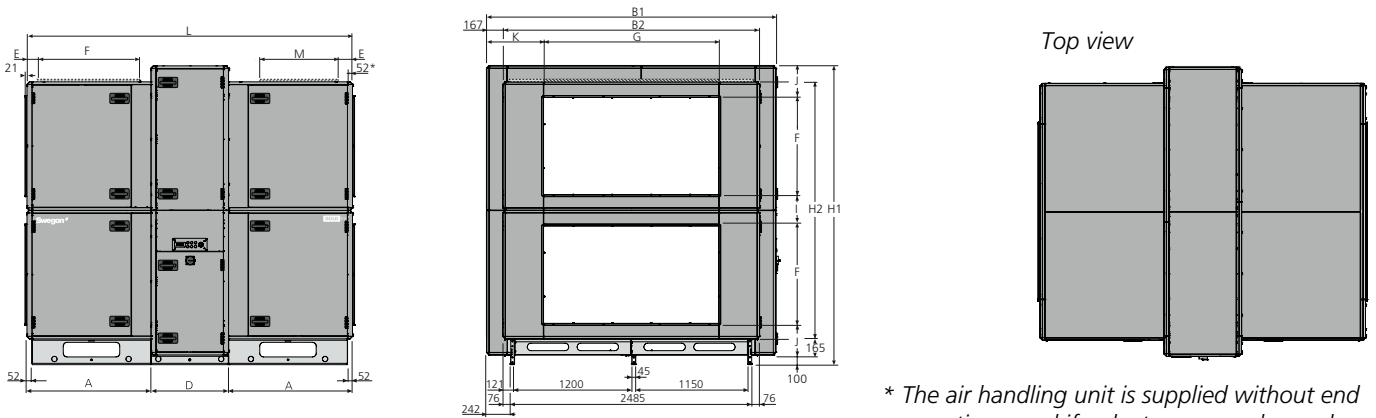

Size	A	B1	B2	D	E	F	G	H1	H2	I	J	K	L	M	Weight, kg
070+/080+	1273,5	2970	2637	796	162	1000	1800	3070	2640	320	325	585	3343	750	2614-3335

GOLD 100/120

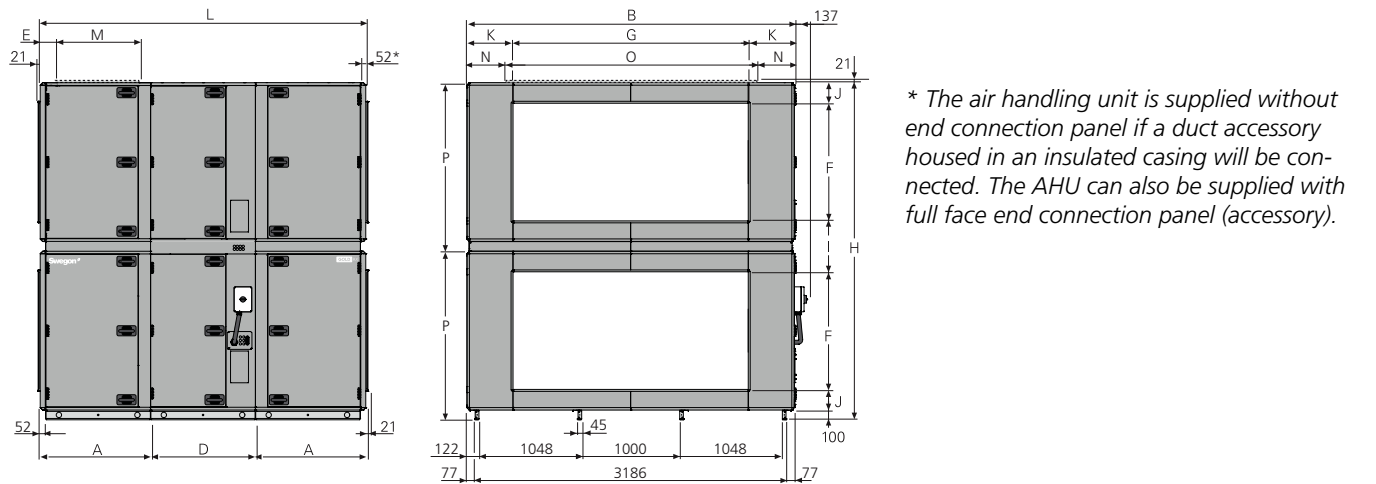

Size	A	B	D	E	F	G	H	I	J	K	L	M	N	O	P	Weight, kg
100	1122	3340	1070	187	1200	2400	3440	520	210	470	3314	800	420	2500	1720	3324-3910
120	1122	3340	1070	187	1200	2400	3440	520	210	470	3314	800	420	2500	1720	3524-4128

6.1.2 GOLD RX Top

GOLD RX Top 004/005

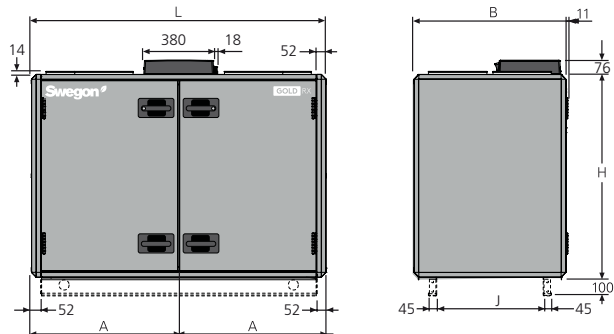

GOLD RX Top 007/008

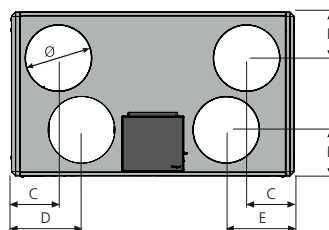
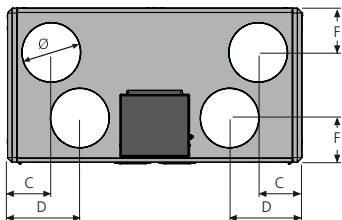
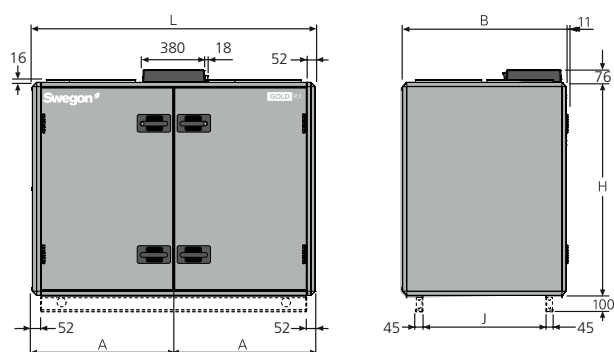

Size	A	B	C	D	E	F	H	J	L	Ø	Weight, kg
Top 004	800	825	238	393	-	237	1085	579	1600	315	295-302
Top 005	800	825	238	393	-	237	1085	579	1600	315	295-310
Top 007	860	995	286	426	406	280	1295	749	1720	400	351-376
Top 008	860	995	286	426	406	280	1295	749	1720	400	369-382

GOLD RX Top 011/012

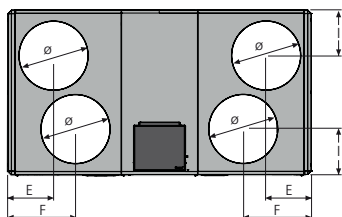
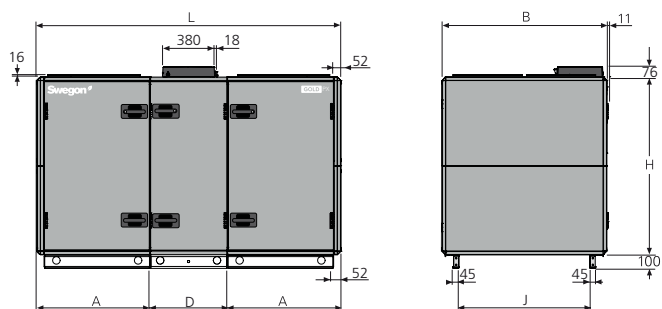

Size	A	B	C	D	E	F	G	H	I	J	K	L	Ø	Weight, kg
Top 011	827	1199	-	565	332	500	-	1295	332	953	-	2219	500	527-549
Top 012	827	1199	-	565	332	500	-	1295	332	953	-	2219	500	550-576

GOLD RX Top 014/020

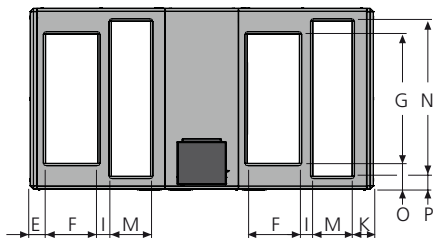
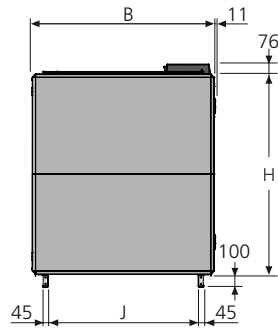
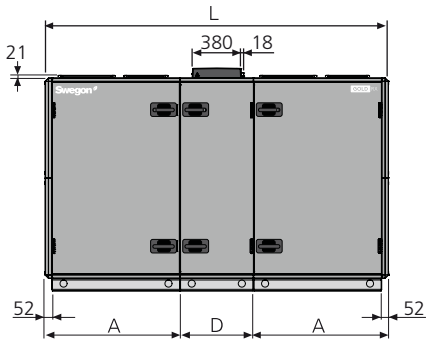

View from above. Shows the air handling unit's duct connections for supply air fan right up and left down

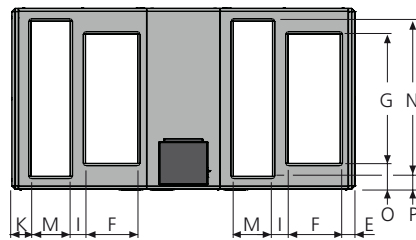

View from above. Shows the air handling unit's duct connections for supply air fan right down and left up

Size	A	B	D	E	F	G	H	I	J	K	L	M	N	O	P	Weight, kg
014/020	1039	1400	565	120	400	1000	1551	106	1154	165	2643	300	1200	200	100	726-832

GOLD RX Top 014+/020+

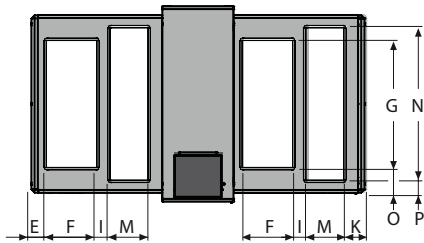
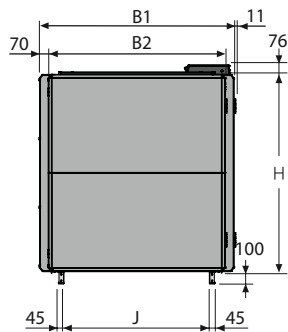
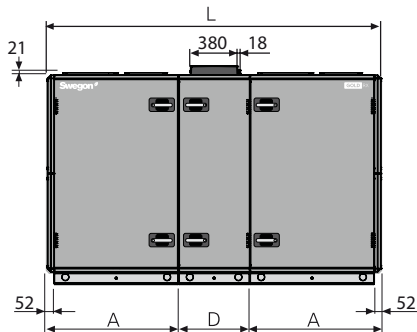

View from above. Shows the air handling unit's duct connections for supply air fan right up and left down

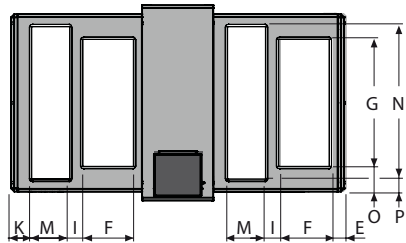

View from above. Shows the air handling unit's duct connections for supply air fan right down and left up

Size	A	B1	B2	D	E	F	G	H	I	J	K	L	M	N	O	P	Weight, kg
014+/020+	1039	1540	1400	565	120	400	1000	1551	106	1154	165	2643	300	1200	200	100	766-885

GOLD RX Top 025/030

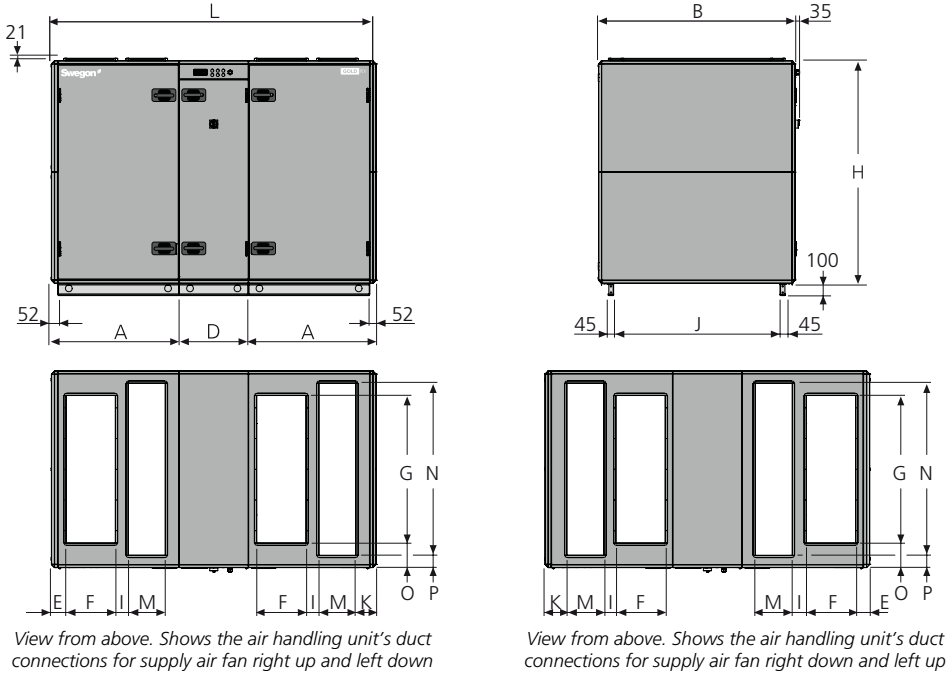

Size	A	B	D	E	F	G	H	I	J	K	L	M	N	O	P	Weight, kg
025/030	1039	1600	565	120	400	1200	1811	106	1354	165	2643	300	1400	200	100	884-1033

GOLD RX Top 025+/030+

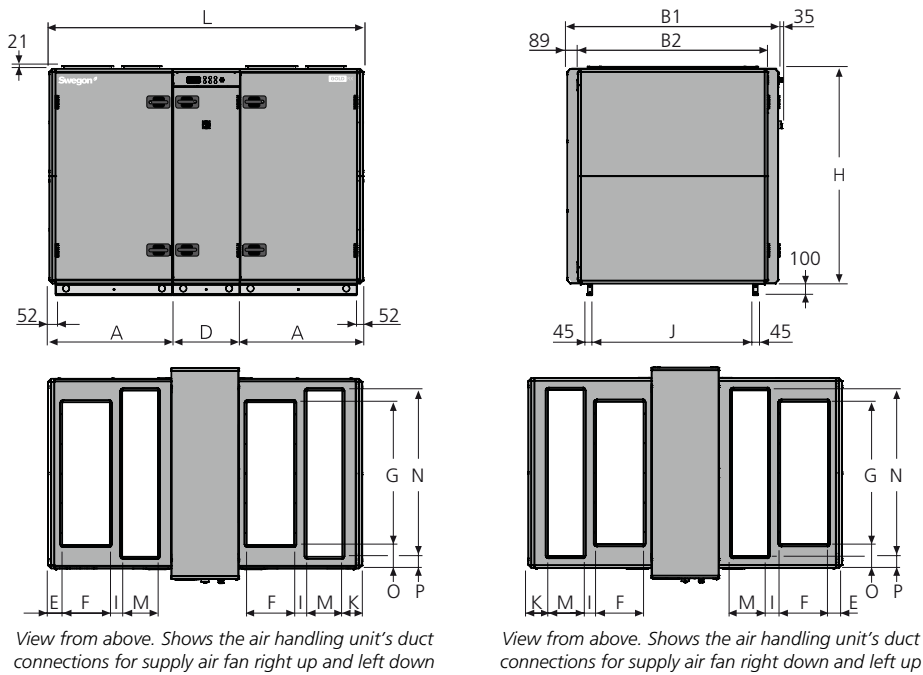

Size	A	B1	B2	D	E	F	G	H	I	J	K	L	M	N	O	P	Weight, kg
025+/030+	1039	1777	1600	565	120	400	1200	1811	106	1354	165	2643	300	1400	200	100	933-1098

6.2 Connection to Wiring Terminals

The max. permissible load on the corresponding connection is 16 VA.

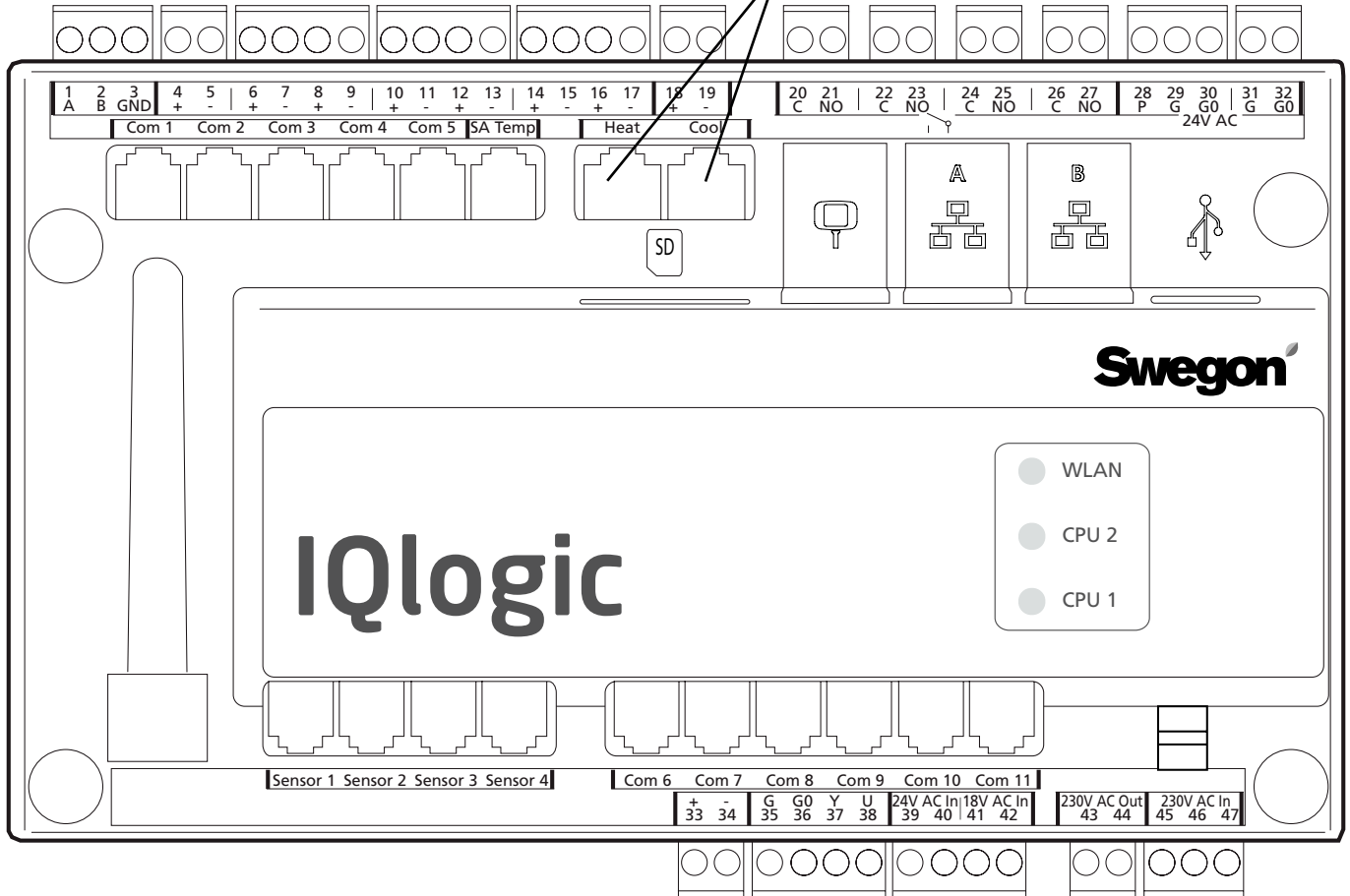

Digital inputs, terminals 4-17, are of extra-low voltage type. Analogue input, terminals 18-19 have an input impedance of 66 kΩ. 230 VAC control voltage is on external terminals 101 (L) and 102 (N).

Wiring terminal	Function	Remarks
1,2,3	Connections for EIA -485	1= Communication connection A/RT+, 2= Communication connection B/RT-, 3= GND/COM.
4,5	External stop	Stops the unit by opening the circuit. On delivery, this function is fitted with a jumper. If the connection is interrupted, the unit will stop.
6,7	External fire/smoke function 1	External fire and smoke function. On delivery, this function is fitted with a jumper. If the connection is interrupted, the function will trip and initiate an alarm.
8,9	External fire/smoke function 2	External fire and smoke function. On delivery, this function is fitted with a jumper. If the connection is interrupted, the function will trip and initiate an alarm.
10,11	External alarm 1	External contact function. Optional: Normally open/normally closed.
12,13	External alarm 2	External contact function. Optional: Normally open/normally closed.
14,15	External low speed	External contact function. Oversteers the timer from stop to low speed operation.
16,17	External high speed	External contact function. Oversteers the timer from stop or low speed to high speed operation.
18,19	Demand control	Input for 0-10 V DC. The input signal influences the supply air/extract airflow set point if the unit is operating in the demand control mode. For connection of sensors, for example CO ₂ , CO and VOC
20,21	Circulation pump, heating circuit	Independent contact, max. 5 A/AC1, 2 A/AC3, 250 VAC. Closes on a heating load.
22,23	Circulation pump, cooling circuit or cooling on/off, 1-step operation	Independent contact, max. 5 A/AC1, 2 A/AC3, 250 VAC. Closes on a cooling load.
24,25	Cooling, on/off, 2-step operation	Independent contact, max. 5 A/AC1, 2 A/AC3, 250 VAC. Closes on a cooling load.
26,27	In-operation indication	Independent contact, max. 5 A/AC1, 2 A/AC3, 250 VAC. Closes when the unit is operating.
28,29,30	Damper control	24 VAC. 28= Controlled 24 VAC (G), 29= 24 VAC (G), 30= 24 VAC (GO).
31,32	Control voltage ¹⁾	24 VAC control voltage. Terminals 31-32 are loaded with a total of 16 VA. Opened by means of the safety isolating switch.
33,34	Reference voltage	Output for constant 10 VDC. Max. permissible load: 8 mA.
35,36,37,38	Control, recirculation damper	The recirculation damper can be loaded with max. 2 mA at 10 VDC. 35= 24 V AC (G), 36= 24 V AC (GO), 37= 0-10 V DC control signal, 38= 0-10 VDC feedback signal.

The max permissible common load on terminals 31-32, outputs for Heat/Cool and damper output (terminals 28-30) is max 32 VA (SD) eller 50 VA (RX/IPX/CX).

¹⁾ GOLD 100/120: If more than 16 VA is required, use wiring terminals 201 (G) and 202 (GO). Terminals 201-202 can be loaded with a total of max, 48 VA.

6.3 Electrical Data

6.3.1 Air Handling Units

6.3.1.1 Size 004-012

MIN. POWER SUPPLY

GOLD 004:

1-phase, 3-wire, 230 V -10/+15%, 50 Hz, 10 AT *or*

3-phase, 5-wire, 400 V -10/+15%, 50 Hz, 10 AT

GOLD 005, capacity variant 1:

1-phase, 3-wire, 230 V -10/+15%, 50 Hz, 10 AT *or*

3-phase, 5-wire, 400 V -10/+15%, 50 Hz, 10 AT

GOLD 005, capacity variant 2:

1-phase, 3-wire, 230 V -10/+15%, 50 Hz, 16 AT *or*

3-phase, 5-wire, 400 V -10/+15%, 50 Hz, 10 AT

GOLD 007, capacity variant 1:

1-phase, 3-wire, 230 V -10/+15%, 50 Hz, 10 AT *or*

3-phase, 5-wire, 400 V -10/+15%, 50 Hz, 10 AT

GOLD 007, capacity variant 2:

1-phase, 3-wire, 230 V -10/+15%, 50 Hz, 16 AT *or*

3-phase, 5-wire, 400 V -10/+15%, 50 Hz, 10 AT

GOLD 008, capacity variant 1:

1-phase, 3-wire, 230 V -10/+15%, 50 Hz, 16 AT *or*

3-phase, 5-wire, 400 V -10/+15%, 50 Hz, 10 AT

GOLD 008, capacity variant 2:

3-phase, 5-wire, 400 V -10/+15%, 50 Hz, 10 AT

GOLD 011, capacity variant 1:

1-phase, 3-wire, 230 V -10/+15%, 50 Hz, 16 AT *or*

3-phase, 5-wire, 400 V -10/+15%, 50 Hz, 10 AT

GOLD 011, capacity variant 2:

3-phase, 5-wire, 400 V -10/+15%, 50 Hz, 10 AT

GOLD 012, capacity variant 1 and 2:

3-phase, 5-wire, 400 V -10/+15%, 50 Hz, 10 AT

6.3.1.2 Size 014-120

Shows the fuse size for different combinations of fan sizes and capacity variants. Fan A or B can be a supply air fan or an extract air fan or vice versa. It is the combination of fan A and B that determines the fuse size.

The air handling unit's rating plate shows the combinations of fan sizes and capacity variants.

Electrical connection is 3-phase, 5-wire, 400 V -10/+15%, 50 Hz.

GOLD RX, size	Fan A, size/capacity variant	Fan B, size/capacity variant	Fuse protection (A)
014/020 014+/020+	014-1 (1,6 kW)	014-1 (1,6 kW)	10
	014-1 (1,6 kW)	014-2 (2,4 kW)	10
	014-1 (1,6 kW)	020-1 (2,4 kW)	10
	014-1 (1,6 kW)	020-2 (3,4 kW)	16
	014-2 (2,4 kW)	014-2 (2,4 kW)	10
	014-2 (2,4 kW)	020-1 (2,4 kW)	10
	014-2 (2,4 kW)	020-2 (3,4 kW)	16
	020-1 (2,4 kW)	020-1 (2,4 kW)	10
	020-1 (2,4 kW)	020-2 (3,4 kW)	16
	020-2 (3,4 kW)	020-2 (3,4 kW)	16
025/030 025+/030+	025-1 (2,4 kW)	025-1 (2,4 kW)	10
	025-1 (2,4 kW)	025-2 (3,4 kW)	16
	025-1 (2,4 kW)	030-1 (4,0 kW)	16
	025-1 (2,4 kW)	030-2 (5,0 kW)	16
	025-2 (3,4 kW)	025-2 (3,4 kW)	16
	025-2 (3,4 kW)	030-1 (4,0 kW)	16
	025-2 (3,4 kW)	030-2 (5,0 kW)	20
	030-1 (4,0 kW)	030-1 (4,0 kW)	20
	030-1 (4,0 kW)	030-2 (5,0 kW)	20
	030-2 (5,0 kW)	030-2 (5,0 kW)	20
035/040	35-1 (4,0 kW)	35-1 (4,0 kW)	20
	35-1 (4,0 kW)	35-2 (5,0 kW)	20
	35-1 (4,0 kW)	40-1 (6,5 kW)	25
	35-1 (4,0 kW)	40-2 (10 kW)	25
	35-2 (5,0 kW)	35-2 (5,0 kW)	20
	35-2 (5,0 kW)	40-1 (6,5 kW)	25
	35-2 (5,0 kW)	40-2 (10 kW)	32
	40-1 (6,5 kW)	40-1 (6,5 kW)	25
	40-1 (6,5 kW)	40-2 (10 kW)	32
	40-2 (10 kW)	40-2 (10 kW)	40

GOLD RX, size	Fan A, size/capacity variant	Fan B, size/capacity variant	Fuse protection (A)
050/060	50-1 (6,5 kW)	50-1 (6,5 kW)	25
	50-1 (6,5 kW)	50-2 (10 kW)	32
	50-1 (6,5 kW)	60-1 (2 x 4,0 kW)	32
	50-1 (6,5 kW)	60-2 (2 x 6,5 kW)	40
	50-2 (10 kW)	50-2 (10 kW)	40
	50-2 (10 kW)	60-1 (2 x 4,0 kW)	40
	50-2 (10 kW)	60-2 (2 x 6,5 kW)	50
	60-1 (2 x 4,0 kW)	60-1 (2 x 4,0 kW)	32
	60-1 (2 x 4,0 kW)	60-2 (2 x 6,5 kW)	40
	60-2 (2 x 6,5 kW)	60-2 (2 x 6,5 kW)	50
070/080	70-1 (2 x 4,0 kW)	70-1 (2 x 4,0 kW)	32
	70-1 (2 x 4,0 kW)	70-2 (2 x 6,5 kW)	40
	70-1 (2 x 4,0 kW)	80-1 (2 x 6,5 kW)	40
	70-1 (2 x 4,0 kW)	80-2 (2 x 10 kW)	50
	70-2 (2 x 6,5 kW)	70-2 (2 x 6,5 kW)	50
	70-2 (2 x 6,5 kW)	80-1 (2 x 6,5 kW)	50
	70-2 (2 x 6,5 kW)	80-2 (2 x 10 kW)	63
	80-1 (2 x 6,5 kW)	80-1 (2 x 6,5 kW)	50
	80-1 (2 x 6,5 kW)	80-2 (2 x 10 kW)	63
	80-2 (2 x 10 kW)	80-2 (2 x 10 kW)	80
100	100-1 (2 x 6,5 kW)	100-1 (2 x 6,5 kW)	50
	100-1 (2 x 6,5 kW)	100-2 (2 x 10 kW)	63
	100-2 (2 x 10 kW)	100-2 (2 x 10 kW)	80
120	120-1 (3 x 6,5 kW)	120-1 (3 x 6,5 kW)	80
	120-1 (3 x 6,5 kW)	120-2 (3 x 10 kW)	100
	120-2 (3 x 10 kW)	120-2 (3 x 10 kW)	125

6.3.2 Fans

RATED DATA PER FAN

GOLD 004:	Motor shaft power: 1.15 kW (0.41 kW)*, motor controller: 1 x 230 V, 50 Hz
GOLD 005:	Motor shaft power: 1.15 kW (0.8 kW)*, motor controller: 1 x 230 V, 50 Hz
or	Motor shaft power: 1.15 kW, motor controller: 1 x 230 V, 50 Hz
GOLD 007:	Motor shaft power: 1.15 kW (0.8 kW)*, motor controller: 1 x 230 V, 50 Hz
or	Motor shaft power: 1.15 kW, motor controller: 1 x 230 V, 50 Hz
GOLD 008:	Motor shaft power: 1.15 kW, motor controller: 1 x 230 V, 50 Hz
or	Motor shaft power: 1.6 kW, motor controller: 3 x 400 V, 50 Hz
GOLD 011:	Motor shaft power: 1.15 kW, motor controller: 1 x 230 V, 50 Hz
or	Motor shaft power: 1.6 kW, motor controller: 3 x 400 V, 50 Hz
GOLD 012:	Motor shaft power: 2.4 kW (1.6 kW)*, motor controller: 3 x 400 V, 50 Hz
or	Motor shaft power: 2.4 kW, motor controller: 3 x 400 V, 50 Hz
GOLD 014/020:	Motor shaft power: 2.4 kW (1.6 kW)*, motor controller, 3 x 400 V, 50 Hz
or	Motor shaft power: 2.4 kW, motor controller, 3 x 400 V, 50 Hz
or	Motor shaft power: 3.4 kW, motor controller, 3 x 400 V, 50 Hz
GOLD 025/030:	Motor shaft power: 2.4 kW, motor controller, 3 x 400 V, 50 Hz
or	Motor shaft power: 3.4 kW, motor controller, 3 x 400 V, 50 Hz
or	Motor shaft power: 4.0 kW, motor controller, 3 x 400 V, 50 Hz
or	Motor shaft power: 5.0 kW, motor controller, 3 x 400 V, 50 Hz
GOLD 035/040:	Motor shaft power: 4.0 kW, motor controller: 3 x 400 V, 50 Hz
or	Motor shaft power: 5.0 kW, motor controller: 3 x 400 V, 50 Hz
or	Motor shaft power: 6.5 kW, motor controller: 3 x 400 V, 50 Hz
or	Motor shaft power: 10 kW, motor controller: 3 x 400 V, 50 Hz

GOLD 050/060:	Motor shaft power: 6.5 kW, motor controller: 3 x 400 V, 50 Hz
or	Motor shaft power: 10 kW, motor controller: 3 x 400 V, 50 Hz
or	Motor shaft power: 2 x 4.0 kW, motor controller: 3 x 400 V, 50 Hz
or	Motor shaft power: 2 x 6.5 kW, motor controller: 3 x 400 V, 50 Hz
GOLD 070/080:	Motor shaft power: 2 x 4.0 kW, motor controller: 3 x 400 V, 50 Hz
or	Motor shaft power: 2 x 6.5 kW, motor controller: 3 x 400 V, 50 Hz
or	Motor shaft power: 2 x 10 kW, motor controller: 3 x 400 V, 50 Hz
GOLD 100:	Motor shaft power: 2 x 6.5 kW, motor controller: 3 x 400 V, 50 Hz
or	Motor shaft power: 2 x 10 kW, motor controller: 3 x 400 V, 50 Hz
GOLD 120:	Motor shaft power: 3 x 6.5 kW, motor controller: 3 x 400 V, 50 Hz
or	Motor shaft power: 3 x 10 kW, motor controller: 3 x 400 V, 50 Hz

*) *The motor controller limits the output power to the value specified.*

6.3.3 Electrical equipment cubicle

The fuse protection of the air handling unit must not exceed the value stated in Section 6.3.1.

6.3.3.1 Size 004-012

SAFETY ISOLATING SWITCH

Capacity variant 1

GOLD RX 004-012: 20 A

Capacity variant 2

GOLD RX 005-012: 20 A

FUSES IN THE ELECTRICAL EQUIPMENT CUBICLE

Control current 230 V

1 x 2-pole MCB 1 A (power supply control card)

1 x 2-pole MCB 6 A (other control)

Fans

GOLD 004-007, GOLD 008 capacity variant 1,

GOLD 011 capacity variant 1

RX Two 2-pole, miniature circuit breakers 10A

GOLD 008 capacity variant 2, GOLD 011 capacity variant 2, GOLD 012:

RX Two 3-pole, miniature circuit breakers 10A

6.3.3.2 Size 014-120

Shows the internal fuse protection and safety isolating switch for different combinations of fan sizes and capacity variants. Fan A or B can be a supply air fan or an extract air fan or vice versa.

The air handling unit's rating plate shows the combinations of fan sizes and capacity variants.

GOLD RX, size	Fan combination		Internal fuse protection (A)		Safety isolating switch (A)
	Fan A, size/capacity variant	Fan B, size/capacity variant	Fan A	Fan B	
014/020, 014+/020+	All	All	10	10	20
025/030, 025+/030+	All	All	13	13	32
035/040	35-1	35-1	1x13	1x13	32
	35-1	35-2	1x13	1x13	32
	35-1	40-1	1x13	1x13	32
	35-1	40-2	1x13	1x16	32
	35-2	35-2	1x13	1x13	32
	35-2	40-1	1x13	1x13	32
	35-2	40-2	1x13	1x16	32
	40-1	40-1	1x13	1x13	32
	40-1	40-2	1x13	1x16	32
	40-2	40-2	1x16	1x16	63
050/060	50-1	50-1	1x13	1x13	32
	50-1	50-2	1x13	1x16	32
	50-1	60-1	1x13	2x13	63
	50-1	60-2	1x13	2x13	63
	50-2	50-2	1x16	1x16	63
	50-2	60-1	1x16	2x13	63
	50-2	60-2	1x16	2x13	63
	60-1	60-1	2x13	2x13	63
	60-1	60-2	2x13	2x13	63
	60-2	60-2	2x13	2x13	63
070/080	70-1	70-1	2x13	2x13	63
	70-1	70-2	2x13	2x13	63
	70-1	80-1	2x13	2x13	63
	70-1	80-2	2x13	2x16	63
	70-2	70-2	2x13	2x13	63
	70-2	80-1	2x13	2x13	63
	70-2	80-2	2x13	2x16	63
	80-1	80-1	2x13	2x13	63
	80-1	80-2	2x13	2x16	63
	80-2	80-2	2x16	2x16	100
100	100-1	100-1	2x13	2x13	80
	100-1	100-2	2x13	2x16	80
	100-2	100-2	2x16	2x16	80
120	120-1	120-1	3x13	3x13	80
	120-1	120-2	3x13	3x16	160
	120-2	120-2	3x16	3x16	160

FUSES IN THE ELECTRICAL EQUIPMENT CUBICLE

Control current 230 V

GOLD RX 014-050:
One 2-pole, MCB 1 A
One 2-pole, MCB 6 A

GOLD RX 060-120:
One 2-pole, MCB 1 A
One 2-pole, MCB 10 A

6.3.4 Motor in rotary heat exchanger

6.3.4.1 Rotor standard

- GOLD RX 04-08:** Step motor, 2 Nm, 55 W.
- GOLD RX 11-40:** Step motor, 4 Nm, 110 W.
- GOLD RX 50-80:** Step motor, 8 Nm, 220 W.
- GOLD RX 100-120:** Step motor. 14 Nm, 790 W.

6.3.4.2 Rotor Recosorptic

- GOLD RX 04-08:** Step motor, 2 Nm, 55 W.
- GOLD RX 11-30:** Step motor, 4 Nm, 110 W.
- GOLD RX 35-70:** Step motor, 8 Nm, 220 W.
- GOLD RX 80-120:** Step motor. 14 Nm, 790 W.

6.3.5 Control inaccuracy

- Temperature $\pm 1^{\circ}\text{C}$.
- Air flow $\pm 5\%$.

6.3.6 EMC

The air handling unit with the power supply 3-phase 400 V conforms to IEC 61000-3-12 provided that the short-circuit power Ssc is greater than or equal to the value in the table below for each size/capacity variant.

It is the duty of the installer or user of the equipment to ensure, through consultation with the distribution network operator if necessary, that the equipment is only connected to a supply with the correct short-circuit power Ssc for each unit.

For combinations of different fuse sizes/capacity variants, the short-circuit power for the air handling unit will be equal to the short-circuit power for the largest fan size/capacity variant.

GOLD RX, size - capacity variant	Short-circuit power Ssc MVA
008-2	0,9
011-2	0,9
012-1	0,9
012-2	1,3
014-1	0,9
014-2	1,3
020-1	1,4
020-2	1,7
025-1	1,4
025-2	1,7
030-1	2,1
030-2	2,7
035-1	2,1
035-2	2,7
040-1	3,4
040-2	5,7
050-1	3,4
050-2	5,7
060-1	4,1
060-2	6,5
070-1	4,1
070-2	6,5
080-1	6,6
080-2	11,3
100-1	6,6
100-2	11,3
120-1	9,9
120-2	16,8

7. Appendices

7.1 Declaration of Conformity

For Declaration of Conformity, see our home page at www.swegon.com.

7.2 Building Materials Declaration

For a complete Declaration of Construction Materials, see our home page at www.swegon.com.

7.3 License

Copyright 2013-2014 Swegon AB

All right reserved.

Parts of this work are subject to GNU General Public License v2.0 and other Free/Libre Open Source Software licenses.

This program is free software: You can redistribute it and/or modify it under the terms of the GNU General Public License as published by the Free Software Foundation, either version 3 of the License, or (at your option) any later version.

This program is distributed in the hope that it will be useful, but WITHOUT ANY WARRANTY; without even the implied warranty of MERCHANTABILITY or FITNESS FOR A PARTICULAR PURPOSE. See the GNU General Public License for more details.

You should have received a copy of the GNU General Public License along with this program. If not, see <http://www.gnu.org/licenses/>.

For full licensing conditions and the Free/Libre Open Source Software components, please visit:
<http://ftp.swegon.se/opensource/opensource/>

7.4 Ecodesign data

The air handling unit complies with the directives 2009/125/EC and 2014/53/EU.

Data for directive 2014/53/EU is available for sizing in the product selection software AHU Design.

Data for directive 327/2011/EU according to below.

Air Handling Units, EU regulation 327/2011 all fan data

Datum: 2024-02-15

AHU data				Fan data				Data according to ErP directive in technical documentation and free access webpage											
Type	Size	Motor option	Number of fans	Impeller type	Impeller diameter	Motor manufacture	Motor power	Installation category	Efficiency category	Variable speed drive	Specific ratio	Overall efficiency ηe(s)		Efficiency grade N		Power input Ped	Air Flow qv	Pressure increase pfs	Speed n
					mm		kW					Actual	Req 2015	Actual	Req 2015	kW	m³/s	Pa	min ⁻¹
GOLD SILVER C Version F RX incl. TOP	004	-	1	Aluminium	288	Domel ZKG	0,41	A	Static	Yes	1,01	65,9	48,0	79,9	62	0,463	0,514	534	2700
	005	1	1	Aluminium	288	Domel ZKG	0,8	A	Static	Yes	1,01	65,3	50,8	76,5	62	0,862	0,728	708	3380
	005	2	1	Aluminium	288	Domel ZKG	1,15	A	Static	Yes	1,01	65,2	52,0	75,1	62	1,126	0,806	840	3700
	007	1	1	Aluminium	288	Domel ZKG	0,8	A	Static	Yes	1,01	65,3	50,8	76,5	62	0,862	0,728	708	3380
	007	2	1	Aluminium	288	Domel ZKG	1,15	A	Static	Yes	1,01	65,2	52,0	75,1	62	1,126	0,806	840	3700
	008	1	1	Aluminium	348	Domel ZKG	1,15	A	Static	Yes	1,01	66,3	52,5	75,7	62	1,26	0,928	831	2780
	008	2	1	Aluminium	348	Domel ZKG	1,6	A	Static	Yes	1,01	68,9	53,6	77,3	62	1,60	1,02	1003	3050
	011	1	1	Aluminium	348	Domel ZKG	1,15	A	Static	Yes	1,01	66,3	52,5	75,7	62	1,26	0,928	831	2780
	011	2	1	Aluminium	348	Domel ZKG	1,6	A	Static	Yes	1,01	68,9	53,6	77,3	62	1,60	1,02	1003	3050
	012	1	1	Aluminium	422	Domel ZKG	1,6	A	Static	Yes	1,01	67,5	53,9	75,6	62	1,68	1,34	790	2250
	012	2	1	Aluminium	422	Domel ZKG	2,4	A	Static	Yes	1,01	67,3	55,3	74,0	62	2,30	1,48	982	2500
	014	1	1	Aluminium	422	Domel ZKG	1,6	A	Static	Yes	1,01	67,5	53,9	75,6	62	1,68	1,34	790	2250
	014	2	1	Aluminium	422	Domel ZKG	2,4	A	Static	Yes	1,01	67,3	55,3	74,0	62	2,30	1,48	982	2500
	020	1	1	Aluminium	510	Domel ZKG	2,4	A	Static	Yes	1,01	67,3	55,9	73,4	62	2,62	2,01	827	1890
	020	2	1	Aluminium	510	Domel ZKG	3,4	A	Static	Yes	1,01	67,0	57,3	71,7	62	3,56	2,25	1011	2100
	025	1	1	Aluminium	510	Domel ZKG	2,4	A	Static	Yes	1,01	67,3	55,9	73,4	62	2,62	2,01	827	1890
	025	2	1	Aluminium	510	Domel ZKG	3,4	A	Static	Yes	1,01	67,0	57,3	71,7	62	3,56	2,25	1011	2100
	030	1	1	Aluminium	616	Domel ZKG	4	A	Static	Yes	1,01	68,7	58,0	72,6	62	4,20	3,06	901	1635
	035	1	1	Aluminium	616	Domel ZKG	4	A	Static	Yes	1,01	68,7	58,0	72,6	62	4,20	3,06	901	1635
	060	1	2	Aluminium	616	Domel ZKG	4	A	Static	Yes	1,01	68,7	58,0	72,6	62	4,20	3,06	901	1635
	070	1	2	Aluminium	616	Domel ZKG	4	A	Static	Yes	1,01	68,7	58,0	72,6	62	4,20	3,06	901	1635
	030	2	1	Aluminium	616	Domel ZKG	5	A	Static	Yes	1,01	67,7	58,9	70,8	62	5,10	3,23	1028	1740
	035	2	1	Aluminium	616	Domel ZKG	5	A	Static	Yes	1,01	67,7	58,9	70,8	62	5,10	3,23	1028	1740
	060	2	2	Aluminium	616	Domel ZKG	6,5	A	Static	Yes	1,01	68,2	60,2	70,1	62	6,67	4,65	915	1380
	070	2	2	Aluminium	616	Domel ZKG	6,5	A	Static	Yes	1,01	68,2	60,2	70,1	62	6,67	3,58	1220	1900
	040	1	1	Aluminium	744	Domel ZKG	6,5	A	Static	Yes	1,01	66,4	60,2	68,2	62	6,67	4,65	915	1380
	050	1	1	Aluminium	744	Domel ZKG	6,5	A	Static	Yes	1,01	66,4	60,2	68,2	62	6,67	4,65	915	1380
	080	1	2	Aluminium	744	Domel ZKG	6,5	A	Static	Yes	1,01	66,4	60,2	68,2	62	6,67	4,65	915	1380
	100	1	2	Aluminium	744	Domel ZKG	6,5	A	Static	Yes	1,01	66,4	60,2	68,2	62	6,67	4,65	915	1380
	120	1	3	Aluminium	744	Domel ZKG	6,5	A	Static	Yes	1,01	66,4	60,2	68,2	62	6,67	4,65	915	1380
	040	2	1	Aluminium	744	Domel ZKG	9	A	Static	Yes	1,01	66,8	61,9	66,9	62	9,71	5,30	1176	1560
	050	2	1	Aluminium	744	Domel ZKG	9	A	Static	Yes	1,01	66,8	61,9	66,9	62	9,71	5,30	1176	1560
080	2	2	Aluminium	744	Domel ZKG	9	A	Static	Yes	1,01	66,8	61,9	66,9	62	9,71	5,30	1176	1560	
100	2	2	Aluminium	744	Domel ZKG	9	A	Static	Yes	1,01	66,8	61,9	66,9	62	9,71	5,30	1176	1560	
120	2	3	Aluminium	744	Domel ZKG	9	A	Static	Yes	1,01	66,8	61,9	66,9	62	9,71	5,30	1176	1560	

7.5 Digital Services

Connectivity

The product is equipped with functionality that, when enabled, will connect to the Swegon INSIDE Cloud when given access to the internet. Such connection is made either through the building's local internet access point or by using a supplied modem. When connecting through the building's internet access point, the local firewall must be configured to allow traffic according to the firewall settings. The functionality is by default disabled and can be enabled in the product. By enabling this functionality the customer agrees to the general terms and conditions for Digital Service, DS-23. The customer can disable the connection to the Swegon INSIDE Cloud in the product user interface at any time.

Which data is sent

Through the connection to Swegon INSIDE Cloud, the product will exchange data to Swegon INSIDE Cloud about certain actions and parameter settings of the product. Each data point has different thresholds for when to send data to Swegon, therefore the data sent depends on the data point type and configuration. The data is sent in intervals, at which point the data is aggregated together with other data from that interval.

Who has access to the data

The data sent to Swegon INSIDE Cloud is used by Swegon for purposes of performance, functionality and development of the product. Consequently, Swegon has the right to use the data sent from all products connected to Swegon INSIDE Cloud. The data is used in accordance with Swegon's DS-23 general terms and conditions, and our sales agreement with the customer.

Requirements

To connect a product to Swegon INSIDE Cloud, a secure internet connection via the property's internal network or via Swegon's external modem is required. In addition to a secure internet connection, a valid certificate for each individual product is also required to approve them to share data with INSIDE Cloud. Some products will come with a valid certificate out of the factory, while other products need to be equipped with a certificate to authorize the product to share data.

To find out if the product is INSIDE Ready (i.e. ready to share data) or not visit INSIDE Ready | www.swegon.com.

All documentation is available in digital form and can be downloaded from
www.swegon.com