

GOLD

Air Handling Unit

Operation & Maintenance Instructions

GOLD SD version G



Contents

| | |
|--|-----------|
| 1. Safety Instructions | 3 |
| 1.1 Safety Isolating Switch/Main Switch..... | 3 |
| 1.2 Risks | 3 |
| 1.3 Safety Guards | 3 |
| 1.4 Glycol | 3 |
| 2. General | 4 |
| 2.1 Handling the air handling unit before commissioning..... | 4 |
| 2.2 Range of Application..... | 4 |
| 2.3 Mechanical Design | 4 |
| 2.4 Control System | 4 |
| 2.5 Environmental Documentation | 4 |
| 2.6 The Components of the Air Handling Units..... | 5 |
| 2.6.1 Size 004-012, common casing..... | 5 |
| 2.6.2 Size 004-012, in split version and size 014-120..... | 6 |
| 3. Commissioning..... | 7 |
| 3.1 General..... | 7 |
| 3.2 Adjusting the Duct System and air diffusers | 8 |
| 3.2.1 Adjustment Sequence | 8 |
| 3.2.2 Commissioning procedure..... | 8 |
| 4. Maintenance..... | 9 |
| 4.1 Filter change | 9 |
| 4.1.1 Dismantling the filters | 9 |
| 4.1.2 Installing new filters | 9 |
| 4.2 Cleaning and Inspection | 10 |
| 4.2.1 General..... | 10 |
| 4.2.2 Filter spaces | 10 |
| 4.2.3 Heat exchangers | 10 |
| 4.2.4 Fans and fan spaces | 10 |
| 4.3 Service and Functionality Check..... | 11 |
| 4.4 Warranty..... | 11 |
| 5. Alarms and Troubleshooting..... | 11 |
| 5.1 General..... | 11 |
| 5.1.1 A and B Alarms | 11 |
| 5.1.2 To Reset Alarms..... | 11 |
| 5.1.3 To Change Alarm Priority..... | 11 |
| 6. Technical data..... | 12 |
| 6.1 Dimensions | 12 |
| 6.2 Connection to Wiring Terminals | 16 |
| 6.3 Electrical Data | 17 |
| 6.3.1 Air Handling Units..... | 17 |
| 6.3.2 Fans..... | 17 |
| 6.3.4 Control Inaccuracy: | 18 |
| 6.3.3 Electrical Equipment Cubicle..... | 18 |
| 6.3.5 EMC | 19 |
| 6.4 Volume of Glycol/Water in Coil Heat Exchangers, SD..... | 19 |
| 7. Appendices..... | 20 |
| 7.1 Declaration of Conformity..... | 20 |
| 7.2 Building Materials Declaration | 20 |
| 7.3 License..... | 20 |
| 7.4 Ecodesign data..... | 21 |
| 7.5 Digital Services..... | 22 |

The document was originally written in Swedish.

1. Safety Instructions

All staff concerned must acquaint themselves with these instructions before beginning any work on the unit. Any damages to the unit or parts of it due to improper handling or misuse by the purchaser or the fitter cannot be considered subject to guarantee if these instructions have not been followed correctly.



Warning

Only a qualified electrician or service personnel trained by Swegon shall be permitted to carry out any work on the electrical system or wire external functions in the air handling unit.

1.1 Safety Isolating Switch/ Main Switch

On sizes 004-080, the safety isolating switch is located on the inspection side by the inspection door of the fan section. On the size 100/120 units, the safety isolating switch is located in a plastic enclosure on the inspection side of the air handling unit.

The air handling unit should normally be started and stopped from the hand-held terminal; not by switching the safety isolating switch on and off.

Always switch off the safety isolating switch before servicing the unit if not otherwise specified in the pertinent instructions.

1.2 Risks



Warning

Before carrying out any work, make sure that the power supply to the air handling unit has been switched off.

Risk areas with moving parts

Moving parts are fan impellers.

The lockable inspection panels serve as a safety guard for the fans. If the ducts are not firmly connected to the fan outlets, the outlets must be firmly fitted with a safety guard (wire mesh screen).



Warning

The inspection doors on the filter/fan sections must not be opened while the unit is operating.
Stop the unit operating normally via the hand-held micro terminal.
Wait until the fans have stopped before opening the door.
There is positive pressure inside the fan section which could cause the door to fly open.
Keep the key at a safe spot separate from the air handling unit.

1.3 Safety Guards

The lock on the electric equipment cubicle functions as a safety guard.

Only a qualified electrician or trained service technicians shall be allowed to remove the safety guards.



Warning

The power supply to the unit shall be isolated by switching off the safety isolating switch before removing the safety guard.

When the air handling unit is operating, the safety guards must always be mounted, all inspection doors must be closed, and the junction hood on the top of the unit must be mounted.

1.4 Glycol

Glycol is used in the GOLD air handling units with coil heat exchangers.



Warning

Never pour glycol down a drain; collect it in a receptacle and leave it at a recycling centre, petrol station, etc. Glycol is highly dangerous to consume and can cause fatal poisoning or damage the kidneys. Contact a doctor! Avoid breathing glycol vapour in confined spaces. If you get glycol in your eyes, flush them thoroughly with water (for about 5 minutes). If glycol splashes on your skin, wash with soap and water.

2. General

2.1 Handling the air handling unit before commissioning

The air handling unit and its duct connections should be protected against wetness and condensation until the unit is commissioned.

2.2 Range of Application

The GOLD units are designed for use in comfort ventilation applications. Depending on the variant selected, GOLD units can be utilised in buildings such as office buildings, schools, day nurseries, public buildings, shops, residential buildings, etc.

The GOLD SD units can also be used for the ventilation of moderately humid buildings; however not where the humidity is continuously high, such as in indoor swimming baths.

The GOLD SD is designed for applications where the supply air and extract air need to be completely separated or where, due to limited available space, separate units for supply air and extract air respectively are needed. They can also be used individually if only one of the variants is needed.

In order to fully obtain all the benefits the GOLD system has to offer, it is important to take the special characteristics of the air handling units into account when planning them into the project, installing, commissioning and operating them.

The air handling unit in its basic design should be installed indoors. The TBTA/TBTB accessory should be used if the air handling units are installed outdoors. If the duct accessories are installed outdoors, they must be housed in an insulated casing (type TCxx).

GOLD SD is designed and tested for temperatures, in the surroundings and the air stream, from -40°C to +40°C. If the air handling unit is placed outdoors and contains a pipework package from Swegon, the expansion vessel must be equipped with anti-freeze resistance and insulated when the design outdoor temperature is lower than -10 °C.

The fans are approved for continuous operation in temperatures of up to 40°C.

The fans are tested for, and can manage operation for one hour at 70°C.



Important!

Always read the safety instructions in Section 1 that explain the risks involved in running the unit and designate who shall be permitted to operate and service the unit, and carefully follow the installation instructions provided in each paragraph.

The product identification plates are located on the inspection side of the air handling unit and on a wall inside the fan section. Refer to the particulars on the product identification plate when you contact Swegon.

2.3 Mechanical Design

The GOLD is available in 9 physical sizes and for 18 airflow ranges.

GOLD SD size 004-012 in common casing equipped with pleated filters ePM10 60% (M5) or ePM1 50% (F7). Other variants/sizes have supply air filters and extract air filters made of glass fibre in filter class ePM10 60% (M5) or ePM1 60% (F7).

For GOLD SD there are coil heat exchangers and loose pipe packages available as accessories.

The supply air and extract air fans are of GOLD Wing+ type, an axi-centrifugal fan with backward-curved blades. The fans are direct-driven and have a motor control system for variable speed control.

2.4 Control System

The IQlogic control system is microprocessor-based and is integrated into the air handling unit. It controls and regulates the fans, heat exchanger, temperatures, airflows, Operation times and a large number of internal and external functions as well as alarms.

2.5 Environmental Documentation

For a complete Declaration of Construction Materials, see our home page at www.swegon.com (applicable to Sweden only).

The air handling unit is designed in such a way that it can be easily dismantled into its component parts. When the unit has ended its useful product life, the services of an accredited recycling company should be utilised for disposal.

The recyclable weight of the GOLD is about 94% of its initial weight.

Swegon AB is associated with the REPA Register, No. 5560778465.

Contact Swegon AB, Phone: +46 (0)512-322 00, if you have any questions regarding the dismantling instructions or the air handling unit's impact on the environment.

2.6 The Components of the Air Handling Units

2.6.1 Size 004-012, common casing

The individual components are each specified below in a simplified and diagrammatical description.

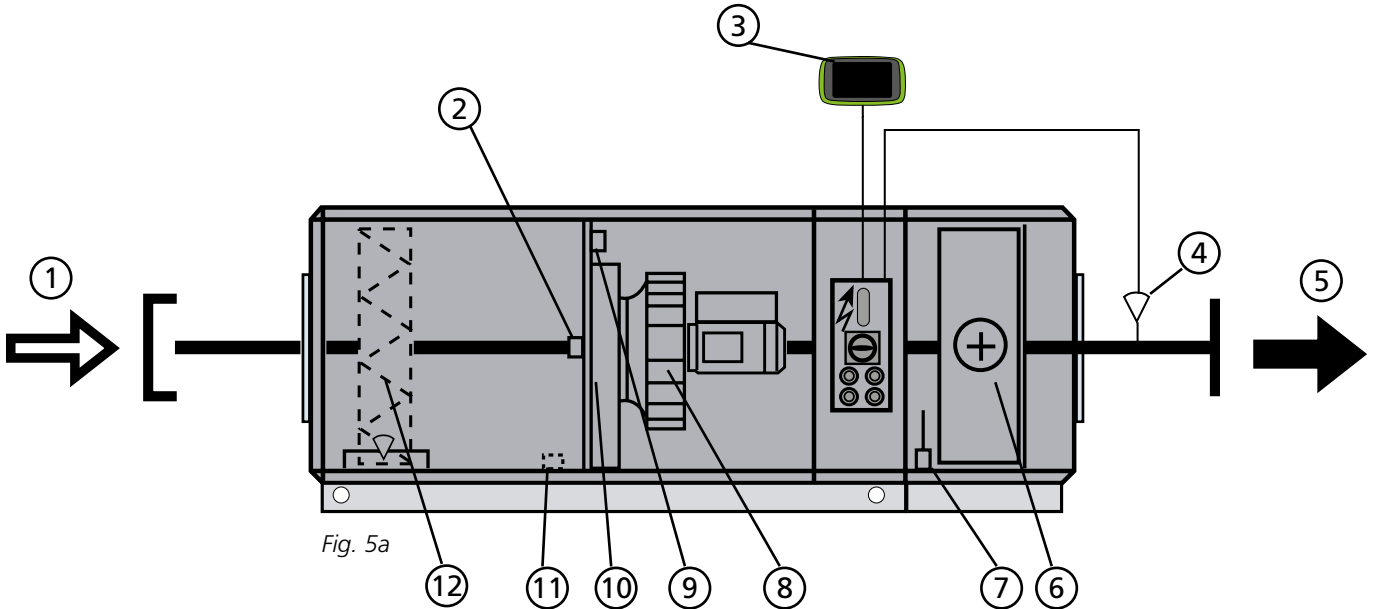

Fig. 5a

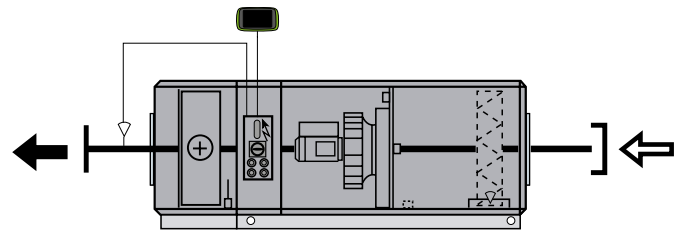

Fig. 5b

The air handling units can be ordered in the right-hand version as shown in Fig. 5a or the left-hand version as shown in Fig. 5b. The air handling units can also consist of filter and fan only or fan only.

The air handling unit is shown here as a supply air handling unit. If the unit is used as an extract air handling unit, the components marked with an asterisk change function and designation (the components are named according to whether the function is for supply air or extract air).

The arrangement of the components and their designations

- | | |
|--|--|
| <ul style="list-style-type: none"> 1 OUTDOOR AIR* (In extract air units: Extract air) 2 Temperature sensor, outdoor air/air density sensor, supply air* (In extract air units: Temperature sensor, extract air/air density sensor, exhaust air) 3 Handheld terminal 4 Temperature sensor, supply air (to be mounted in supply air duct) (Not used in extract air units) 5 SUPPLY AIR* (In extract air units: Exhaust air) | <ul style="list-style-type: none"> 6 Coil heat exchanger, supply air*, if applicable (In extract air units: Coil heat exchanger, extract air) 7 Sensor, Outdoor temperature* (For air handling units with coil heat exchanger only) (For extract air units: Extract air temperature/relative humidity sensor) 8 Supply air fan* with motor and motor controller (In extract air handling units: Extract air fan with motor and motor controller) 9 Pressure sensor, supply air fan* (In extract air units: Pressure sensor, extract air fan) 10 Electrical equipm. cubicle with control unit 11 Pressure sensor, supply air filter*, if applicable (In extract air handling units: Pressure sensor, extract air filter) 12 Supply air filter*, if applicable (In extract air units: Extract air filter) |
|--|--|

2.6.2 Size 004-012, in split version and size 014-120

The individual components are each specified below in a simplified and diagrammatical description.

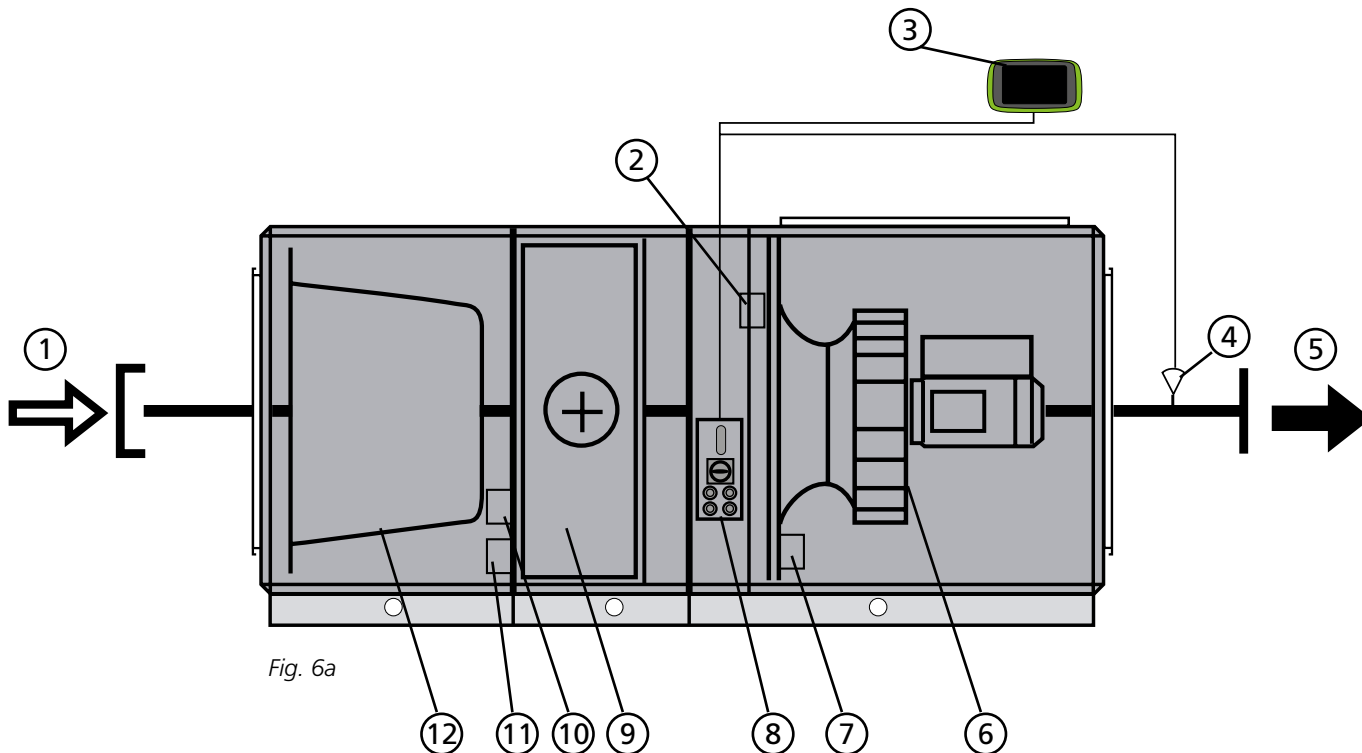

Fig. 6a

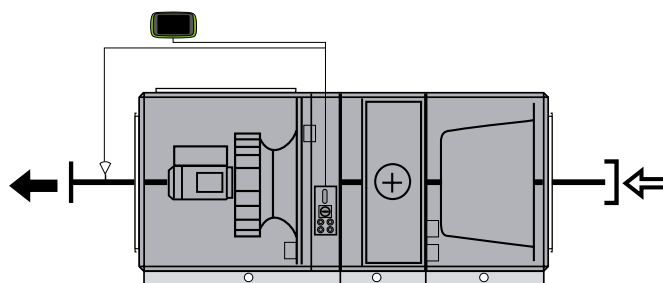

Fig. 6b

The air handling units can be ordered in the right-hand version as shown in Fig. 6a or the left-hand version as shown in Fig. 6b. The air handling units can also consist of filter and fan only or fan only.

The air handling unit is shown here as a supply air handling unit. If the unit is used as an extract air handling unit, the components marked with an asterisk change function and designation (the components are named according to whether the function is for supply air or extract air).

The arrangement of the components and their designations

- 1 OUTDOOR AIR*
(In extract air units: Extract air)
- 2 Temperature sensor, outdoor air/air density sensor, supply air*
(In extract air units: Temperature sensor, extract air/air density sensor, exhaust air)
- 3 Handheld terminal
- 4 Temperature sensor, supply air (to be mounted in supply air duct)
(Not used in extract air units)
- 5 SUPPLY AIR*
(In extract air units: Exhaust air)
- 6 Supply air fan* with motor and motor controller
(In extract air handling units: Extract air fan with motor and motor controller)
- 7 Pressure sensor, supply air fan*
(In extract air units: Pressure sensor, extract air fan)
- 8 Electrical equipm. cubicle with control unit
- 9 Coil heat exchanger, supply air*, if applicable
(In extract air units: Coil heat exchanger, extract air)
- 10 Sensor, Outdoor temperature*
(For extract air units: Extract air temperature/relative humidity sensor)
- 11 Pressure sensor, supply air filter*
(In extract air units: Pressure sensor, extract air filter)
- 12 Supply air filter*, if applicable
(In extract air units: Extract air filter)

3. Commissioning

3.1 General

Commissioning sequence:

1. Check that there are no foreign objects inside the unit, duct system or functional sections.
2. Turn the safety isolating switch to the ON position (I).
3. Select the appropriate language, if you have not already done so. See Section 4.7 in the GOLD Function Manual, Installation
4. The air handling unit has a factory setting that makes it ready to operate. See separate Commissioning Record.

However, in many cases, these settings need to be adjusted to suit the current installation.

If necessary, enter the fan position setting (inspection side), see Section 4.10 in the Function Manual, Installation.

Program the time switch, operating mode, temperatures, airflows and functions according to the procedures in Section 4 in the Function Manual, Installation.

Select whether the airflow unit of measurement shall be l/s, m³/s, m³/h or cfm.

Fill out the Commissioning Record and save it in the document pocket of the air handling unit.

In some cases it might be necessary to adjust the P-band and the I-time if the heating regulation system is oscillating or operates sluggishly. This requires entering a special code. Contact your Swegon representative.

5. Activate, if needed, manual or auto operation (Dashboard) or lock the speed of the fans (AIRFLOW ADJUSTMENT image). Adjust the duct system and the air diffusers according to Section 3.2.
6. Check and adjust, if required, the pressure balance in the air handling unit according to Section 3.3.
7. Finish with filter calibration according to Section 3 in the Function Manual, Installation.

3.2 Adjusting the Duct System and air diffusers

In order to prevent the fans from consuming more power than necessary, it is important to keep the pressure drop in the system at the lowest possible level. It is also important that duct systems and air diffusers are correctly commissioned to provide the comfort expected.

When commissioning air diffusers and the duct systems for the GOLD, it is appropriate to follow the proportionality method.

This means that the ratio between the airflows in branch ducts remains constant even if you change the airflow in the main ducts. The same ratio applies to the air diffusers in the installation.

When commissioning the duct system there is provision for locking the speed of the fans in the air handling unit to provide a specific preset flow rate, see Section 4.1.7 in the Function Manual, Installation.

3.2.1 Adjustment Sequence

The system should be adjusted in the following order:

1. Adjust of the air diffusers in each branch duct.
2. Adjust the branch ducts.
3. Adjust the main ducts.

3.2.2 Commissioning procedure

1. Set all the air diffusers and dampers to the fully open position.
2. Calculate the quotient between the airflow reading and the design airflow of all the air diffusers, branch ducts and main ducts. The air diffuser in every branch that has the lowest quotient should be fully open. Use this air diffuser as an INDEX AIR DIFFUSER. The same applies to branch dampers and main dampers.

When you've finished commissioning, one air diffuser in every branch, one branch damper and one main damper should consequently be fully open.

3. Start adjusting the main duct that has the highest quotient and the branch duct in the main duct that has the highest quotient. Starting from this point enables you to then "press" the air in front of you toward the sections of the system that have the least air.
4. Adjust the last air diffuser on the duct branch so that it will have the same quotient as the index air diffuser. This air diffuser becomes the REFERENCE AIR DIFFUSER. The last air diffuser on the branch is often the one that has the lowest quotient and this air diffuser should be open. In this case, the index air diffuser and the reference air diffuser will be one and the same.
5. Throttle the other air diffusers in the branch to the same quotient as the reference device.

NOTE! The quotient in the reference terminal will change every time another air diffuser is throttled, so in practice the quotient for the reference air diffuser can be set slightly higher. The reference device must be measured in between each air diffuser throttled.

6. Go to the branch that had the next highest quotient and adjust the air diffusers there, etc.
7. Throttle the branch damper that had the highest quotient to the same quotient as the branch that had the lowest quotient.

NOTE! Keep in mind that the index damper changes quotient; proceed as described in item 5.

8. When all branches have been commissioned, throttle the main dampers in the same manner.

See also Adjustment example below.

Example on how to make an adjustment

– Start adjusting duct branch B, since this one has the highest quotient.

– The last air device, B3, has the lowest quotient and should be fully open.

Adjust the other air devices, B1 and B2, so that these will have the same quotient as air device B3 (see item 5 above).

– Now adjust the air devices in branch duct C. Air device C4 should be fully open; throttle the others to the same quotient.

– Adjust the air devices in branch duct A. The index air device here is air device A3, which means that you first throttle air device A4 (the reference device) to device A3's quotient. Then adjust the others to the same quotient as air device A4.

– Throttle branch damper B to the same quotient as branch damper A, throttle branch damper C to the same quotient as branch damper A.

Check that all dampers have the same quotient.

When commissioning has been completed, 3 air devices and one branch damper should stand fully open to obtain the lowest possible pressure in the system.

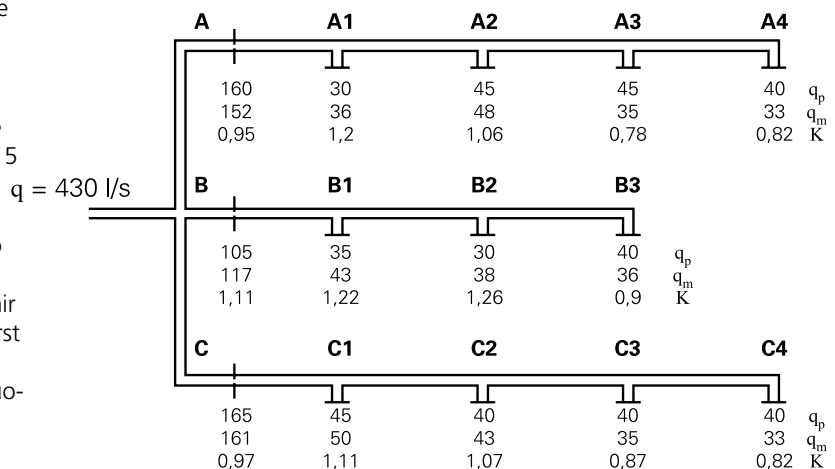

qp = design airflow (l/s)

qm = flow reading (l/s)

$$K \text{ (Quotient)} = \frac{qm}{qp}$$

4. Maintenance



Warning

Before carrying out any work, make sure that the power supply to the air handling unit has been switched off.

4.1 Filter change

Filters made of glass fibre should be replaced, and if a pre-filter made of woven aluminium is fitted, it should be washed, when the corresponding filter alarm has been activated.

Order new filters from Swegon or your nearest Swegon representative. Specify the size of the GOLD unit, whether the replacement concerns one or two directions of airflow and if you are replacing standard filters and/or possibly a pre-filter.

4.1.1 Dismantling the filters

It is advisable to clean inside the filter space while the filters are removed.

Standard filters:

Pull out the handles (A) to free the filters from the filter holder. Withdraw the filters.

Possible pre-filters inside the air handling unit:

Withdraw the filters.

4.1.2 Installing new filters

Standard filters:

Insert the filters into the filter holder. At the same time, draw out the filter bags, if installed, so that they will not become caught, damaged or folded.

Insert the filters as far as possible into the unit and press them lightly against the filter frames, so that they fit tightly.

Push in the handles (A) to clamp the filters in position in the filter holder.

Close the inspection doors.

Finish with filter calibration according to Section 2 in the Function Manual, Users.

Pre-filters, if installed, in the AHU:

Insert the filters in the filter guide rails as far as possible into the AHU and press them lightly against the filter frames, so that they fit tightly.

Finish with filter calibration according to Section 2 in the Function Manual, Users.

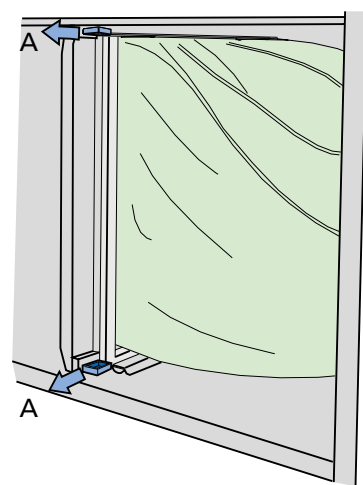

4.2 Cleaning and Inspection

4.2.1 General

Access for cleaning must be ensured when planning and during the installation of the air handling unit. This can, for example, include the set-up of the unit, and pipe and cable routing.

Clean the interior of the air handling unit if needed. Inspection of the air handling unit should be performed when you change filters or at least twice a year.

4.2.2 Filter spaces

The most appropriate time to clean the unit is when you change the filters.

4.2.3 Heat exchangers

Check whether cleaning is necessary at least twice a year. Cleaning can be done from the filter space.

Make sure that the coils are purged of air. If a droplet eliminator is fitted, remove it and flush it clean with water.

Always clean against the regular direction of airflow.

Cleaning must only be done by blowing with compressed air, vacuum cleaning with a soft nozzle or wet cleaning with water and/or solvent. Before you begin cleaning, cover adjacent functional sections to protect them.

If cleaning solvent is used, do not use solvent that will corrode aluminium or copper. Swegon's cleaning agent is recommended. This cleaning agent is sold by Swegon Service.

While cleaning, check whether venting is necessary, check the content of glycol in the water and the condition of the coil for leakage. Also check that the drain is not clogged.

4.2.4 Fans and fan spaces

Inspect and, if needed, clean the fan impellers to remove dirt deposits.

Check the impeller to make sure that it is not out of balance.

Check the bearings for noise.

Vacuum clean the fan motor or brush its surfaces. It can also be cleaned by carefully wiping it with a damp cloth and dishwashing detergent.

Clean the fan space, if needed.

4.3 Service and Functionality Check

Service and functionality inspections shall be carried out at the interval specified below.

| Item to check | Action | 6-monthly service | 12-monthly service |
|---|--|-------------------|--------------------|
| Service | | | |
| Filters | To be replaced when the display screen indicates a filter alarm. Check that the filter installation frame is in working order and is tight. | | x |
| Fans, heat exchangers, duct accessories | Inspect and clean if necessary. | x | |
| Internal surfaces | Inspect and clean if necessary. | x | |
| External surfaces | Inspect and clean if necessary. | | x |
| Gaskets, sealing strips, bearings, drive belts | Inspect and remedy if necessary. | | x |
| Sensors, cabling, measuring tubes | Carry out visual inspection and remedy if necessary. | | x |
| Functionality inspection | | | |
| Safety functions, fire and frost protection, etc. | To inspect the functionality. | | x |
| Other control functions | To inspect the functionality. Compare the air handling unit's values with the commissioning report. Remedial measures should be taken to correct any possible inconsistencies. | | x |
| Alarm history | Review. | x | |

4.4 Warranty

To submit a warranty claim, you must be able to produce a complete documented and signed Service and Functionality Inspection Report of the product with hits accessories.

A Service and Functionality Inspection Report must be performed according to the instructions in Sections 4.1, 4.2 and 4.3.

General conditions for warranty liability are given in the delivery provisions applicable to the supply.

5. Alarms and Troubleshooting

5.1 General

Alarms are displayed by a flashing red LED in the hand-held terminal.

When the LED flashes, go in under Alarm log in the instrument panel, see Section 2.2.3 in the Operating Procedures Manual of the IQnavigator hand-held micro terminal.

Active alarms, pending alarms and alarm history (50 latest) can be viewed under Alarm log.

For resetting alarms, you can select individual alarms or all the alarms.

The reset time can also be viewed under History.

A fault can be traced by examining the function or functional component indicated in the alarm text.

If the fault cannot be immediately remedied:

Consider whether the air handling unit can continue to operate until the fault has been remedied. Choose to block the alarm and/or to change it from stop to operation. See Section 4.8.6 in the Function Manual, Installation.

5.1.1 A and B Alarms

A alarms send an indication to the output for alarm relay A (IQlogic module*).

B alarms send an indication to the output for alarm relay B (IQlogic module*).

Alarms can be forwarded with different priority via these relays.

5.1.2 To Reset Alarms

Alarms with manual resetting can be reset from the hand-held terminal. Select reset in the alarm log.

Alarms that reset themselves automatically will do so as soon as the fault has been remedied.

Alarms can also be reset via a communication network (not applicable to frost guard alarm).

5.1.3 To Change Alarm Priority

See Section 4.8.6 in the Function Manual, Installation.

6. Technical data

6.1 Dimensions

GOLD 004-008, common casing

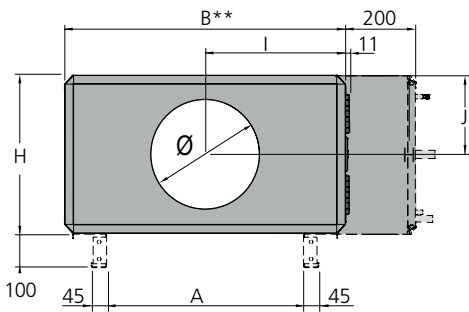
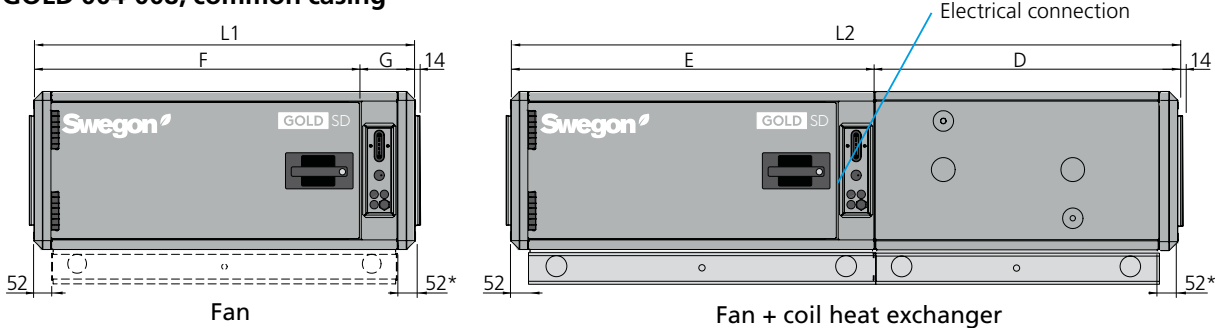

* The air handling unit is supplied without end connection panel if a duct accessory housed in an insulated casing will be connected. The AHU can also be supplied with full face end connection panel (accessory).

** Width of coil heat exchanger (if required) = B + 200 mm.

Base beams are optional for air handling units without coil heat exchangers.
Base beams are standard on air handling units with coil heat exchangers.

| Size | Weight, kg fan+filter | Weight, kg fan + filter + coil |
|---------|--------------------------|-----------------------------------|
| 004/005 | 97-118 | 210-236 |
| 007 | 115-145 | 255-291 |
| 008 | 122-149 | 262-295 |

| Size | L1 | L2 | B | H | A | D | E | F | G | I | J | Ø |
|---------|------|------|-----|-------|-----|-----|------|------|-----|-------|-----|-----|
| 004/005 | 1120 | 1955 | 825 | 460 | 579 | 887 | 1068 | 956 | 164 | 412.5 | 230 | 315 |
| 007/008 | 1214 | 2049 | 995 | 542.5 | 749 | 887 | 1162 | 1050 | 164 | 497.5 | 271 | 400 |

GOLD 004-008, split version

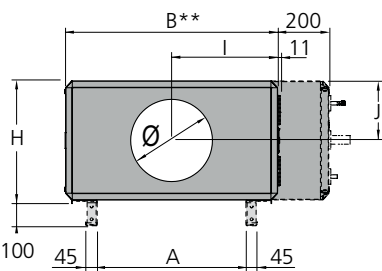
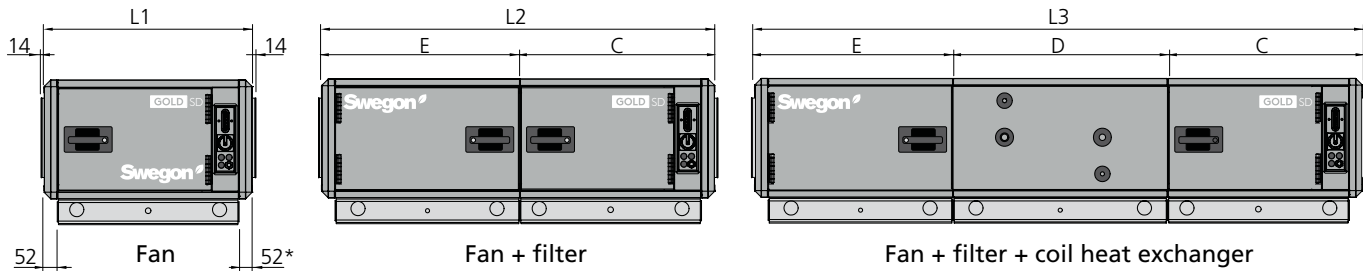

* The air handling unit is supplied without end connection panel if a duct accessory housed in an insulated casing will be connected. The AHU can also be supplied with full face end connection panel (accessory).

** Width of coil heat exchanger (if required) = B + 200 mm.

| Size | Weight, kg fan | Weight, kg fan+filter | Weight, kg fan + filter + coil |
|---------|-------------------|--------------------------|-----------------------------------|
| 004/005 | 68-85 | 119-140 | 232-258 |
| 007 | 79-100 | 138-164 | 278-310 |
| 008 | 86-107 | 145-171 | 285-317 |

| Size | L1 | L2 | L3 | B | H | A | C | D | E | I | J | Ø |
|---------|-----|------|------|-----|-------|-----|-----|-----|-----|-------|-----|-----|
| 004/005 | 809 | 1529 | 2364 | 825 | 460 | 579 | 757 | 835 | 772 | 412 | 230 | 315 |
| 007/008 | 809 | 1529 | 2364 | 995 | 542.5 | 749 | 757 | 835 | 772 | 497.5 | 271 | 400 |

GOLD 011/012, common casing

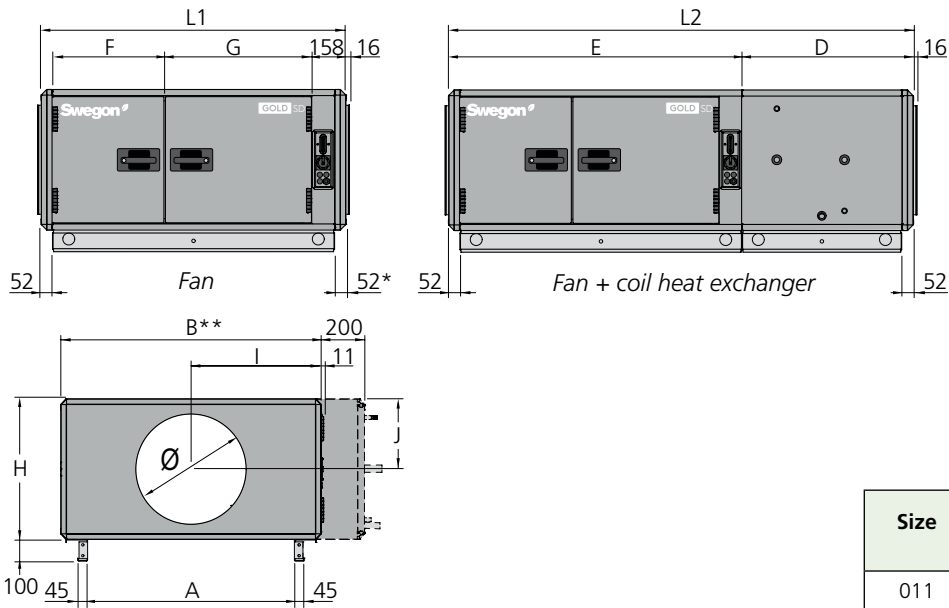

* The air handling unit is supplied without end connection panel if a duct accessory housed in an insulated casing will be connected. The AHU can also be supplied with full face end connection panel (accessory).
 ** Width of coil heat exchanger (if required) = B + 200 mm.

| Size | Weight, kg fan+filter | Weight, kg fan + filter + coil |
|------|-----------------------|--------------------------------|
| 011 | 164-203 | 348-393 |
| 012 | 175-217 | 359-407 |

| Size | L1 | L2 | B | H | A | D | E | F | G | I | J | Ø |
|---------|------|------|------|-------|-----|-----|------|-----|-----|-------|-----|-----|
| 011/012 | 1404 | 2239 | 1199 | 647.5 | 953 | 887 | 1352 | 513 | 681 | 599.5 | 324 | 500 |

GOLD 011/012, split version

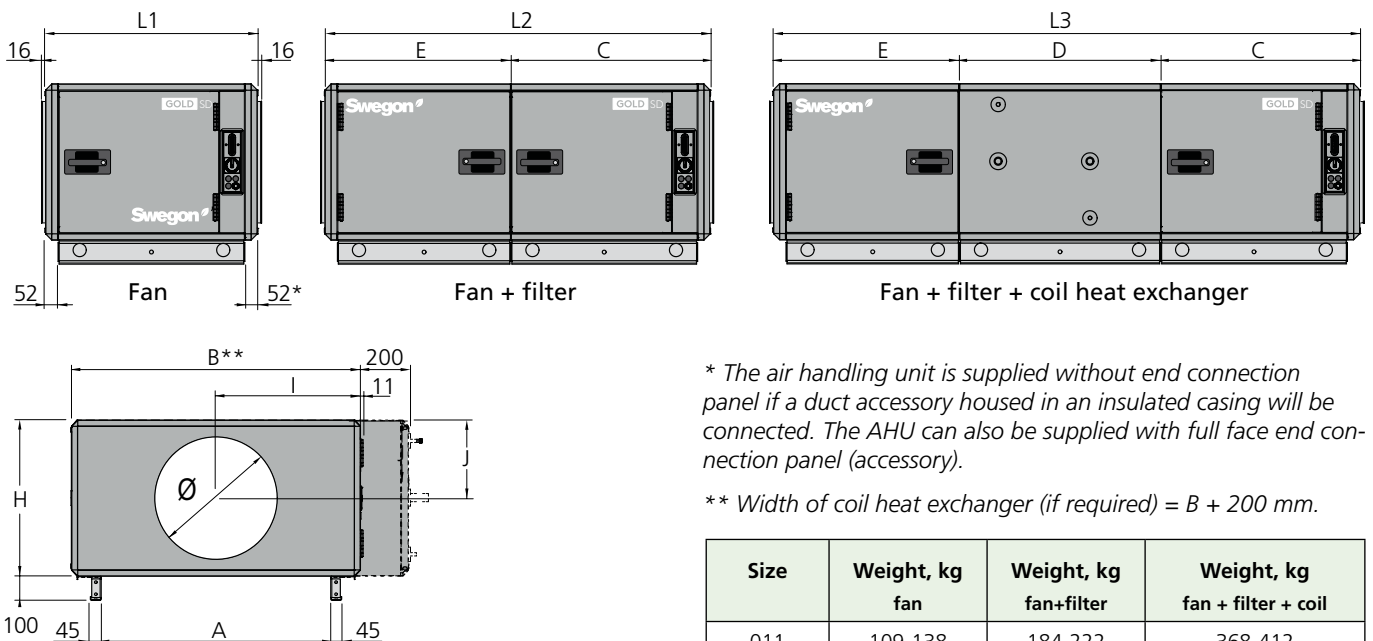

* The air handling unit is supplied without end connection panel if a duct accessory housed in an insulated casing will be connected. The AHU can also be supplied with full face end connection panel (accessory).

** Width of coil heat exchanger (if required) = B + 200 mm.

| Size | Weight, kg fan | Weight, kg fan+filter | Weight, kg fan + filter + coil |
|------|----------------|-----------------------|--------------------------------|
| 011 | 109-138 | 184-222 | 368-412 |
| 012 | 120-149 | 195-233 | 379-423 |

| Size | L1 | L2 | L3 | B | H | A | C | D | E | I | J | Ø |
|---------|-----|------|------|------|-------|-----|-----|-----|-----|-------|-----|-----|
| 011/012 | 878 | 1598 | 2433 | 1199 | 647.5 | 953 | 828 | 835 | 772 | 599.5 | 324 | 400 |

GOLD 014/020, 025/030, 035/040

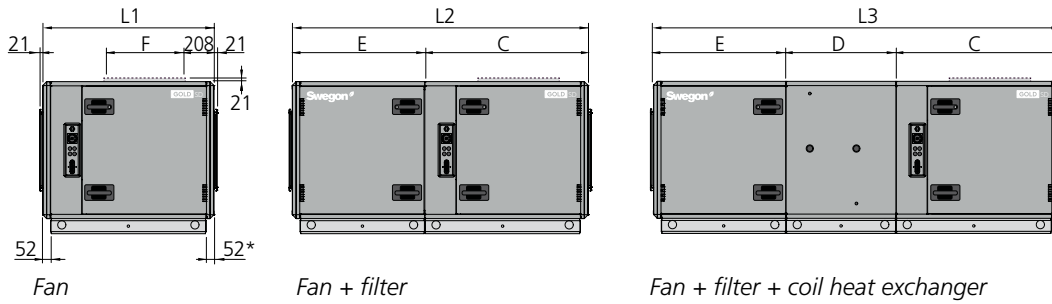

* If the duct accessory is housed in an insulated casing, the AHU is supplied without end connection panel; the AHU can also be supplied with full face end connection panel (accessory).

** Width of coil heat exchanger (if applicable) = $B + 200$ mm.

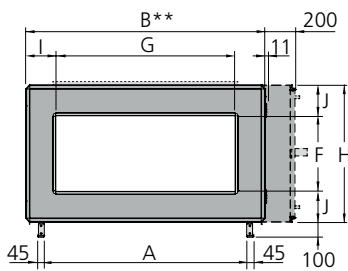

| Size | Weight, kg fan | Weight, kg fan+filter | Weight, kg fan + filter + coil |
|------|----------------|-----------------------|--------------------------------|
| 014 | 148-191 | 250-304 | 506-567 |
| 020 | 158-211 | 260-324 | 516-587 |
| 025 | 190-252 | 308-382 | 616-699 |
| 030 | 216-264 | 351-411 | 659-728 |
| 035 | 263-332 | 413-513 | 853-966 |
| 040 | 288-366 | 438-547 | 878-1000 |

| Size | L1 | L2 | L3 | B | H | A | C | D | E | F | G | I | J |
|---------|------|------|------|------|--------|------|------|-----|-----|-----|------|-----|-------|
| 014/020 | 1040 | 1875 | 2710 | 1400 | 775,5 | 1154 | 988 | 835 | 887 | 400 | 1000 | 200 | 188 |
| 025/030 | 1144 | 1978 | 2813 | 1600 | 905,5 | 1354 | 1092 | 835 | 886 | 500 | 1200 | 200 | 203 |
| 035/040 | 1253 | 2088 | 2988 | 1990 | 1079,5 | 1744 | 1202 | 900 | 886 | 600 | 1400 | 295 | 239,5 |

GOLD 050/060

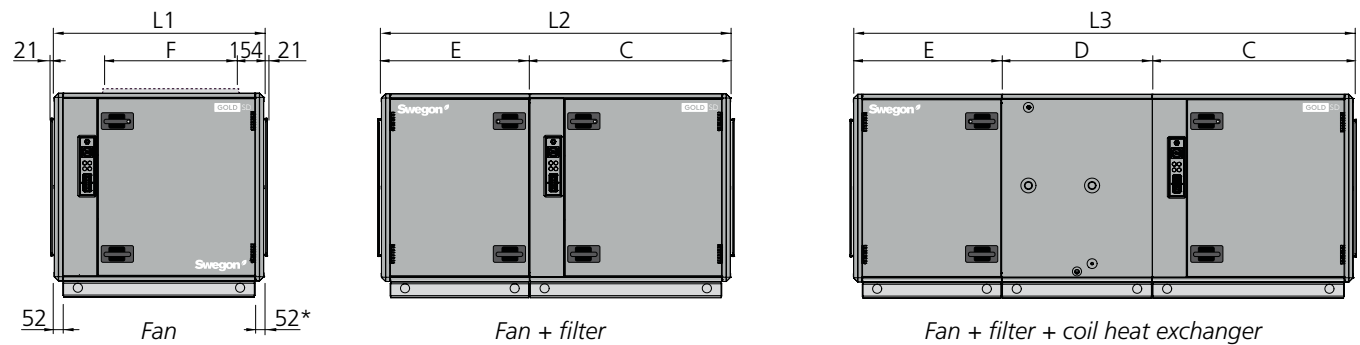

* If the duct accessory is housed in an insulated casing, the AHU is supplied without end connection panel; the AHU can also be supplied with full face end connection panel (accessory).

** Width of coil heat exchanger (if applicable) = $B + 200$ mm.

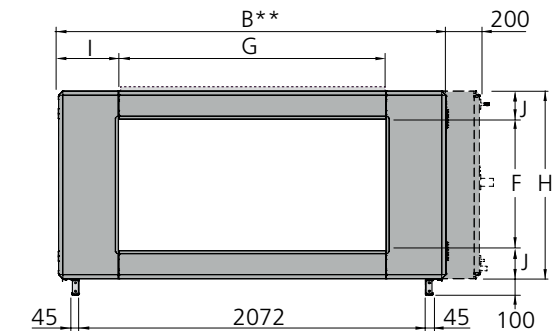

| Size | Weight, kg fan | Weight, kg fan+filter | Weight, kg fan + filter + coil |
|------|----------------|-----------------------|--------------------------------|
| 050 | 331-410 | 516-634 | 1058-1190 |
| 060 | 404-474 | 589-698 | 1131-1254 |

| Size | L1 | L2 | L3 | B | H | C | D | E | F | G | I | J |
|---------|------|------|------|------|------|------|-----|-----|-----|------|-----|-----|
| 050/060 | 1253 | 2088 | 2988 | 2318 | 1144 | 1202 | 900 | 886 | 800 | 1600 | 359 | 172 |

GOLD 070/080

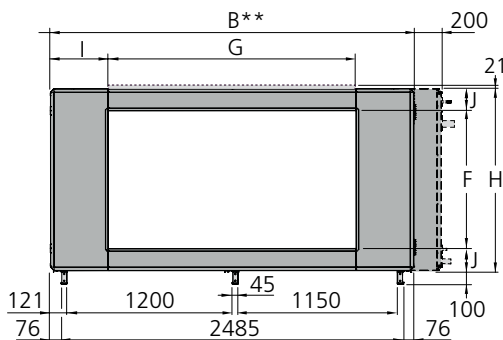
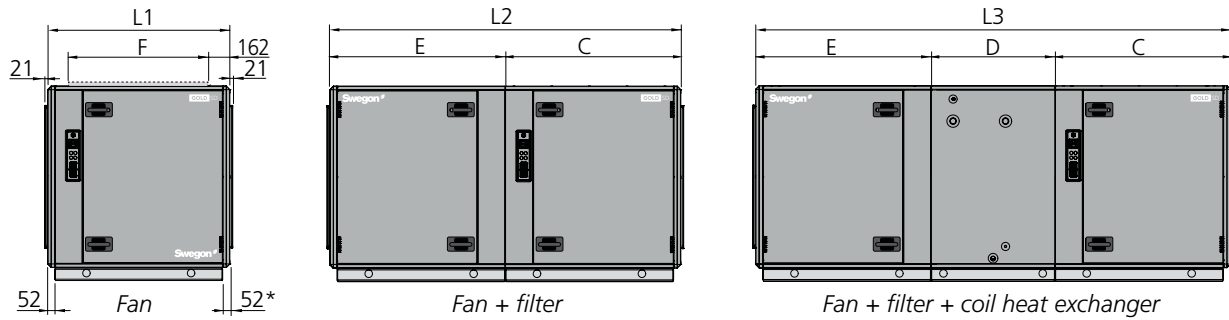

* If the duct accessory is housed in an insulated casing, the AHU is supplied without end connection panel; the AHU can also be supplied with full face end connection panel (accessory).

** Width of coil heat exchanger (if applicable) = B + 200 mm.

| Size | Weight, kg fan | Weight, kg fan+filter | Weight, kg fan + filter + coil |
|------|----------------|-----------------------|--------------------------------|
| 070 | 496-578 | 791-918 | 1494-1633 |
| 080 | 523-623 | 818-963 | 1521-1678 |

| Size | L1 | L2 | L3 | B | H | C | D | E | F | G | I | J |
|---------|------|------|------|------|------|--------|-----|--------|------|------|-------|-----|
| 070/080 | 1325 | 2547 | 3447 | 2637 | 1320 | 1273,5 | 900 | 1273,5 | 1000 | 1800 | 418,5 | 160 |

GOLD 100/120

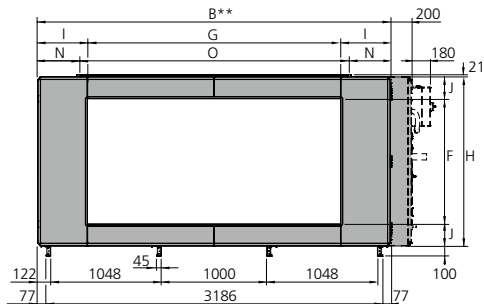
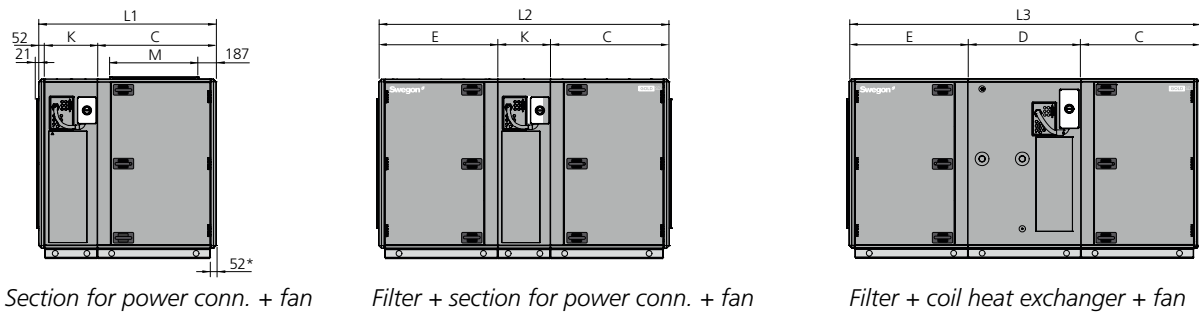

* If the duct accessory is housed in an insulated casing, the AHU is supplied without end connection panel; the AHU can also be supplied with full face end connection panel (accessory).

** Width of coil heat exchanger (if applicable) = B + 200 mm.

| Size | Weight, kg section for power connection + fan | Weight, kg filter + section for power conn. + fan | Weight, kg filter + coil + fan |
|------|---|---|--------------------------------|
| 100 | 861-937 | 1263-1477 | 2133-2372 |
| 120 | 961-1046 | 1363-1586 | 2233-2481 |

| Size | L1 | L2 | L3 | B | H | C | D | E | F | G | I | J | K | M | N | O |
|---------|------|------|------|------|------|------|------|------|------|------|-----|-----|-----|-----|-----|------|
| 100/120 | 1673 | 2744 | 3314 | 3340 | 1620 | 1122 | 1070 | 1122 | 1200 | 2400 | 470 | 210 | 500 | 800 | 420 | 2500 |

6.2 Connection to Wiring Terminals

The max. permissible load on the corresponding connection is 16 VA.

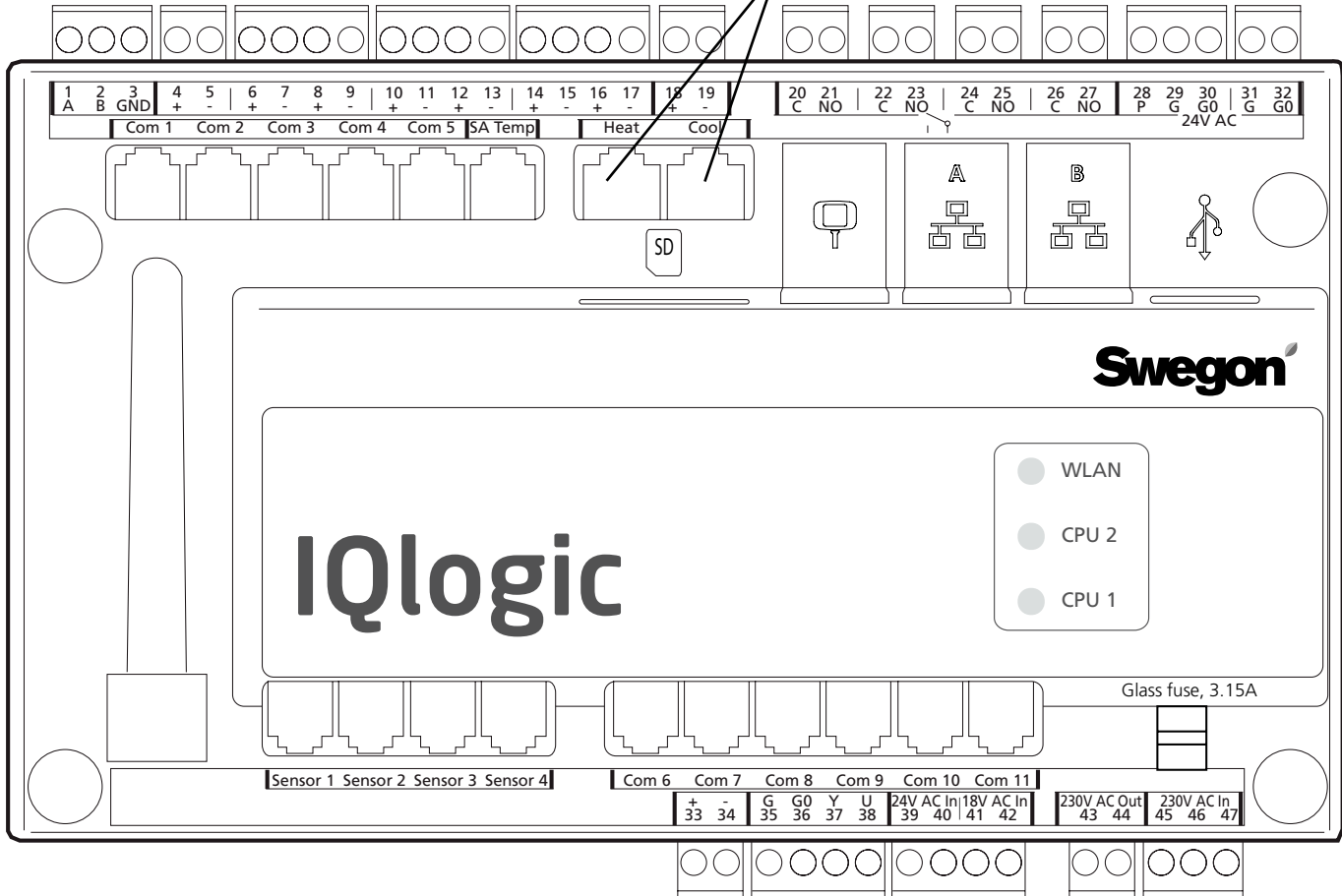

Digital inputs, terminals 4-17, are of extra-low voltage type. Analogue input, terminals 18-19 have an input impedance of 66 kΩ. 230 VAC control voltage is on external terminals 101 (L) and 102 (N).

| Wiring terminal | Function | Remarks |
|-----------------|---|--|
| 1,2,3 | Connections for EIA -485 | 1= Communication connection A/RT+, 2= Communication connection B/RT-, 3= GND/COM. |
| 4,5 | External stop | Stops the unit by opening the circuit. On delivery, this function is fitted with a jumper. If the connection is interrupted, the unit will stop. |
| 6,7 | External fire/smoke function 1 | External fire and smoke function. On delivery, this function is fitted with a jumper. If the connection is interrupted, the function will trip and initiate an alarm. |
| 8,9 | External fire/smoke function 2 | External fire and smoke function. On delivery, this function is fitted with a jumper. If the connection is interrupted, the function will trip and initiate an alarm. |
| 10,11 | External alarm 1 | External contact function. Optional: Normally open/normally closed. |
| 12,13 | External alarm 2 | External contact function. Optional: Normally open/normally closed. |
| 14,15 | External low speed | External contact function. Oversteers the timer from stop to low speed operation. |
| 16,17 | External high speed | External contact function. Oversteers the timer from stop or low speed to high speed operation. |
| 18,19 | Demand control | Input for 0-10 V DC. The input signal influences the supply air/extract airflow set point if the unit is operating in the demand control mode. For connection of sensors, for example CO ₂ , CO and VOC |
| 20,21 | Circulation pump, heating circuit | Independent contact, max. 5 A/AC1, 2 A/AC3, 250 VAC. Closes on a heating load. |
| 22,23 | Circulation pump, cooling circuit or cooling on/off, 1-step operation | Independent contact, max. 5 A/AC1, 2 A/AC3, 250 VAC. Closes on a cooling load. |
| 24,25 | Cooling, on/off, 2-step operation | Independent contact, max. 5 A/AC1, 2 A/AC3, 250 VAC. Closes on a cooling load. |
| 26,27 | In-operation indication | Independent contact, max. 5 A/AC1, 2 A/AC3, 250 VAC. Closes when the unit is operating. |
| 28,29,30 | Damper control | 24 VAC. 28= Controlled 24 VAC (G), 29= 24 VAC (G), 30= 24 VAC (GO). |
| 31,32 | Control voltage ¹⁾ | 24 VAC control voltage. Terminals 31-32 are loaded with a total of 16 VA. Opened by means of the safety isolating switch. |
| 33,34 | Reference voltage | Output for constant 10 VDC. Max. permissible load: 8 mA. |
| 35,36,37,38 | Control, recirculation damper | The recirculation damper can be loaded with max. 2 mA at 10 VDC. 35= 24 V AC (G), 36= 24 V AC (GO), 37= 0-10 V DC control signal, 38= 0-10 VDC feedback signal. |

The max permissible common load on terminals 31-32, outputs for Heat/Cool and damper output (terminals 28-30) is max 32 VA (SD) eller 50 VA (RX/PIX/CX).

¹⁾ GOLD 100/120: If more than 16 VA is required, use wiring terminals 201 (G) and 202 (GO). Terminals 201-202 can be loaded with a total of max, 48 VA.

6.3 Electrical Data

6.3.1 Air Handling Units

MIN. POWER SUPPLY

GOLD 004:

1-phase, 3-wire, 230 V -10/+15%, 50 Hz, 10 AT

GOLD 005, capacity variant 1:

1-phase, 3-wire, 230 V -10/+15%, 50 Hz, 10 AT

GOLD 005, capacity variant 2:

1-phase, 3-wire, 230 V -10/+15%, 50 Hz, 10 AT

GOLD 007, capacity variant 1:

1-phase, 3-wire, 230 V -10/+15%, 50 Hz, 10 AT

GOLD 007, capacity variant 2:

1-phase, 3-wire, 230 V -10/+15%, 50 Hz, 10 AT

GOLD 008, capacity variant 1:

1-phase, 3-wire, 230 V -10/+15%, 50 Hz, 10 AT

GOLD 008, capacity variant 2:

3-phase, 5-wire, 400 V -10/+15%, 50 Hz, 10 AT

GOLD 011, capacity variant 1:

1-phase, 3-wire, 230 V -10/+15%, 50 Hz, 10 AT

GOLD 011, capacity variant 2:

3-phase, 5-wire, 400 V -10/+15%, 50 Hz, 10 AT

GOLD 012–035:

3-phase, 5-wire, 400 V -10/+15%, 50 Hz, 10 AT

GOLD 040, capacity variant 1:

3-phase, 5-wire, 400 V -10/+15%, 50 Hz, 16 AT

GOLD 040, capacity variant 2:

3-phase, 5-wire, 400 V -10/+15%, 50 Hz, 20 AT

GOLD 050, capacity variant 1:

3-phase, 5-wire, 400 V -10/+15%, 50 Hz, 16 AT

GOLD 050, capacity variant 2:

3-phase, 5-wire, 400 V -10/+15%, 50 Hz, 20 AT

GOLD 060, capacity variant 1:

3-phase, 5-wire, 400 V -10/+15%, 50 Hz, 16 AT

GOLD 060, capacity variant 2:

3-phase, 5-wire, 400 V -10/+15%, 50 Hz, 25 AT

GOLD 070, capacity variant 1:

3-phase, 5-wire, 400 V -10/+15%, 50 Hz, 16 AT

GOLD 070, capacity variant 2:

3-phase, 5-wire, 400 V -10/+15%, 50 Hz, 25 AT

GOLD 080, capacity variant 1:

3-phase, 5-wire, 400 V -10/+15%, 50 Hz, 25 AT

GOLD 080, capacity variant 2:

3-phase, 5-wire, 400 V -10/+15%, 50 Hz, 40 AT

GOLD 100, capacity variant 1:

3-phase, 5-wire, 400 V -10/+15%, 50 Hz, 25 AT

GOLD 100, capacity variant 2:

3-phase, 5-wire, 400 V -10/+15%, 50 Hz, 40 AT

GOLD 120, capacity variant 1:

3-phase, 5-wire, 400 V -10/+15%, 50 Hz, 40 AT

GOLD 120, capacity variant 2:

3-phase, 5-wire, 400 V -10/+15%, 50 Hz, 63 AT

6.3.2 Fans

RATED DATA PER FAN

GOLD 004: Motor shaft power: 1.15 kW (0.41 kW)*,
motor controller: 1 x 230 V, 50 Hz

GOLD 005: Motor shaft power: 1.15 kW (0.8 kW)*,
motor control system, 1 x 230 V, 50 Hz
or Motor shaft power: 1.15 kW,
motor controller: 1 x 230 V, 50 Hz

GOLD 007: Motor shaft power: 1.15 kW (0.8 kW)*,
motor control system, 1 x 230 V, 50 Hz
or Motor shaft power: 1.15 kW,
motor controller: 1 x 230 V, 50 Hz

GOLD 008: Motor shaft power: 1.15 kW,
motor control system, 1 x 230 V, 50 Hz
or Motor shaft power: 1.6 kW,
3 x 400 V, 50 Hz

GOLD 011: Motor shaft power: 1.15 kW,
motor control system, 1 x 230 V, 50 Hz
or Motor shaft power: 1.6 kW,
3 x 400 V, 50 Hz

GOLD 012: Motor shaft power: 2.4 kW (1.6 kW)*,
motor control system, 3 x 400 V, 50 Hz
or Motor shaft power: 2.4 kW,
motor control system, 3 x 400 V, 50 Hz

GOLD 014: Motor shaft power: 2.4 kW (1.6 kW)*,
motor control system, 3 x 400 V, 50 Hz
or Motor shaft power: 2.4 kW,
motor control system, 3 x 400 V, 50 Hz

GOLD 020: Motor shaft power: 2.4 kW,
motor control system, 3 x 400 V, 50 Hz
or Motor shaft power: 3.4 kW,
motor control system, 3 x 400 V, 50 Hz

GOLD 025: Motor shaft power: 2.4 kW,
motor control system, 3 x 400 V, 50 Hz
or Motor shaft power: 3.4 kW,
motor control system, 3 x 400 V, 50 Hz

GOLD 030: Motor shaft power: 4.0 kW,
motor control system, 3 x 400 V, 50 Hz
or Motor shaft power: 5.0 kW,
motor control system, 3 x 400 V, 50 Hz

GOLD 035: Motor shaft power: 4.0 kW,
motor control system, 3 x 400 V, 50 Hz
or Motor shaft power: 5.0 kW,
motor control system, 3 x 400 V, 50 Hz

GOLD 040: Motor shaft power: 6.5 kW,
motor control system, 3 x 400 V, 50 Hz
or Motor shaft power: 10 kW,
motor control system, 3 x 400 V, 50 Hz

GOLD 050: Motor shaft power: 6.5 kW,
motor control system, 3 x 400 V, 50 Hz
or Motor shaft power: 10 kW,
motor control system, 3 x 400 V, 50 Hz

GOLD 060: Motor shaft power: 2 x 4.0 kW,
motor control system, 3 x 400 V, 50 Hz
or Motor shaft power: 2 x 6.5 kW,
motor control system, 3 x 400 V, 50 Hz

GOLD 070: Motor shaft power: 2 x 4.0 kW,
motor control system, 3 x 400 V, 50 Hz
or Motor shaft power: 2 x 6.5 kW,
motor control system, 3 x 400 V, 50 Hz

GOLD 080: Motor shaft power: 2 x 6.5 kW,
motor control system, 3 x 400 V, 50 Hz
or Motor shaft power: 2 x 10 kW,
motor control system, 3 x 400 V, 50 Hz

GOLD 100: Motor shaft power: 2 x 6.5 kW,
motor control system, 3 x 400 V, 50 Hz
or Motor shaft power: 2 x 10 kW,
motor control system, 3 x 400 V, 50 Hz

GOLD 120: Motor shaft power: 3 x 6.5 kW,
motor control system, 3 x 400 V, 50 Hz
or Motor shaft power: 3 x 10 kW,
motor control system, 3 x 400 V, 50 Hz

*) The motor controller limits the output power to the value specified.

6.3.3 Electrical Equipment Cubicle

The fuse protection of the air handling unit must not exceed the value stated in Section 6.3.1.

SAFETY ISOLATING SWITCH

Capacity variant 1

GOLD SD 004-011: 20 A

GOLD SD 012-100: 25 A

GOLD SD 120: 63 A

Capacity variant 2

GOLD SD 005-007: 20 A

GOLD SD 008-035: 25 A

GOLD SD 040-070: 32 A

GOLD SD 080-100: 63 A

GOLD SD 120: 80 A

FUSES IN THE ELECTRICAL EQUIPMENT CUBICLE

230 V control current

All the sizes/variants:

One 2-pole, 6A automatic circuit breaker

Fans

GOLD 004-007, GOLD 008, cap.-var. 1,

GOLD 011 cap.-var. 1

SD One 2-pole, 10A automatic circuit breaker

GOLD 008, cap.-var. 2, GOLD 011, cap.-var. 2, GOLD 012-014, GOLD 020, cap.-var. 1:

SD One 6.3A protective motor switch

GOLD 020 cap.-var. 2:

SD One 7.0A protective motor switch

GOLD 025, GOLD 030 cap.-var. 1, GOLD 035 cap.-var. 1:

SD One 10A protective motor switch

GOLD 030 cap.-var. 2, GOLD 035 cap.-var. 2:

SD One 10.6A protective motor switch

GOLD 040 cap.-var. 1, GOLD 050 cap.-var. 1:

SD One 13.2A protective motor switch

GOLD 040 cap.-var. 2, GOLD 050 cap.-var. 2:

SD One 18A protective motor switch

GOLD 060 cap.-var. 1, GOLD 070 cap.-var. 1:

SD Two 10A protective motor switches

GOLD 060 cap.-var. 2, GOLD 070 cap.-var. 2, GOLD 080 cap.-var. 1, GOLD 100 cap.-var. 1:

SD Two 13.2A protective motor switches

GOLD 080 cap.-var. 2, GOLD 100 cap.-var. 2:

SD Two 18A protective motor switches

GOLD 120 cap.-var. 1:

SD Three 13.2A protective motor switches

GOLD 120 cap.-var. 2:

SD Three 18A protective motor switches

FUSES IN THE CONTROL UNIT

3.15 AT, incoming 230V. For mounting, see Section 6.2. For replacement, dismantle the control unit's plastic enclosure.

6.3.4 Control Inaccuracy:

Temperature $\pm 1^\circ\text{C}$.

Airflow $\pm 5\%$.

6.3.5 EMC

The air handling unit with the power supply 3-phase 400 V conforms to IEC 61000-3-12 provided that the short-circuit power S_{sc} is greater than or equal to the value in the table below for each size/capacity variant.

It is the duty of the installer or user of the equipment to ensure, through consultation with the distribution network operator if necessary, that the equipment is only connected to a supply with the correct short-circuit power S_{sc} for each unit.

| GOLD SD, size - capacity variant | Short-circuit power S_{sc} MVA |
|-------------------------------------|----------------------------------|
| 008-2 | 0,4 |
| 011-2 | 0,4 |
| 012-1 | 0,4 |
| 012-2 | 0,6 |
| 014-1 | 0,4 |
| 014-2 | 0,6 |
| 020-1 | 0,7 |
| 020-2 | 0,8 |
| 025-1 | 0,7 |
| 025-2 | 0,8 |
| 030-1 | 1,0 |
| 030-2 | 1,4 |
| 035-1 | 1,0 |
| 035-2 | 1,4 |
| 040-1 | 1,7 |
| 040-2 | 2,8 |
| 050-1 | 1,7 |
| 050-2 | 2,8 |
| 060-1 | 2,0 |
| 060-2 | 3,2 |
| 070-1 | 2,0 |
| 070-2 | 3,2 |
| 080-1 | 3,3 |
| 080-2 | 5,6 |
| 100-1 | 3,3 |
| 100-2 | 5,6 |
| 120-1 | 4,9 |
| 120-2 | 8,4 |

6.4 Volume of Glycol/Water in Coil Heat Exchangers, SD

Total volume of the coils (excl. pipework package and piping):

| | |
|------------------|------------|
| SD, size 004/005 | 34 litres |
| SD, size 007/008 | 48 litres |
| SD, size 011/012 | 70 litres |
| SD, size 014/020 | 106 litres |
| SD, size 025/030 | 138 litres |
| SD, size 035/040 | 218 litres |
| SD, size 050/060 | 262 litres |
| SD, size 070/080 | 336 litres |
| SD, size 100/120 | 538 litres |

7. Appendices

7.1 Declaration of Conformity

For Declaration of Conformity, see our home page at www.swegon.com.

7.2 Building Materials Declaration

For a complete Declaration of Construction Materials, see our home page at www.swegon.com.

7.3 License

Copyright 2013-2014 Swegon AB

All right reserved.

Parts of this work are subject to GNU General Public License v2.0 and other Free/Libre Open Source Software licenses.

This program is free software: You can redistribute it and/or modify it under the terms of the GNU General Public License as published by the Free Software Foundation, either version 3 of the License, or (at your option) any later version.

This program is distributed in the hope that it will be useful, but WITHOUT ANY WARRANTY; without even the implied warranty of MERCHANTABILITY or FITNESS FOR A PARTICULAR PURPOSE. See the GNU General Public License for more details.

You should have received a copy of the GNU General Public License along with this program. If not, see <http://www.gnu.org/licenses/>.

For full licensing conditions and the Free/Libre Open Source Software components, please visit:
<http://ftp.swegon.se/opensource/opensource/>

7.4 Ecodesign data

The air handling unit complies with the directives 2009/125/EC and 2014/53/EU.

Data for directive 2014/53/EU is available for sizing in the product selection software AHU Design.

Data for directive 327/2011/EU according to below.

Air Handling Units, EU regulation 327/2011 all fan data

Datum: 2024-02-15

| Type | AHU data | | | Fan data | | | | Data according to ErP directive in technical documentation and free access webpage | | | | | | | | | | | |
|-------------------------------|----------|--------------|----------------|---------------|-------------------------|-------------------|-------------------|--|---------------------|----------------------|----------------|--------------------------|----------|--------------------|----------|-----------------------|---------------------|-----------------------------|------------------------------|
| | Size | Motor option | Number of fans | Impeller type | Impeller diameter mm | Motor manufacture | Motor power kW | Installation category | Efficiency category | Variable speed drive | Specific ratio | Overall efficiency ηe(s) | | Efficiency grade N | | Power input Ped kW | Air Flow qv m³/s | Pressure increase pfs Pa | Speed n min ⁻¹ |
| | | | | | | | | | | | | Actual | Req 2015 | Actual | Req 2015 | | | | |
| GOLD SILVER C Version F | 004 | - | 1 | Aluminium | 288 | Domel ZKG | 0,41 | A | Static | Yes | 1,01 | 65,9 | 48,0 | 79,9 | 62 | 0,463 | 0,514 | 534 | 2700 |
| | 005 | 1 | 1 | Aluminium | 288 | Domel ZKG | 0,8 | A | Static | Yes | 1,01 | 65,3 | 50,8 | 76,5 | 62 | 0,862 | 0,728 | 708 | 3380 |
| | 005 | 2 | 1 | Aluminium | 288 | Domel ZKG | 1,15 | A | Static | Yes | 1,01 | 65,2 | 52,0 | 75,1 | 62 | 1,126 | 0,806 | 840 | 3700 |
| | 007 | 1 | 1 | Aluminium | 288 | Domel ZKG | 0,8 | A | Static | Yes | 1,01 | 65,3 | 50,8 | 76,5 | 62 | 0,862 | 0,728 | 708 | 3380 |
| | 007 | 2 | 1 | Aluminium | 288 | Domel ZKG | 1,15 | A | Static | Yes | 1,01 | 65,2 | 52,0 | 75,1 | 62 | 1,126 | 0,806 | 840 | 3700 |
| | 008 | 1 | 1 | Aluminium | 348 | Domel ZKG | 1,15 | A | Static | Yes | 1,01 | 66,3 | 52,5 | 75,7 | 62 | 1,26 | 0,928 | 831 | 2780 |
| | 008 | 2 | 1 | Aluminium | 348 | Domel ZKG | 1,6 | A | Static | Yes | 1,01 | 68,9 | 53,6 | 77,3 | 62 | 1,60 | 1,02 | 1003 | 3050 |
| | 011 | 1 | 1 | Aluminium | 348 | Domel ZKG | 1,15 | A | Static | Yes | 1,01 | 66,3 | 52,5 | 75,7 | 62 | 1,26 | 0,928 | 831 | 2780 |
| | 011 | 2 | 1 | Aluminium | 348 | Domel ZKG | 1,6 | A | Static | Yes | 1,01 | 68,9 | 53,6 | 77,3 | 62 | 1,60 | 1,02 | 1003 | 3050 |
| | 012 | 1 | 1 | Aluminium | 422 | Domel ZKG | 1,6 | A | Static | Yes | 1,01 | 67,5 | 53,9 | 75,6 | 62 | 1,68 | 1,34 | 790 | 2250 |
| | 012 | 2 | 1 | Aluminium | 422 | Domel ZKG | 2,4 | A | Static | Yes | 1,01 | 67,3 | 55,3 | 74,0 | 62 | 2,30 | 1,48 | 982 | 2500 |
| | 014 | 1 | 1 | Aluminium | 422 | Domel ZKG | 1,6 | A | Static | Yes | 1,01 | 67,5 | 53,9 | 75,6 | 62 | 1,68 | 1,34 | 790 | 2250 |
| | 014 | 2 | 1 | Aluminium | 422 | Domel ZKG | 2,4 | A | Static | Yes | 1,01 | 67,3 | 55,3 | 74,0 | 62 | 2,30 | 1,48 | 982 | 2500 |
| | 020 | 1 | 1 | Aluminium | 510 | Domel ZKG | 2,4 | A | Static | Yes | 1,01 | 67,3 | 55,9 | 73,4 | 62 | 2,62 | 2,01 | 827 | 1890 |
| | 020 | 2 | 1 | Aluminium | 510 | Domel ZKG | 3,4 | A | Static | Yes | 1,01 | 67,0 | 57,3 | 71,7 | 62 | 3,56 | 2,25 | 1011 | 2100 |
| | 025 | 1 | 1 | Aluminium | 510 | Domel ZKG | 2,4 | A | Static | Yes | 1,01 | 67,3 | 55,9 | 73,4 | 62 | 2,62 | 2,01 | 827 | 1890 |
| | 025 | 2 | 1 | Aluminium | 510 | Domel ZKG | 3,4 | A | Static | Yes | 1,01 | 67,0 | 57,3 | 71,7 | 62 | 3,56 | 2,25 | 1011 | 2100 |
| | 030 | 1 | 1 | Aluminium | 616 | Domel ZKG | 4 | A | Static | Yes | 1,01 | 68,7 | 58,0 | 72,6 | 62 | 4,20 | 3,06 | 901 | 1635 |
| | 035 | 1 | 1 | Aluminium | 616 | Domel ZKG | 4 | A | Static | Yes | 1,01 | 68,7 | 58,0 | 72,6 | 62 | 4,20 | 3,06 | 901 | 1635 |
| | 060 | 1 | 2 | Aluminium | 616 | Domel ZKG | 4 | A | Static | Yes | 1,01 | 68,7 | 58,0 | 72,6 | 62 | 4,20 | 3,06 | 901 | 1635 |
| | 070 | 1 | 2 | Aluminium | 616 | Domel ZKG | 4 | A | Static | Yes | 1,01 | 68,7 | 58,0 | 72,6 | 62 | 4,20 | 3,06 | 901 | 1635 |
| | 030 | 2 | 1 | Aluminium | 616 | Domel ZKG | 5 | A | Static | Yes | 1,01 | 67,7 | 58,9 | 70,8 | 62 | 5,10 | 3,23 | 1028 | 1740 |
| | 035 | 2 | 1 | Aluminium | 616 | Domel ZKG | 5 | A | Static | Yes | 1,01 | 67,7 | 58,9 | 70,8 | 62 | 5,10 | 3,23 | 1028 | 1740 |
| | 060 | 2 | 2 | Aluminium | 616 | Domel ZKG | 6,5 | A | Static | Yes | 1,01 | 68,2 | 60,2 | 70,1 | 62 | 6,67 | 3,58 | 1220 | 1900 |
| | 070 | 2 | 2 | Aluminium | 616 | Domel ZKG | 6,5 | A | Static | Yes | 1,01 | 68,2 | 60,2 | 70,1 | 62 | 6,67 | 3,58 | 1220 | 1900 |
| | 040 | 1 | 1 | Aluminium | 744 | Domel ZKG | 6,5 | A | Static | Yes | 1,01 | 66,4 | 60,2 | 68,2 | 62 | 6,67 | 4,65 | 915 | 1380 |
| | 050 | 1 | 1 | Aluminium | 744 | Domel ZKG | 6,5 | A | Static | Yes | 1,01 | 66,4 | 60,2 | 68,2 | 62 | 6,67 | 4,65 | 915 | 1380 |
| | 080 | 1 | 2 | Aluminium | 744 | Domel ZKG | 6,5 | A | Static | Yes | 1,01 | 66,4 | 60,2 | 68,2 | 62 | 6,67 | 4,65 | 915 | 1380 |
| | 100 | 1 | 2 | Aluminium | 744 | Domel ZKG | 6,5 | A | Static | Yes | 1,01 | 66,4 | 60,2 | 68,2 | 62 | 6,67 | 4,65 | 915 | 1380 |
| | 120 | 1 | 3 | Aluminium | 744 | Domel ZKG | 6,5 | A | Static | Yes | 1,01 | 66,4 | 60,2 | 68,2 | 62 | 6,67 | 4,65 | 915 | 1380 |
| | 040 | 2 | 1 | Aluminium | 744 | Domel ZKG | 9 | A | Static | Yes | 1,01 | 66,8 | 61,9 | 66,9 | 62 | 9,71 | 5,30 | 1176 | 1560 |
| | 050 | 2 | 1 | Aluminium | 744 | Domel ZKG | 9 | A | Static | Yes | 1,01 | 66,8 | 61,9 | 66,9 | 62 | 9,71 | 5,30 | 1176 | 1560 |
| | 080 | 2 | 2 | Aluminium | 744 | Domel ZKG | 9 | A | Static | Yes | 1,01 | 66,8 | 61,9 | 66,9 | 62 | 9,71 | 5,30 | 1176 | 1560 |
| 100 | 2 | 2 | Aluminium | 744 | Domel ZKG | 9 | A | Static | Yes | 1,01 | 66,8 | 61,9 | 66,9 | 62 | 9,71 | 5,30 | 1176 | 1560 | |
| 120 | 2 | 3 | Aluminium | 744 | Domel ZKG | 9 | A | Static | Yes | 1,01 | 66,8 | 61,9 | 66,9 | 62 | 9,71 | 5,30 | 1176 | 1560 | |

7.5 Digital Services

Connectivity

The product is equipped with functionality that, when enabled, will connect to the Swegon INSIDE Cloud when given access to the internet. Such connection is made either through the building's local internet access point or by using a supplied modem. When connecting through the building's internet access point, the local firewall must be configured to allow traffic according to the firewall settings. The functionality is by default disabled and can be enabled in the product. By enabling this functionality the customer agrees to the general terms and conditions for Digital Service, DS-23. The customer can disable the connection to the Swegon INSIDE Cloud in the product user interface at any time.

Which data is sent

Through the connection to Swegon INSIDE Cloud, the product will exchange data to Swegon INSIDE Cloud about certain actions and parameter settings of the product. Each data point has different thresholds for when to send data to Swegon, therefore the data sent depends on the data point type and configuration. The data is sent in intervals, at which point the data is aggregated together with other data from that interval.

Who has access to the data

The data sent to Swegon INSIDE Cloud is used by Swegon for purposes of performance, functionality and development of the product. Consequently, Swegon has the right to use the data sent from all products connected to Swegon INSIDE Cloud. The data is used in accordance with Swegon's DS-23 general terms and conditions, and our sales agreement with the customer.

Requirements

To connect a product to Swegon INSIDE Cloud, a secure internet connection via the property's internal network or via Swegon's external modem is required. In addition to a secure internet connection, a valid certificate for each individual product is also required to approve them to share data with INSIDE Cloud. Some products will come with a valid certificate out of the factory, while other products need to be equipped with a certificate to authorize the product to share data.

To find out if the product is INSIDE Ready (i.e. ready to share data) or not visit INSIDE Ready | www.swegon.com.

All documentation is available in digital form and can be downloaded from
www.swegon.com