

SILVER

Air Handling Unit

Installation instructions

SILVER RX/CX version G, size 100/120

The document was originally written in Swedish.

Contents

1. Installation.....	3
1.1 General.....	3
1.2 Transport within the site.....	3
1.3 Parts packed together with the unit.....	3
1.3.1 Document pocket.....	3
1.4 Arrangement.....	3
1.5 Method of delivery.....	3
1.5.1 SILVER RX.....	3
1.5.2 SILVERX.....	3
1.6 Lifting.....	4
1.6.1 With a fork-lift truck.....	4
1.6.2 With a crane.....	4
1.6.2.1 Complete units.....	4
1.6.2.2 Heat exchanger section, supplied split into two casing sections and rotor (SILVER RX only).....	5
1.7 To assemble the heat exchanger unit section, if required (SILVER RX only).....	7
1.7.1 Alternative 1.....	7
1.7.2 Alternative 2.....	11
1.7.3 Common for Alternatives 1 and 2.....	15
1.7.3.1 To adjust the rotor's inclination.....	15
1.7.3.2 Sealing plates/purging sector.....	16
1.7.3.3 Pressing roller.....	16
1.7.3.4 Vinyl-coated fabric seal.....	16
1.7.3.5 Sealing.....	17
1.8 Version and fan arrangement.....	18
1.8.1 SILVER RX.....	18
1.8.2 SILVERX.....	18
1.9 The docking of unit sections.....	19
1.9.1 Fan/filter/coil heat exchanger sections (Coil heat exchanger sections SILVERX only).....	19
1.9.2 Fastening, front/middle section.....	20
1.9.3 Fixation, rear of the unit.....	20
1.10 Duct connection.....	21
1.11 Electrical Connections.....	22
1.12 Installation of pipework package (SILVERX only).....	23
2. Dimensions.....	23
2.1 SILVER RX 100/120.....	23
2.2 SILVERX 100/120.....	24

1. Installation

1.1 General

All staff concerned must acquaint themselves with these instructions before beginning any work on the unit. Any damages to the unit or parts of it due to improper handling or misuse by the purchaser or the fitter cannot be considered subject to guarantee if these instructions have not been followed correctly.

The product identification label is affixed on the inspection side of the air handling unit. Refer to the particulars on the product identification plate when you contact Swegon.

The air handling unit is supplied in packaged condition.

Possible ordered accessories are supplied in separate packaging with the unit.

1.2 Transport within the site

Before removing the transport pallet/transport cradle, if used, determine whether a forklift truck or a pallet transporter will be used for further transporting the unit within the site to the spot where it will be installed.

1.3 Parts packed together with the unit

Components such as the commissioning plates, bolts and document pocket are supplied in separate packaging and delivered together with the air handling unit.

1.3.1 Document pocket

Secure the document pocket to the exterior of the air handling unit or another appropriate place.

1.4 Arrangement

The air handling unit must be mounted horizontally on a flat and firm supporting surface and this surface must be constructed in a way enabling it to support the weight of the unit.

When installing the air handling unit and connecting pipe-work and electric cables, make sure that adequate free space is provided for opening the inspection doors and covers and withdrawing functional sections, such as filter cassettes and fan assemblies, clear of the unit casing.

Inspection space required

A clear space of 1,000 mm should be provided in front of the unit for opening the inspection doors.

1.5 Method of delivery

1.5.1 SILVER RX

The SILVER RX 120 is normally supplied in five separate sections: Two fan sections, two filter sections and one heat exchanger section.

The heat exchanger section can also be supplied split into two casing sections and rotor, in which case the rotor is supplied tilted in a transport cradle (transport height = 2,930 mm, minimum transport width = 2,350 mm). See Section 1.7 for installation particulars.

For other dimensions and weights, see Section 2.1.

Heat exchanger section supplied as a separate unit

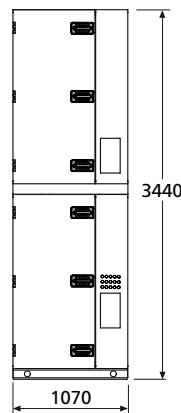

Heat exchanger section, supplied split into two casing sections and rotor

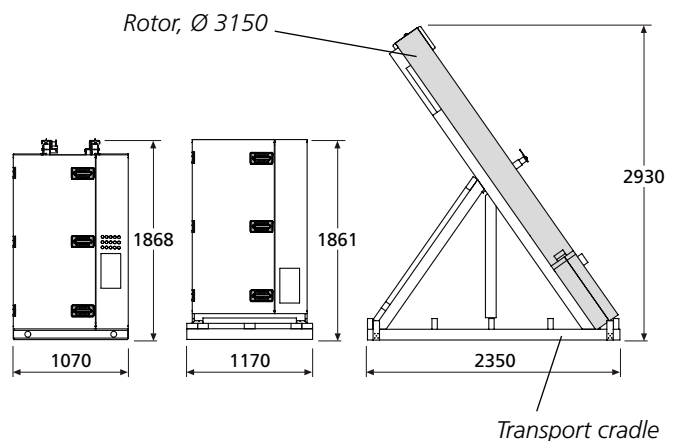

1.5.2 SILVERX

The SILVERX 120 is supplied in six separate sections: Two fan sections, two filter sections and two coil heat exchanger sections.

For dimensions and weights, see Section 2.2.

1.6 Lifting

1.6.1 With a fork-lift truck

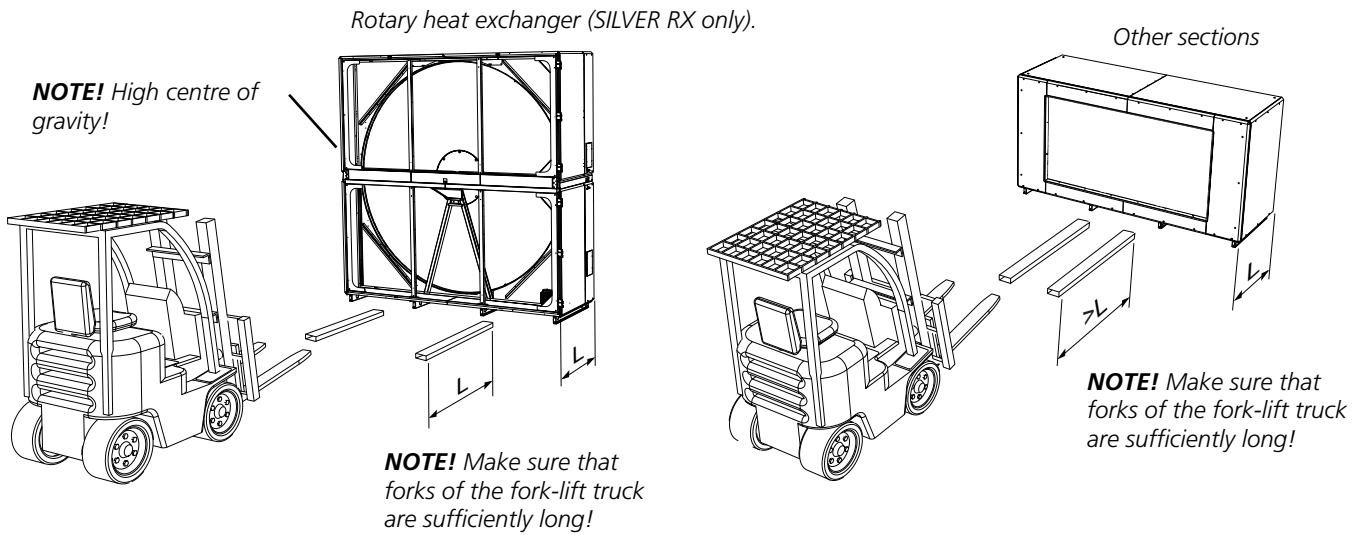

1.6.2 With a crane

1.6.2.1 Complete units

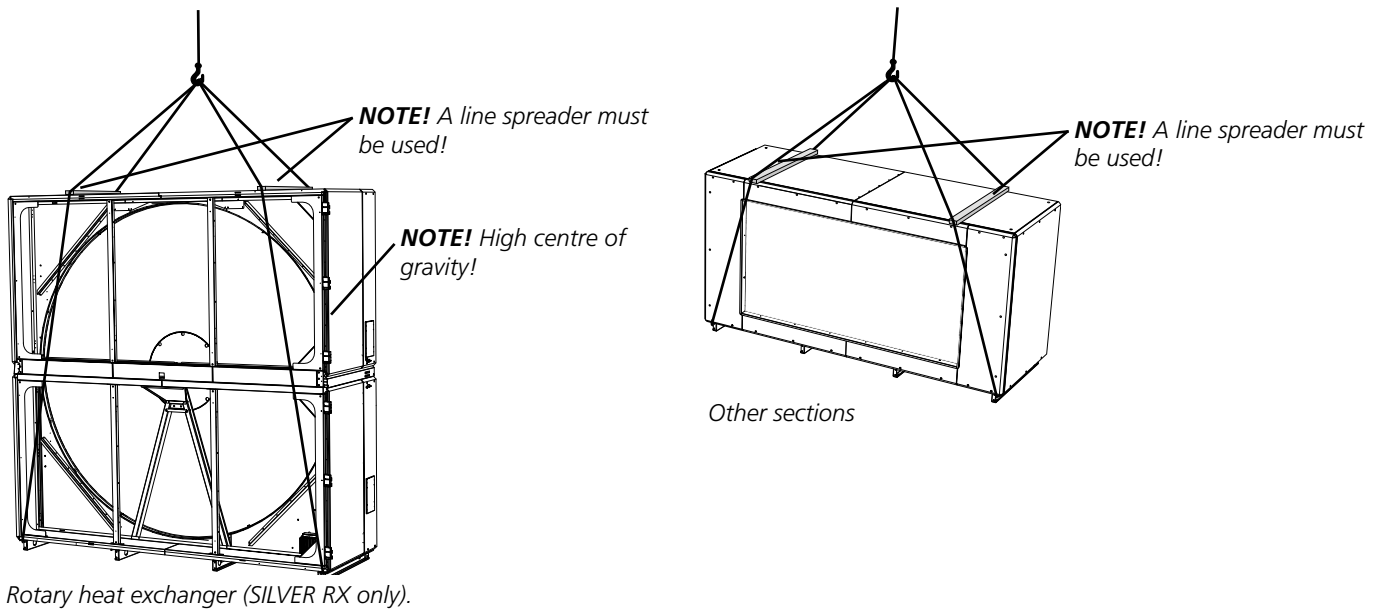

1.6.2.2 Heat exchanger section, supplied split into two casing sections and rotor (SILVER RX only)

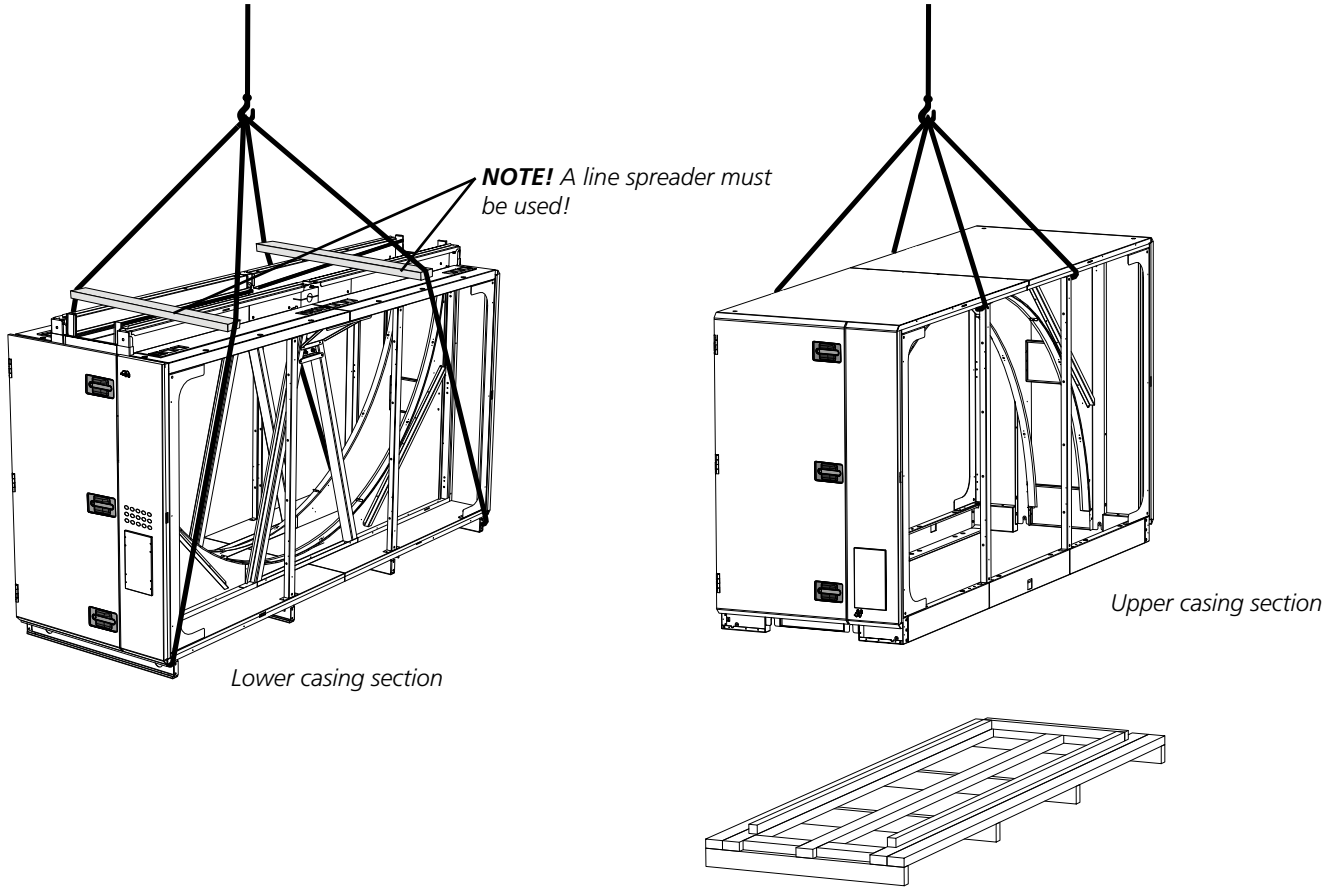

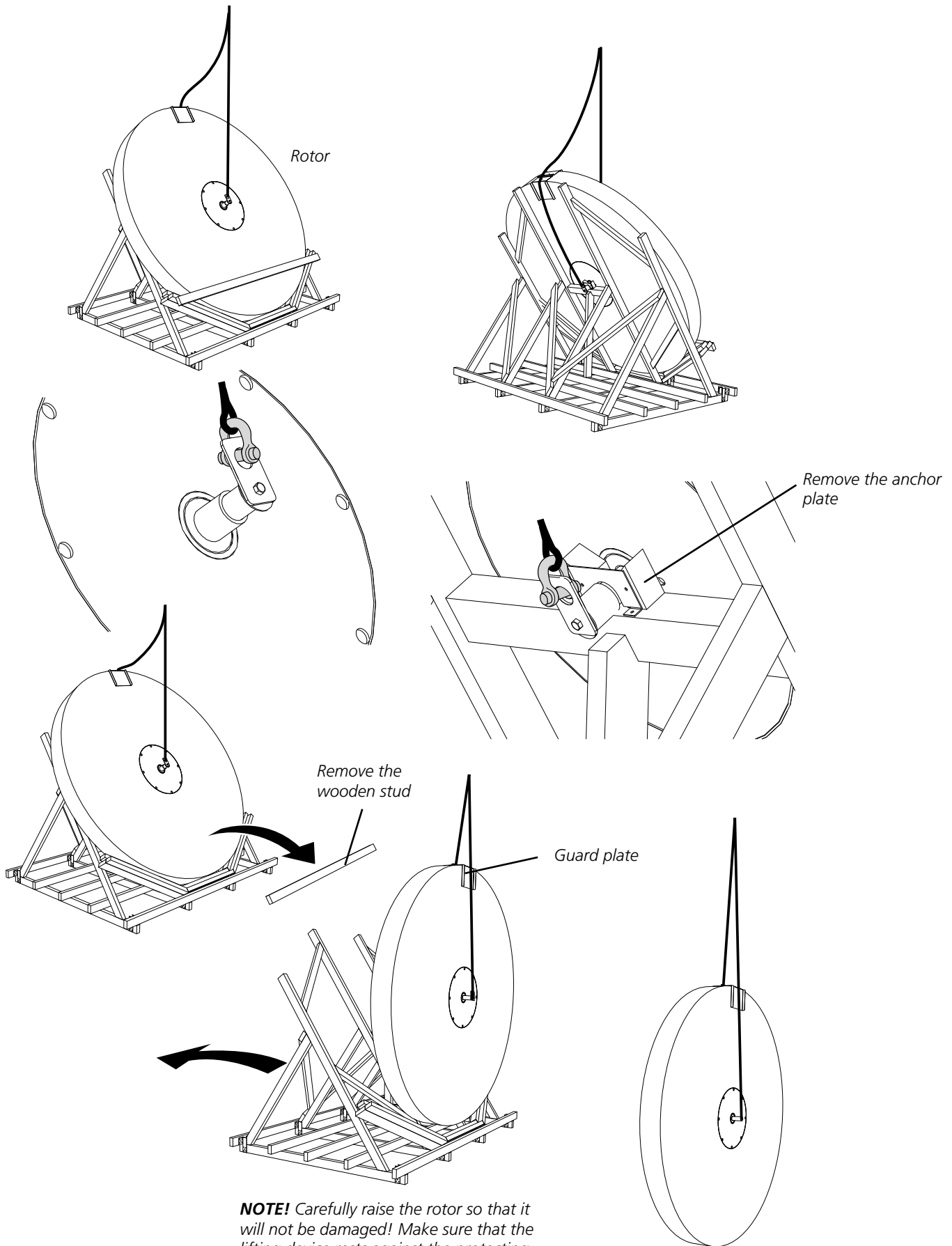

1.7 To assemble the heat exchanger unit section, if required (SILVER RX only)

If the heat exchanger unit section is supplied in parts, they must be jointed together. This can be done in two ways: Alternative 1 is appropriate for use if there is sufficient free space upward since this alternative is simpler. If sufficient space is not available, Alternative 2 should be used.

If the heat exchanger unit section is supplied as one unit, go on to Section 1.8.

1.7.1 Alternative 1

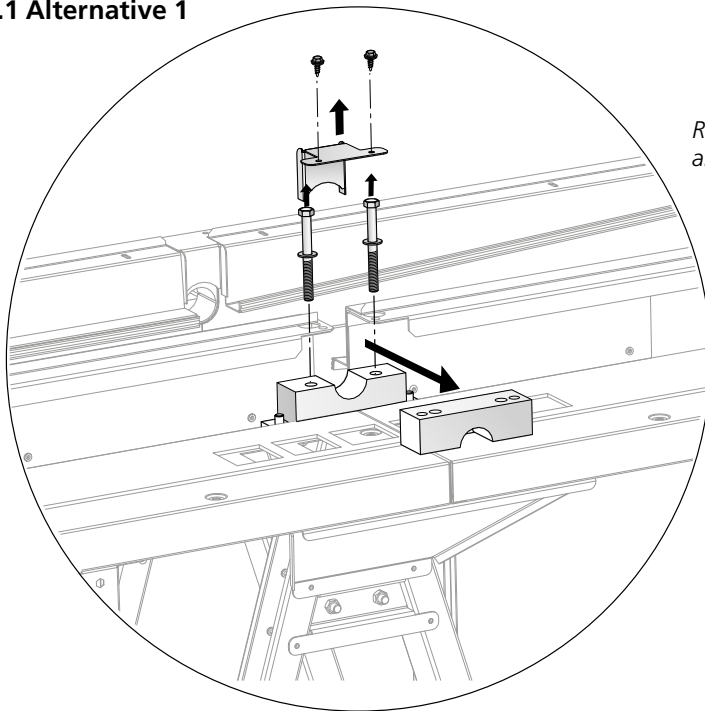

Remove the upper shaft bracket and the sealing plate (2x)

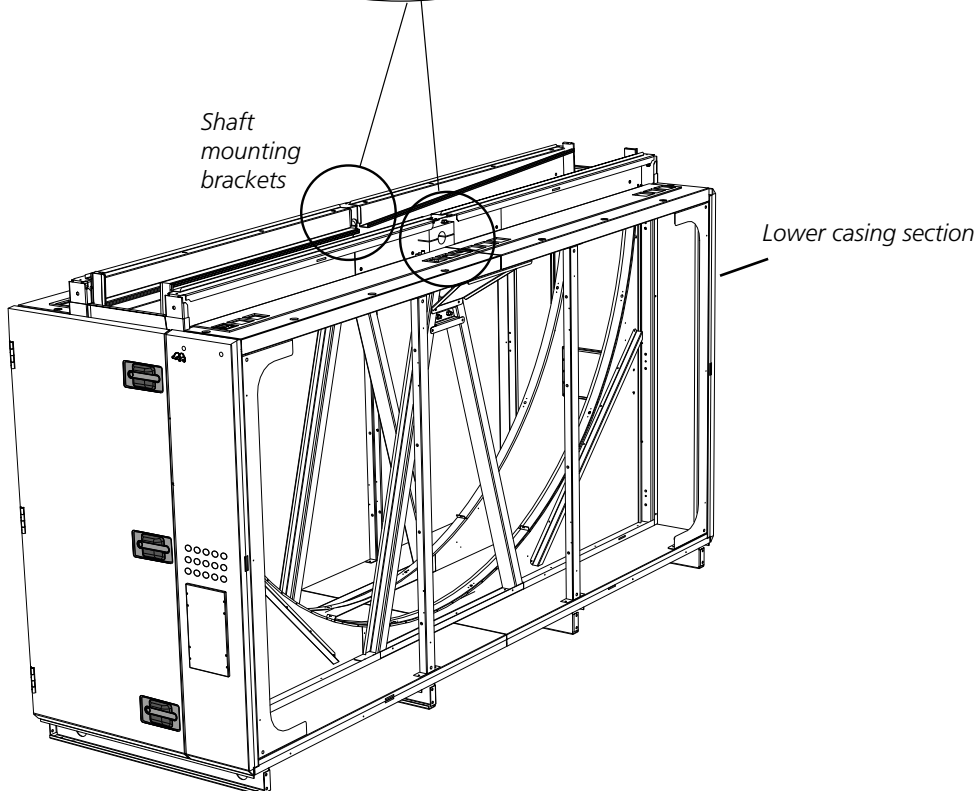

Shaft mounting brackets

Lower casing section

Lift the rotor into the lower casing section (see Section 1.6).

NOTE! IMPORTANT! The smooth side of the rotor hub (without holes) should face the pressing roller!
Be careful not to damage the rotor!

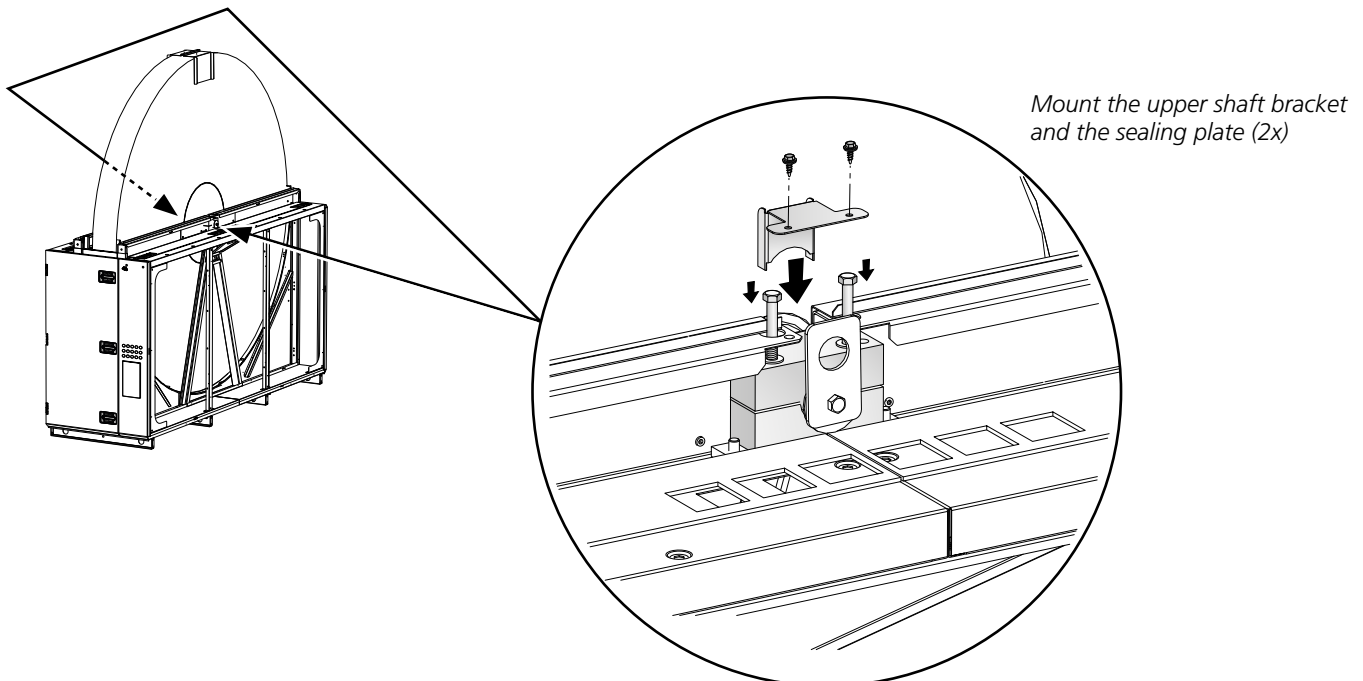
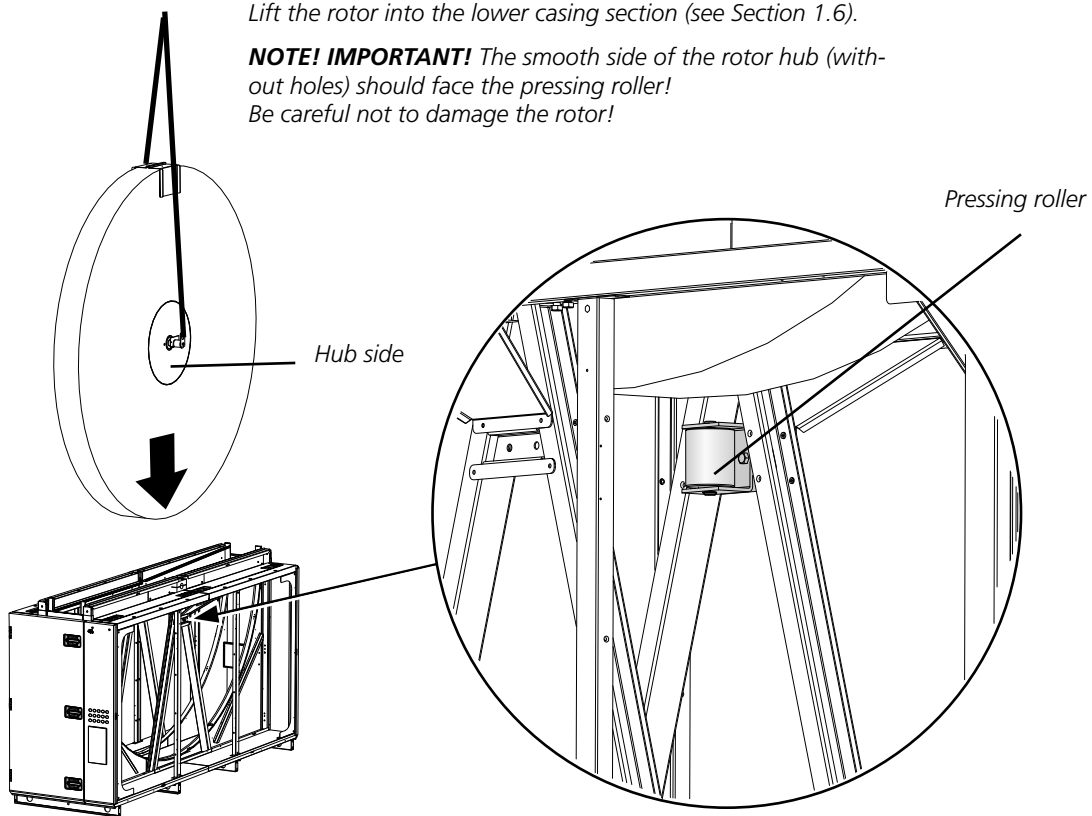

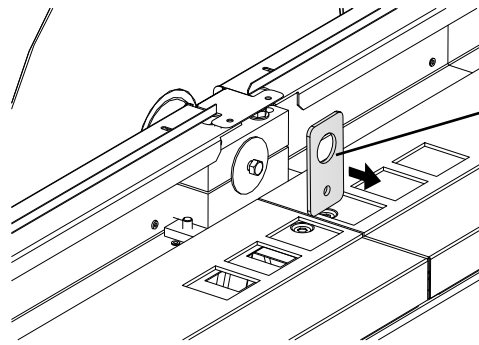

Remove the lifting lugs. Refit the bolts and washers to the shaft end (2x).



Remove the protecting plate of the rotor.

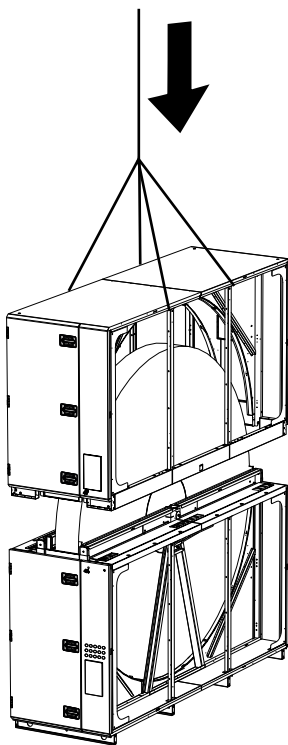

Lift the upper casing section onto the lower casing section (see Section 1.6).

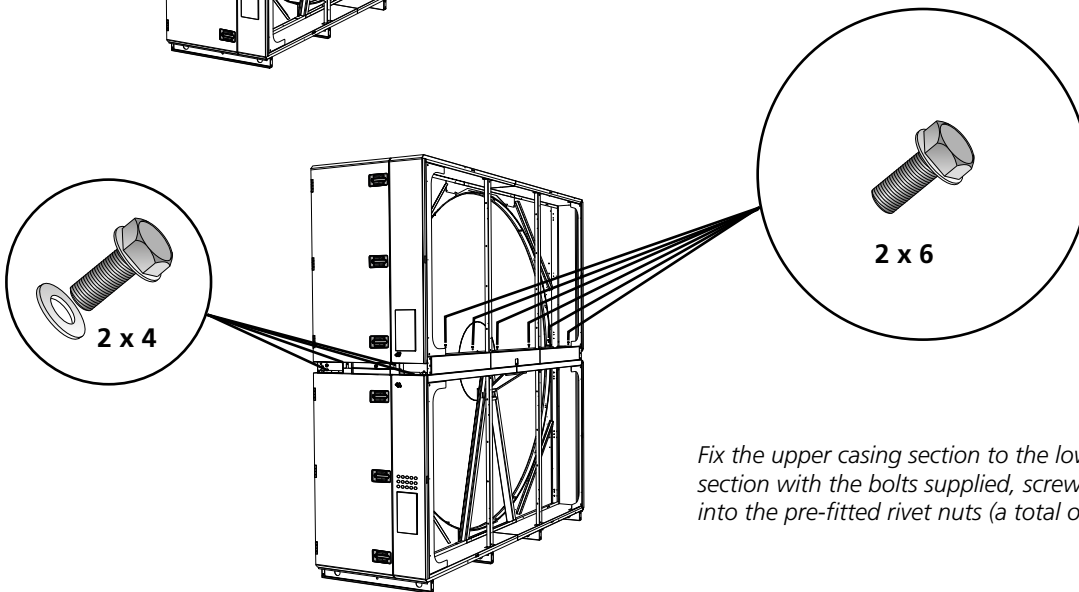
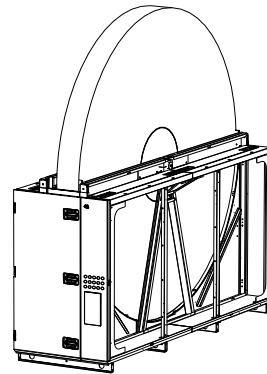

Fix the upper casing section to the lower casing section with the bolts supplied, screwing them into the pre-fitted rivet nuts (a total of 20 pcs.).

Dismantle the heat exchanger motor + mounting bracket (6 bolts). Move the motor + mounting bracket into position shown in the illustration and temporarily secure them with two screws. Place the rotor drive belt around the motor belt pulley.

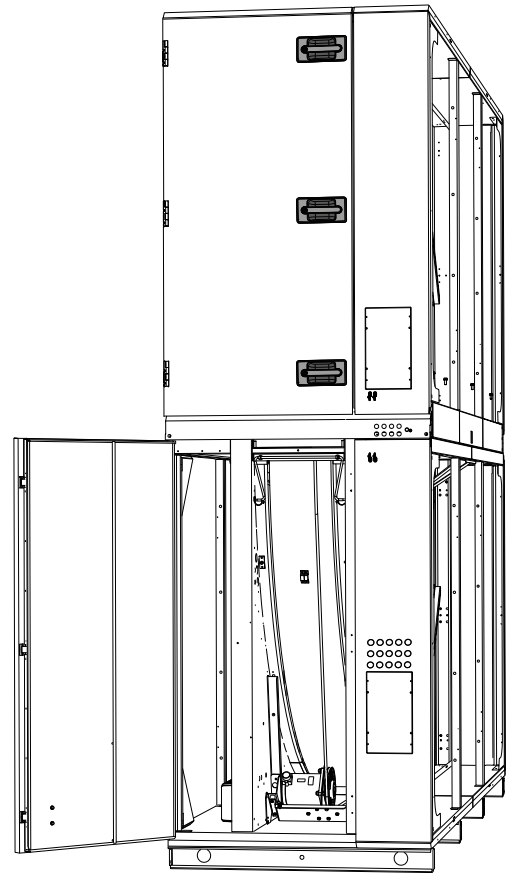
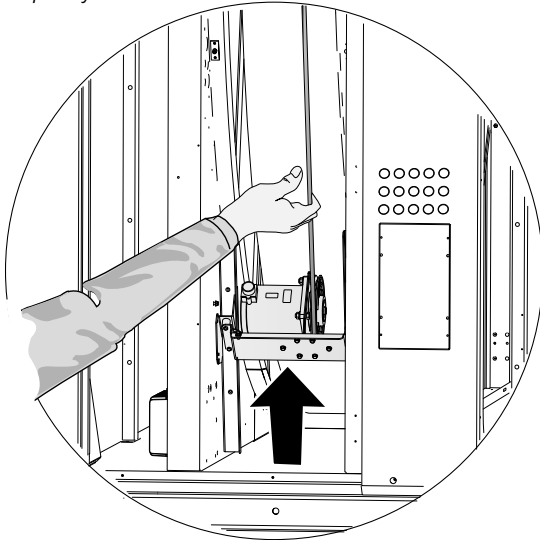

Slacken off the two screws holding the motor + mounting bracket. Move the motor + mounting bracket back to their original positions. Secure the motor + mounting bracket with bolts (6 bolts).

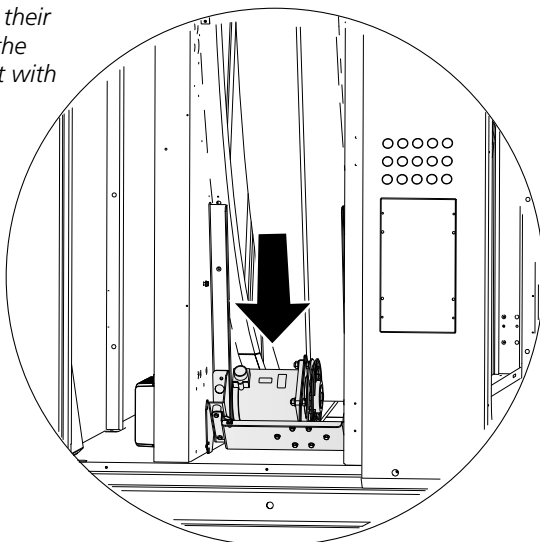

See also Section 1.7.3 Common for Alternatives 1 and 2

1.7.2 Alternative 2

Remove the upper shaft bracket
and the sealing plate (2x)

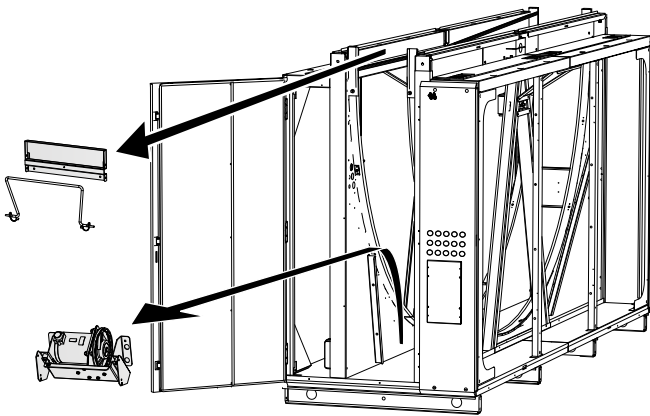
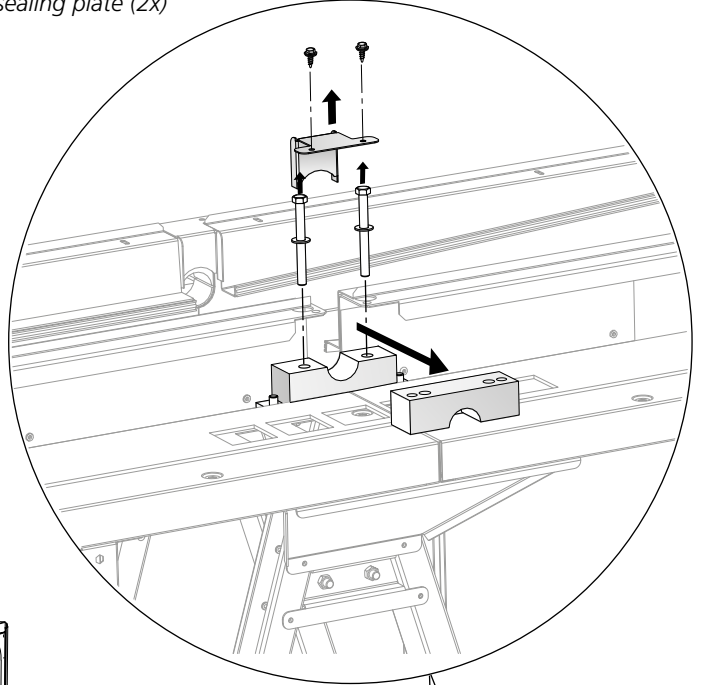

Dismantle the heat exchanger motor + mounting bracket
(6 bolts). Remove the sealing plate and tube.

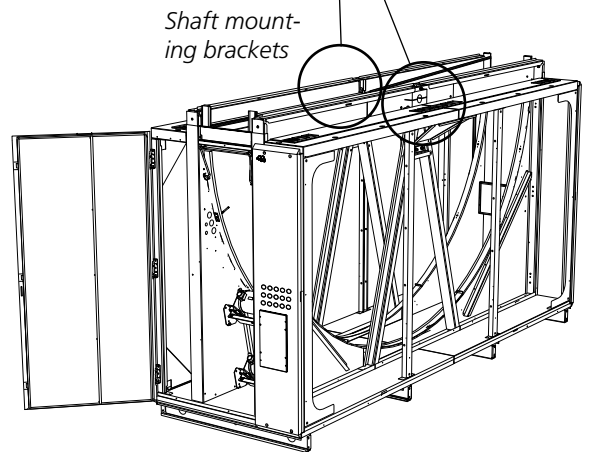

SILVER

Lift the rotor from the side into the lower casing section (see Section 1.6).

NOTE! IMPORTANT! The smooth side of the rotor hub (without holes) should face the pressing roller!
Be careful not to damage the rotor!

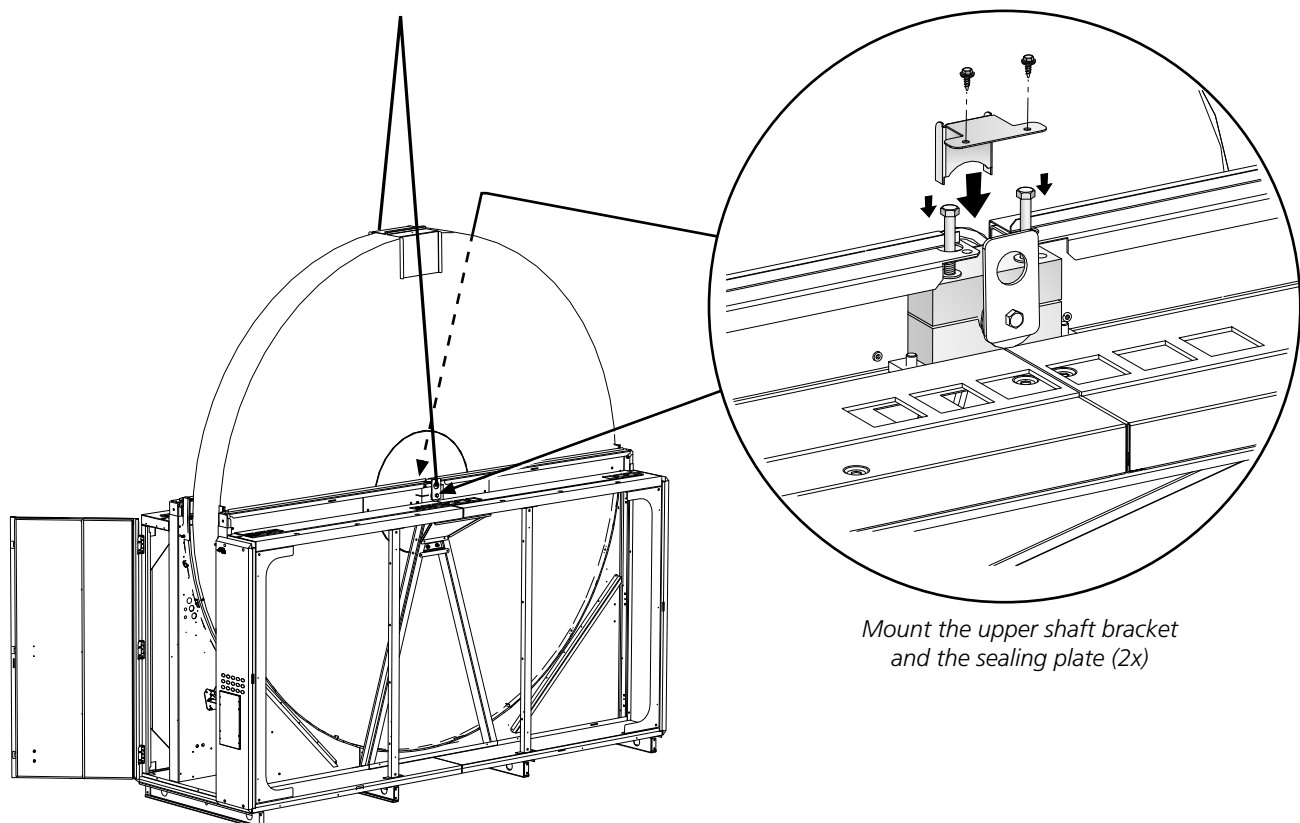
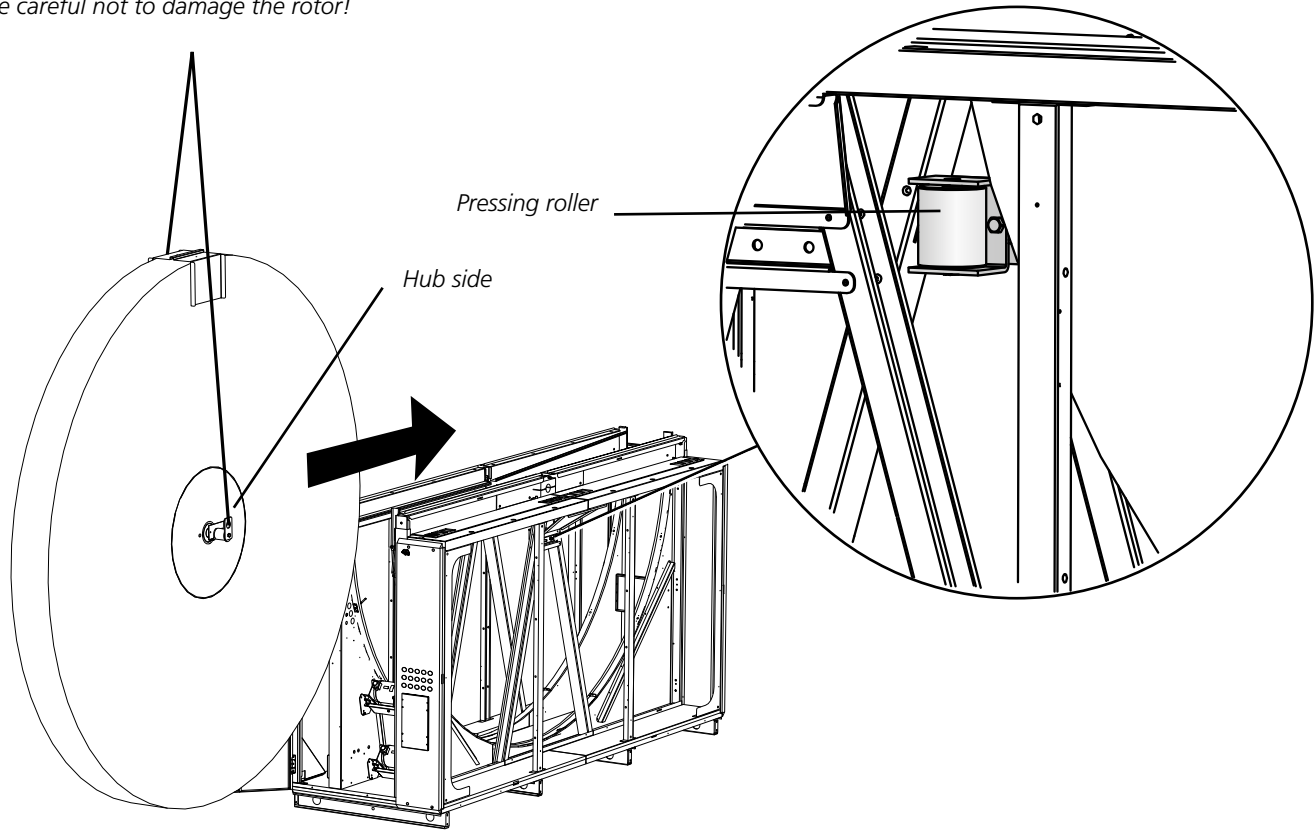

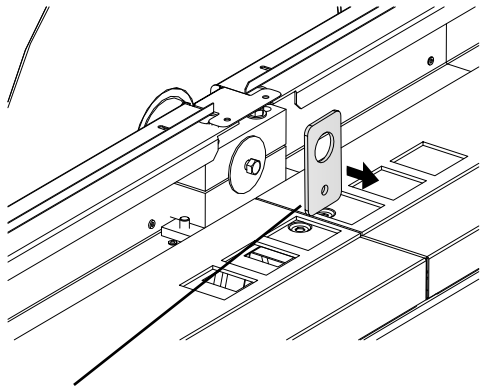

Remove the lifting lugs. Refit the bolts and washers to the shaft end (2x).

Remove the protecting plate of the rotor.

Fit the sealing plate and tube.

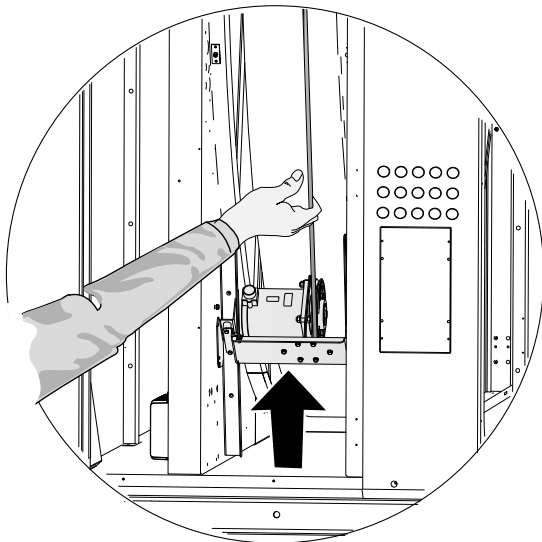
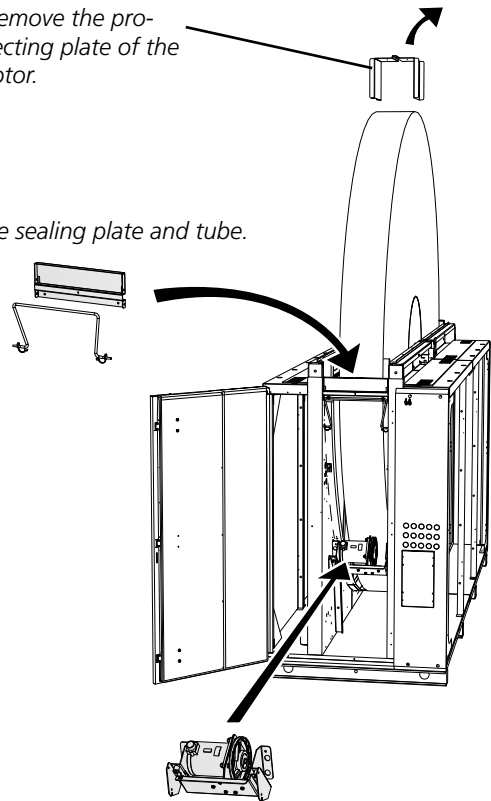

Move the motor + mounting bracket into position shown in the illustration and temporarily secure them with two screws. Place the rotor drive belt around the motor belt pulley.

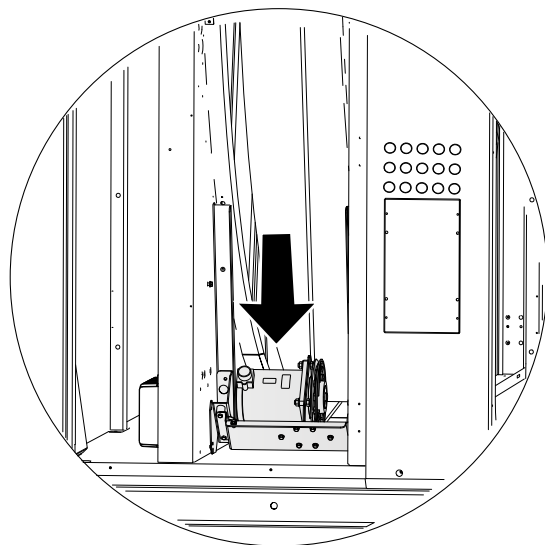

Slacken off the two screws holding the motor + mounting bracket. Move the motor + mounting bracket to the position shown in the illustration. Secure the motor + mounting bracket with bolts (6 bolts).

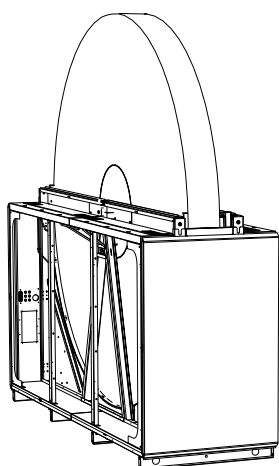

Upper casing section

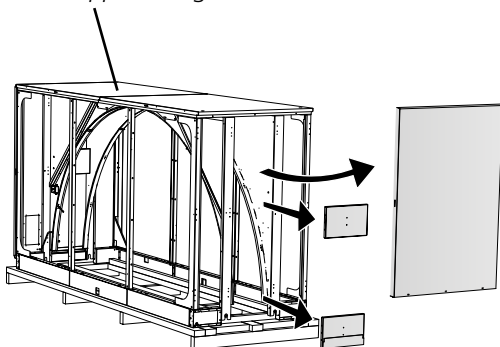

Remove the cover panel on the rear side. Remove the sealing plates (2 pcs.).

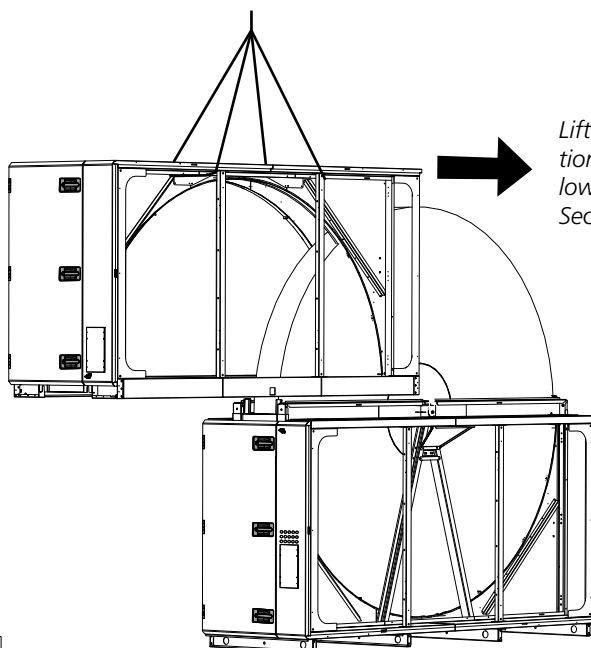

Lift the upper casing section from the side onto the lower casing section (see Section 1.6).

Mount the cover panel and the sealing plates (2 pcs.).

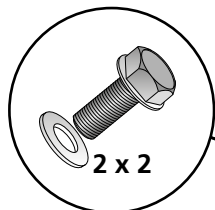
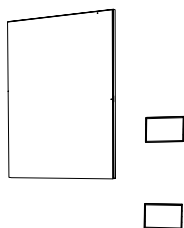

2 x 2

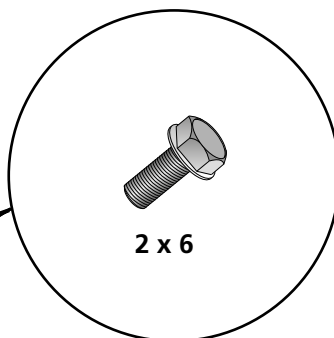
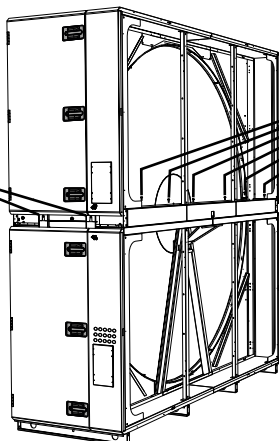

2 x 6

Fix the upper casing section to the lower casing section with the bolts supplied, screwing them into the pre-fitted rivet nuts (a total of 16 pcs.).

See also Section 1.7.3 Common for Alternatives 1 and 2

1.7.3 Common for Alternatives 1 and 2

1.7.3.1 To adjust the rotor's inclination

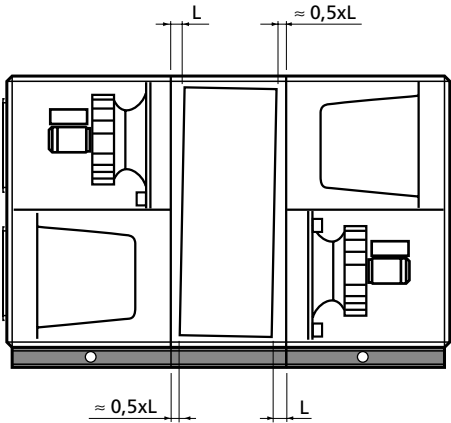

The illustration shows a suitable rotor inclination setting for Fan Arrangement 1. The inclination must always be towards the filter, which means that the inclination for Fan Arrangement 2 is in the other direction.

The rotor's inclination may need to be greater in applications that involve high airflows with associated high pressure.

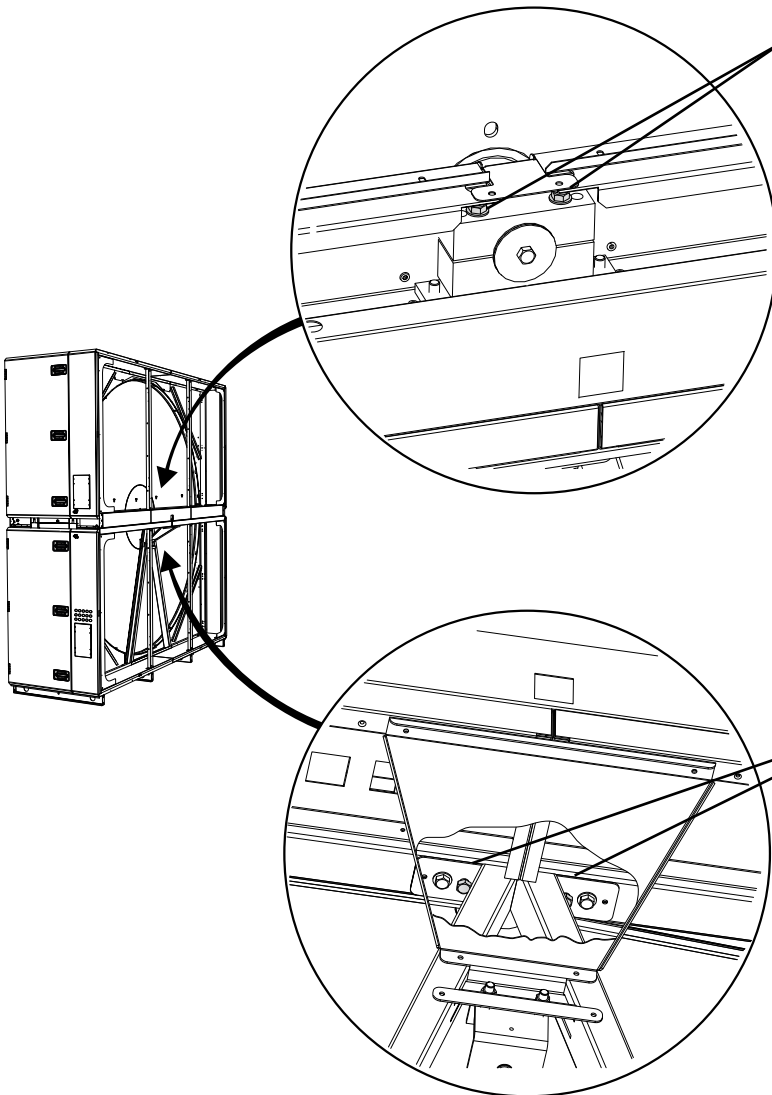

Slightly back off the locking bolts. Do not dismantle the shaft bracket.

Adjust the inclination of the rotor by means of the adjusting bolts. Tighten the adjusting bolts equally.

When you have adjusted the inclination, tighten the locking bolts.

1.7.3.2 Sealing plates/purging sector

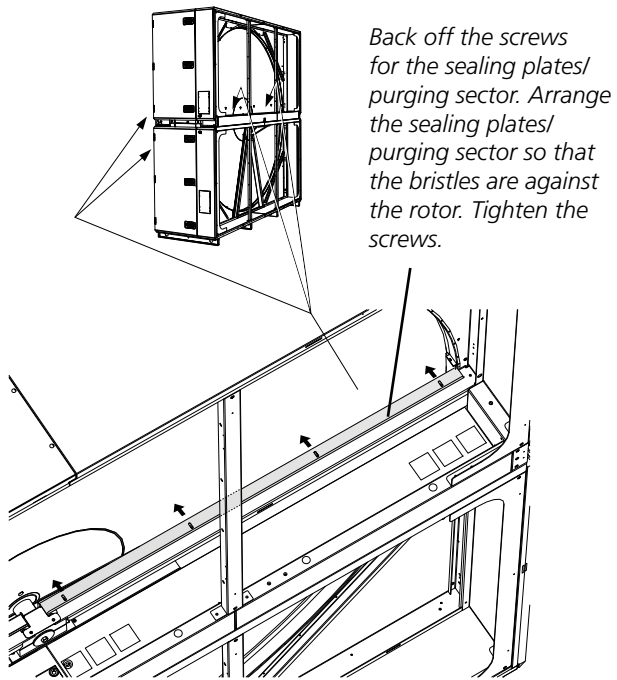

1.7.3.4 Vinyl-coated fabric seal

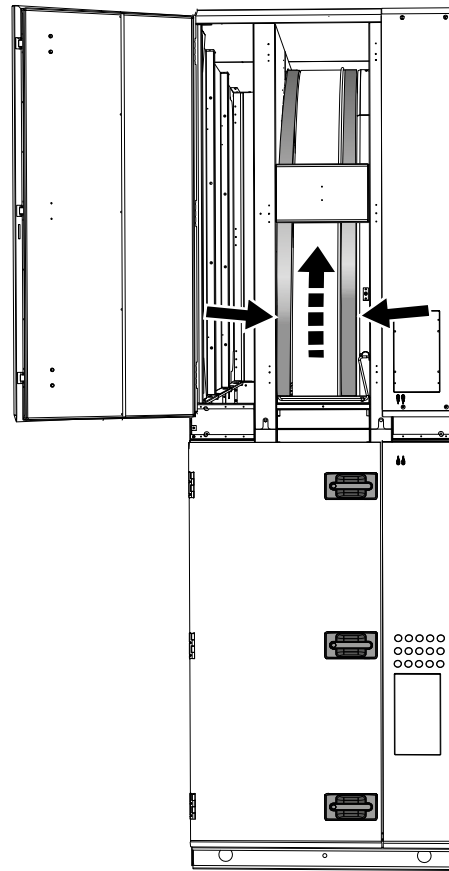

Slip the vinyl-coated fabric seal of the rotor (blue) over the rim all the way around on both sides of the rotor.

1.7.3.3 Pressing roller

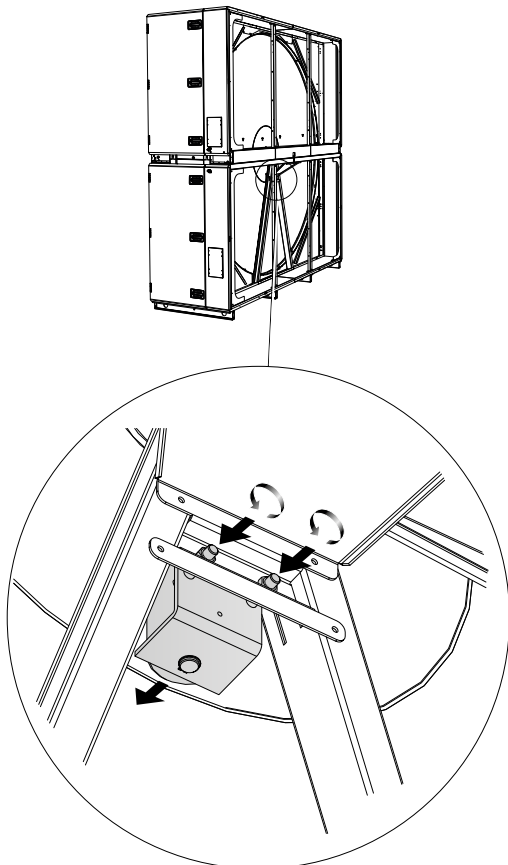

Tension the pressing roller against the rotor hub until you no longer can roll the pressing roller with your hand.

1.7.3.5 Sealing

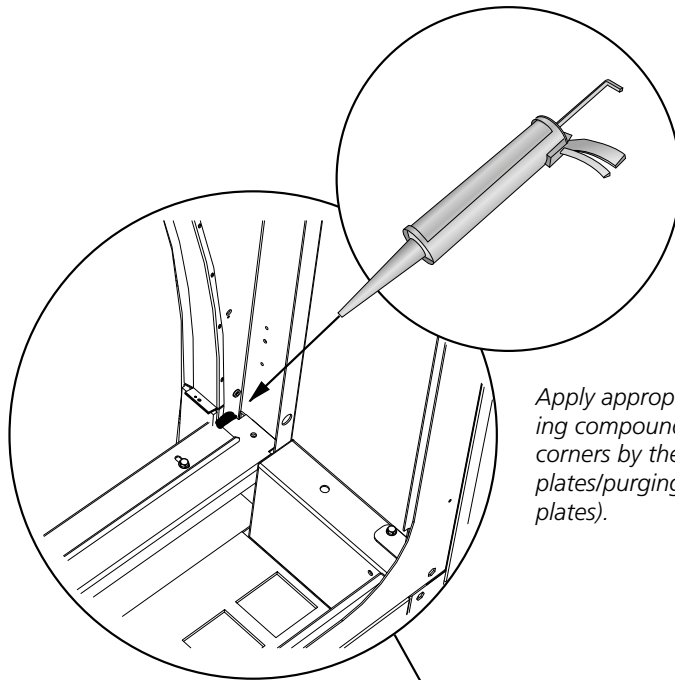

Apply appropriate sealing compound/putty to corners by the sealing plates/purging sector (4 plates).

Apply appropriate sealing compound/putty to the joints between the upper casing section and the lower casing section (front and rear).

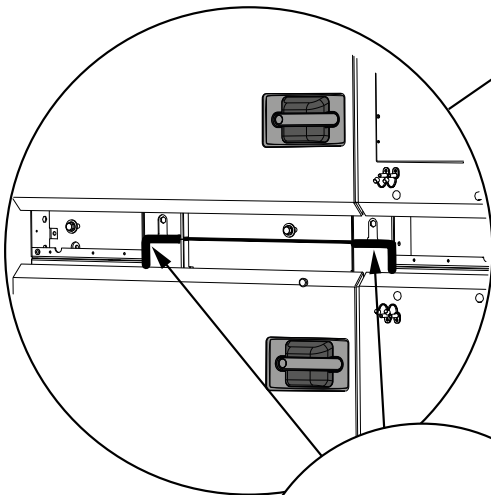
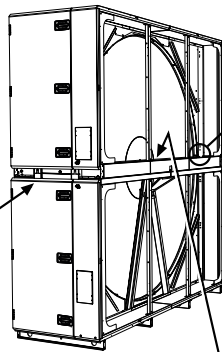

Apply appropriate sealing compound/putty around the sealing plate of the rotor shaft (2 plates).

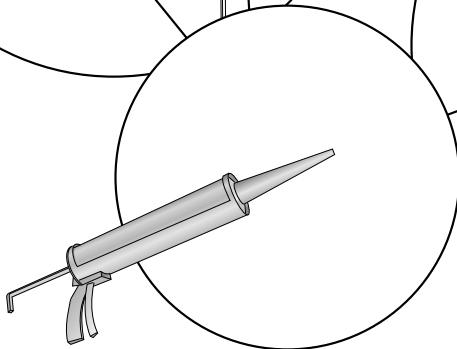
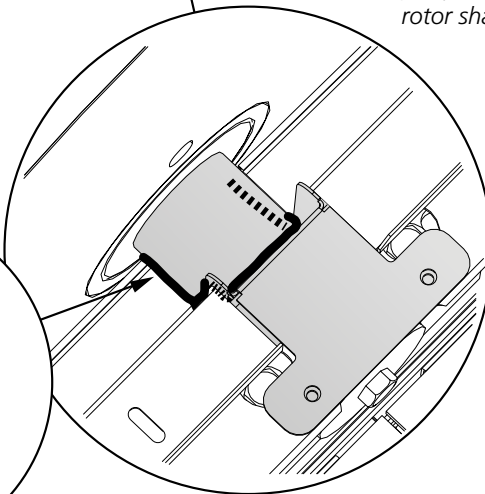

1.8 Version and fan arrangement

1.8.1 SILVER RX

The SILVER RX 120 is delivered in a right-hand or a left-hand version. The arrangement of the functional sections can be vertically reversed (specify when ordering), see the illustration below.

For particulars of the delivery configuration and installation of the relevant air handling unit, see the decal on the lower section of the heat exchanger.

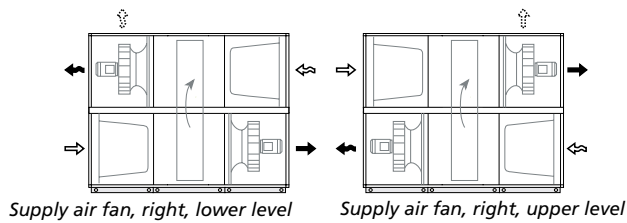

Right-hand version

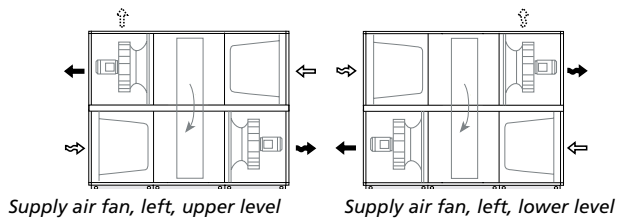

Left-hand version

1.8.2 SILVERX

The SILVERX 120 is supplied in the right-hand or a left-hand version and with Fan Arrangement 1, 2, 4 or 5, see the illustrations below.

For particulars of the delivery configuration and installation of the relevant air handling unit, see the decal on the lower section of the heat exchanger.

NOTE! The supply air fan is marked 1; the extract air fan is marked 2. These identifying decals are affixed to the inner wall of the fan sections.

NOTE! If extract air flows through the lower level: The air handling unit must be raised at least 50 mm (Higher than the upper edge of the base beams) to provide space for the water trap.

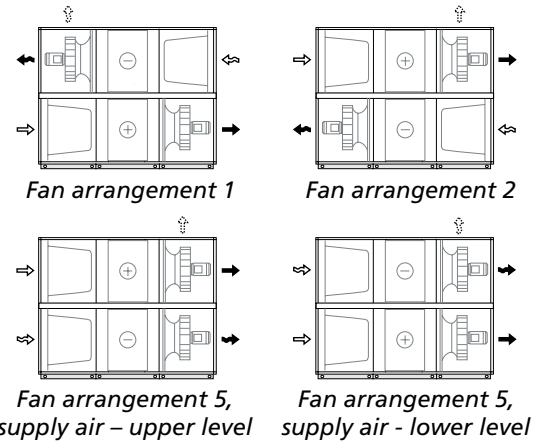

Right-hand version

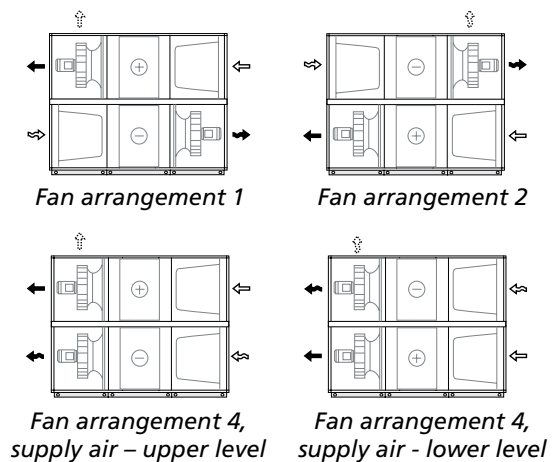

Left-hand version



1.9 The docking of unit sections

The illustrations in Section 1.10 show a SILVER RX unit with Fan Arrangement 2. The principle is however the same for the other units.

1.9.1 Fan/filter/coil heat exchanger sections (Coil heat exchanger sections SILVERX only)

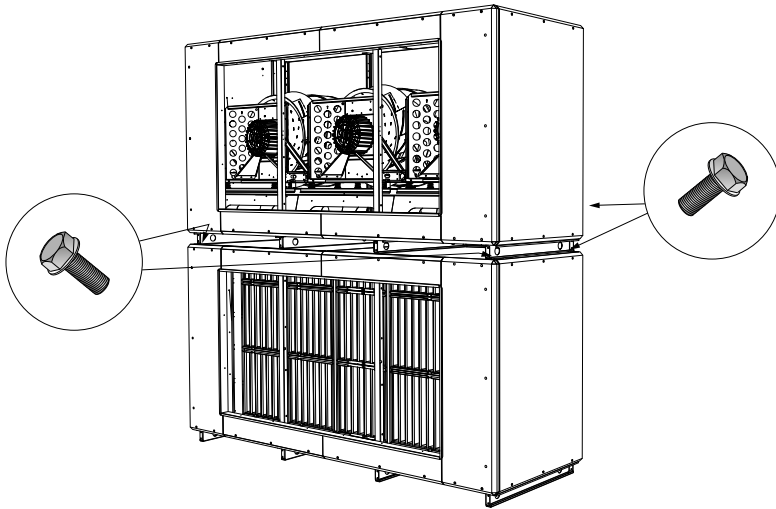

Place the fan, filter and possible coil heat exchanger sections on top of one another, according to the delivery configuration (see Section 1.8). Secure the upper section to the lower section with the bolts supplied, screwing them into the pre-fitted rivet nuts (a total of 4 pcs.).

1.9.2 Fastening, front/middle section

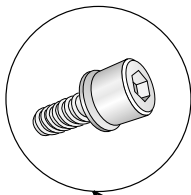

Locate the fan/filter sections by the heat exchanger section according to the delivery configuration (see Section 1.8). Fix the fan/filter sections at the front side of the air handling unit to the heat exchanger section with the bolts supplied, screwing them into the prefitted rivet nuts (a total of 2x4 pcs.).

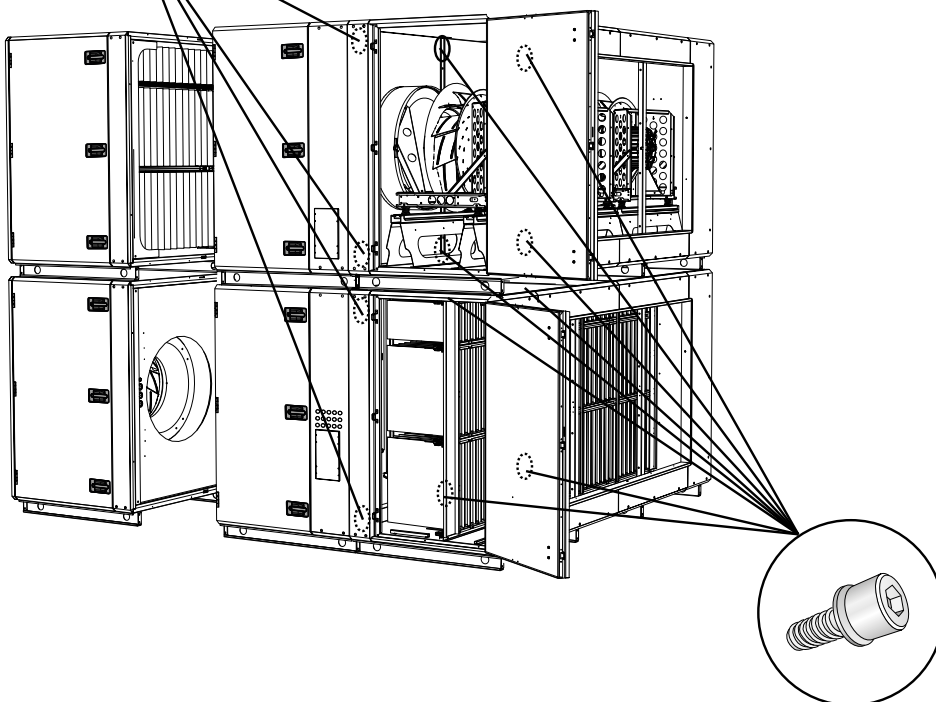

Secure the fan/filter sections to the heat exchanger section inside the air handling unit's middle section using the supplied screws in the pre-fitted rivet nuts (total 2x8 pcs.). The anchoring points inside the unit are shown in the illustration.

In order to access the anchor points in the fan section, you must unfasten the flexible connections and the fan assemblies and move them outward toward the inspection door. You can then tighten the screws from the opening of the duct connection.
NOTE! You do not need to remove the fan assemblies completely!

1.9.3 Fixation, rear of the unit

Securing with screws at the rear of the air handling unit can be done in two ways, internally or externally. External fixing (Alt. 1) is appropriate for use if there is sufficient free space behind the air handling unit, since this alternative is simpler. If sufficient space is not available, Alt. 2) can be used.

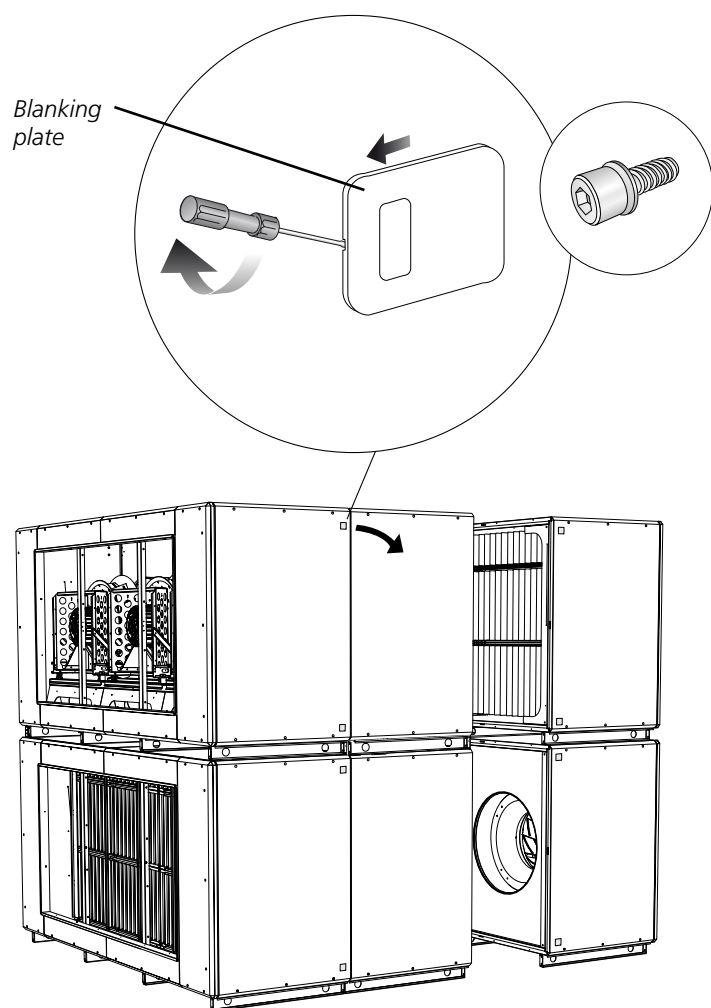

Alt. 1

External fixing.

Dismantle the blanking plate and insulation inside the cover on the rear side of the air handling unit. Secure the fan/filter sections to the heat exchanger section with the bolts supplied, screwing them into the pre-fitted rivet nuts (a total of 2x4 pcs.). Refit the blanking plate and the insulation.

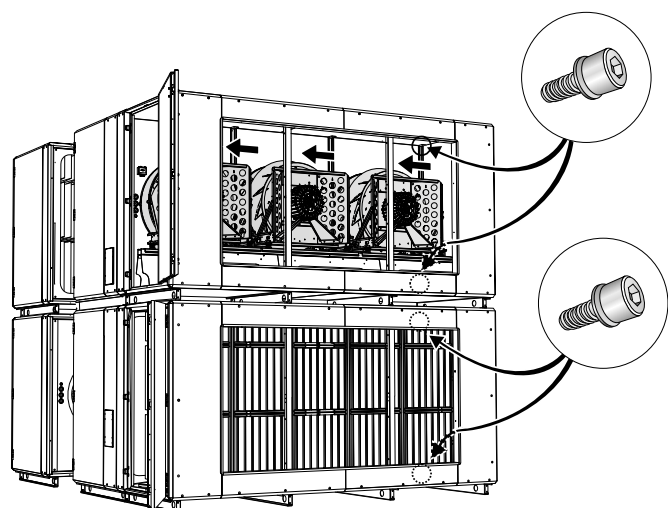

Alt. 2

Internal installation.

Secure the fan/filter sections to the heat exchanger section with the bolts supplied, screwing them into the pre-fitted rivet nuts (a total of 2x4 pcs.). The anchoring points inside the unit are shown in the illustration.

In order to access the anchor points in the fan section, you must unfasten the flexible connections and the fan assemblies and move them outward toward the inspection door. You can then tighten the screws from the opening of the duct connection.

N.B.! *You do not need to remove the fan assemblies completely!*

1.10 Duct connection

The air handling unit's connection frames are rectangular and can be jointed to ducts by means of slip-clamps.

The ducts should be insulated according to local regulations and customary trade standards.

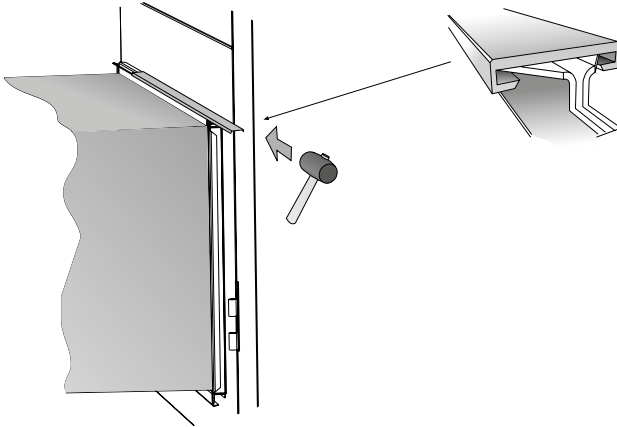
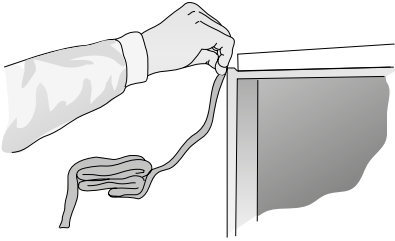

1.11 Electrical Connections.

The electrical connections should be wired by a qualified electrician in accordance with local electrical safety regulations.

See the separate instructions for electrical connections of the fan motors, heat exchanger control system, actuators, etc.

1.12 Installation of pipework package (SIL-VERX only)

For details on how to install the pipework package, see separate instructions for the TBXZ-42 pipework package.

2. Dimensions

2.1 SILVER RX 100/120

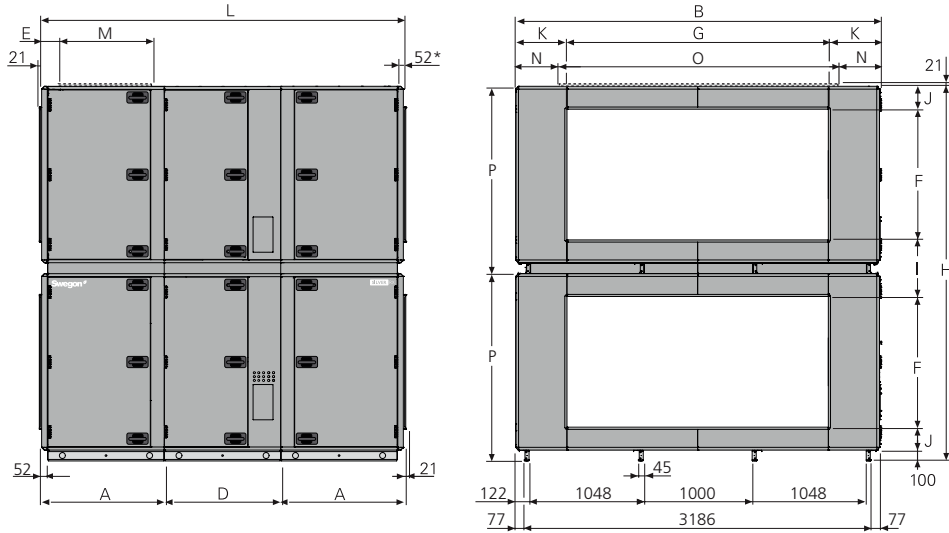

* The air handling unit is supplied without end connection panel if a duct accessory housed in an insulated casing will be connected. The AHU can also be supplied with full face end connection panel (accessory).

Size	A	B	D	E	F	G	H	I	J	K	L	M	N	O	P	Weight, kg
100	1122	3340	1070	187	1200	2400	3440	520	210	470	3314	800	420	2500	1720	3333-3761
120	1122	3340	1070	187	1200	2400	3440	520	210	470	3314	800	420	2500	1720	3533-3979

Individual weights

Filter section

SILVER 100/120: 402-540 kg/section.

Fan section

SILVER 100: 644-720 kg/section.

SILVER 120: 744-829kg/section.

Heat exchanger section, mounted

SILVER 100/120: 1241 kg.

Heat exchanger section, supplied in two casing sections + rotor

Lower casing section = 513 kg

Upper casing section = 300 kg

Rotor = 428 kg

Transport cradle = 190 kg

2.2 SILVERX 100/120

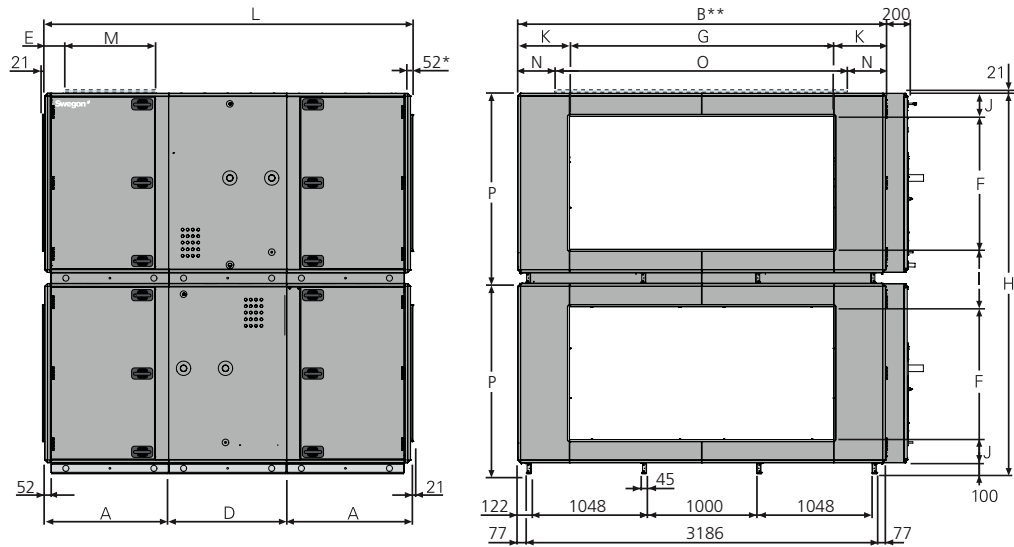

* If the duct accessory is housed in an insulated casing, the AHU is supplied without the end connection panel. The AHU can also be supplied with full face end connection panel (accessory).

** Width of centre section's casing = $B + 200$ mm.

Size	A	B	D	E	F	G	H	I	J	K	L	M	N	O	P	Weight, kg
100	1122	3340	1070	187	1200	2400	3440	520	210	470	3314	800	420	2500	1720	4294-4772
120	1122	3340	1070	187	1200	2400	3440	520	210	470	3314	800	420	2500	1720	4494-4990

Individual weights

Filter section

SILVER 100/120: 402-540 kg/section.

Fan section

SILVER 100: 644-720 kg/section.

SILVER 120: 744-829 kg/section.

Heat exchanger section

SILVER 100/120: 1101-1126 kg/section.