

SILVER RX/PX/CX

Air Handling Unit

INSTALLATION INSTRUCTIONS



EN - Installation instructions
SE - Installationsanvisning
DE - Installationsanleitung
FR - Instructions d'installation
NO - Installasjonsanvisning
DK - Installationsanvisning
FI - Asennusohje
PL - Instrukcja instalacji
RU - Инструкция по монтажу
ES - Instrucciones de instalación
IT - Istruzioni per l'installazione
PT - Instruções de instalação
NL - Installatie instructies

CONTENTS

The document was originally written in Swedish.

EN - CONTENTS

1. Key to symbols	4
2. Lifting	5-6
3. Unpacking	7
4. Serial number	7
5. Splitting/Installation of air handling unit sections	8-9
6. Placement	10-11
7. Water trap	12
8. Connection to the Ducting	13-14
9. Electrical Connections	15
10. Airflow direction	15

NO - INNHOLDSFORTEGNELSE

1. Tegnforklaring	4
2. Løfte	5-6
3. Oppakning	7
4. Serienummer	7
5. Deling/montering av aggregatseksjoner	8-9
6. Plassering	10-11
7. Vannlås	12
8. Tilkobling kanaler	13-14
9. El-tilkobling	15
10. Luftretning	16

SE - INNEHÅLLSFÖRTECKNING

1. Teckenförklaring	4
2. Lyft	5-6
3. Uppackning	7
4. Serienummer	7
5. Delning/Montage av aggregatsektioner	8-9
6. Placering	10-11
7. Vattenlås	12
8. Anslutning kanaler	13-14
9. Elanslutning	15
10. Luftriktning	15

DK - INHOLDSFORTEGNELSE

1. Tegnforklaring	4
2. Løfte	5-6
3. Udpakning	7
4. Serienummer	7
5. Deling/Montering af aggregatsektioner	8-9
6. Placering	10-11
7. Vandlås	12
8. Tilslutning, kanaler	13-14
9. El-tilslutning	15
10. Luftretning	15

DE - INHALTSVERZEICHNIS

1. Zeichenerklärung	4
2. Anheben	5-6
3. Auspacken des Zubehörs	7
4. Seriennummer	7
5. Zerlegung/Montage von Gerätesektionen	8-9
6. Innenaufstellung	10-11
7. Siphon	12
8. Anschluss Kanäle	13-14
9. Elektroanschluss	15
10. Luftrichtung	15

FI - SISÄLLYSLUETTELO

1. Merkkien selitys	4
2. Nostaminen	5-6
3. Pakkauksen purkaminen	7
4. Sarjanumero	7
5. Koneen osien erottaminen/yhdistäminen	8-9
6. Sijoitus	10-11
7. Vesilukko	12
8. Kanavaliitäntä	13-14
9. Tehonsyöttöliitäntä	15
10. Ilmavirran	15

FR - TABLE DE MATIÈRES

1. Explication des symboles	4
2. Levage	5-6
3. Déballage	7
4. Numéro de série	7
5. Désassemblage/Assemblage des sections d'une centrale de traitement d'air	8-9
6. Positionnement	10-11
7. Siphon	12
8. Raccordement canaux	13-14
9. Raccordement électrique	15
10. Sens de circulation de l'air	15

PL - SPIS TREŚCI

1. Oznaczenia symboli	4
2. Transport pionowy	5-6
3. Rozpakowanie-części składowe centrali	7
4. Numery seryjne	7
5. Podział/Montaż sekcji centrali	8-9
6. Posadowienie centrali	10-11
7. Syfon wodny	12
8. Podłączenie przewodów powietrza	13-14
9. Włącznik główny	15
10. Zmiana kierunku przepływu powietrza	15

CONTENTS

RU - Оглавление

1. Обозначения	4
2. Подъем краном	5-6
3. Распаковывание	7
4. Серия-номер	7
5. Разделение/Монтаж секций агрегата	8-9
6. Установка	10-11
7. Водяной затвор	12
8. Присоединение	13-14
9. Подключение питания	15
10. Изменение направления воздуха	15

PT - ÍNDICE

1. Explicação de símbolos	4
2. Levantar	5-6
3. Desembalagem	7
4. Número de série	7
5. Divisão/instalação de secções de unidades	8-9
6. Colocação	10-11
7. Sifão	12
8. Ligação canais	13-14
9. Ligação eléctrica	15
10. Direcção do ar	15

ES - ÍNDICE

1. Explicación de los símbolos	4
2. Elevación	5-6
3. Desembalaje	7
4. Número de serie	7
5. División/instalación de secciones de la unidad de tratamiento de aire	8-9
6. Ubicación	10-11
7. Colector de agua	12
8. Conductos de conexión	13-14
9. Conexión eléctrica	15
10. Dirección del aire	15







NL - INHOUDSOPGAVE

1. Legenda	4
2. Het opheffen	5-6
3. Uitpakken	7
4. Serienummer	7
5. Verdeling/installatie van secties van de luchtbehandelingsunit	8-9
6. Plaatsing	10-11
7. Sifon	12
8. Aansluiten kanalen	13-14
9. Aansluiten	15
10. Luchtrichting	15

IT - INDICE

1. Legenda	4
2. Sollevamento	5-6
3. Disimballaggio	7
4. Numero di serie	7
5. Suddivisione/installazione sezioni delle unità di trattamento dell'aria	8-9
6. Posizionamento	10-11
7. Sifone	12
8. Collegamento dei canali	13-14
9. Collegamenti elettrici	15
10. Direzione dell'ariai	15

1.

					
EN Warning	Protect from moisture	Outdoor air	Supply air	Extract air	Exhaust air
SE Varning	Skyddas från väta	Uteluft	Tilluft	Frånluft	Avluft
DE Warnung	Vor Nässe schützen	Außenluft	Zuluft	Abluft	Fortluft
FR Avertissement	Protéger contre l'humidité	Air extérieur	Air de pulsion	Air extrait	Air rejeté
NO Advarsel	Beskyttes fra væte	Uteluft	Tilluft	Avtrekksluft	Avkast
DK Advarsel	Beskyttes mod væde	Friskluft	Indblæsningsluft	Udsugningsluft	Afgangsluft
FI Varoitus	Suojattava kastumiselta	Ulkoilma	Tuloilma	Poistoilma	Jäteilma
PL Uwaga!	Chronić przed wilgocią	Powietrze zewnętrzne	Powietrze nawiewane	Powietrze wywiewane	Powietrze wyrzucane
RU Внимание	Защитить от влаги	Наружный воздух	Приточный воздух	Отработанный воздух	Вытяжной воздух
ES Advertencia	Proteger contra la humedad	Aire exterior	Aire de impulsión	Aire de retorno	Aire de extracción
IT Avvertenza	Teme l'umidità	Aria esterna	Aria in entrata	Aria in uscita	Sfiato
PT Aviso	Proteger contra a humidade	Ar exterior	Ar de entrada	Ar de saída	Ar de extracção
NL Waarschuwing	Tegen vocht beschermen	Buitenlucht	Inlaatlucht	Uitlaatlucht	Afvoerlucht



SILVER 004/005, 007/008, 011/012, 014/020, 014+/020+, 025/030, 025+/030+,
035/040, 040+, 050/060, 050+/060+, 070/080

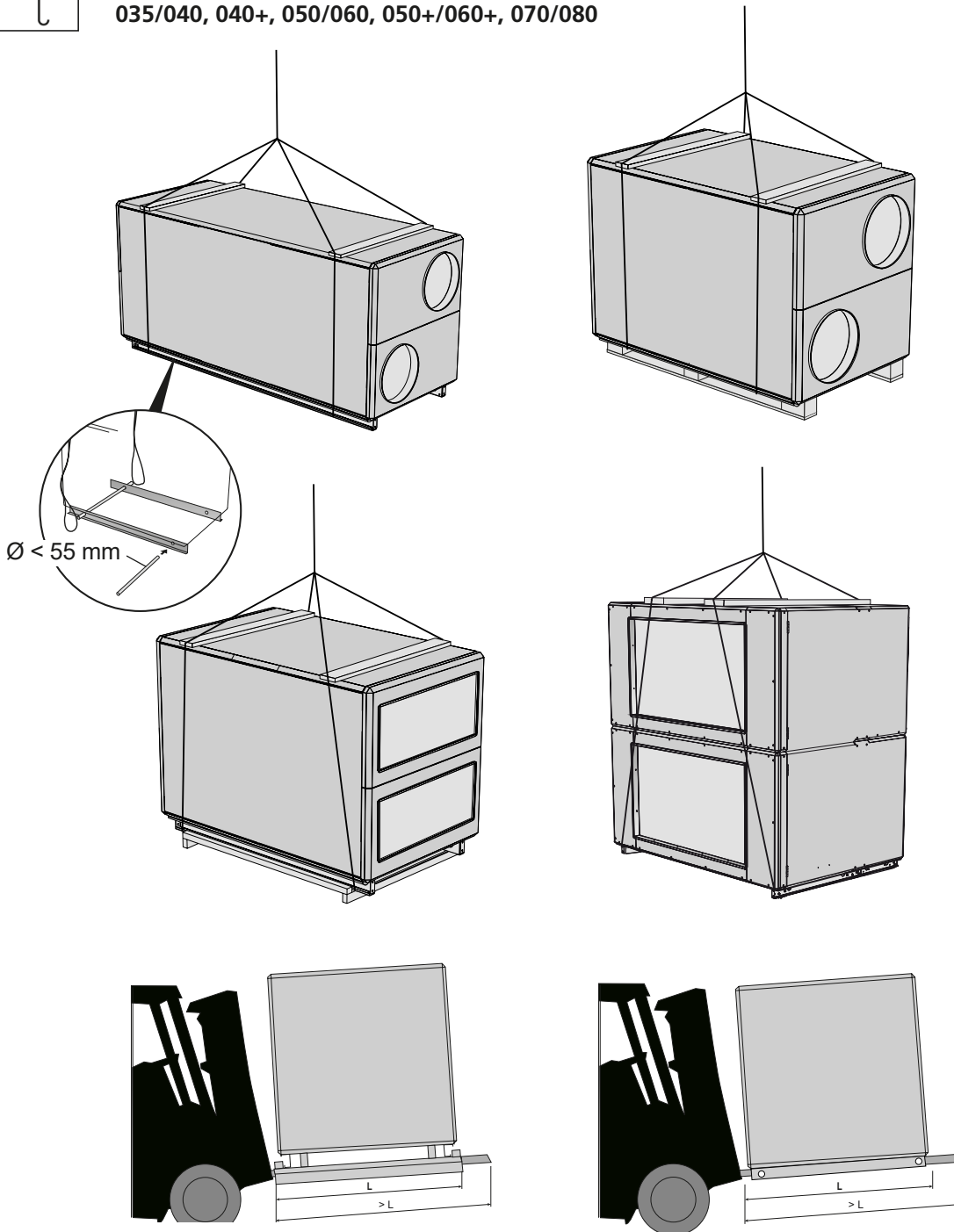

- EN - For weights, see the relevant package
- SE - För vikter, se respektive kolli
- DE - Für Gewichte siehe jeweilige Verpackung
- FR - Les poids figurent sur les emballages correspondants.
- NO - For vekt se respektive kolli
- DK - Se det pågældende kolli for vægtoplysninger
- FI - Katso painot vastaavista kolleista
- PL - Waga, patrz odpowiednie sekcje.
- RU - Вес, см. на упаковке
- ES - Consulte los pesos en el paquete correspondiente
- IT - Per i pesi, vedere il relativo pacchetto
- PT - Para os pesos, ver o equipamento relevante
- NL - Voor gewichten, zie het relevante pakket

SILVER 004/005, 007/008 split version
SILVER 011/012, 014/020, 025/030, 035/040, 050/060

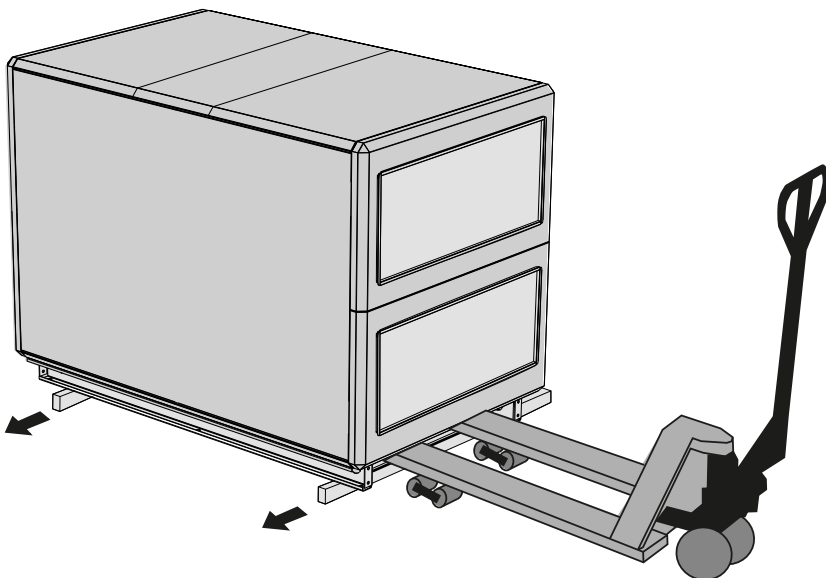
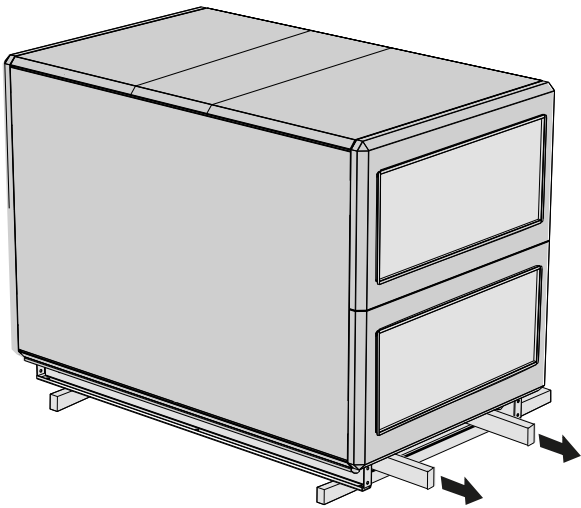
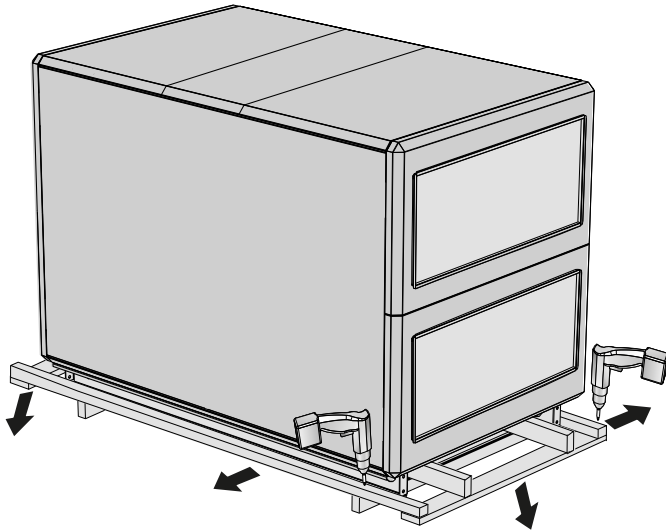

3.

SILVER 004/005, 007/008, 011/012, 014/020, 014+/020+,
025+/030+, 035/040, 040+, 050/060, 050+/060+, 070/080

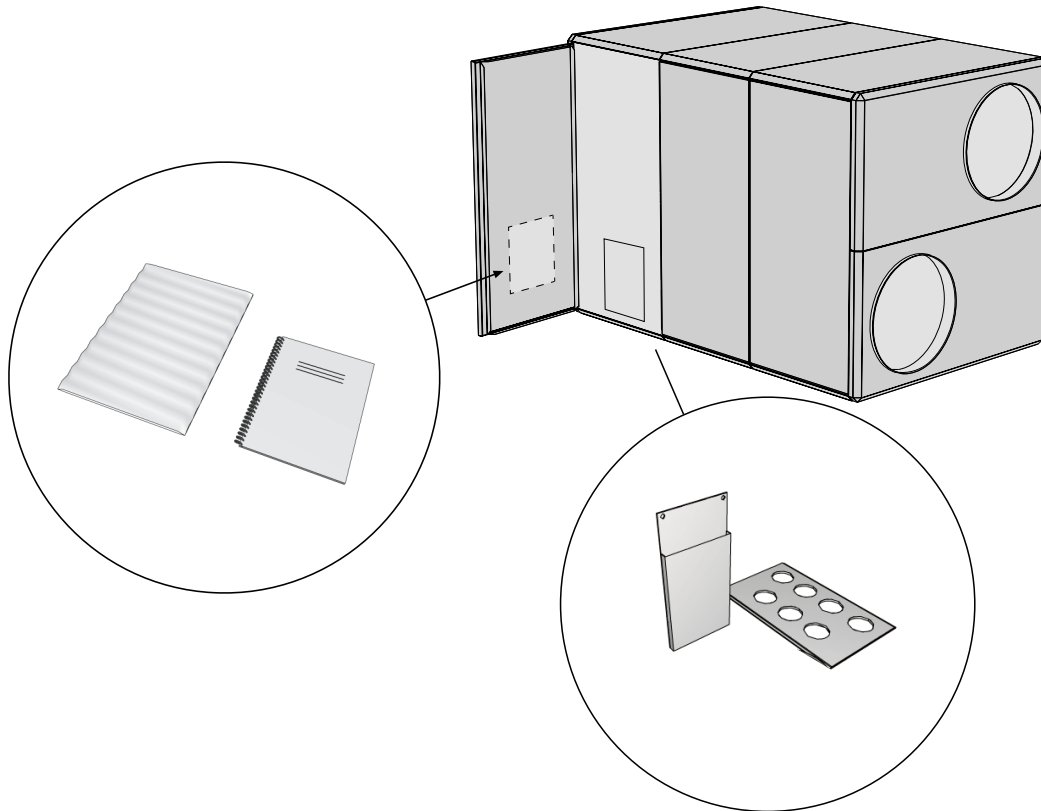

4.

SILVER 004/005, 007/008, 011/012, 014/020, 014+/020+,
025+/030+, 035/040, 040+, 050/060, 050+/060+, 070/080

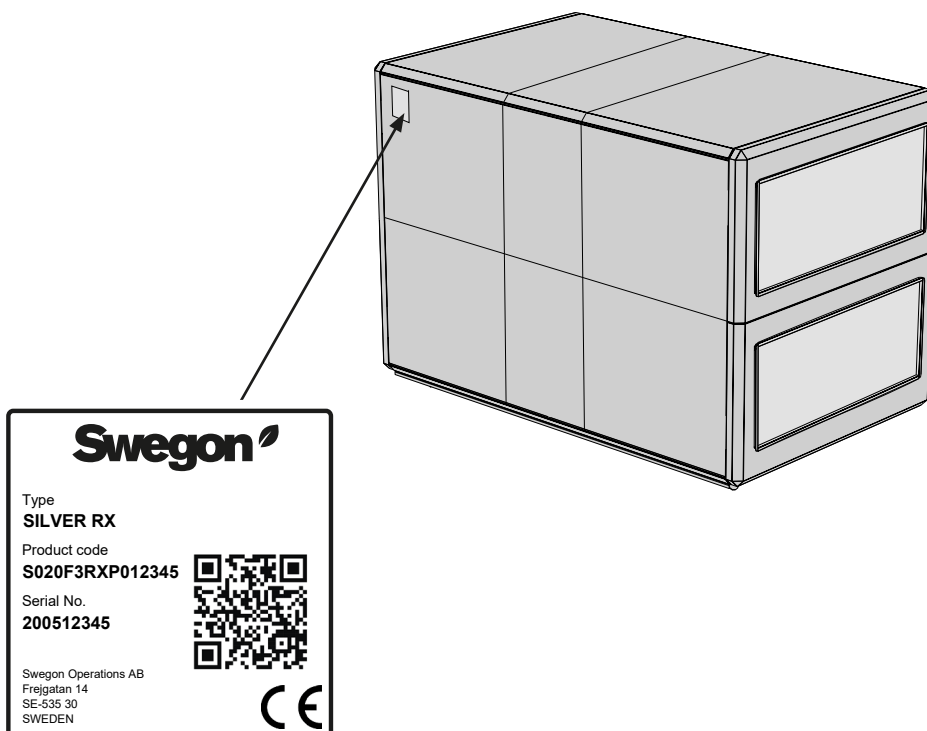

SILVER 004/005, 007/008, 011/012, 014/020, 014+/020+, 025/030, 025+/030+●
 SILVER 035/040, 040+, 050/060, 050+/060+●♻️
 SILVER 070/080●♻️

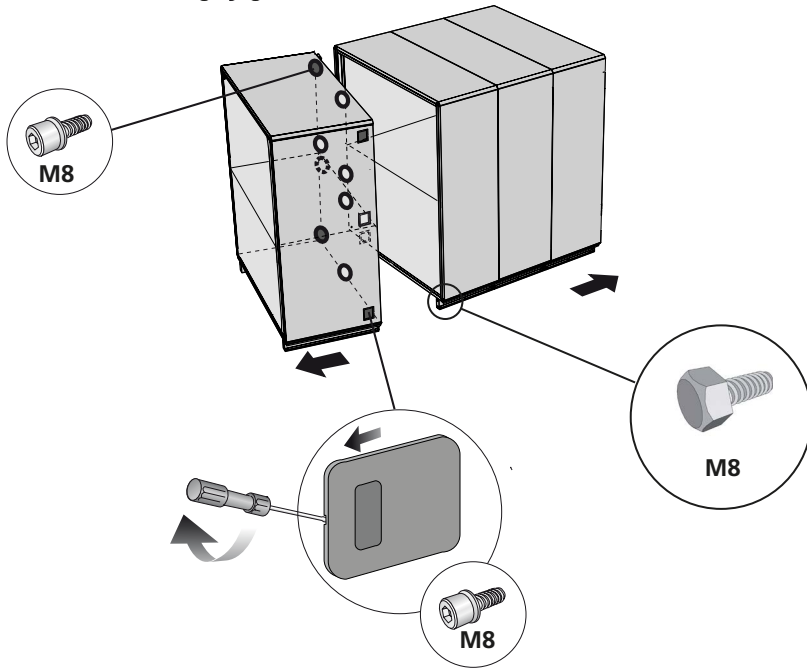

Alt. 1

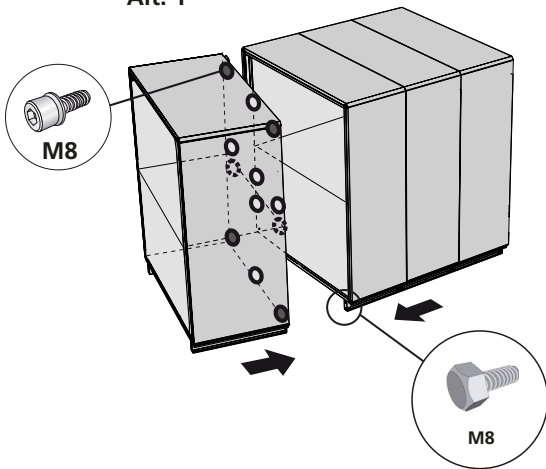

Alt. 2

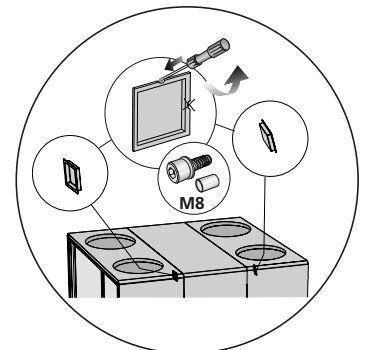
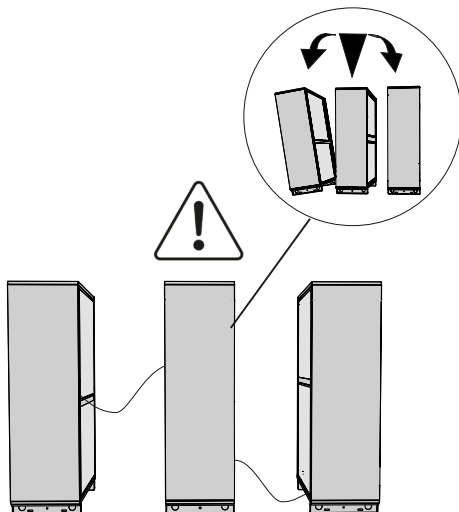
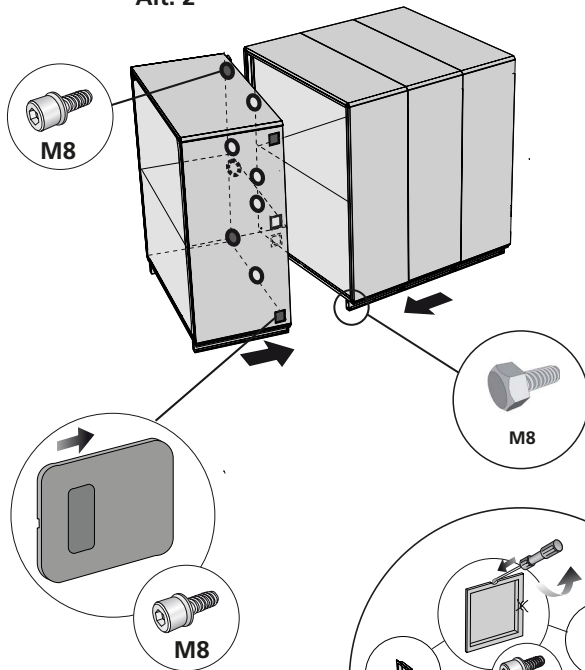

SILVER RX Top 012

5.

SILVER PX 035/040, 040+, 050+/060+, 070/080

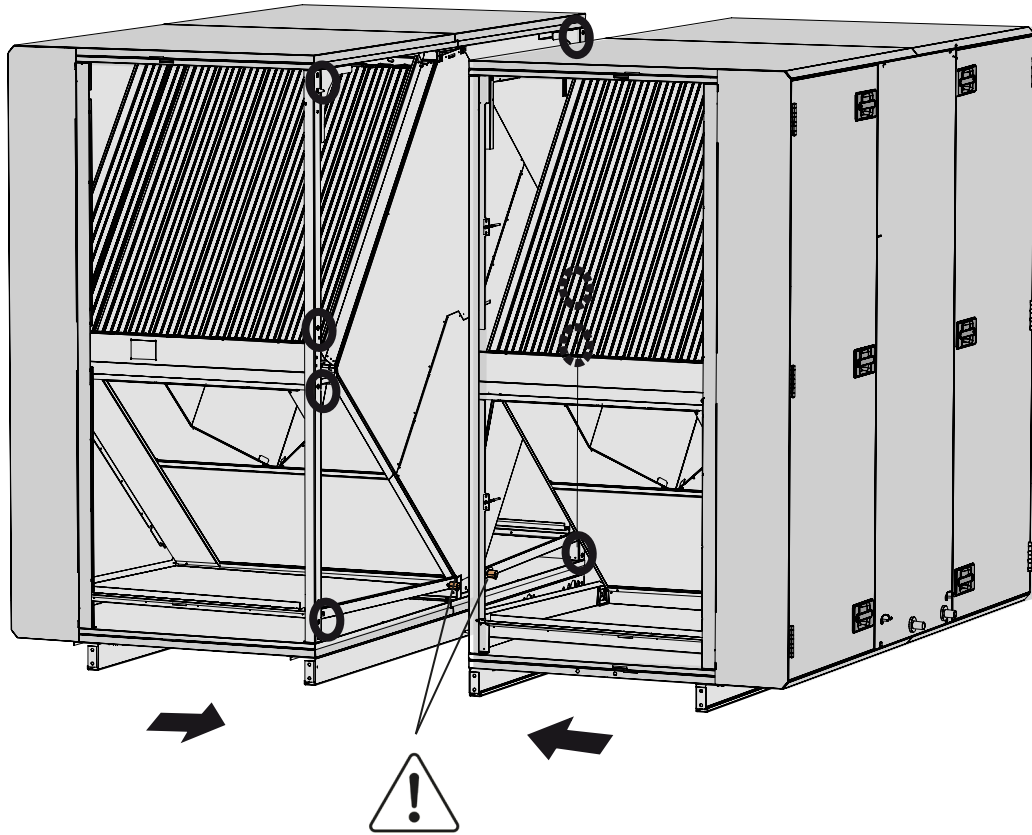

D list 10 x 12
(x 2)

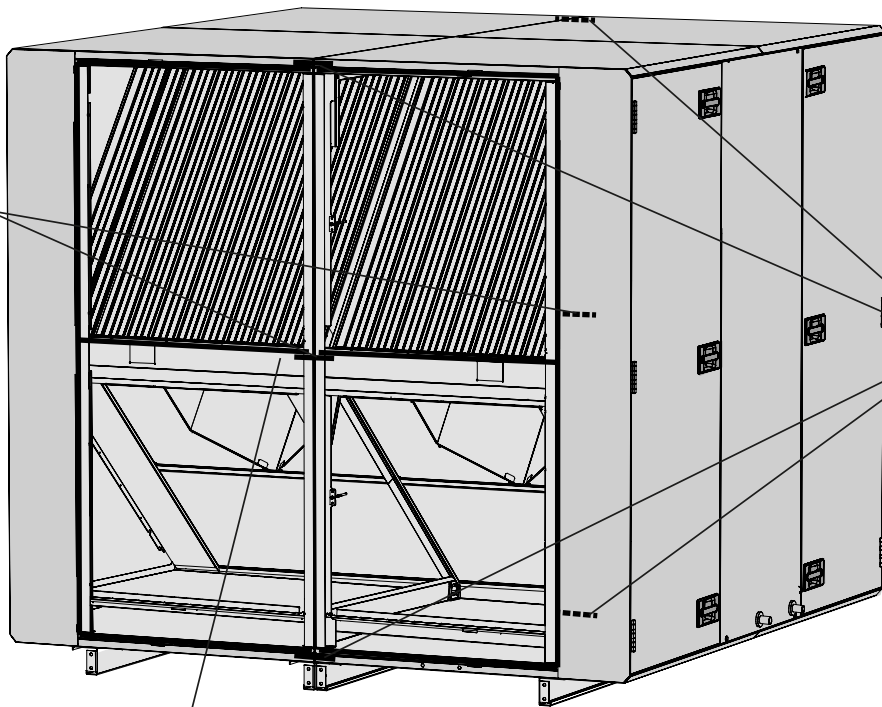

D list 6 x 8
(x 4)

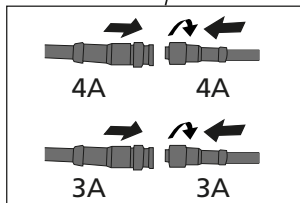

SILVER RX 004/005, 007/008

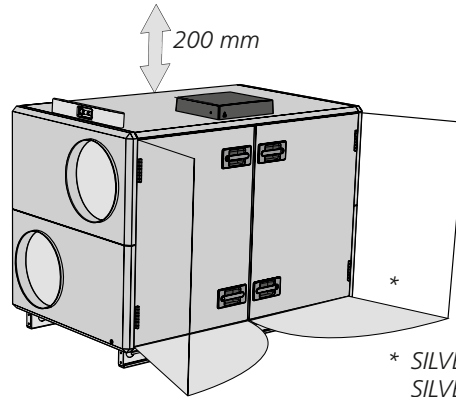
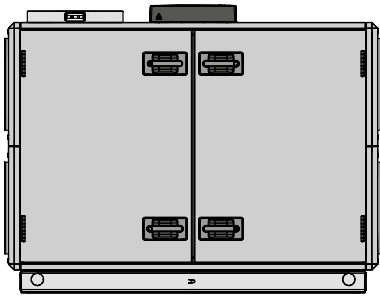

* SILVER RX 004/005 = 800 mm
SILVER RX 007/008 = 900 mm

SILVER RX 004/005, 007/008

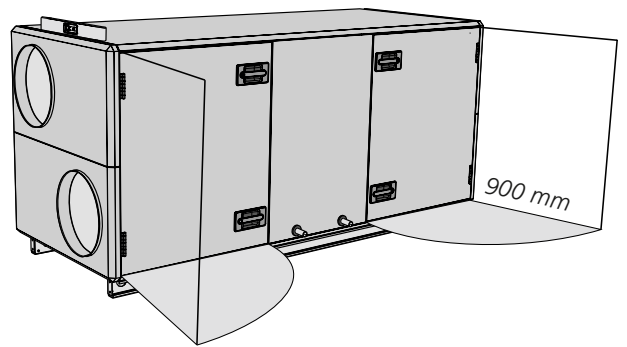
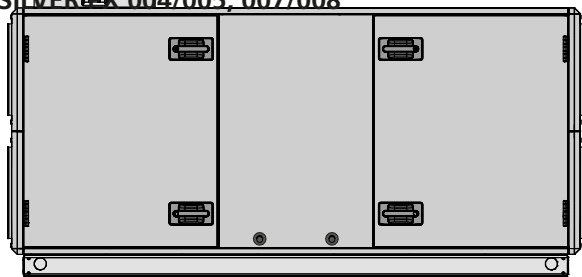

SILVER 011/012, 014/020, 014+/020+

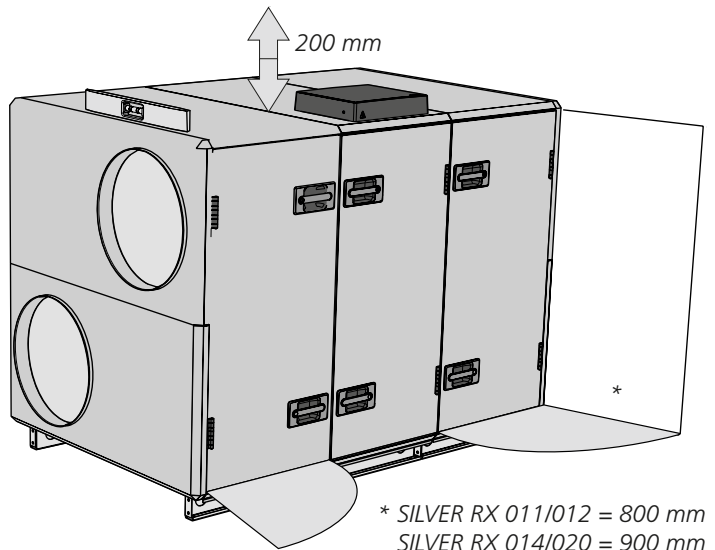
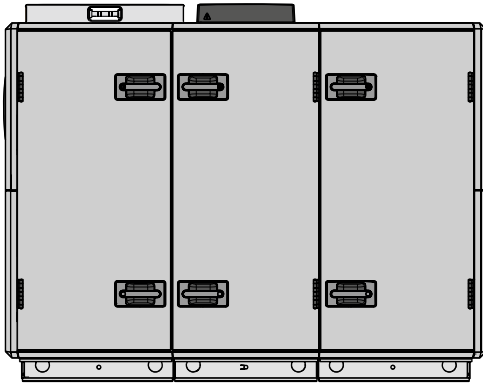

* SILVER RX 011/012 = 800 mm
SILVER RX 014/020 = 900 mm
SILVER PX 011/012, 014/020 = 900 mm
SILVER RX/PX Top 014/020 = 1000 mm

SILVER 025/030, 025+/030+

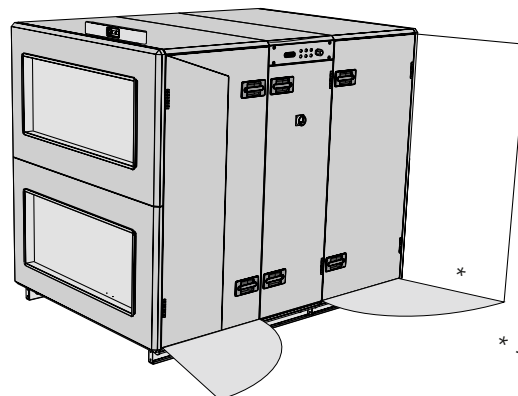
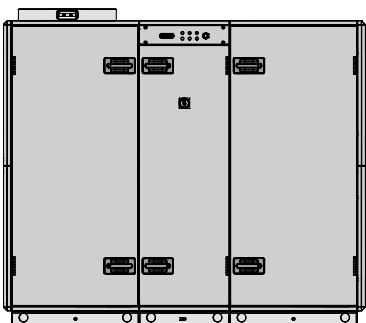

* SILVER RX/PX 025/030 = 900 mm
SILVER RX 014/020 = 900 mm

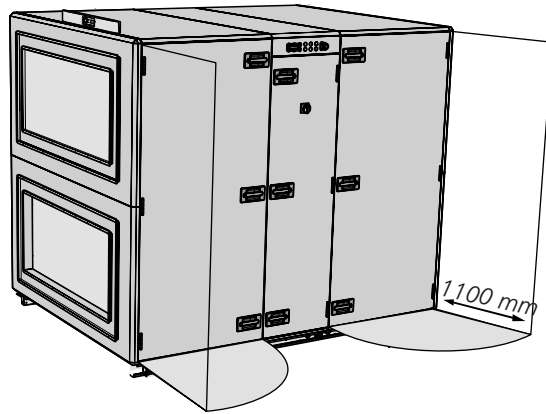
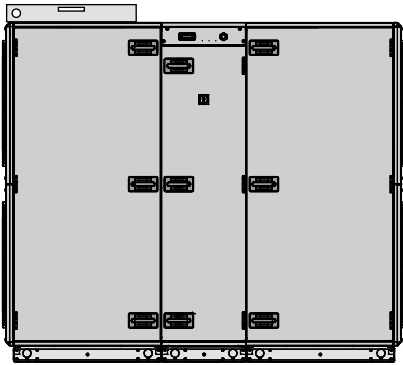
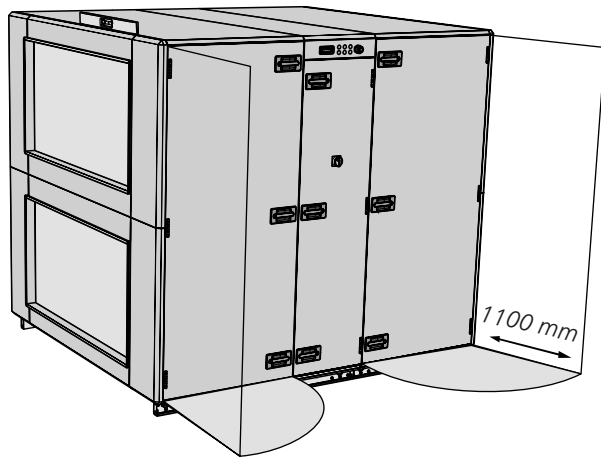
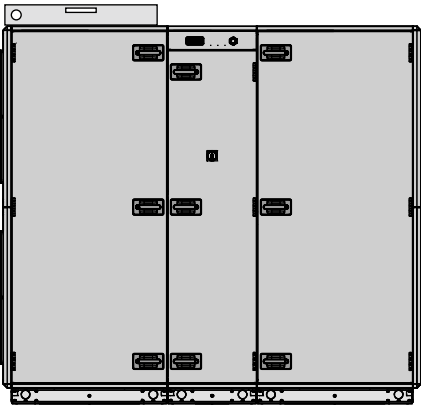
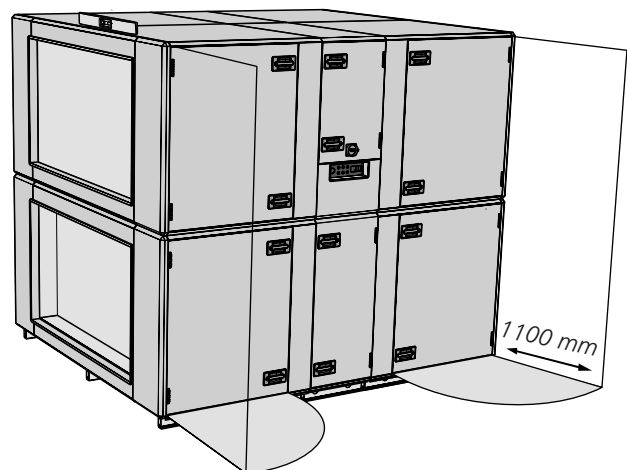
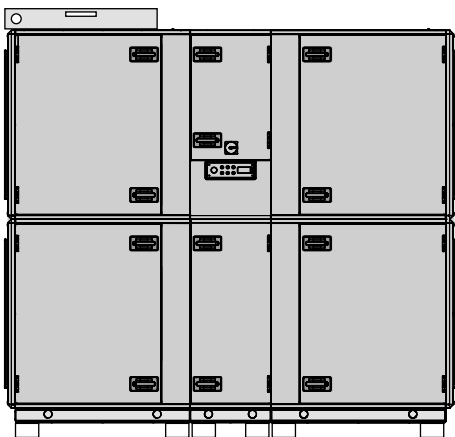
SILVER 035/040, 040+**SILVER 050/060, 050+/060+****SILVER 070/080**

SILVER PX/CX

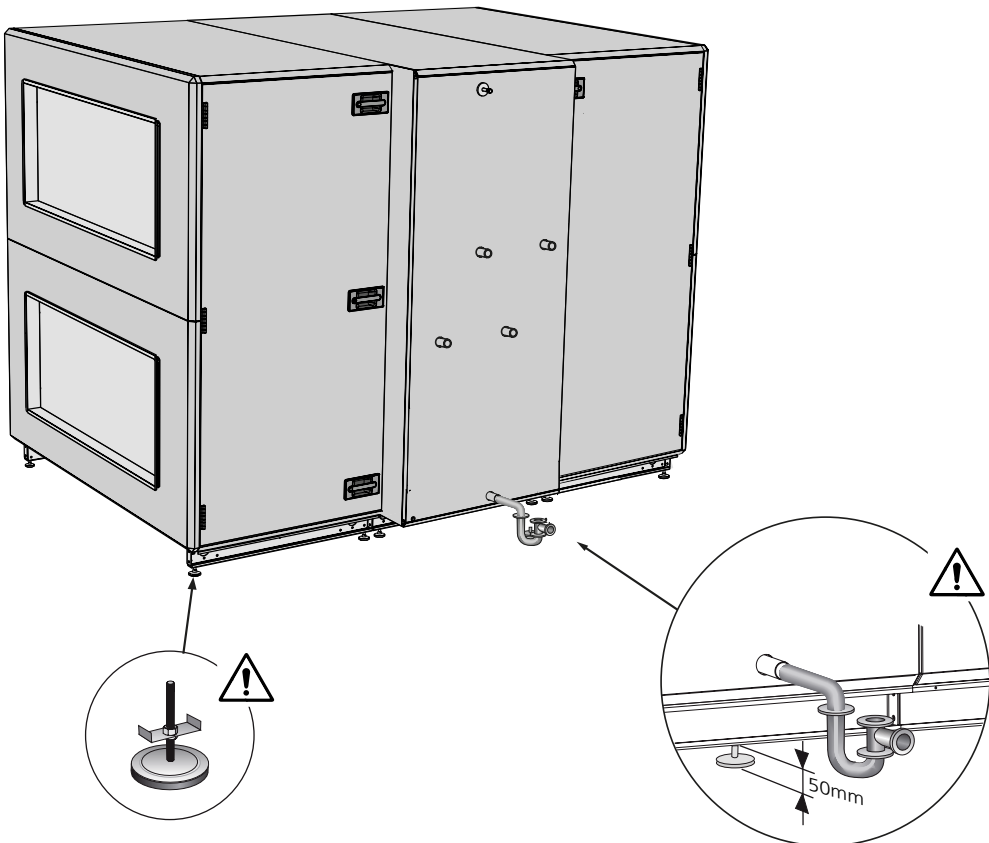
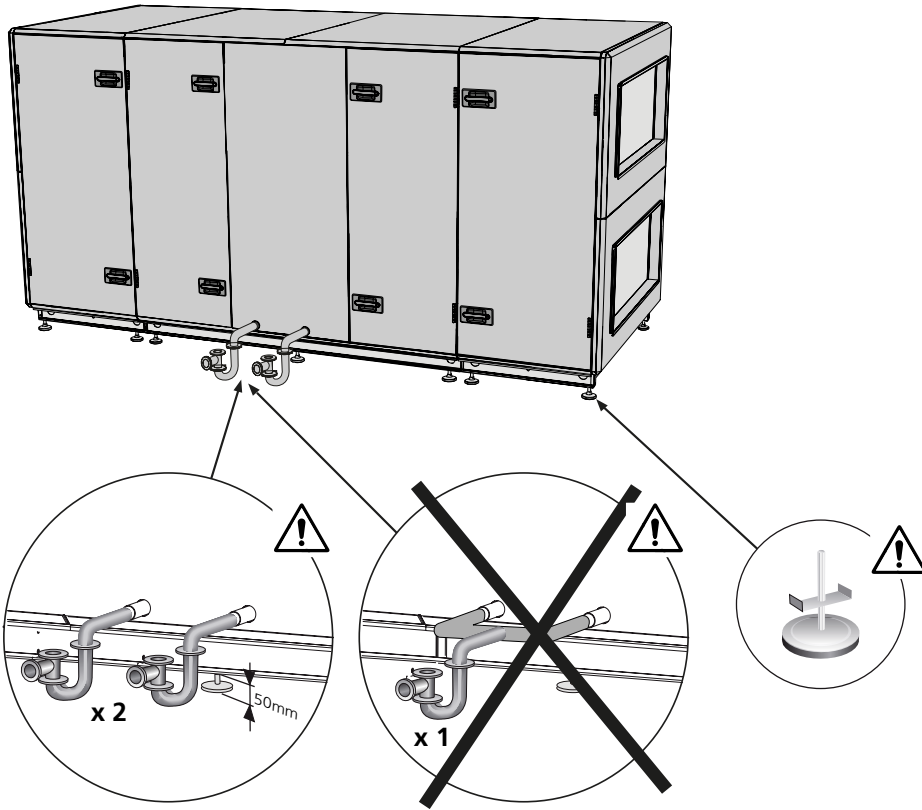

SILVER 004/005, 007/008, 011/012

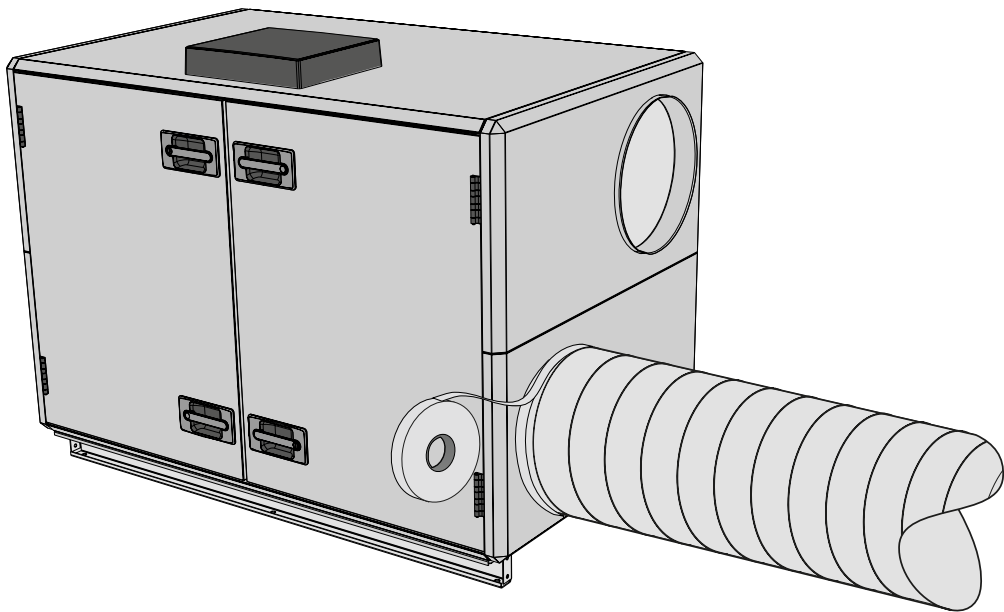
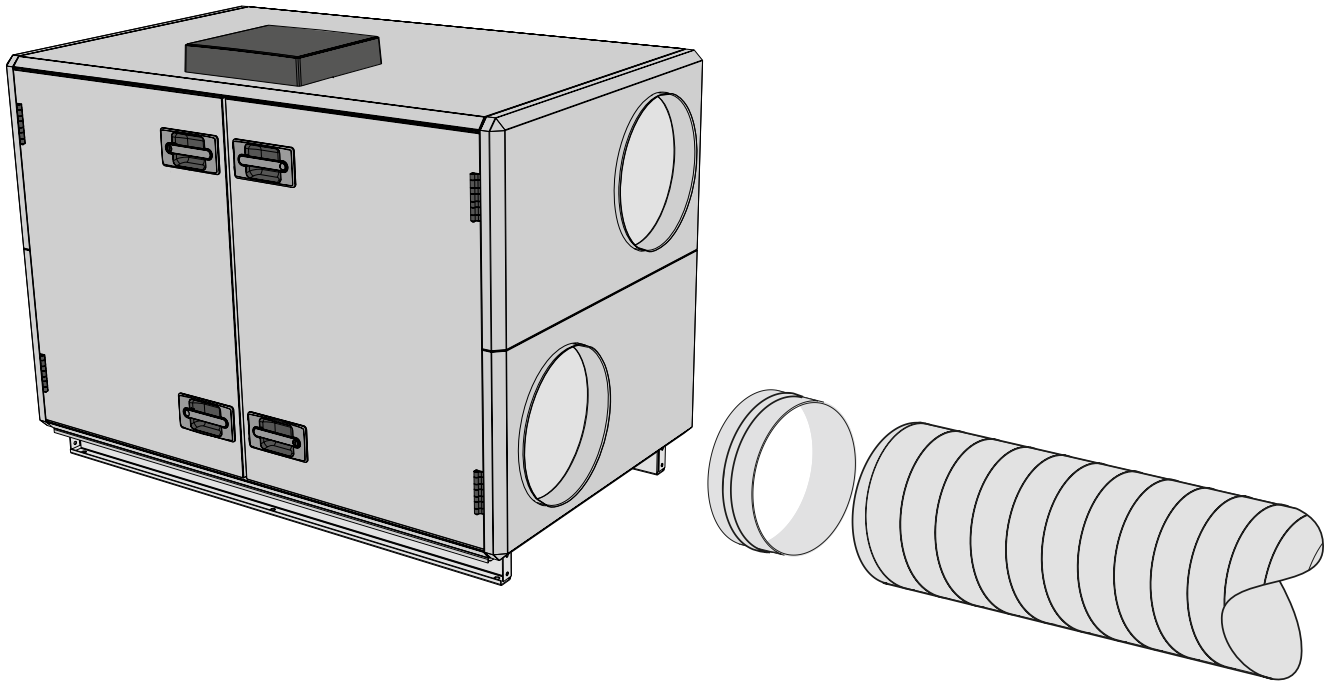

SILVER 004/005, 007/008, 011/012, 014/020, 014+/020+, 025/030, 025+/030+, 035/040, 040+, 050/060, 050+/060+, 070/080

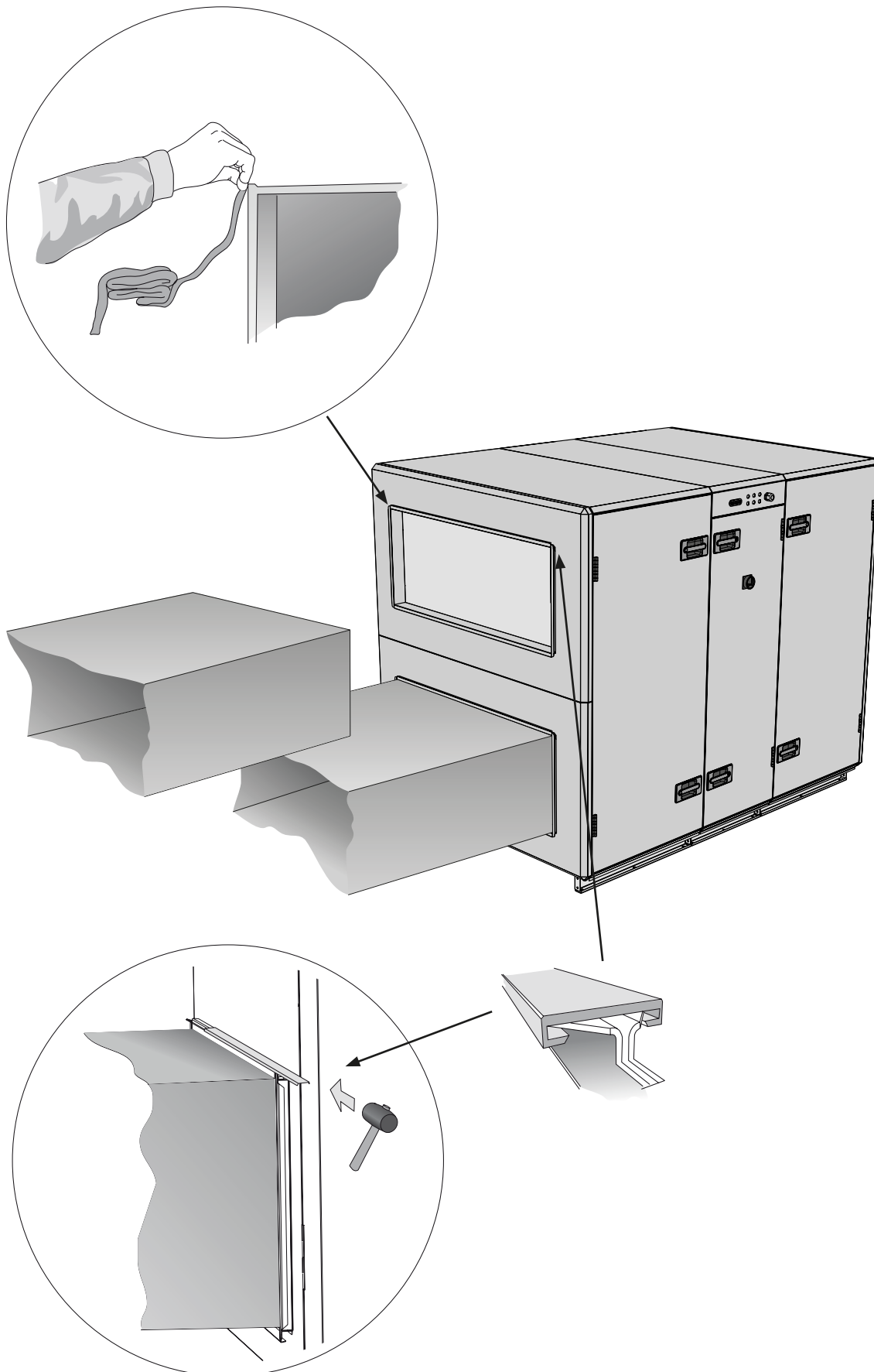

9.

EN - See special instructions for electrical connection of fan motors, heat exchanger controls, damper actuators etc.
SE - Se särskilda instruktioner för elektrisk anslutning av fläktmotorer, värmväxlarstyrning, spjällmotorer etc.
DK - Se separat vejledning til elektrisk tilslutning af ventilatormotorer, varmevekslerstyrning, spjældmotorer osv.
FI - Katso puhallinmoottorien, lämmösiirrinohjaimen, peltitoimilaitteiden jne. sähköliitännöjen erilliset ohjeet.

10.

SILVER RX 004/005, 007/008, 011/012, 014/020, 014+/020+, 025/030, 025+/030+, 035/040, 050/060, 070/080

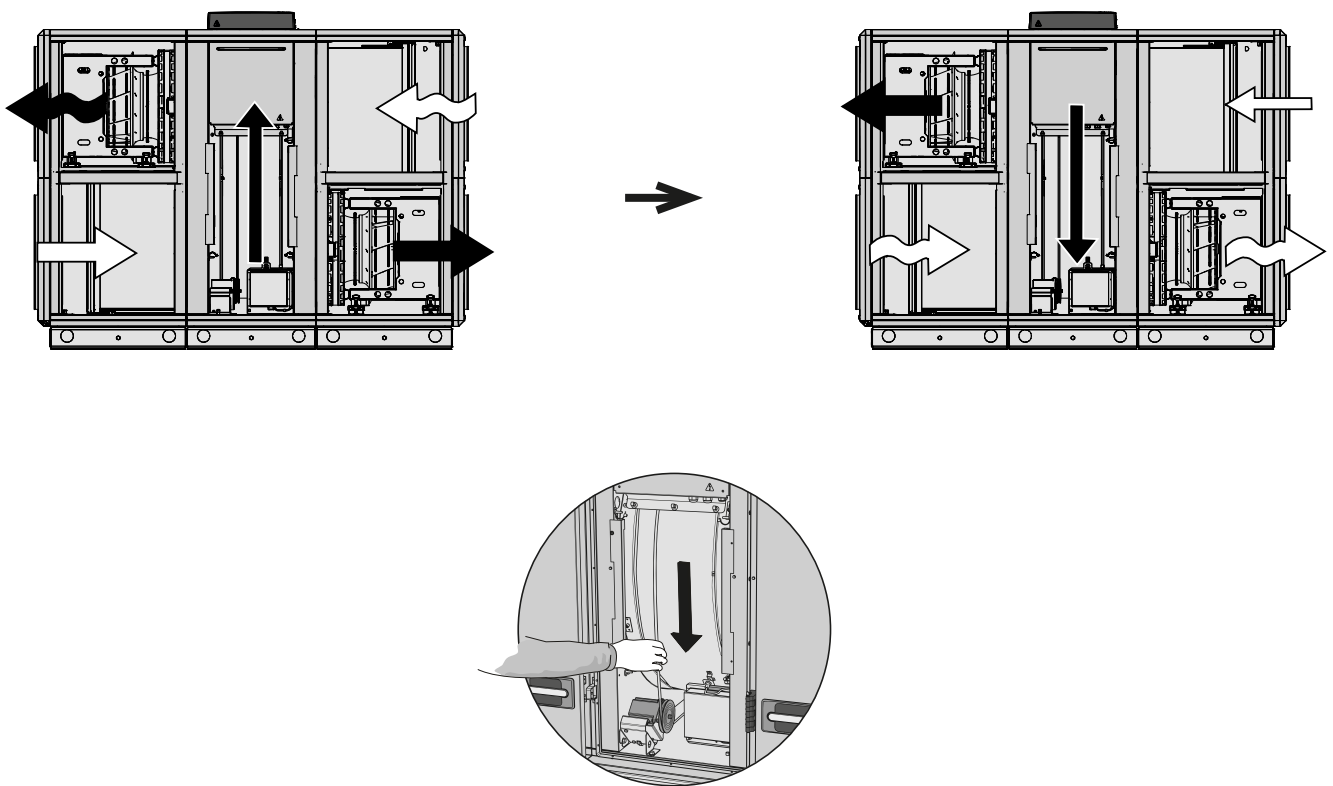

EN - See also special instructions for heat exchanger controls.
SE - Se också särskild instruktion för värmväxlarstyrning.
DK - Se også separat vejledning til varmevekslerstyrning.
FI - Katso myös erityisiä ohjeita lämmönvaihtimen ohjaukselle.

Feel good **inside**

