

Instructions heat exchanger control system, 2-8 Nm SILVER RX, RECOⁿomic, sizes 04-80+, RECO^sorptic, sizes 04-80+

1. General

The heat exchanger control system is a system for controlling motors 2 - 8 Nm. It is designed for precise and quiet control of rotary heat exchangers in SILVER RX ventilation units with standard rotor (RECOⁿomic) in sizes 04-80+, and with sorption rotor (RECO^sorptic) in sizes 04-80+.

The control system consists of a motor control system with an integrated rotation monitor and a motor. The rotation monitor is used for monitoring the rotor movement to ensure that the rotor rotates as intended.

The heat exchanger control system is designed for precise control of the rotor's rotation speed, which enables energy-optimum heat recovery.

The heat exchanger control system is located inside the centre section of the air handling unit. For access, open the inspection door.

Forbidden to start operation

It is absolutely forbidden to start operation until the entire air handling unit, where the above-mentioned heat exchanger control system is integrated, has been declared to conform to relevant regulations in Machinery Directive 98/37/EC and to existing national legislation, if applicable.

The heat exchanger control system must not be powered up until the entire installation conforms to the provisions in ALL relevant EU Directives.

If the heat exchanger control system has been damaged, for instance during transport, it must be inspected and repaired by qualified personnel before it is voltage fed.

Built-in protection

If the temperature in the heat exchanger control system exceeds 95 °C, the heat exchanger control system will attempt to reduce the heat development by reducing the amount of current fed to the motor.

The heat exchanger control system has a built-in current limiter to protect the motor and cables, which means it cannot deliver more current than it is set to.

The heat exchanger control system is short-circuit protected against phase-phase-short-circuiting on the unit's motor connector (U, V, W).



2. Technical data

Control

	Unit	Heat exchanger control system
Torque	Nm	2.0 / 4.0 / 8.0
Size based on capacity	W	55 / 110 / 220
Efficiency	%	> 90%
Power supply		
Voltage	VAC	1 x 230 V AC 50/60 Hz -15%/+15%
Supply current at maximum load	A	0.6 / 2.0 / 3.4
Power factor (cos-phi) at maximum load		0.65
Motor output		
Nominal motor output (on the shaft)	kW	55/110 / 220
Motor speed	rpm	0 - 200
Nominal torque, motor	Nm	2.0 / 4.0 / 8.0
Torque, motor boost	Nm	2.5 / 5.0 / 10.0
Frequency	Hz	0 - 400
Max. voltage out	Vrms	3 x 0 - 200 V AC
Protection		
Max. fuse protection	A	10
Output, motor		Short-circuit protected between phases
Motor		Current limitation protection
Impulse protection		Transient protection of VDR
Surge protection		No
overload protection		Overload protection, current and temperature
Environment		
Temperature, operation	°C	-40 to +40
Temperature, start	°C	-40 to +40
Temperature, storage	°C	-40 to +70
Dimensions	mm	183 x 143 x 55
Degree of protection	IP	54
Enclosure material		Plastic
Front cover		Plastic
Weight	kg	0.9
Relative humidity	% rh	10-95% RH, non-condensing
Cooling		Self-cooling
Interface		
RS-485 interface protocol		RS-485 interface (Baud rate: 9.6, 19.2, 38.4, 57.6, 115.2 kbaud) Preset: 38.4 kbaud, 2 stop bits, non-parity
RS-485 interface connection		2 x RJ12 & 3 x spring-type terminals
RS-485 interface cable		Max. 100 m
7-segment display		3
Analogue In1		0-10 VDC, 100% @ 9.5 V DC +/-2%
Analogue Out1		+10 V DC
Digital In1 (internal Pull up)		Alarm resetting
Digital In2 (internal Pull up)		Activation of external rotation monitor
Alarm relay		SPDT-relay 1 A 30 V DC/24 V AC
Green LED		On: Power connected Flashing: RS-485 interface communication
Red LED		Flashing: Alarm, but still operating Lit constantly: Serious alarm - stop the motor
DIP switches		4
Functions		
Technology		Sinusoidal back-EMF signal controlled via FOC (Field Oriented Control)
Ramp up time	sec.	60
Ramp down time	sec.	60
Alarm		Yes
Alarm resetting		Via digital input, RS-485 interface or by powering down the unit for more than 60 seconds
Air purging	sec.	Yes
Service data log		In-operation hours, alarm, load, program version, max. temp., max. motor voltage, max. motor current, max. ripple voltage, max. ripple current
Updating the software		Yes. via serial interface
Short-circuit protection		Yes
EMC filter		Integrated
Approvals		
EMC		EN 61800-3 (C1 & C2)
LVD		EN 61800-5-1
Product standard		EN 61800 Part 2
The RoHS Directive		Yes
Product approvals		CE

PBS: Data applies at: nominal supply voltage and at +25 °C ambient temperature

Drive motor

Three drive motors are used, see data in the table.

	Unit	Drive motor		
		55 W, 2 Nm	110 W, 4 Nm	220 W, 8 Nm
Size SILVER RX, standard rotor		04-08	11-40	50-80+
Size SILVER RX, sorption rotor		04-08	11-30	35-80+
Torque	Nm	2.0	4.0	8.0
Output	W	55	110	220
Weight	kg	≈ 2.4	≈ 3.5	≈ 5
Enclosure class	IP	54	54	54
Temperature, operation	°C	-40 to +45	-40 to +45	-40 to +45
Temperature, storage	°C	-40 to +70	-40 to +70	-40 to +70
Dimensions	mm	85 x 85 x 67	85 x 85 x 97	85 x 85 x 156

3. Function

General

The motor's linear torque curve permits very exact control of the rotor speed over a very large range. This results in energy efficient heat recovery and exact temperature control.

The heat exchanger control system is controlled with 0 – 10 V signals or via Modbus communication.

The combination of the motor's high torque and FOC technology (Field Oriented Controls) produces a unique innovative solution and increased efficiency. The unit uses the feedback signal from the motor to ensure that the motor receives exactly the right amount of current to reach the set speed and torque.

Rotation speed monitor

The heat exchanger control system is equipped with advanced software to monitor the rotor's rotation, which means that no physical or optical rotor protection is necessary.

4. Functions and settings

DIP switches

The heat exchanger control system is equipped with 4 DIP switches for setting e.g. motor size and maximum motor speed, see the table below.

The DIP switches are set at the factory as per the table below:

	DIP1	DIP2	DIP3	DIP4
Rotor, standard				
SILVER				
RX 004-008	OFF	OFF	OFF	OFF
RX 011-040	ON	OFF	OFF	OFF
RX 050-070	OFF	ON	OFF	OFF
RX 080/080+	OFF	ON	ON	OFF
Rotor, sorption				
SILVER				
RX 004-008	OFF	OFF	ON	ON
RX 011-030	ON	OFF	ON	ON
RX 035-080+	OFF	ON	ON	ON

Incorrect DIP switch setting for motor selection and maximal motor speed can result in inferior performance or overloading of the motor, with the risk of overheating and permanent damage to the motor and drive unit.

Testing

The heat exchanger control system is equipped with a test function in the form of a built-in test button.

The test button is placed inside the drive unit in the top right corner and must be used with the drive unit open.

The test button has different functions depending on how long the button is pressed in:

1. Short press <1 sec.: The drive unit enters test mode and stops in test mode until the button is pressed again. The rotor will start to rotate in a sequence from 0–100 rpm according to the selected ramp up time and remain at 100 rpm. Press the button again to exit test mode and stop the rotor according to the set ramp down time.

2. Press and hold the button to put the drive unit in test mode, where it remains until the button is released. The signal to the rotor changes to 100 rpm according to the set ramp up time.

The test button also works when the RS-485 interface control is enabled.

Note that when you press the test button for more than 20 seconds the calibration function for the internal rotor protection is enabled, see the section Test and calibration of the internal rotor protection.

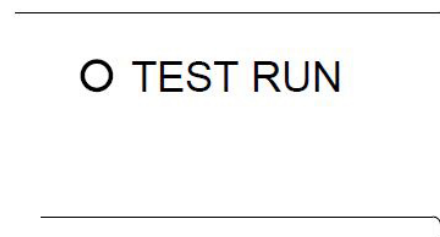
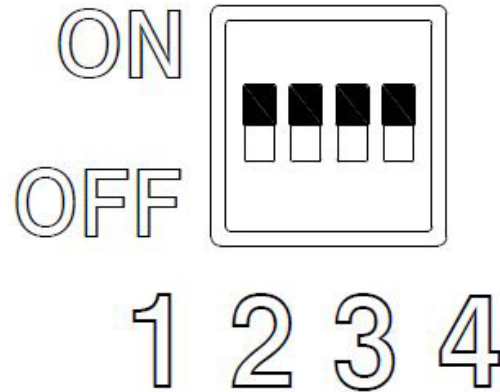

LED indicator

The heat exchanger control system is equipped with a LED indicator, see the diagram to the right.

The LED is visible with both an open and closed casing.

LED indicator codes, see the table below.

LED Status	Status
OFF	No voltage
Green ON	Powered up
Flashing green	Valid RS-485 interface communication
Red ON	Rotor stopped due to a critical alarm
Flashing red	Operational with reduced capacity
Orange ON	Test function enabled
Flashing orange	Purging function enabled

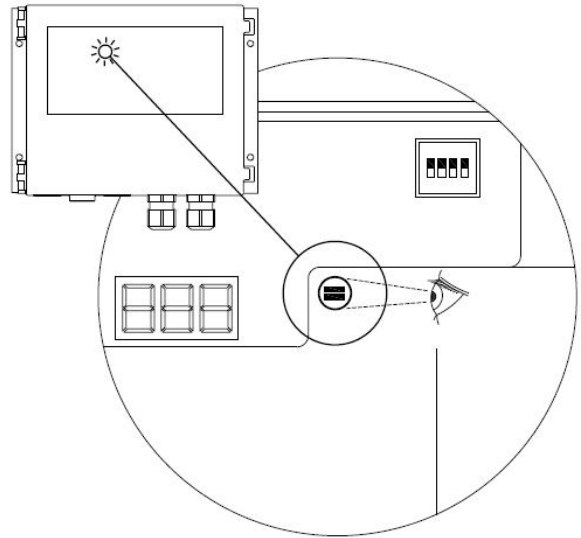

Display

The display is visible with the casing open or closed.

The display shows the current status for the drive unit, motor and rotor, see the table below.

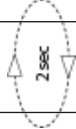
139		The current motor speed is shown when the motor is running and no diameter has been specified for the rotor or belt pulley via each corresponding RS-485 interface register.
12		Current torque (Nm) The display switches between torque and speed with a 2 second changeover interval.
E 12		Error codes: see the significance of individual error codes in the section "Alarms and error codes".
de		Reduced performance due to overloading, overheating or another error or overload. Read the current error/ alarm via the RS-485 interface.
PU		Purging function enabled
EST		The test function is enabled and the motor receives the control signal for maximum speed rotation.
SEP		Motor is in "STOP" mode

0 - 10 V control

The heat exchanger control system is set at the factory for 0-10 V control.

This can be changed to constant RS-485 interface control, see the section RS-485 interface control below.

The motor starts when there is a control signal above 1.1 V (see the diagram to the right).

The motor stops when the control signal is lower than 0.6 V (see the diagram to the right).

The motor runs at maximum speed when there is a control signal above 9.5 V (see the diagram to the right).

Compensation for non-linear heat transfer on the rotor can be achieved by configuring a K-factor. It is thus possible to achieve a significantly more optimal heat transfer and an improved setting (see the diagram to the right).

The K-factor is configured via the RS-485 interface register.

The default K-factor is configured by the manufacturer to 50.

RS-485 interface control

The heat exchanger control system can be controlled via Modbus commands according to the Modbus protocol (see separate document)

If a signal is received via the RS-485 interface in the start register, and/or speed register the drive unit will temporarily switch from 0–10 V control to RS-485 interface control until the next restart.

If the heat exchanger control system is to be controlled via the RS-485 interface, the Coil Stat Bit register 8 must be set to "0" = "RS-485 interface control", see the RS-485 interface protocol.

Monitoring of alarms and status can still be performed via the RS-485 interface, even if "RS-485 interface control" is not enabled.

Rotation monitoring

When the motor and rotor are mechanically connected via a drive belt, it is necessary to monitor whether the rotor rotates.

The heat exchanger control system is equipped with internal rotor monitoring.

If the motor no longer drives the rotor due to a slack or defective belt, the heat exchanger control system will trip an alarm for "rotor protection".

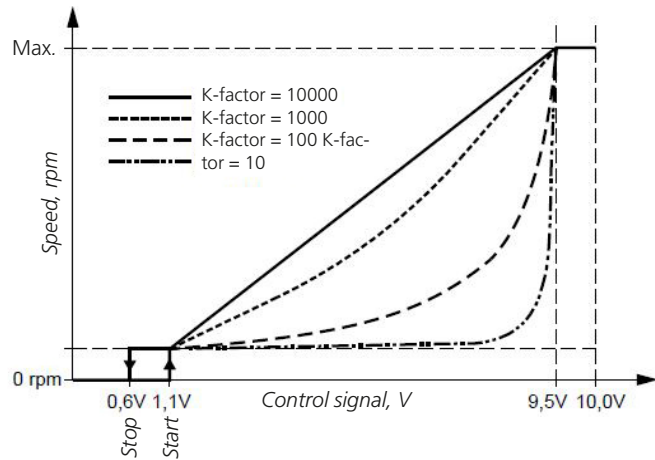

Internal rotor protection

The internal rotor protection monitors the correct direction of rotation of the rotor by measuring the motor current and motor speed.

The rotation control software checks every 10 seconds changes in the motor speed after a brief change of the motor current. In the event of six unsuccessful checks, a restart is tripped.

The default setting in the heat exchanger control system is one restart attempt. After approximately two minutes, a rotor protection alarm sounds.

The internal rotor protection works automatically at a speed over 25 rpm. At motor speeds below 25 rpm, typically the connected control unit (AHU control unit) assists. If the rotor does not provide the required heat recovery, the connected control unit will request a higher speed to enable higher heat recovery.

Boost function

The heat exchanger control system has an integrated "Start function" that automatically makes a higher current intensity to the motor during start possible.

The heat exchanger control system can deliver up to 150% of the nominal current (stated in mA) to the motor during start (max. 100 sec.)

The heat exchanger control system stops the start function when the set "start time" on the timer elapses or when the motor has reached 50% of the maximum set speed.

Purging

When the heat exchanger control system is set to "RS-485 interface" purging is controlled from the air handling unit's control system.

When the heat exchanger control system is controlled via the 0–10 V-signal, purging starts automatically when the motor has been switched off for 10 minutes.

The motor will run a number of revs at low speed, after which the motor stops again.

The function is repeated every 10 minutes when the motor is switched off.

The function thereby prevents mechanical faults and soiling of the rotor.

Display of the actual speed

During normal operations the drive unit's display will show the speed of the motor or rotor.

Built-in protection

If the temperature in the heat exchanger control system exceeds 95 °C, the heat exchanger control system will attempt to reduce the heat development by reducing the amount of current fed to the motor.

The heat exchanger control system has a built-in current limiter to protect the motor and cables, which means the heat exchanger control system cannot deliver more current than it is set to.

The heat exchanger control system is short-circuit protected against phase-phase-short-circuiting on the unit's motor connector (U, V, W).

The heat exchanger control system's control inputs are protected against short-circuiting.

Blocked rotor detection

If the rotor load is higher than the nominal maximum torque for the heat exchanger control system and the motor, the heat exchanger control system will trip an alarm for blocked rotor.

This detection depends on the belt tension and the friction between the belt and belt pulley.

A significantly lower belt tension will be perceived as a failed belt and trip the alarm for the internal rotor protection, which results in the heat exchanger control system stopping the motor.

A lower belt tension can reduce the friction between the belt and belt pulley and can cause a lower rotor speed than required if the belt slips on the belt pulley.

Depending on the motor's speed and friction between the belt and belt pulley, the heat exchanger control system will detect this failure through monitoring the motor's creep speed and system vibrations.

High creep values and vibrations will typically be detected at higher motor speeds.

Test and calibration for internal rotor protection

1. Switch off the heat exchanger control system and remove the belt from the belt pulley.
2. Switch on the heat exchanger control system and briefly press the test button > 1 second to start test mode.
3. The LED lights orange.
4. Wait until the motor reaches maximum speed (limited to 100 rpm).
5. Once the motor has reached maximum speed, the system will start to perform the internal rotor protection function. The motor will accelerate at short intervals every 10 seconds (which should be audible).
6. If the motor stops and restarts after one minute, the internal rotor protection is calibrated correctly. Press the test button for 2 seconds to exit test mode.
7. If the motor continues to run for more than a minute, calibration needs to be performed.
8. How to recalibrate: Press and hold the test button (10–20 sec.) until the LED flashes orange.
9. After recalibration you can switch off the heat exchanger control system and refit the belt.

5. Electrical connections

Electrical connections must be carried out by a qualified electrician.

Open the heat exchanger control system

Make sure the supply voltage is disconnected before opening the front casing.

Wait about 3 minutes after disconnecting the mains voltage before opening the front casing.

The heat exchanger control system is opened using a screwdriver or the like, see figure to the right.

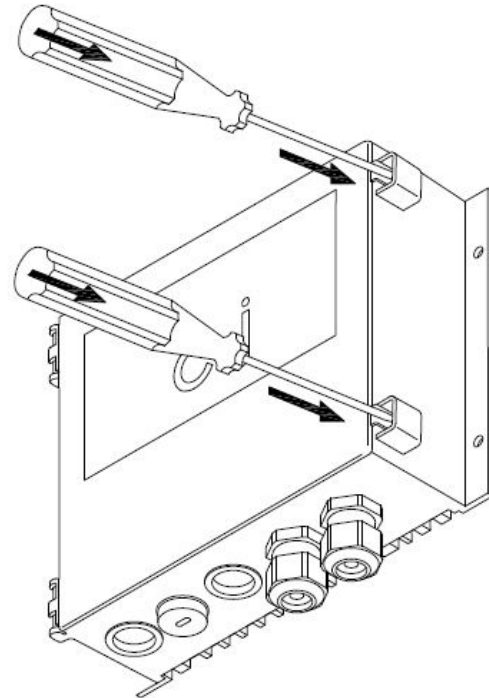

Overview, terminals and connectors

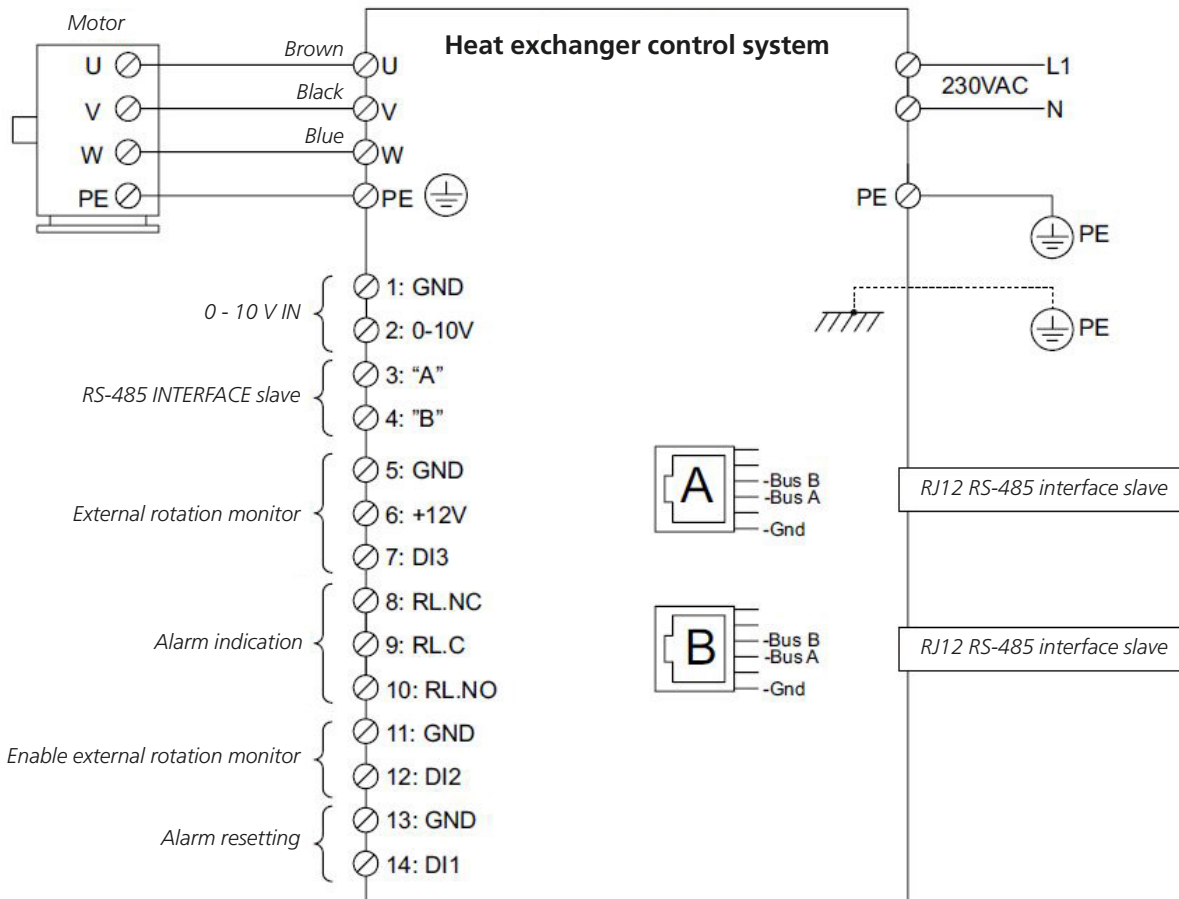

Supply connection

Power supply 230 V AC, +/-15%.

The power cable is connected to the heat exchanger control system on terminals "L", "N" and "PE", see the figure to the right.

It is recommended that the PE wire is 20 mm longer than the other wires in the cable.

Remember to tighten the cable glands to ensure moisture cannot enter the heat exchanger control system and to provide strain relief.

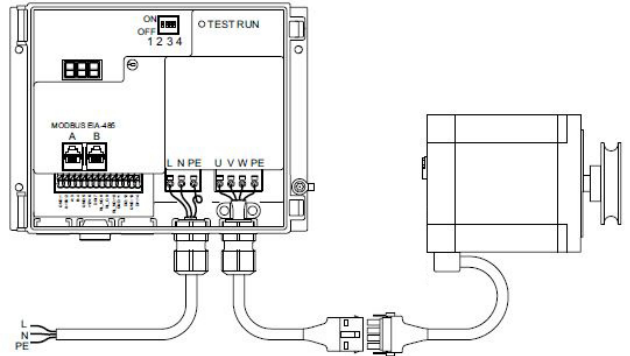

Control 0 - 10 V

Analogue 0-10 V input control signal for speed control via external 0-10 V control signal.

For potentiometers, use +12 V DC output on pin 6 for 0-10 V input on pin 2, see the figure to the right.

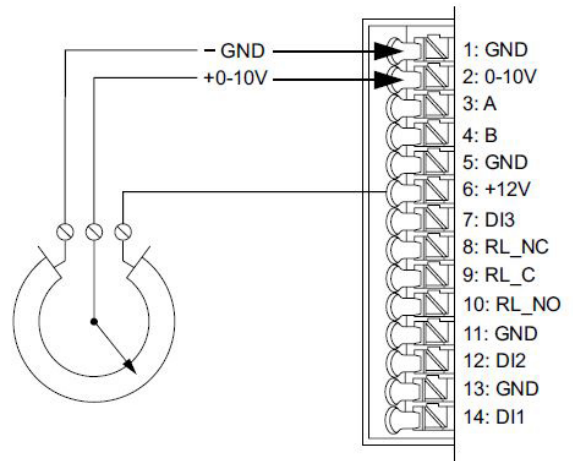

Control via Modbus

The RS-485 Interface can be connected to the heat exchanger control system via the two RJ12 connectors or via the spring terminals in the terminal block.

If RJ12 connectors are used a telecom cable, 6-wires, unshielded, 30 AWG/0.066 mm² (flat/telecom cable) is recommended.

When fitting the RJ12 connectors, note that the connectors must be directed so that the colour sequence in the connectors are the same at both ends, see the figure to the right.

The RJ12 connectors in the heat exchanger control system are marked MODBUS EIA-485 "A" and "B", see the figure to the right.

Connectors "A" and "B" are connected in parallel internally and it is therefore optional which connector is used.

Same colour sequence

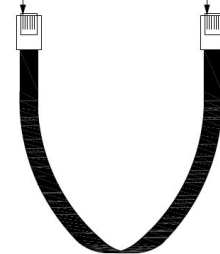

MODBUS EIA-485

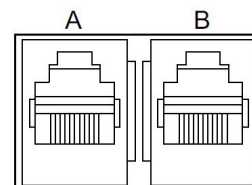

6. Modbus

On delivery the heat exchanger control system is set at the factory as per the table below:

	Setting range	Unit	Factory setting
Address	1-247		79 dec.
Baud rate	9.6, 19.2, 38.4, 57.6, 115.2 kBaud		38.4
Parity	None, even, odd		None
Stop bit(s)	0, 1, 2		2
Communication, timeout	0-240	Sec.	10

The heat exchanger control system supports commands according to the table below:

Function code	Description
1	Read Coil Status
2	Read Input Status
3	Read Holding Registers
4	Read Input Registers
5	Force Single Coil
6	Preset Single Registers
8	Diagnostics. Sub-function 00 Only – Return Query Data (loop back)
15	Force Multiple Coils
16	Preset Multiple Registers

Detection of enabled Modbus

The heat exchanger control system automatically detects valid Modbus communication on Modbus inputs (RJ12 connector or "A" and "B" on the terminal block).

The heat exchanger control system will first detect the communication parameters: ID 79, 38.4 – 8 – N – 2

Alternative communication parameters can be set with the help of the Modbus register.

After 10 seconds without a valid Modbus request being received with standard parameters, the heat exchanger control system will attempt to detect a Modbus request with the alternative parameters.

Modbus protocol

The current Modbus protocol can be downloaded from www.swegon.com

7. Trouble shooting

Control 0 - 10 V

Symptoms	Cause	Action
The motor doesn't run	There is no power supply	Check the supply voltage (230 V AC) to the heat exchanger control system terminals "L" and "N" (nominal supply voltage is specified on the rating plate). The LED lights with a constant green light – see section 15.3 for additional LED indications.
		Check if the short-circuit protection is activated.
		Check that other components have not disconnected the supply voltage to the heat exchanger control system.
	Bad electrical connections	Check the electrical connections.
	Incorrect motor to the heat exchanger control system	Check that the DIP switch is set correctly for the selected motor size and speed.
	No control signal 0-10 V DC	Check that the heat exchanger control system receives a signal >1.1 V on "0-10 V In".
	Active alarm	Read active alarms via the display, RS-485 interface register or with the heat exchanger control system PC-tool and remove the cause of the alarm.
	The motor has been stopped by the built-in motor protection due to an overload or other alarm	Reset the alarm by short-circuiting the "Alarm reset" input. The alarm can also be reset by switching off the supply voltage to the heat exchanger control system and switching it back on after about 60 seconds.
Defective heat exchanger control system	Replace the heat exchanger control system. Never attempt to repair a defective heat exchanger control system. Contact your supplier for replacement/repair.	
Defective motor	Replace the motor	
The motor runs in the wrong direction	Incorrect phase sequence in motor cable	Switch the 2 phase wires on the heat exchanger control system's motor terminals.
	RS-485 interface register set incorrectly	The direction of rotation can also be inverted via an RS-485 interface command.
The heat exchanger control system stops due to an alarm	At least one active alarm	Via the display, RS-485 interface read the alarm and establish which alarm has stopped the motor.
		Reset the alarm by short-circuiting the "Alarm reset" input. The alarm can also be reset by switching off the supply voltage to the heat exchanger control system and switching it back on after about 60 seconds.
	The alarm is shown again after resetting	Rectify the cause of the alarm reactivation.
The rotor stops unintentionally (error code: E01, display version)	Internal rotor protection detects a loose or defective belt	Adjust or replace the belt
	The internal rotor protection is calibrated incorrectly (see 15.8 for more information)	Perform a recalibration

Control via RS-485 interface

Symptoms	Cause	Action
The motor doesn't run.	There is no power supply	Check the supply voltage to the heat exchanger control system terminals "L" and "N" (230 V AC)
		Check if the short-circuit protection is activated.
		Check that other components have not disconnected the supply voltage to the heat exchanger control system.
	Bad electrical connections	Check the electrical connections.
	Incorrect motor to the heat exchanger control system	Check that the DIP switch is set correctly for the selected motor size and speed.
	There is no in-operation signal	Check that the heat exchanger control system can receive operation signals. Coil Stat Bits Register 0X0001: Start/stop for motor (1=on)
	No %-control signal from Modbus-RS-485 interface	Check the RS-485 interface control signal on the RS-485 interface address: Holding registers; Register 3X0001: PrcSet 0-10000 (0-100%)
	The motor has been stopped by the built-in motor protection due to an overload	Reset the alarm: Coil Stat Bits Register 0X0002: Reset (1 pulse = resetting). The alarm can also be reset by switching off the supply voltage to the heat exchanger control system and switching it back on after about 60 seconds.
Defective heat exchanger control system	Replace the heat exchanger control system Never attempt to repair a defective heat exchanger control system. Contact your supplier for replacement/repair.	
Defective motor	Replace the motor	
The motor runs in the wrong direction	Incorrect phase sequence in motor cable	Switch the 2 phase wires on the heat exchanger control system's motor terminals.
	RS-485 interface register set incorrectly	The direction of rotation can also be inverted via an RS-485 interface command.
The heat exchanger control system stops due to an alarm	At least one active alarm	Via the display*, RS-485 interface read the alarm and establish which alarm has stopped the motor.
		Reset the alarm by short-circuiting the "Alarm reset" input. The alarm can also be reset by switching off the supply voltage to the heat exchanger control system and switching it back on after about 60 seconds.
	The alarm is shown again after resetting	Rectify the cause of the alarm reactivation.
The rotor stops unintentionally (error code: E01, display version)	Internal rotor protection detects a loose or defective belt	Adjust or replace the belt
	The internal rotor protection is calibrated incorrectly	Perform a recalibration

8. Alarms and error codes

The heat exchanger control system has built-in alarm monitoring that monitors optimal problem-free operations and trips an alarm for operating or performance problems.

The alarm is either a "critical" alarm or "non-critical" alarm.

"Critical" alarms stop the motor.

"Non-critical" alarms reduce the motor's performance.

The built-in alarm monitoring stops the heat exchanger control system.

If the alarm situation passes, the alarm is reset automatically and the heat exchanger control system restarts.

The alarm can be reset with a RS-485 interface command.

The alarm is reset automatically when the power is disconnected for longer than 60 seconds.

Alarm/error code is shown on the display.

Alarms can be read via Modbus, see Modbus protocol.

Overview of alarms/error codes, see the table below:

Error code	Alarm overview	Alarm overview	Activity
E01	Rotation monitor alarm	"C"	"SA5"
E02	Supply voltage too high	"C"	"SA5"
E03	Supply voltage too low	"C"	"S"
E04	The current to the motor critically increased, e.g. short-circuit in cable, connectors or motor	"C"	"SA5"
E05	Internal temperature in the heat exchanger control system too high (> 95 °C)	"NC"	"RP"
E06	Blocked motor	"C"	"SA5"
E07	No valid RS-485 interface communication >10 sec.	"C"	"S"
E08	Phase error on motor's power supply (U, V, W)	"C"	"SA5"
E09	Internal hardware failure	"C"	"S"

Alarm codes can be read on the display.

Notes:

"C" = critical alarm "NC" = non-critical

"RP" = reduced performance

"SA5" = the motor stops after a restart caused by the same error within 60 minutes

"S" = the motor stops immediately

9. Maintenance

Under normal operating conditions and load profiles, the heat exchanger control system is maintenance-free.

10. Approvals and certificates

CE marking

Swegon hereby declares under sole responsibility that the product complies with the following directives from the European Parliament:

LVD – low voltage: 2014/35/EU

EMC – electromagnetic compatibility: 2014/30/EU

RoHS – restriction of the use of certain hazardous substances in electrical and electronic equipment: 2011/65/EU

Product standard

In accordance with EN 61800-2 – Adjustable speed electrical power drive systems, general requirements.

Safety

In accordance with EN 61800-5-1 – Adjustable speed electrical power drive systems: Safety requirements – electrical, thermal and energy.

EMC – electromagnetic compatibility

In accordance with EN 61800-3 (C1 and C2) - adjustable speed electrical power drive systems. Part 3. EMC requirements and special testing methods.

RoHS compliant

Contains no hazardous substances in accordance with the RoHS directive.