

Product manual

---

# ThermShield FD EIS Classified Fire Damper

---

Fire protection

Version 3.0  
Issue Date: 10.03.2026.

- ▼ [PRODUCT OVERVIEW](#)
- ▼ [DIMENSIONS](#)
- ▼ [INSTALLATIONS](#)
- ▼ [ACTUATORS](#)
- ▼ [ACCESSORIES](#)
- ▼ [REPLACEMENTS](#)
- ▼ [MAINTENANCE AND OPERATION](#)

1. Flange
2. Gypsum layers
3. Intumescent joint
4. Contact layer
5. Cold smoke seal

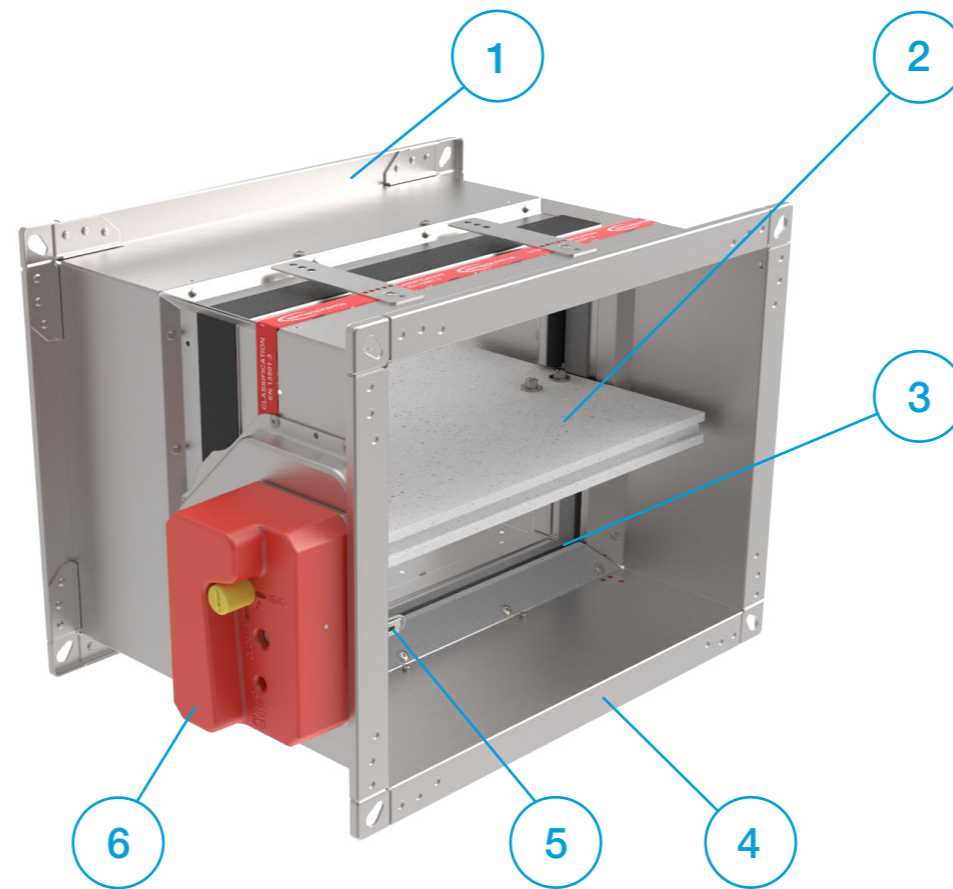
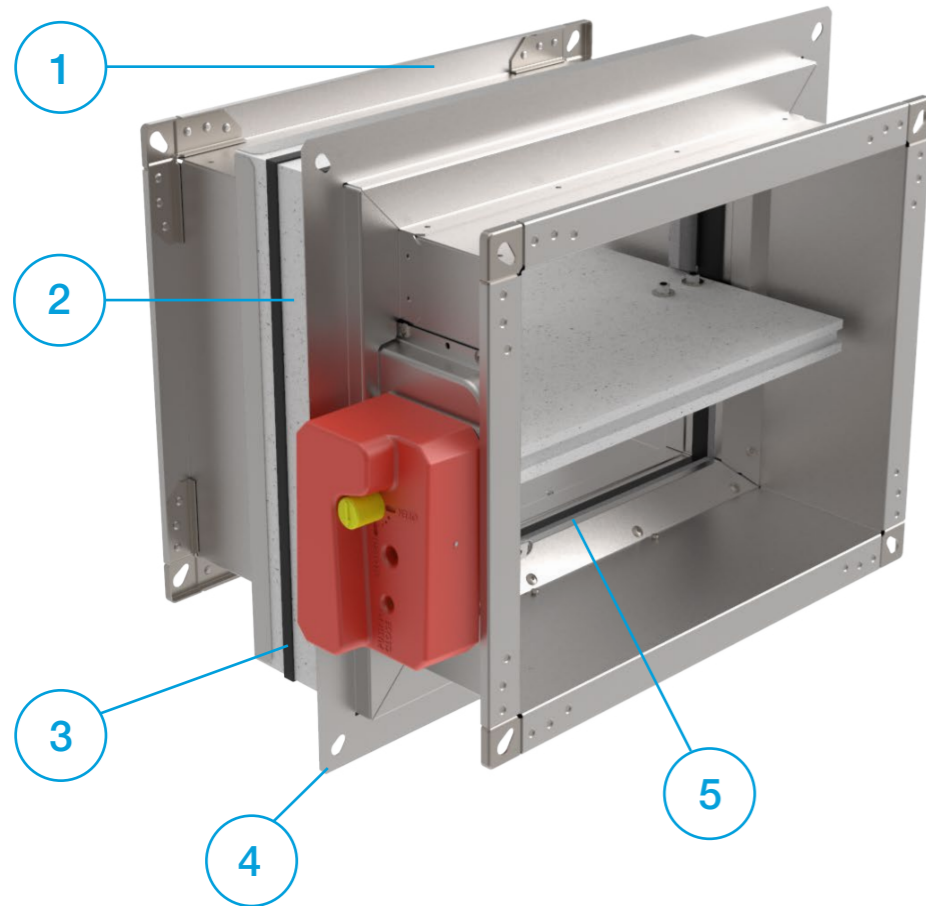

1. Galvanized steel casing
2. Fire resistant damper blade
3. Intumescent joint
4. Connection flanges
5. Thermal fuse
6. Actuator

## FIRE DAMPER - FD

### PRODUCT OVERVIEW

Fire dampers FD are used for prevention of fire spread through the ventilation ducts and between fire sections. Fire dampers consist of steel sheet case, calcium silicate damper blade, damper blade mechanism outside of the airflow and a manual, electromagnetic or electric actuator.

Fire damper case is made out of galvanized steel sheet. Variants produced from stainless steel and powder coated steel are also available. Calcium silicate blade is equipped with brass bearings and seals made out of polyurethane and elastomer rubber.

Fire dampers FD25 are produced up to size 800x600 and have 25 mm thick damper blade. Fire dampers FD40 are produced in sizes 800x600 up until 1500x800 and have 40 mm thick damper blade.

FD25 fire dampers are equipped with R25 manual mechanism and FD40 fire dampers are equipped with R40 manual mechanism.

Manual spring return mechanism is equipped with thermal fuse that is triggered automatically when the temperature inside the duct reaches 72 °C. It can also be activated manually by the push of the button on the mechanism ([see page 67.](#))

Additional equipment for manual mechanism include end contact switches for damper position signalling. Electromagnetic actuators feature spring return mechanism with electromagnet for remote activation. Additional equipment for electromagnetic mechanism include end contact switches for damper position signalling. Rearming of the electromagnetic actuator is manual.

Fire dampers with electric actuators are equipped with Belimo actuator drives in 24 V or 230 V versions. Activation of fire dampers equipped with electric drives can be via 72 °C or 95 °C thermal fuse or remotely via control signal. Rearming of the electric fire damper can also be done remotely via control signal. All electric actuators are equipped with end switches for position signalling.

ATEX rated versions of fire dampers can be delivered with Schischek 24 V / 230 V electric actuators that are rated for installation in explosive atmosphere areas.

All fire dampers are tested according to the EN 1751 for airtightness and retain class 3 leakage on the closed damper blade and class C on the casing air leakage.

\* The images shown are for illustration purposes only and may not be an exact representation of the product.

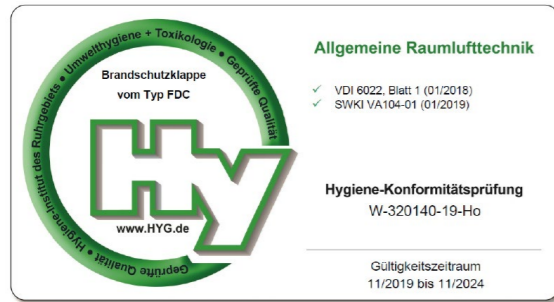

- ▼ [PRODUCT OVERVIEW](#)
- ▼ [DIMENSIONS](#)
- ▼ [INSTALLATIONS](#)
- ▼ [ACTUATORS](#)
- ▼ [ACCESSORIES](#)
- ▼ [REPLACEMENTS](#)
- ▼ [MAINTENANCE AND OPERATION](#)



## TESTS AND CERTIFICATES

All our dampers are submitted to a number of tests by official test institutes. Reports of these tests form the basis for the approvals of our dampers. Klimaoprema fire dampers are also suitable for installation in buildings with high hygienic demands such as hospitals, clinics and pharmaceutical areas.

To confirm this, our products are tested in independent Institute of Hygiene, based in Gelsenkirchen, Ruhr, and comply with directives and guidelines in VDI 6022.

Our FD damper contains an EPD certificate. EPD or Environmental Product Declaration is a document that transparently communicates the performance or impact on the environment of any product or material during its lifetime. The EPD is usually valid for five years and is produced according to the relevant standards. The EPD is made in accordance with EN 15804+A2 & ISO 14025/ ISO 21930.

## FIRE RESISTANCE CLASSIFICATION

FD fire resistance is tested according to EN 1366-2 "Fire resistance tests for service installations- Part 2: Fire dampers". Classification of the fire dampers is defined according to EN 13501-3 Fire classification of construction products and building elements.

Installation in both, vertical and horizontal axis of rotation of the dampers blade is acceptable (with the axis in vertical or horizontal).

Fire resistance of fire damper depends on classification of walls or ceilings. It is allowed to install products to walls or ceilings only according to products Declaration of Performance. Walls or ceilings with greater fire resistance can also be used. Fire damper should be installed according installation manual which can be found within this document.

Please consult latest Declaration of Performance on our website:

For more information about certificates, visit our website.

- E** - Integrity
- I** - Insulation
- 120/90/60** - Classification time in minutes
- S** - Smoke leakage
- ve** - Damper installed in vertical compartment
- ho** - Damper installed in horizontal compartment
- i↔o** - Fire performance criteria are met on both sides



## TECHNICAL DATA

Fire damper casing is manufactured from galvanized steel sheet, but on demand can be produced out of:

- Galvanized steel and powder coated
  - Stainless steel EN 1.4404 (AISI 316L), EN 1.4301 (AISI 304)
  - Stainless steel EN 1.4404 (AISI 316L), EN 1.4301 (AISI 304) and powder coated
- \*\* **Stainless steel not possible with MF1, MF2, Applique**

Fire damper for areas with potentially explosive atmospheres are also available

CLASS C EN1751

**actionair**  
by Swegon

USER MANUALS 

1		<b>SERIAL NUMBER:</b>	201112600300001	
	2	<b>PRODUCTION DATE</b>	11.03.2022	
3	4	<b>TYPE:</b>	FD25 – 400x250 – M230 – S	
5	6	<b>DIMENSION:</b>	400x250x350	<b>LOCATION:</b>
7	8	<b>ACT. MECHANISM:</b>	M230	<b>IP PROTECTION:</b> IP54
8		<b>NOMINAL VOLTAGE:</b>	AC 230V	<b>FREE SPACE (dm2):</b> 6.66
		<b>SIGNALISATION</b>	Yes	<b>THERMAL FUSE:</b> 72°C

EN15650:2010

1812-CPR-1162







For fire classification of product consult declaration of performance.

DOP 710

EI60/90/120 (Ve Ho i < - > o)S 500Pa

**PRODUCT MUST BE INSTALLED BY INSTRUCTIONS SUPPLIED BY MANUFACTURER**

  
201112600300001

-  [PRODUCT OVERVIEW](#)
-  [DIMENSIONS](#)
-  [INSTALLATIONS](#)
-  [ACTUATORS](#)
-  [ACCESSORIES](#)
-  [REPLACEMENTS](#)
-  [MAINTENANCE AND OPERATION](#)



PRODUCT OVERVIEW

FIRE DAMPER - FD

### Rating plate

- 1 - Casing air leakage classification
- 2 - Serial number
- 3 - Production date
- 4 - Type
- 5 - Dimension of the fire damper
- 6 - Mechanism type
- 7 - Nominal voltage
- 8 - Signalisation (end contacts)
- 9 - IP protection
- 10 - Free space
- 11 - Thermal fuse temperature
- 12 - Number of the European standard and year of its publication
- 13 - Declaration of performance
- 14 - Classification according to EN 13501-3
- 15 - Barcode

### Product specifications

Nominal sizes FD25	100x200 - 800x600 [mm]
Nominal sizes FD40	800x600 - 1500x800 [mm]
Casing length	350 mm
Temperature range	-20 °C ... 50 °C
Release temperature	72 °C (standard) or 95 °C (optional with electric actuator)
Volume flow rate range	up to 20.700 m³/h
Differential pressure ranges	up to 1.000 Pa
Casing air leakage	Class C, EN 1751
Closed blade air leakage	Class 3, EN 1751
Upstream velocity	< 12 m/s
EC conformity	EN 13501-3, EN 1366-2, EN 15650, EN 1751, CPR no.305/2011
Declaration of performance	DoP 710

## MODELS

### Casings

#### FD25

Fire damper with 25 mm damper blade and fire classification up to EI120S. Sizes range from 100x200 till 800x600.

#### FD40

Fire damper with 40 mm damper blade and fire classification up to EI120S. Sizes range from 800x600 till 1500x800.

#### FD25 - APP

Fire damper with integrated Applique installation kit with 25 mm damper blade and fire classification up to EI90S. Sizes range from 100x200 till 800x600.

#### FD25 - MF1

Fire damper with integrated MF1 installation frame with 25 mm damper blade. Sizes range from 100x200 till 800x600.

#### FD25/FD40 - MF2

Fire damper with integrated MF2 installation frame with and fire classification up to EI90S. Sizes range from 100x200 till 1500x800.

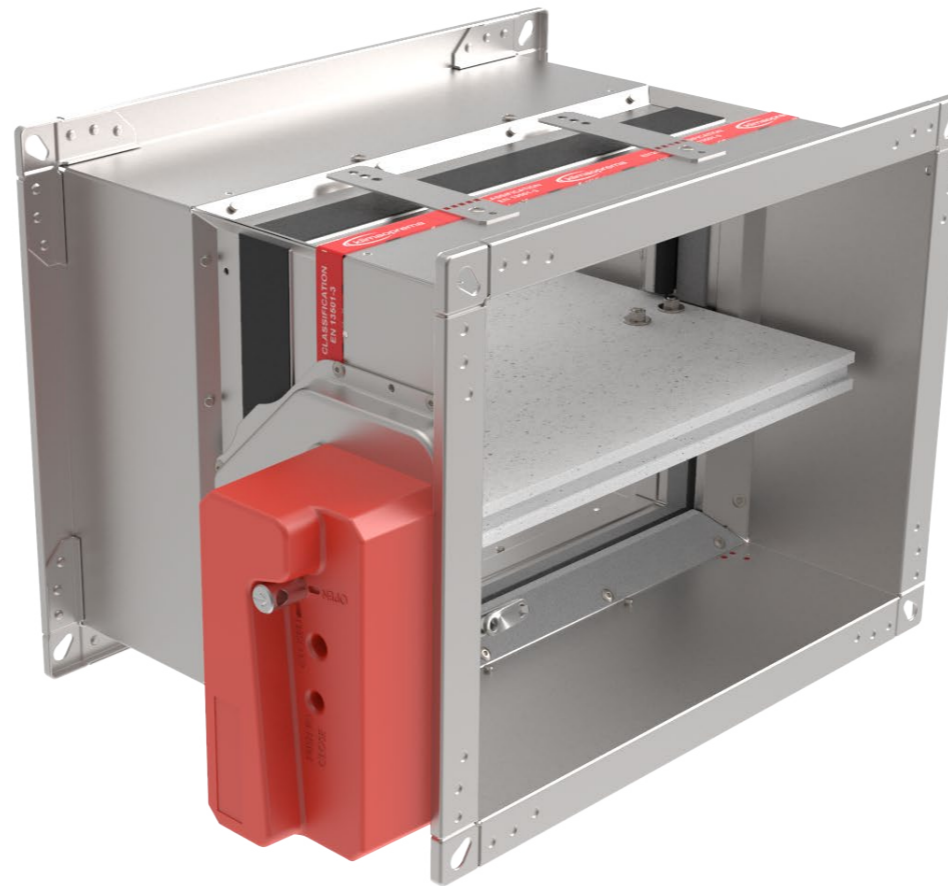

- ▼ [PRODUCT OVERVIEW](#)
- ▼ [DIMENSIONS](#)
- ▼ [INSTALLATIONS](#)
- ▼ [ACTUATORS](#)
- ▼ [ACCESSORIES](#)
- ▼ [REPLACEMENTS](#)
- ▼ [MAINTENANCE AND OPERATION](#)



PRODUCT OVERVIEW

FIRE DAMPER - FD

## Actuators

### R (R-S)

Manual operating mechanism, optionally with end switches (R-S). In case of fire, the fire damper closes automatically. Damper closing can be initiated either by thermal fuse melting, or by manual activation on the operating mechanism. Upon closure, damper blade is locked in closed position and can only be opened manually (see page 63.). Thermal fuse melting point is 72 °C.

### EMS-S

Electromagnetic operating mechanism, comes with end switches as standard. In case of fire, the fire damper closes automatically. Damper closing can be initiated either by thermal fuse melting or remotely by triggering the electromagnet. Electromagnet is constantly under power and activates closing of the damper blade in case the power cuts out. Upon closure, damper blade is locked in closed position and can only be opened manually (see page 63.). Thermal fuse melting point is 72 °C.

### M230-S/M230-S-ST

Belimo 230 V electro motor operating mechanism, comes with integrated end switches. In case of fire, the fire damper closes automatically. Damper closing can be initiated either by thermoelectric release device or remotely by triggering the electro motor. Upon closure, damper blade is locked in closed position and can be opened by sending a signal to electro motor. Standard thermoelectric release point is 72 °C, optional 95 °C. M230-S-ST actuator is additionally equipped with connection plug for easy connection with power supply and communication modules.

### M24-S

Belimo 24 V electro motor operating mechanism, comes with integrated end switches. In case of fire, the fire damper closes automatically. Damper closing can be initiated either by thermoelectric release device or remotely by triggering the electro motor. Upon closure, damper blade is locked in closed position and can be opened by sending a signal to electro motor. Standard thermoelectric release point is 72 °C, optional 95 °C.

### M24-S-ST

Belimo 24 V electro motor operating mechanism, comes with integrated end switches. In case of fire, the fire damper closes automatically. Damper closing can be initiated either by thermoelectric release device or remotely by triggering the electro motor. Upon closure, damper blade is locked in closed position and can be opened by sending a signal to electro motor. Standard thermoelectric release point is 72 °C, optional 95 °C. Actuator is additionally equipped with connection plug for easy connection with power supply and communication modules.

### EX

ATEX rated fire dampers are equipped with Schischek ExMax-5.10-BF actuators, ExPro-TT thermal switches and ExBox-BF plenum boxes. Optional casing can be produced in AISI 316 stainless steel.

## Ordering key

(1) Damper type (2) Dimension (3) Mechanism type (4) Mounted accessories

**FD25 - 400x300 - M230-S - IH**

(1) **FD25** 100x200 till 800x600  
**FD40** 800x600 till 1500x800  
**FD25-APP** 100x200 till 800x600  
**FD25-MF1** 100x200 till 800x600  
**FD25-MF2** 100x200 till 800x600  
**FD40-MF2** 800x600 till 1500x800

(2) Damper dimensions  
**B(W) x H [mm]**

(3) **R** - manual drive  
**R-S** - manual drive with limit switches  
**M230-S** - electric actuator AC230 V  
**M230-S-ST** - electric actuator AC230 V with connection plug  
**M24-S** - electric actuator AC/DC 24 V  
**M24-S-ST** - electric actuator AC/DC 24 V with connection plug  
**M24-S-T95** - electric actuator AC/DC 24 V with thermal fuse 95 °C  
**EMS-S** - electromagnetic drive, permanent  
**EX** - electric actuator Schischek ExMax-5.10-BF +ExPro-TT+ExBox-BF

(4) **IH** - inspection hatch

## FD25/FD40 - R (manual mechanism)

- Automatic closure when the temperature in the duct exceeds 72 °C
- Manual rearming
- Manual unlocking possible for periodical test of fire damper
- Optional with end position switches (-R-S)
- FD25 fire dampers are equipped with R25 manual mechanism
- FD40 fire dampers are equipped with R40 manual mechanism

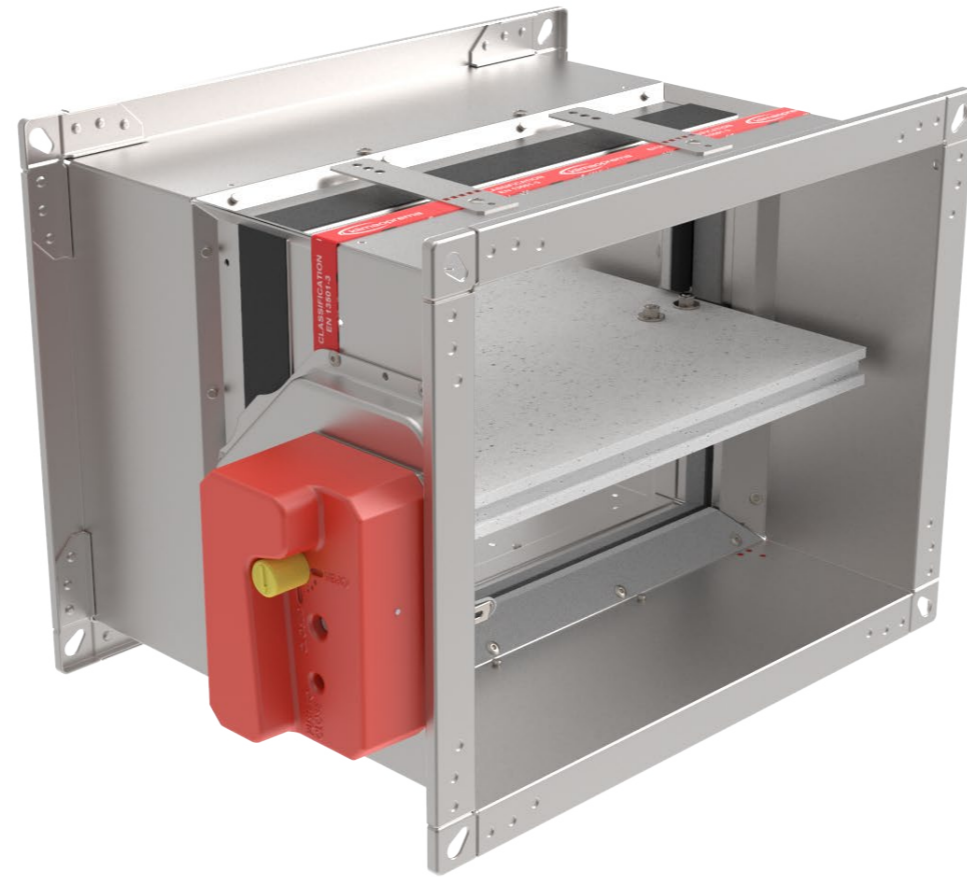

- ▼ [PRODUCT OVERVIEW](#)
- ▼ [DIMENSIONS](#)
- ▼ [INSTALLATIONS](#)
- ▼ [ACTUATORS](#)
- ▼ [ACCESSORIES](#)
- ▼ [REPLACEMENTS](#)
- ▼ [MAINTENANCE AND OPERATION](#)

### DIMENSIONS

Product	A [mm]	C [mm]	D [mm]	E [mm]
FD 25	55	150	105	150
FD 40	55	200	105	200

#### FD25-R25

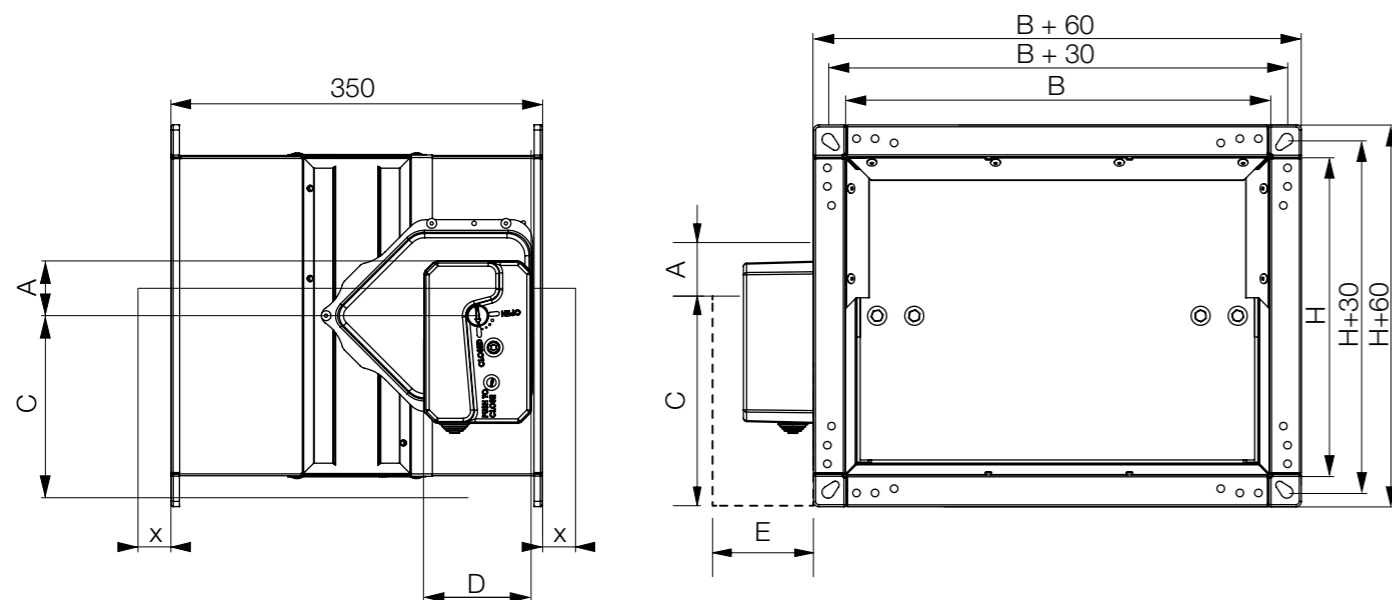

#### FD40-R40

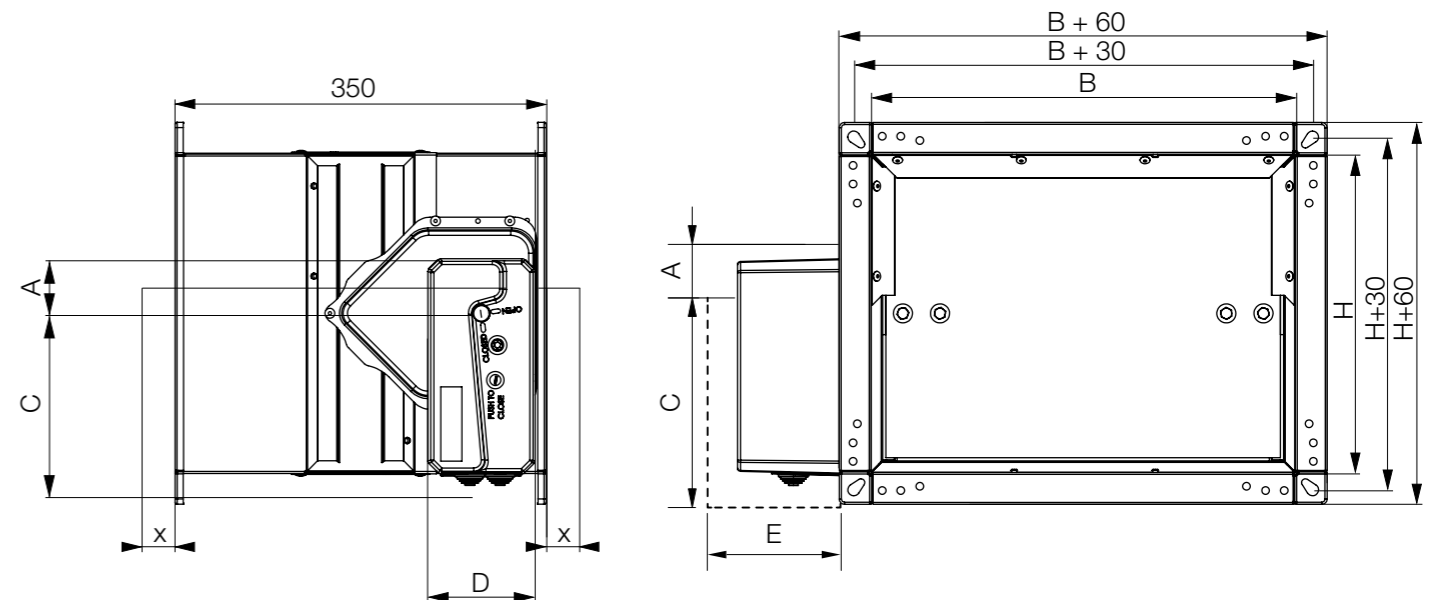

Length of damper blade outside of casing:

$$X=(H/2)-175 \text{ [mm]}$$

### FIRE DAMPER - FD

## FD25/FD40 - EMS (solenoid actuator)

- Spring return actuator with integrated limit switches and thermal fuse release mechanism (72 °C)
- Manual re arming
- Possible closing with solenoid
- Manual closing possible
- EMS - solenoid actuator is constantly under power. Actuating mechanism is tripped when the power is interrupted, or thermal fuse is melted.

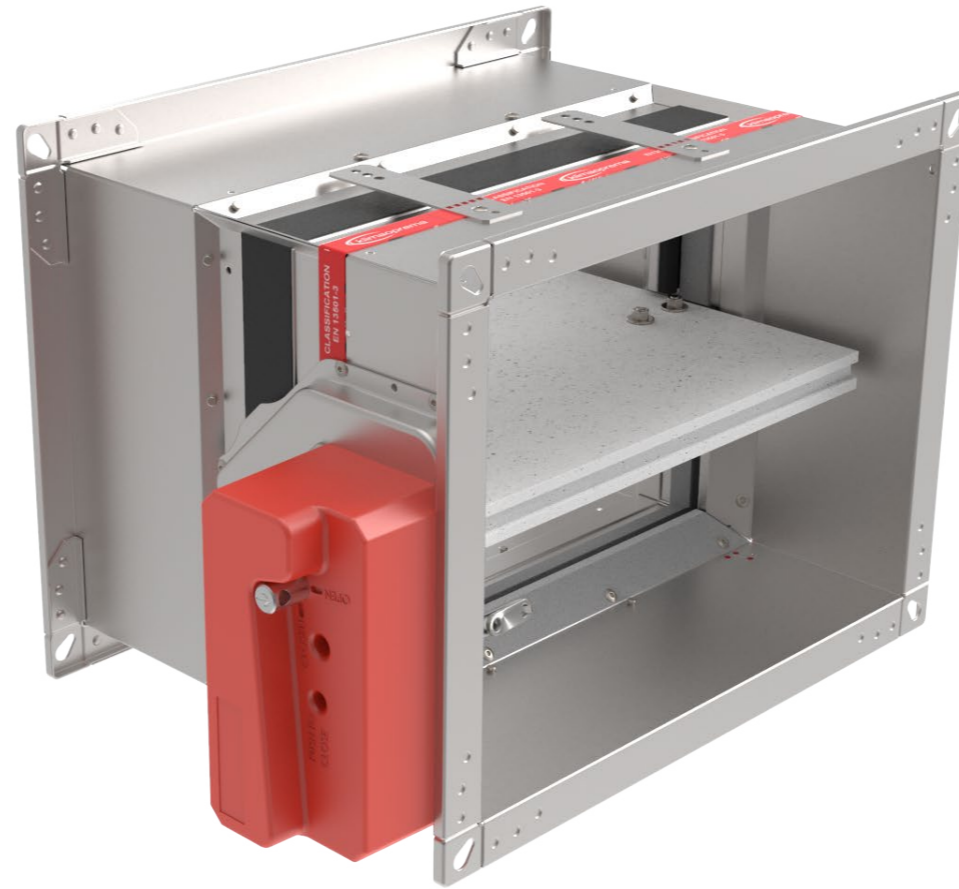

- ▼ [PRODUCT OVERVIEW](#)
- ▼ [DIMENSIONS](#)
- ▼ [INSTALLATIONS](#)
- ▼ [ACTUATORS](#)
- ▼ [ACCESSORIES](#)
- ▼ [REPLACEMENTS](#)
- ▼ [MAINTENANCE AND OPERATION](#)

### DIMENSIONS

Product	A [mm]	C [mm]	D [mm]	E [mm]
FD 25	55	150	105	150
FD 40	55	200	105	200

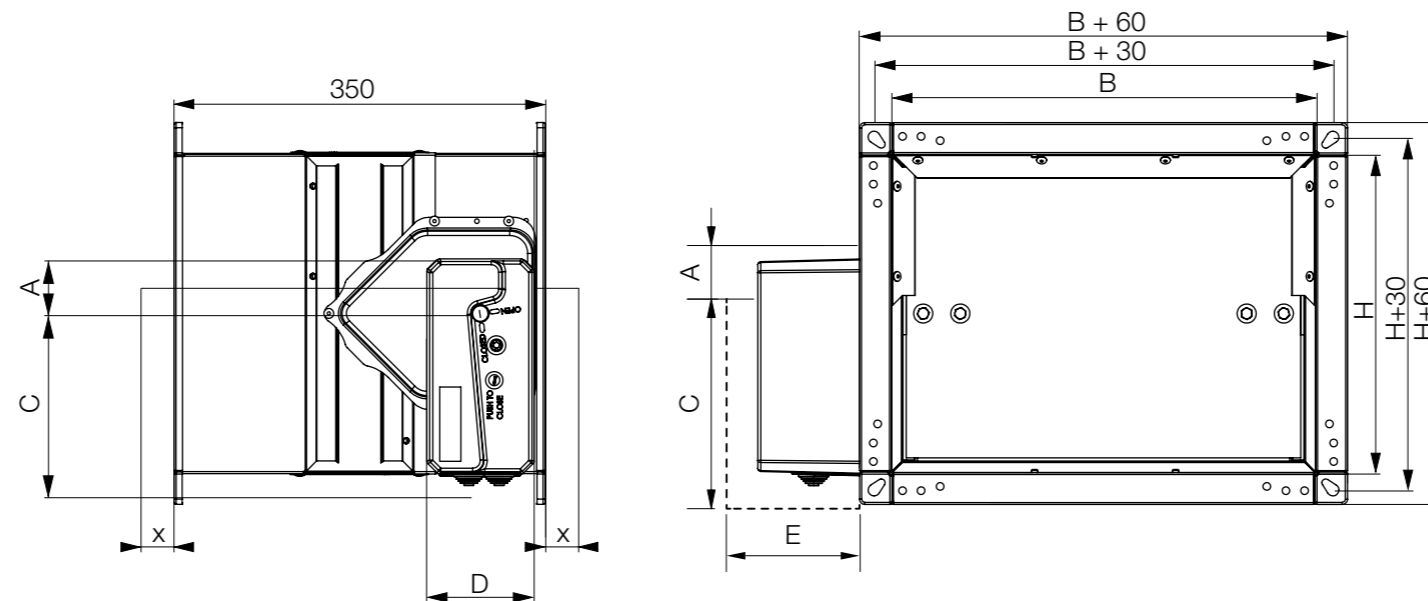

Length of damper blade outside of casing:

$$X=(H/2)-175 \text{ [mm]}$$

### FIRE DAMPER - FD

## FD25/FD40 - M (electric actuator)

- Thermoelectric release device (72 °C) with electric actuator and return spring
- Integrated end switches
- Fully automatic operation
- Optional 95 °C thermoelectric release device for warm air installations

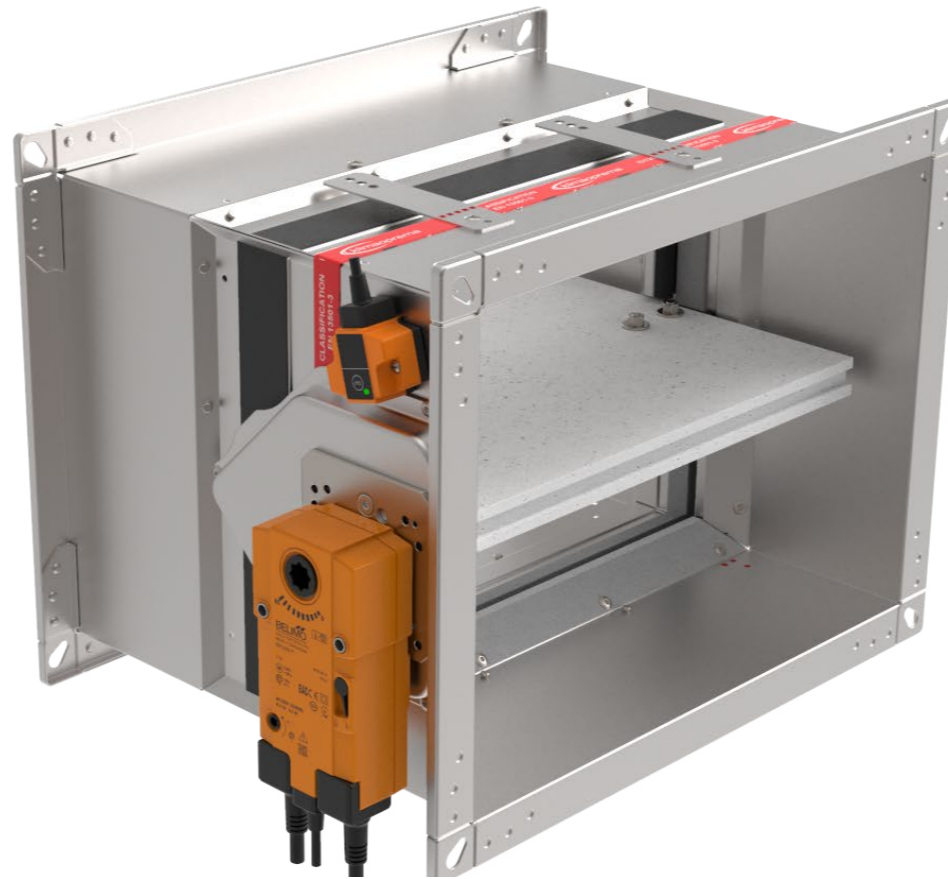

- ▼ [PRODUCT OVERVIEW](#)
- ▼ [DIMENSIONS](#)
- ▼ [INSTALLATIONS](#)
- ▼ [ACTUATORS](#)
- ▼ [ACCESSORIES](#)
- ▼ [REPLACEMENTS](#)
- ▼ [MAINTENANCE AND OPERATION](#)

### DIMENSIONS

Actuator	A [mm]	C [mm]	D [mm]	E [mm]
BFL (M)	25	200	90	120
BFN (M)	25	225	100	120
BF (M)*	50	250	100	120

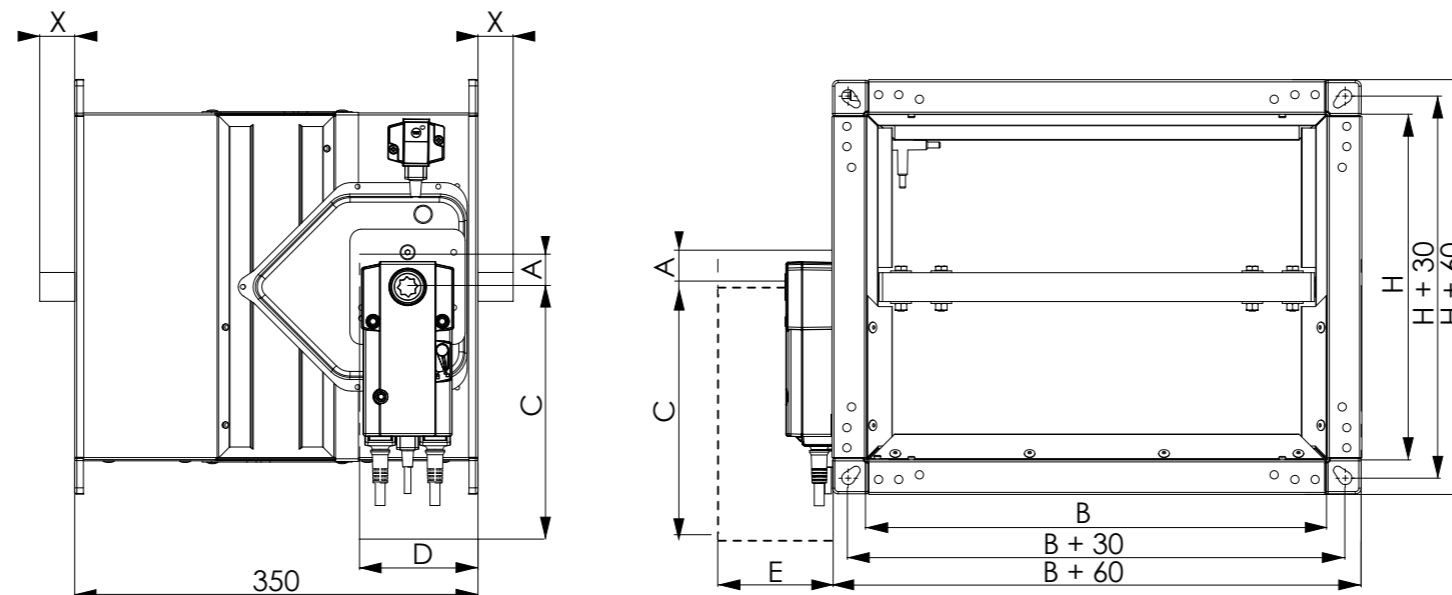

Length of damper blade outside of casing:

$$X = (H/2) - 175 \text{ [mm]}$$

FIRE DAMPER - FD

## FD25/FD40 - EX (electric actuator)

- Thermoelectric release device (72 °C) with electric actuator and return spring
- Integrated end switches
- Fully automatic operation
- The EX version of the damper comes with:
  - 1) Safety temperature trigger Schischek ExPro-TT
  - 2) Electric actuator Schischek ExMax-5.10-BF
  - 3) Terminal box Schischek ExBox-BF

For more information see [page 56](#).

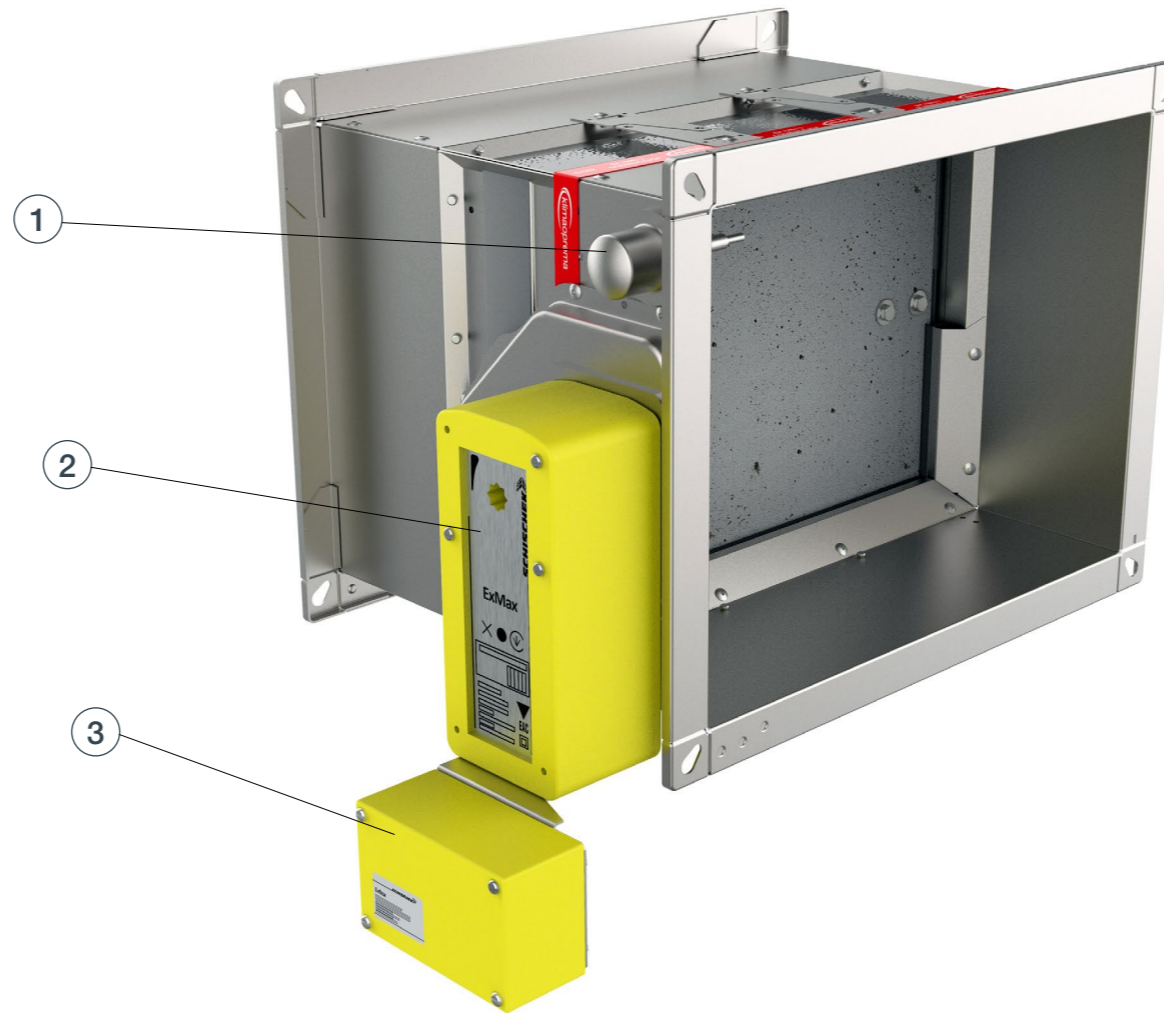

- ▼ [PRODUCT OVERVIEW](#)
- ▼ [DIMENSIONS](#)
- ▼ [INSTALLATIONS](#)
- ▼ [ACTUATORS](#)
- ▼ [ACCESSORIES](#)
- ▼ [REPLACEMENTS](#)
- ▼ [MAINTENANCE AND OPERATION](#)

↑ DIMENSIONS

FIRE DAMPER - FD

### Ex classification of product:

**Ex II 2G Ex h IIC T6 Gb**

**Ex II 2D Ex h IIIC T80°C Db**

For more information about Ex classification, visit website: [ATEX classification](#)  
Type Examination Certificate Number: FIDI 21 ATEX D059. Equipment complies with the essential health and safety requirements relating to the design and construction of equipment intended to use in potentially explosive atmospheres given in annex VIII of the directive ATEX 2014/34/EU.

Please consult latest Declaration of conformity on our website:  
[Actionair FDC](#)

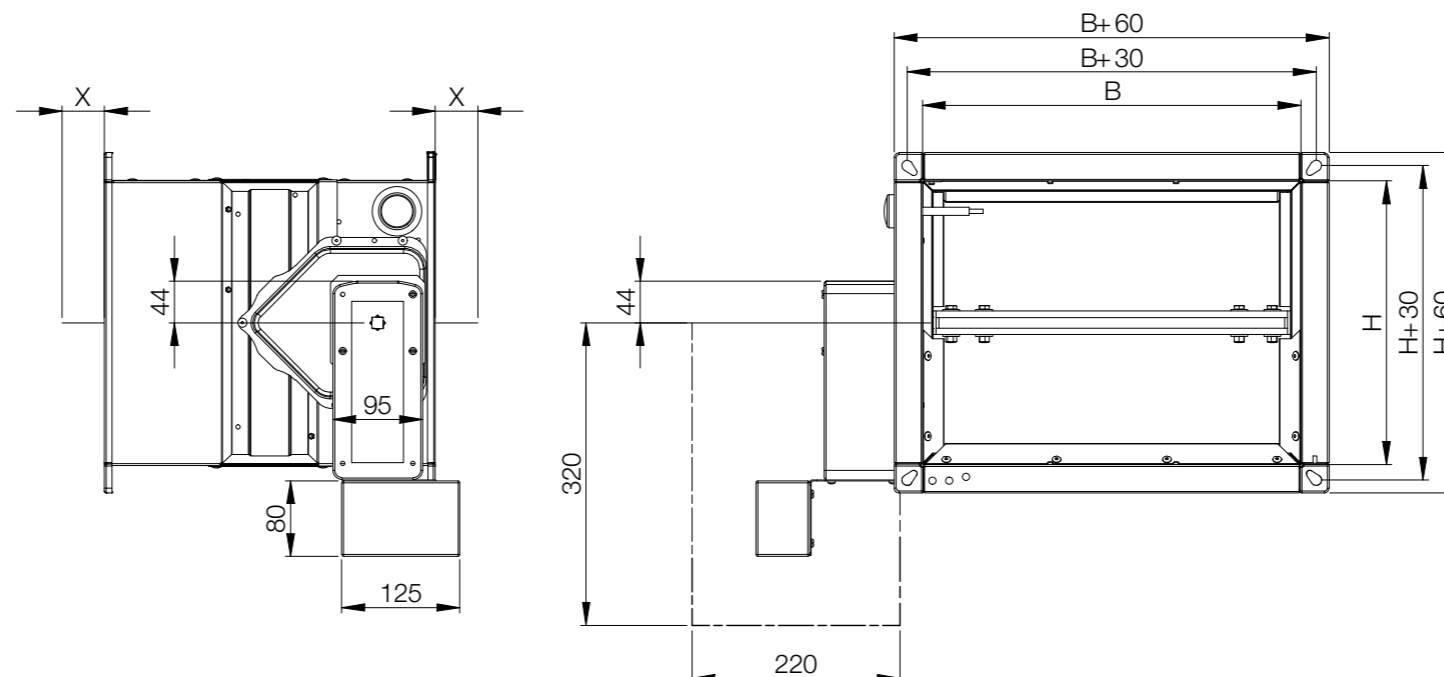

Length of damper blade outside of casing:

$$X=(H/2)-175 \text{ [mm]}$$

## FD25 - APP Applique installation frame

- Applique kit is an installation subframe for quick and easy installation in rigid and flexible walls
- Made out of calcium silicate boards
- Quick wall mounting with screws
- Factory assembled to the fire damper

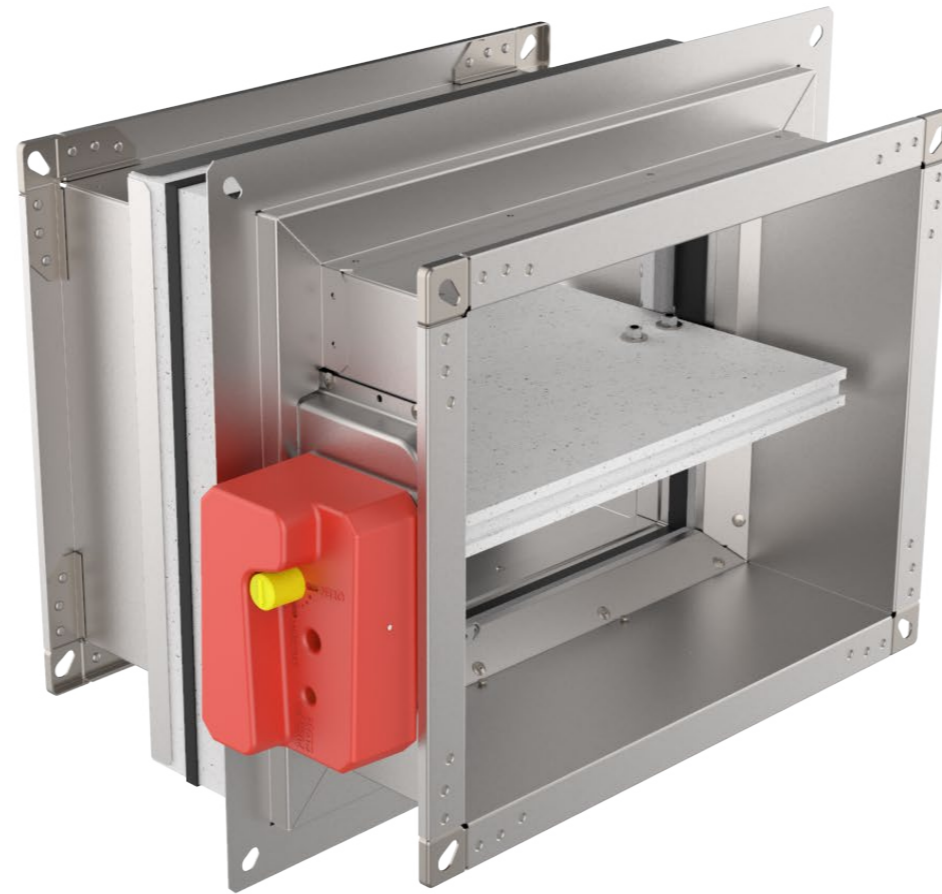

- ▼ [PRODUCT OVERVIEW](#)
- ▼ [DIMENSIONS](#)
- ▼ [INSTALLATIONS](#)
- ▼ [ACTUATORS](#)
- ▼ [ACCESSORIES](#)
- ▼ [REPLACEMENTS](#)
- ▼ [MAINTENANCE AND OPERATION](#)

↑ DIMENSIONS

FIRE DAMPER - FD

FD25-APP-R

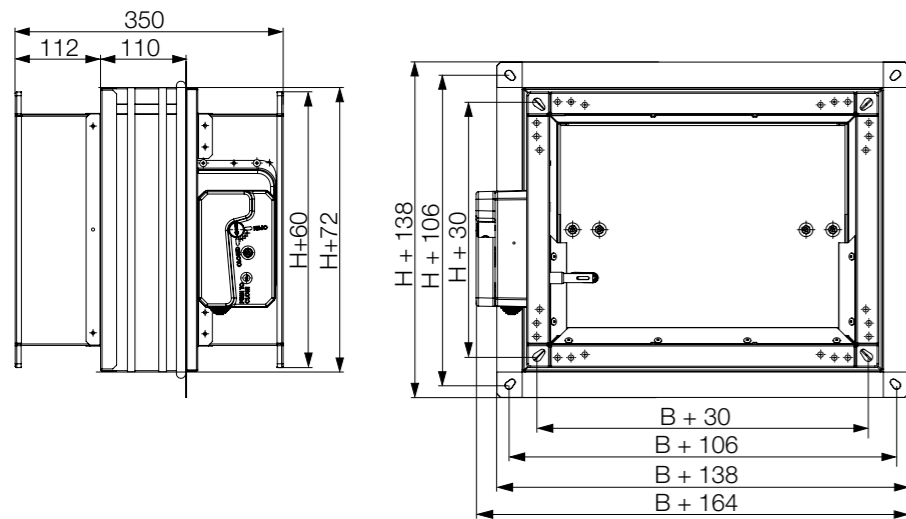

FD25-APP-EMS

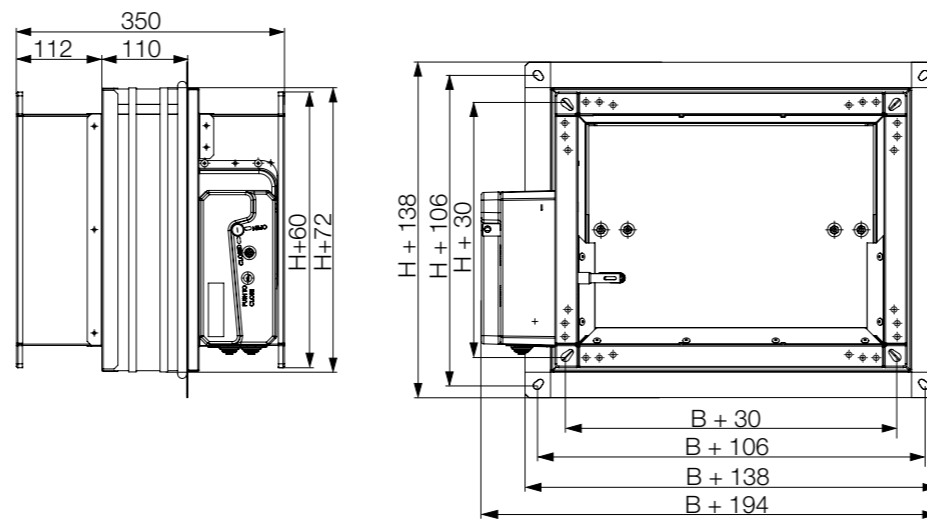

FD25-APP-M

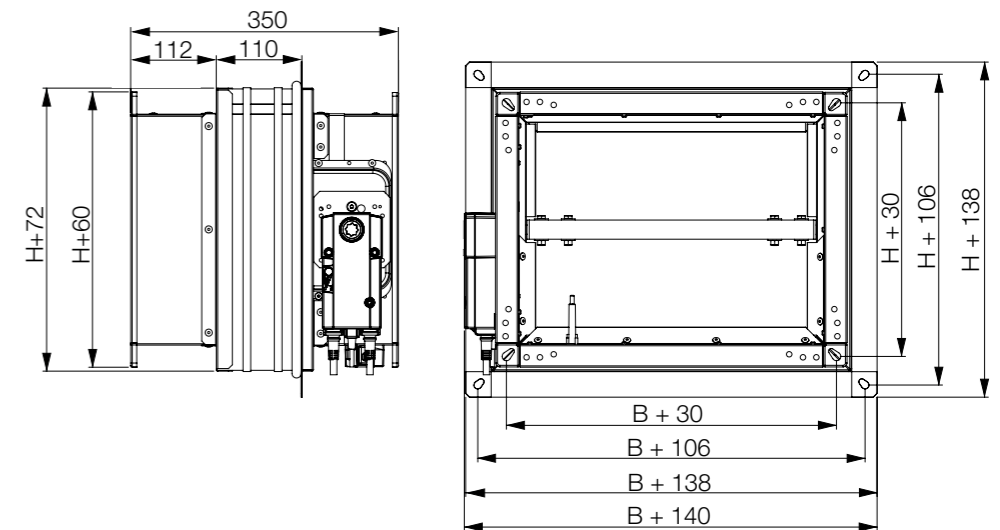

## FD25 MF1 installation frame

- MF1 is an installation frame for quick and easy installation in rigid and flexible walls
- Made out of calcium silicate boards
- Quick wall mounting with screws
- Factory assembled to the fire damper



- ▼ [PRODUCT OVERVIEW](#)
- ▼ [DIMENSIONS](#)
- ▼ [INSTALLATIONS](#)
- ▼ [ACTUATORS](#)
- ▼ [ACCESSORIES](#)
- ▼ [REPLACEMENTS](#)
- ▼ [MAINTENANCE AND OPERATION](#)

↑ DIMENSIONS

FIRE DAMPER - FD

FD25-MF1-R

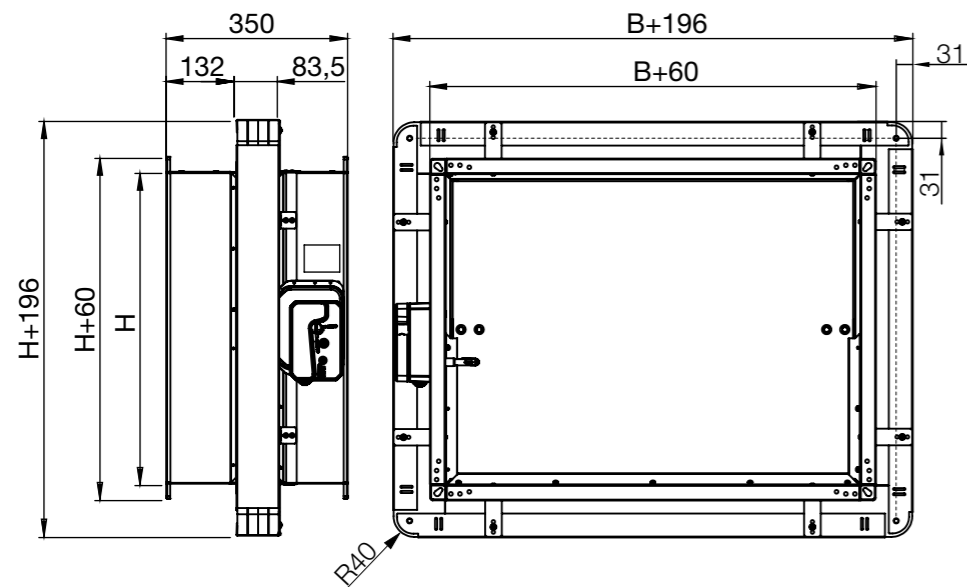

FD25-MF1-EMS

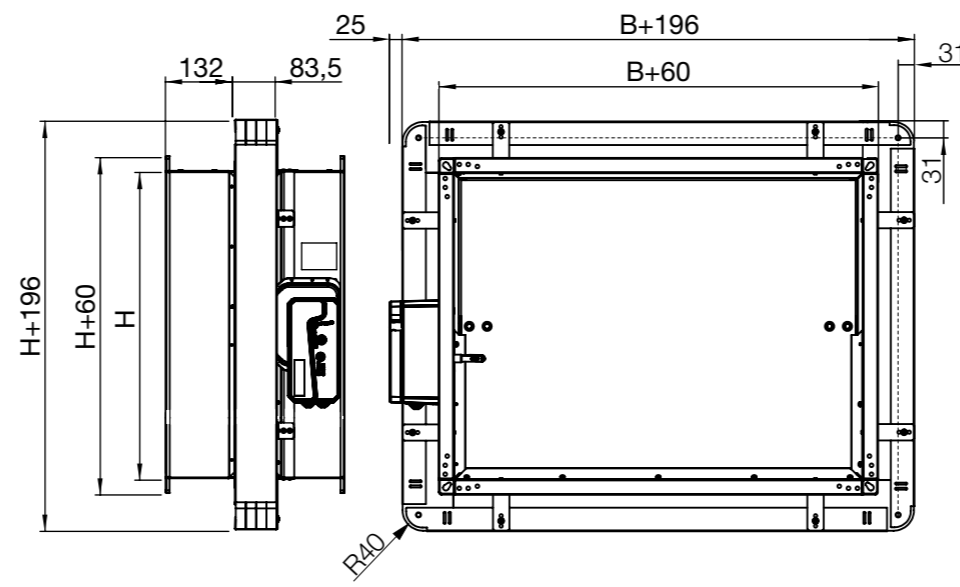

FD25-MF1-M

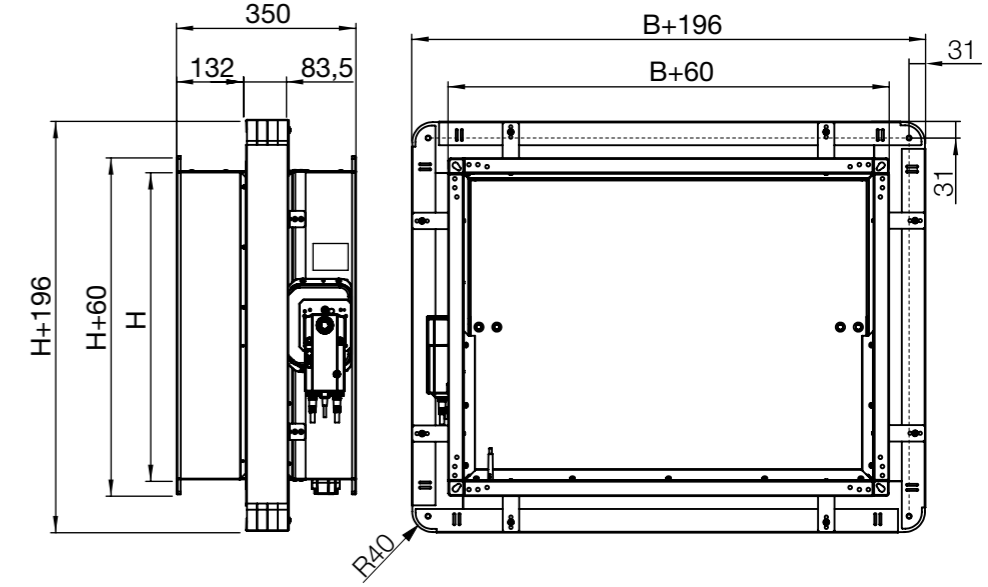

## FD25/FD40 MF2 installation frame

- MF2 is an installation frame for quick and easy installation in rigid and flexible walls
- Made out of calcium silicate boards
- Quick wall mounting with screws
- Factory assembled to the fire damper
- FD25-MF2 possible only for shaft wall installations!

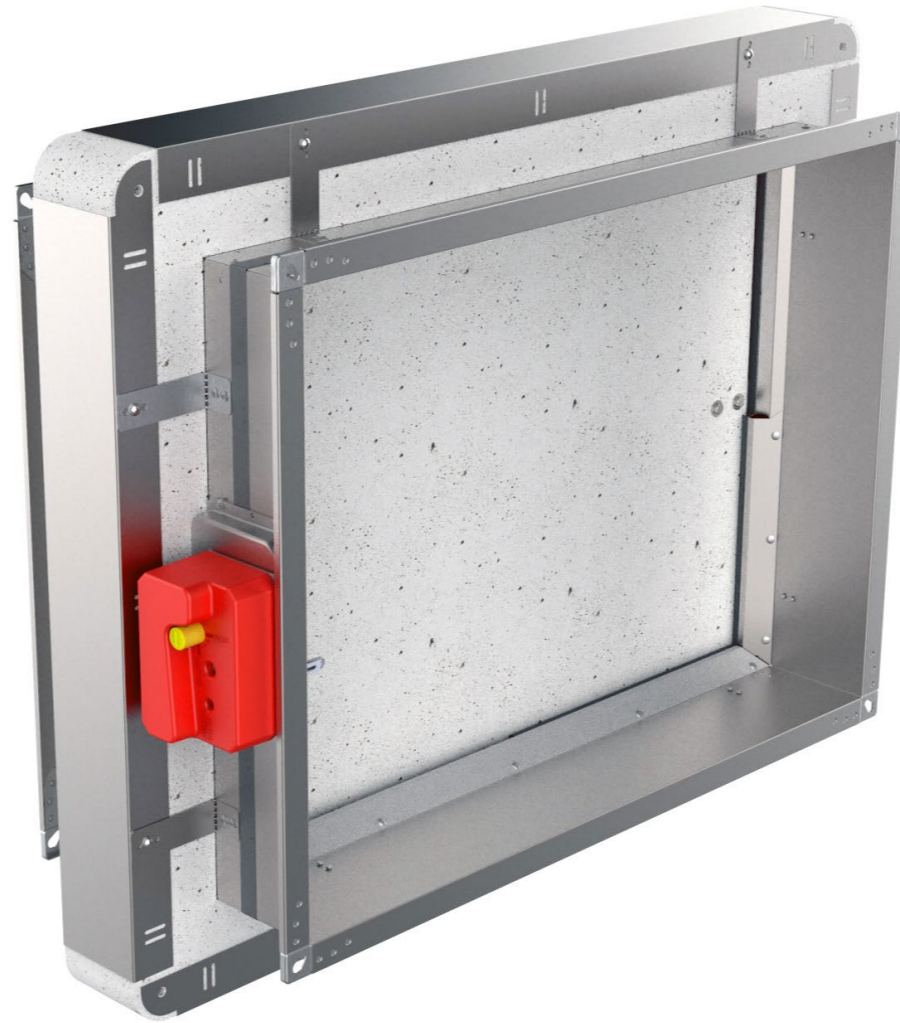

- ▼ [PRODUCT OVERVIEW](#)
- ▼ [DIMENSIONS](#)
- ▼ [INSTALLATIONS](#)
- ▼ [ACTUATORS](#)
- ▼ [ACCESSORIES](#)
- ▼ [REPLACEMENTS](#)
- ▼ [MAINTENANCE AND OPERATION](#)

↑ DIMENSIONS

FIRE DAMPER - FD

FD25-MF2-R

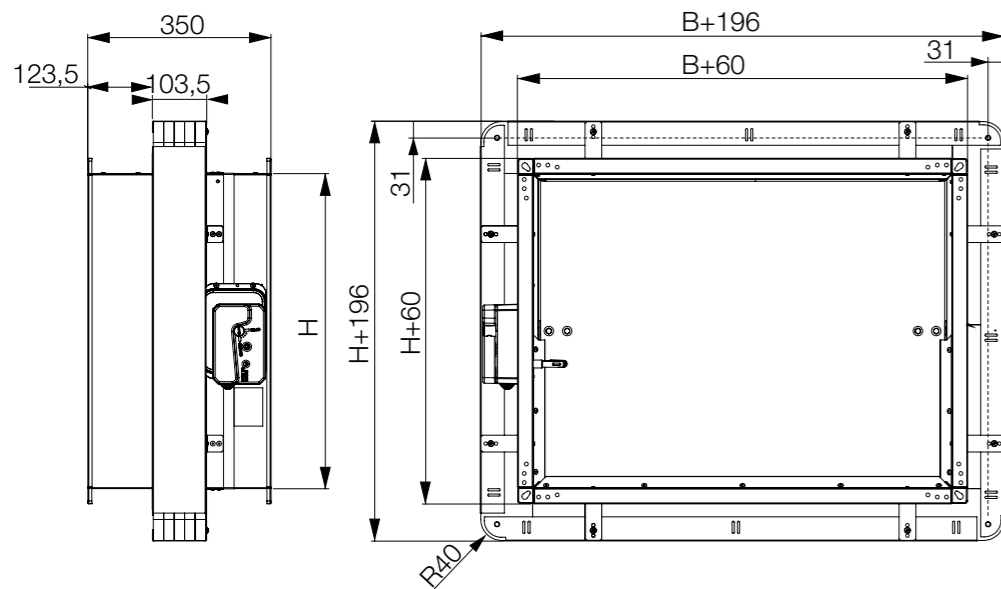

FD25-MF2-EMS

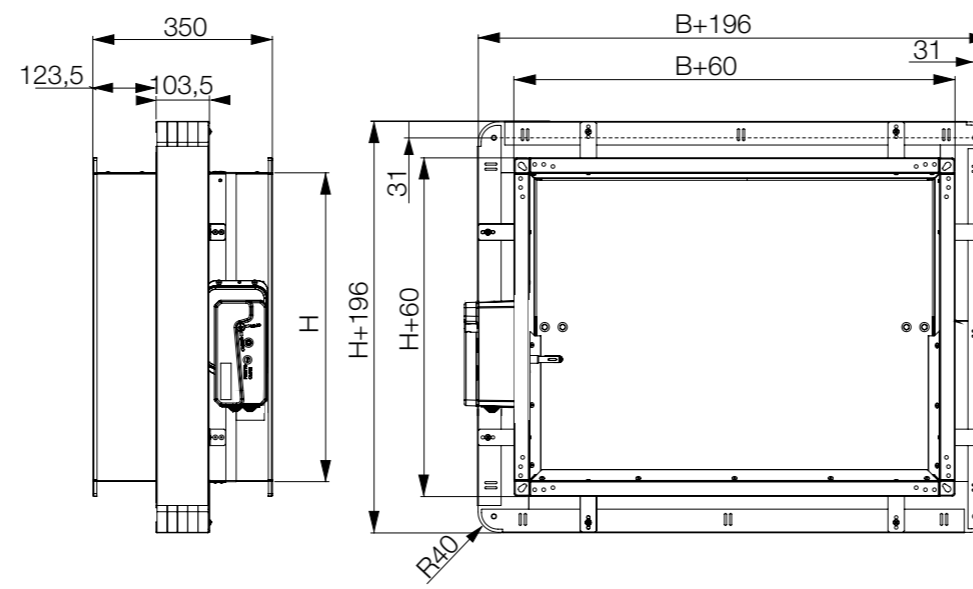

FD40-MF2-R / FD40-MF2-EMS

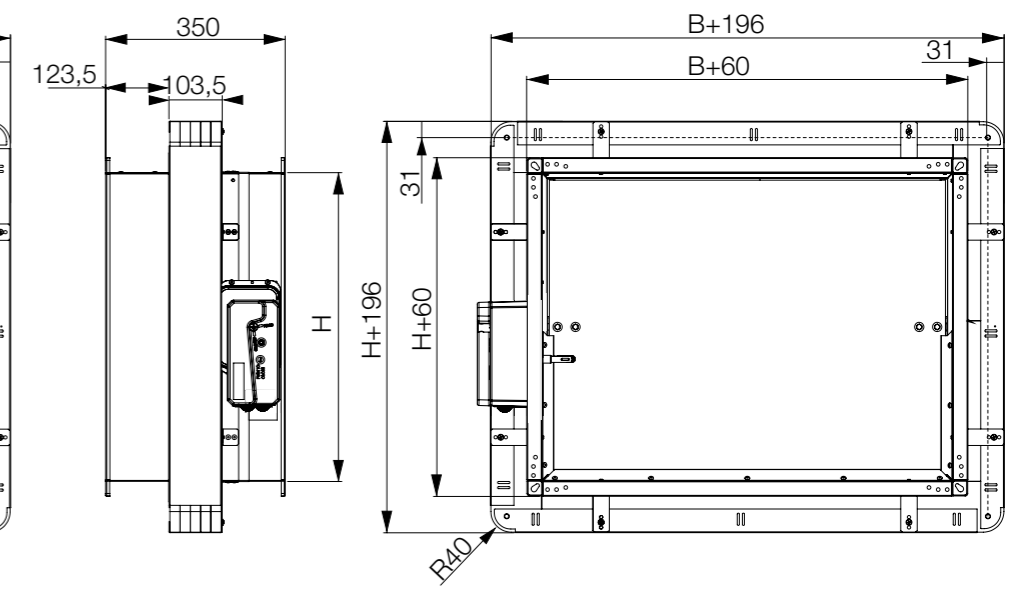

## FD25-MF2-M

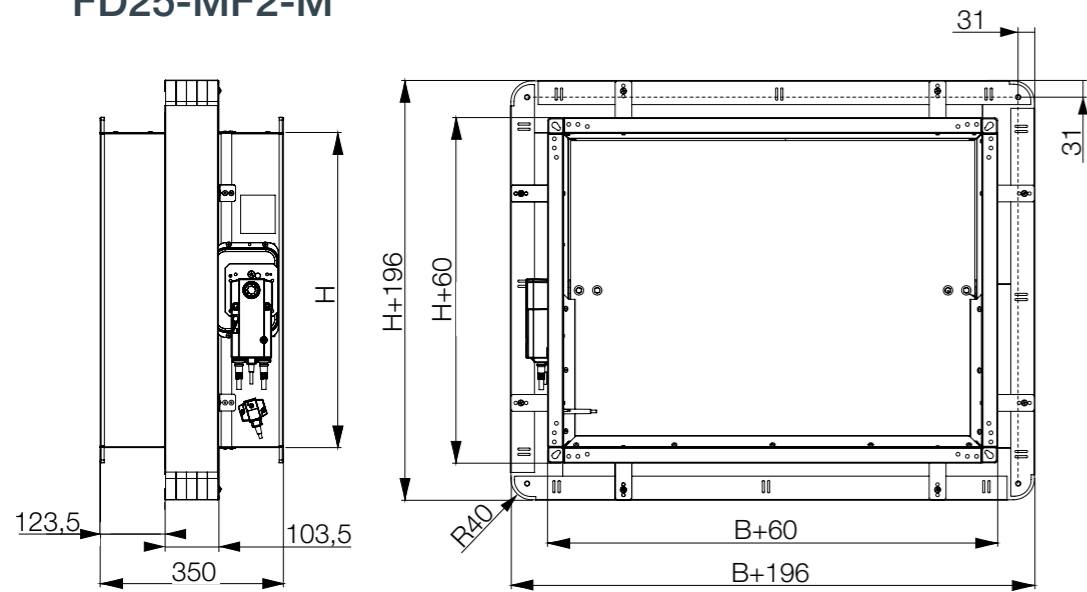

## FD40-MF2-M

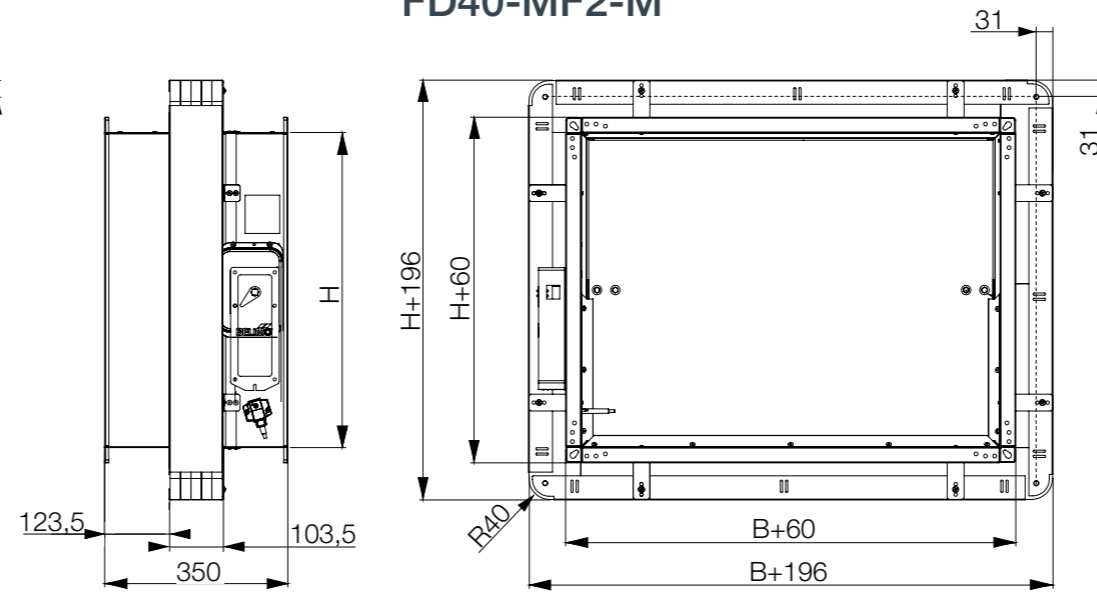

- ▼ [PRODUCT OVERVIEW](#)
- ▼ [DIMENSIONS](#)
- ▼ [INSTALLATIONS](#)
- ▼ [ACTUATORS](#)
- ▼ [ACCESSORIES](#)
- ▼ [REPLACEMENTS](#)
- ▼ [MAINTENANCE AND OPERATION](#)

## Weights tables

FD-R Weight [kg]

H\B	100	150	200	250	300	350	400	450	500	550	600	650	700	750	800	850	900	950	1000	1050	1100	1150	1200	1250	1300	1350	1400	1450	1500
200	5,0	5,6	6,1	6,7	7,3	7,9	8,6	9,2	9,8	10,5	11,1	11,7	12,3	13,0	13,6	17,0	17,7	18,4	19,2	19,9	20,6	21,3	22,1	22,8	23,5	24,3	25,0	25,7	26,4
250	5,7	6,2	6,7	7,4	8,1	8,8	9,5	10,1	10,8	11,5	12,2	12,9	13,6	14,3	15,0	19,0	19,8	20,7	21,5	22,3	23,1	24,0	24,8	25,6	26,5	27,3	28,1	28,9	29,8
300	6,3	6,8	7,3	8,1	8,8	9,6	10,3	11,1	11,8	12,6	13,3	14,1	14,8	15,6	16,3	21,0	22,0	22,9	23,8	24,7	25,7	26,6	28,3	29,2	30,1	31,1	32,0	32,9	33,9
350	6,9	7,4	7,9	8,8	9,6	10,4	11,2	12,0	12,8	13,6	14,5	15,3	16,1	16,9	17,7	23,1	24,1	25,1	26,1	27,2	28,2	29,2	31,0	32,0	33,1	34,1	35,1	36,2	37,2
400	7,6	8,1	8,6	9,5	10,3	11,2	12,1	13,0	13,8	14,7	15,6	16,5	17,3	18,2	19,1	25,8	27,0	28,1	29,2	30,4	31,5	32,6	33,7	34,9	36,0	37,1	38,3	39,4	40,5
450	8,2	8,7	9,2	10,1	11,1	12,0	13,0	13,9	14,8	15,8	16,7	17,7	18,6	19,5	20,5	27,9	29,1	30,3	31,6	32,8	34,0	35,2	36,5	37,7	38,9	40,2	41,4	42,6	43,8
500	8,8	9,3	9,8	10,8	11,8	12,8	13,8	14,8	15,8	16,8	17,8	18,8	19,8	20,8	21,8	29,9	31,2	32,6	33,9	35,2	36,5	37,9	39,2	40,5	41,9	43,2	44,5	45,8	47,2
550	9,4	9,9	10,5	11,5	12,6	13,6	14,7	15,8	16,8	17,9	19,0	20,0	21,1	22,2	23,2	31,9	33,4	34,8	36,2	37,6	39,1	40,5	41,9	43,4	44,8	46,2	47,6	49,1	50,5
600	10,1	10,6	11,1	12,2	13,3	14,5	15,6	16,7	17,8	19,0	20,1	21,2	22,3	23,5	24,6	34,0	35,5	37,0	38,5	40,1	41,6	43,1	44,7	46,2	47,7	49,2	50,8	52,3	53,8
650				16,5	18,1	19,7	21,3	23,0	24,6	26,2	27,8	29,5	31,1	32,7	34,4	36,0	37,6	39,2	40,9	42,5	44,1	45,8	47,4	49,0	50,6	52,3	53,9	55,5	57,1
700					19,0	20,7	22,5	24,2	25,9	27,6	29,4	31,1	32,8	34,6	36,3	38,0	39,7	41,5	43,2	44,9	46,7	48,4	50,1	51,8	53,6	55,3	57,0	58,7	60,5
750						21,8	23,6	25,4	27,2	29,1	30,9	32,7	34,6	36,4	38,2	40,0	41,9	43,7	45,5	47,4	49,2	51,0	52,8	54,7	56,5	58,3	60,1	62,0	63,8
800							24,7	26,6	28,6	30,5	32,4	34,4	36,3	38,2	40,1	42,1	44,0	45,9	47,9	49,8	51,7	53,6	55,6	57,5	59,4	61,3	63,3	65,2	67,1

R25

R40



DIMENSIONS

FD Weight [kg]

H\B	100	150	200	250	300	350	400	450	500	550	600	650	700	750	800	850	900	950	1000	1050	1100	1150	1200	1250	1300	1350	1400	1450	1500
200	4,5	5,1	5,6	6,2	6,8	7,4	8,1	8,7	9,3	10,0	10,6	11,2	11,8	12,5	13,1	15,3	16,0	16,7	17,5	18,2	18,9	19,6	20,4	21,1	21,8	22,6	23,3	24,0	24,7
250	5,2	5,7	6,2	6,9	7,6	8,3	9,0	9,6	10,3	11,0	11,7	12,4	13,1	13,8	14,5	17,3	18,1	19,0	19,8	20,6	21,4	22,3	23,1	23,9	24,8	25,6	26,4	27,2	28,1
300	5,8	6,3	6,8	7,6	8,3	9,1	9,8	10,6	11,3	12,1	12,8	13,6	14,3	15,1	15,8	19,3	20,3	21,2	22,1	23,0	24,0	24,9	26,6	27,5	28,4	29,4	30,3	31,2	32,2
350	6,4	6,9	7,4	8,3	9,1	9,9	10,7	11,5	12,3	13,1	14,0	14,8	15,6	16,4	17,2	21,4	22,4	23,4	24,4	25,5	26,5	27,5	29,3	30,3	31,4	32,4	33,4	34,5	35,5
400	7,1	7,6	8,1	9,0	9,8	10,7	11,6	12,5	13,3	14,2	15,1	16,0	16,8	17,7	18,6	24,1	25,3	26,4	27,5	28,7	29,8	30,9	32,0	33,2	34,3	35,4	36,6	37,7	38,8
450	7,7	8,2	8,7	9,6	10,6	11,5	12,5	13,4	14,3	15,3	16,2	17,2	18,1	19,0	20,0	26,2	27,4	28,6	29,9	31,1	32,3	33,5	34,8	36,0	37,2	38,5	39,7	40,9	42,1
500	8,3	8,8	9,3	10,3	11,3	12,3	13,3	14,3	15,3	16,3	17,3	18,3	19,3	20,3	21,3	28,2	29,5	30,9	32,2	33,5	34,8	36,2	37,5	38,8	40,2	41,5	42,8	44,1	45,5
550	8,9	9,4	10,0	11,0	12,1	13,1	14,2	15,3	16,3	17,4	18,5	19,5	20,6	21,7	22,7	30,2	31,7	33,1	34,5	35,9	37,4	38,8	40,2	41,7	43,1	44,5	45,9	47,4	48,8
600	9,6	10,1	10,6	11,7	12,8	14,0	15,1	16,2	17,3	18,5	19,6	20,7	21,8	23,0	24,1	32,3	33,8	35,3	36,8	38,4	39,9	41,4	43,0	44,5	46,0	47,5	49,1	50,6	52,1
650				14,8	16,4	18,0	19,6	21,3	22,9	24,5	26,1	27,8	29,4	31,0	32,7	34,3	35,9	37,5	39,2	40,8	42,4	44,1	45,7	47,3	48,9	50,6	52,2	53,8	55,4
700					17,3	19,0	20,8	22,5	24,2	25,9	27,7	29,4	31,1	32,9	34,6	36,3	38,0	39,8	41,5	43,2	45,0	46,7	48,4	50,1	51,9	53,6	55,3	57,0	58,8
750						20,1	21,9	23,7	25,5	27,4	29,2	31,0	32,9	34,7	36,5	38,3	40,2	42,0	43,8	45,7	47,5	49,3	51,1	53,0	54,8	56,6	58,4	60,3	62,1
800							23,0	24,9	26,9	28,8	30,7	32,7	34,6	36,5	38,4	40,4	42,3	44,2	46,2	48,1	50,0	51,9	53,9	55,8	57,7	59,6	61,6	63,5	65,4

EMS-S +2,2 kg

EX +4,6 kg

		FD-M Weight [kg]																											
H/B	100	150	200	250	300	350	400	450	500	550	600	650	700	750	800	850	900	950	1000	1050	1100	1150	1200	1250	1300	1350	1400	1450	1500
200	5,6	6,2	6,9	7,5	8,1	8,7	9,4	10,0	10,6	11,3	11,9	12,5	13,1	13,8	14,4	17,8	18,5	19,2	20,0	20,7	21,4	22,1	22,9	23,6	24,3	25,1	25,8	26,5	27,2
250	6,1	6,8	7,5	8,2	8,9	9,6	10,3	10,9	11,6	12,3	13,0	13,7	14,4	15,1	15,8	19,8	20,6	21,5	22,3	23,1	23,9	24,8	25,6	26,4	27,3	28,1	28,9	29,7	30,6
300	6,6	7,4	8,1	8,9	9,6	10,4	11,1	11,9	12,6	13,4	14,1	14,9	15,6	16,4	17,1	21,8	22,8	23,7	24,6	25,5	26,5	27,4	28,3	29,3	30,2	31,1	32,0	33,0	33,9
350	7,1	7,9	8,7	9,6	10,4	11,2	12,0	12,8	13,6	14,4	15,3	16,1	16,9	17,7	18,5	23,9	24,9	25,9	26,9	28,0	29,0	30,0	31,1	32,1	33,1	34,1	35,2	36,2	37,2
400	7,6	8,5	9,4	10,3	11,1	12,0	12,9	13,8	14,6	15,5	16,4	17,3	18,1	19,0	19,9	25,9	27,0	28,1	29,3	30,4	31,5	32,7	33,8	34,9	36,0	37,2	38,3	39,4	40,6
450	8,1	9,1	10,0	10,9	11,9	12,8	13,8	14,7	15,6	16,6	17,5	18,5	19,4	20,3	21,3	27,9	29,1	30,4	31,6	32,8	34,1	35,3	36,5	37,7	39,0	40,2	41,4	42,7	43,9
500	8,6	9,6	10,6	11,6	12,6	13,6	14,6	15,6	16,6	17,6	18,6	19,6	20,6	21,6	22,6	29,9	31,3	32,6	33,9	35,3	36,6	37,9	39,2	40,6	41,9	43,2	44,6	45,9	47,2
550	9,1	10,2	11,3	12,3	13,4	14,4	15,5	16,6	17,6	18,7	19,8	20,8	21,9	23,0	24,0	32,0	33,4	34,8	36,3	37,7	39,1	40,5	42,0	43,4	44,8	46,3	47,7	49,1	50,5
600	9,6	10,8	11,9	13,0	14,1	15,3	16,4	17,5	18,6	19,8	20,9	22,0	23,1	24,3	25,4	34,6	36,1	37,6	39,1	40,7	42,2	43,7	45,3	46,8	48,3	49,8	51,4	52,9	54,4
650			13,7	14,9	16,1	17,3	18,5	19,6	20,8	22,0	30,1	31,8	33,4	35,0	36,6	38,3	39,9	41,5	43,1	44,8	46,4	48,0	49,7	51,3	52,9	54,5	56,2	57,8	
700				15,6	16,9	18,1	19,4	20,6	21,9	23,1	31,8	33,5	35,3	37,0	38,7	40,4	42,2	43,9	45,6	47,4	49,1	50,8	52,5	54,3	56,0	57,7	59,4	61,2	
750					17,7	19,0	20,3	21,6	23,0	24,3	33,4	35,3	37,1	39,0	40,8	42,6	44,4	46,3	48,1	49,9	51,8	53,6	55,4	57,2	59,1	60,9	62,7	64,6	
800						19,9	21,3	22,6	24,0	25,4	35,0	37,0	39,0	40,9	42,9	44,8	46,7	48,7	50,6	52,5	54,4	56,4	58,3	60,2	62,1	64,1	66,0	67,9	

- BFL
- BFN
- BF



- [PRODUCT OVERVIEW](#)
- [DIMENSIONS](#)
- [INSTALLATIONS](#)
- [ACTUATORS](#)
- [ACCESSORIES](#)
- [REPLACEMENTS](#)
- [MAINTENANCE AND OPERATION](#)

## Applique

		APP installation frame weight [kg]													
H/B	100	150	200	250	300	350	400	450	500	550	600	650	700	750	800
200	4,2	4,7	5,2	5,7	6,2	6,7	7,2	7,7	8,2	8,7	9,2	9,7	10,3	10,8	11,3
250	4,7	5,2	5,7	6,2	6,7	7,2	7,7	8,2	8,7	9,2	9,7	10,3	10,8	11,3	11,8
300	5,2	5,7	6,2	6,7	7,2	7,7	8,2	8,7	9,2	9,7	10,3	10,8	11,3	11,8	12,3
350	5,7	6,2	6,7	7,2	7,7	8,2	8,7	9,2	9,7	10,3	10,8	11,3	11,8	12,3	12,8
400	6,2	6,7	7,2	7,7	8,2	8,7	9,2	9,7	10,3	10,8	11,3	11,8	12,3	12,8	13,3
450	6,7	7,2	7,7	8,2	8,7	9,2	9,7	10,3	10,8	11,3	11,8	12,3	12,8	13,3	13,8
500	7,2	7,7	8,2	8,7	9,2	9,7	10,3	10,8	11,3	11,8	12,3	12,8	13,3	13,8	14,3
550	7,7	8,2	8,7	9,2	9,7	10,3	10,8	11,3	11,8	12,3	12,8	13,3	13,8	14,3	14,8
600	8,2	8,7	9,2	9,7	10,3	10,8	11,3	11,8	12,3	12,8	13,3	13,8	14,3	14,8	15,3

## MF1

		MF1 installation frame weight [kg]													
H/B	100	150	200	250	300	350	400	450	500	550	600	650	700	750	800
200	9,1	10,0	10,9	11,8	12,7	13,6	14,5	15,4	16,3	17,2	18,1	19,0	19,9	20,8	21,7
250	10,0	10,9	11,8	12,7	13,6	14,5	15,4	16,3	17,2	18,1	19,0	19,9	20,8	21,7	22,6
300	10,9	11,8	12,7	13,6	14,5	15,4	16,3	17,2	18,1	19,0	19,9	20,8	21,7	22,6	23,5
350	11,8	12,7	13,6	14,5	15,4	16,3	17,2	18,1	19,0	19,9	20,8	21,7	22,6	23,5	24,5
400	12,7	13,6	14,5	15,4	16,3	17,2	18,1	19,0	19,9	20,8	21,7	22,6	23,5	24,5	25,4
450	13,6	14,5	15,4	16,3	17,2	18,1	19,0	19,9	20,8	21,7	22,6	23,5	24,5	25,4	26,3
500	14,5	15,4	16,3	17,2	18,1	19,0	19,9	20,8	21,7	22,6	23,5	24,5	25,4	26,3	27,2
550	15,4	16,3	17,2	18,1	19,0	19,9	20,8	21,7	22,6	23,5	24,5	25,4	26,3	27,2	28,1
600	16,3	17,2	18,1	19,0	19,9	20,8	21,7	22,6	23,5	24,5	25,4	26,3	27,2	28,1	29,0

## MF2

		MF2 installation frame weight [kg]																											
H/B	100	150	200	250	300	350	400	450	500	550	600	650	700	750	800	850	900	950	1000	1050	1100	1150	1200	1250	1300	1350	1400	1450	1500
200	10,7	11,8	12,9	14,0	15,1	16,2	17,3	18,4	19,5	20,6	21,7	22,8	23,9	25,0	26,1	27,2	28,3	29,4	30,5	31,6	32,7	33,8	34,9	36,0	37,1	38,2	39,3	40,4	41,5
250	11,8	12,9	14,0	15,1	16,2	17,3	18,4	19,5	20,6	21,7	22,8	23,9	25,0	26,1	27,2	28,3	29,4	30,5	31,6	32,7	33,8	34,9	36,0	37,1	38,2	39,3	40,4	41,5	42,6
300	12,9	14,0	15,1	16,2	17,3	18,4	19,5	20,6	21,7	22,8	23,9	25,0	26,1	27,2	28,3	29,4	30,5	31,6	32,7	33,8	34,9	36,0	37,1	38,2	39,3	40,4	41,5	42,6	43,7
350	14,0	15,1	16,2	17,3	18,4	19,5	20,6	21,7	22,8	23,9	25,0	26,1	27,2	28,3	29,4	30,5	31,6	32,7	33,8	34,9	36,0	37,1	38,2	39,3	40,4	41,5	42,6	43,7	44,8
400	15,1	16,2	17,3	18,4	19,5	20,6	21,7	22,8	23,9	25,0	26,1	27,2	28,3	29,4	30,5	31,6	32,7	33,8	34,9	36,0	37,1	38,2	39,3	40,4	41,5	42,6	43,7	44,8	45,9
450	16,2	17,3	18,4	19,5	20,6	21,7	22,8	23,9	25,0	26,1	27,2	28,3	29,4	30,5	31,6	32,7	33,8	34,9	36,0	37,1	38,2	39,3	40,4	41,5	42,6	43,7	44,8	45,9	47,0
500	17,3	18,4	19,5	20,6	21,7	22,8	23,9	25,0	26,1	27,2	28,3	29,4	30,5	31,6	32,7	33,8	34,9	36,0	37,1	38,2	39,3	40,4	41,5	42,6	43,7	44,8	45,9	47,0	48,1
550	18,4	19,5	20,6	21,7	22,8	23,9	25,0	26,1	27,2	28,3	29,4	30,5	31,6	32,7	33,8	34,9	36,0	37,1	38,2	39,3	40,4	41,5	42,6	43,7	44,8	45,9	47,0	48,1	49,2
600	19,5	20,6	21,7	22,8	23,9	25,0	26,1	27,2	28,3	29,4	30,5	31,6	32,7	33,8	34,9	36,0	37,1	38,2	39,3	40,4	41,5	42,6	43,7	44,8	45,9	47,0	48,1	49,2	50,4
650			23,9	25,0	26,1	27,2	28,3	29,4	30,5	31,6	32,7	33,8	34,9	36,0	37,1	38,2	39,3	40,4	41,5	42,6	43,7	44,8	45,9	47,0	48,1	49,2	50,4	51,5	
700				26,1	27,2	28,3	29,4	30,5	31,6	32,7	33,8	34,9	36,0	37,1	38,2	39,3	40,4	41,5	42,6	43,7	44,8	45,9	47,0	48,1	49,2	50,4	51,5	52,6	
750					28,3	29,4	30,5	31,6	32,7	33,8	34,9	36,0	37,1	38,2	39,3	40,4	41,5	42,6	43,7	44,8	45,9	47,0	48,1	49,2	50,4				





## Pressure drop tables

Pressure drop values are described with the “Zeta” values for each size. The exact pressure drop in [Pa] is calculated using the following formula:

$$\Delta p \text{ [Pa]} = \zeta * v^2 * 0,6$$

where  $\zeta$  is Zeta value from the tables below, v is airflow velocity in [m/s]



-  [PRODUCT OVERVIEW](#)
-  [DIMENSIONS](#)
-  [INSTALLATIONS](#)
-  [ACTUATORS](#)
-  [ACCESSORIES](#)
-  [REPLACEMENTS](#)
-  [MAINTENANCE AND OPERATION](#)

ZETA VALUES FD25															
H/B	100	150	200	250	300	350	400	450	500	550	600	650	700	750	800
200	1.92	1.67	1.42	1.18	0.99	0.86	0.82	0.77	0.71	0.66	0.65	0.64	0.62	0.59	0.59
250	1.43	1.22	1.02	0.82	0.68	0.61	0.58	0.54	0.52	0.49	0.48	0.43	0.43	0.42	0.42
300	1.15	0.98	0.82	0.65	0.51	0.47	0.45	0.43	0.40	0.40	0.39	0.33	0.33	0.32	0.31
350	0.91	0.78	0.66	0.54	0.44	0.40	0.38	0.37	0.35	0.34	0.33	0.28	0.28	0.27	0.27
400	0.77	0.67	0.58	0.49	0.39	0.35	0.34	0.32	0.30	0.29	0.29	0.25	0.25	0.25	0.24
450	0.61	0.54	0.47	0.40	0.31	0.28	0.28	0.26	0.25	0.25	0.24	0.23	0.22	0.22	0.22
500	0.57	0.50	0.43	0.36	0.28	0.26	0.25	0.24	0.23	0.22	0.22	0.21	0.20	0.20	0.20
550	0.51	0.42	0.33	0.24	0.21	0.18	0.18	0.18	0.17	0.15	0.15	0.15	0.15	0.15	0.14
600	0.49	0.40	0.31	0.22	0.19	0.17	0.17	0.16	0.15	0.15	0.15	0.14	0.13	0.13	0.13

ZETA VALUES FD40																											
H/B	200	250	300	350	400	450	500	550	600	650	700	750	800	850	900	950	1000	1050	1100	1150	1200	1250	1300	1350	1400	1450	1500
200	11.64	9.56	7.48	6.91	6.33	5.71	5.09	5.06	5.04	4.75	4.46	4.45	4.44	4.42	4.39	4.11	3.84	3.83	3.81	3.80	3.79	3.74	3.69	3.69	3.69	3.67	3.66
250	8.58	7.11	5.65	5.20	4.76	4.29	3.82	3.80	3.78	3.56	3.33	3.32	3.31	3.29	3.27	3.07	2.86	2.85	2.84	2.83	2.83	2.80	2.78	2.78	2.78	2.77	2.76
300	5.51	4.67	3.83	3.50	3.18	2.86	2.55	2.54	2.53	2.36	2.20	2.19	2.18	2.17	2.15	2.02	1.89	1.88	1.86	1.86	1.86	1.86	1.86	1.86	1.86	1.86	1.86
350	4.47	3.78	3.10	2.84	2.58	2.32	2.07	2.05	2.03	1.91	1.78	1.77	1.76	1.75	1.75	1.64	1.53	1.52	1.52	1.51	1.51	1.51	1.51	1.51	1.51	1.51	1.51
400	3.42	2.89	2.37	2.17	1.98	1.78	1.59	1.56	1.53	1.45	1.36	1.35	1.34	1.34	1.34	1.26	1.17	1.17	1.17	1.16	1.15	1.15	1.15	1.15	1.15	1.15	1.15
450	2.91	2.47	2.02	1.85	1.67	1.50	1.33	1.31	1.30	1.23	1.15	1.15	1.14	1.14	1.14	1.07	1.00	1.00	1.00	0.99	0.97	0.97	0.97	0.97	0.97	0.97	0.97
500	2.40	2.04	1.68	1.52	1.36	1.21	1.07	1.07	1.07	1.00	0.94	0.94	0.94	0.94	0.94	0.88	0.82	0.82	0.82	0.81	0.80	0.80	0.80	0.80	0.80	0.80	0.80
550	2.13	1.81	1.48	1.35	1.22	1.09	0.97	0.95	0.93	0.88	0.82	0.82	0.82	0.82	0.82	0.76	0.71	0.71	0.71	0.70	0.70	0.70	0.70	0.70	0.70	0.69	0.68
600	1.86	1.57	1.28	1.18	1.08	0.97	0.87	0.84	0.80	0.76	0.71	0.70	0.69	0.69	0.69	0.64	0.59	0.59	0.59	0.59	0.59	0.59	0.59	0.59	0.59	0.58	0.57
650			1.10	1.02	0.93	0.85	0.77	0.74	0.70	0.66	0.62	0.62	0.61	0.61	0.61	0.57	0.53	0.53	0.53	0.53	0.53	0.53	0.52	0.52	0.52	0.51	0.50
700			0.93	0.85	0.78	0.72	0.67	0.63	0.60	0.57	0.53	0.53	0.53	0.53	0.53	0.50	0.47	0.47	0.47	0.47	0.47	0.47	0.46	0.45	0.44	0.44	0.44
750				0.75	0.71	0.65	0.60	0.58	0.56	0.53	0.50	0.49	0.47	0.47	0.47	0.44	0.42	0.42	0.42	0.42	0.42	0.41	0.40	0.40	0.40	0.40	0.40
800					0.63	0.58	0.54	0.53	0.52	0.49	0.46	0.44	0.41	0.41	0.41	0.39	0.36	0.36	0.36	0.36	0.36	0.36	0.35	0.35	0.35	0.35	0.35



### FIRE DAMPER - FD

## INSTALLATION

The FD25/FD40 fire damper is always tested in standardized support frames (both in a concrete wall and in a flexible wall) in accordance with EN 1366-2: 2015 table 3/4/5. The results obtained are valid for all similar support frames which have a thickness and/or density and/or fire resistance similar or greater than the one of the tests.

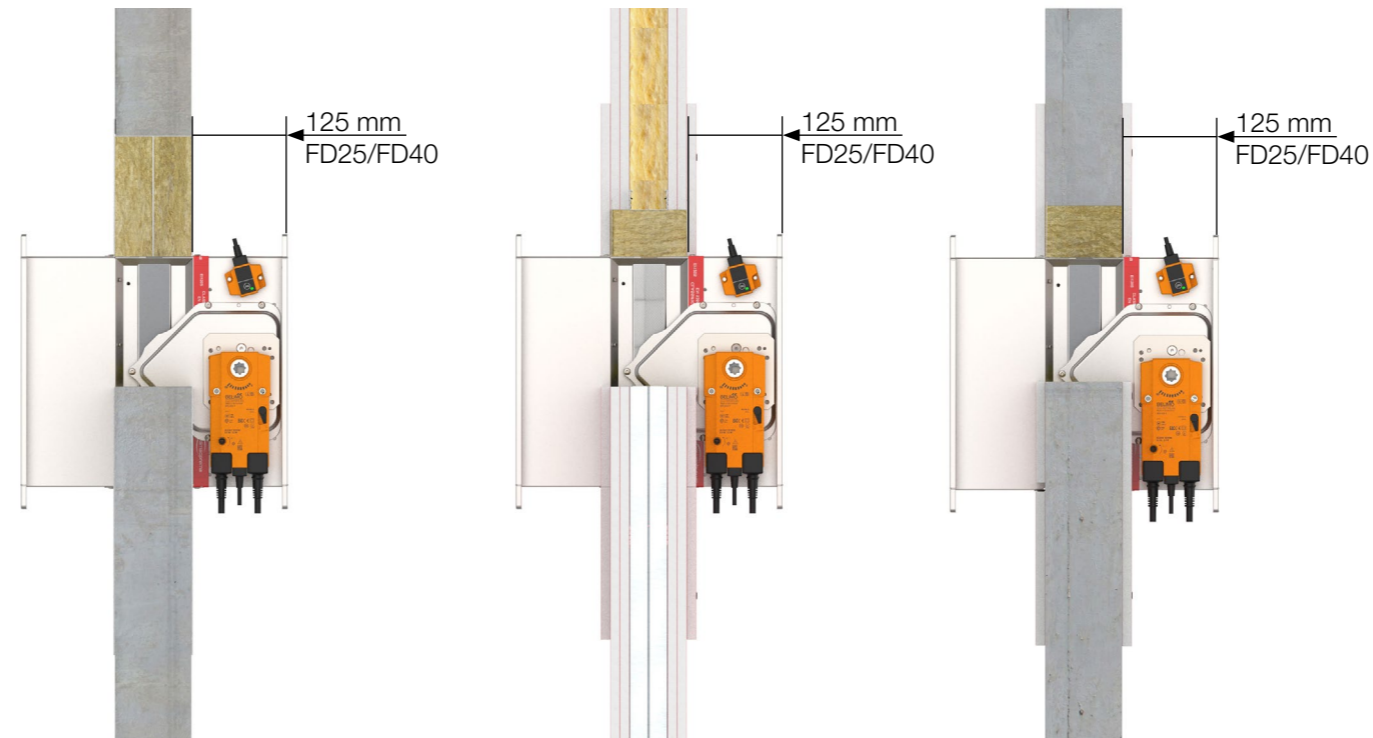

- ▼ [PRODUCT OVERVIEW](#)
- ▼ [DIMENSIONS](#)
- ▼ [INSTALLATIONS](#)
- ▼ [ACTUATORS](#)
- ▼ [ACCESSORIES](#)
- ▼ [REPLACEMENTS](#)
- ▼ [MAINTENANCE AND OPERATION](#)

## FIRE DAMPER - FD

The duct connected to the fire damper must be supported or hung in such a way that the damper does not carry its weight. The damper must not support any part of the surrounding construction or wall which could cause damage and consequent damper failure. It is recommended to connect the damper to a dilatation compensator on either end of the damper.

The damper driving mechanism can be placed on either side of the wall, however it needs to be placed so as to ensure easy access during inspection. Mounting is possible with the blade axis in horizontal or in vertical position

- The installation must comply with the tests that were performed during certification
- Avoid any obstruction of the moving blade by the connected ducts
- The class of air-tightness is maintained in case the installation of the damper is made in accordance with the technical manual
- Operating temperature: 50 °C max
- For indoor use only

The recommended / maximum installation opening is in the table below. The smallest installation opening is where there is enough space to install the seal!

Type of sealing	Recommended opening	Maximum opening
Gypsum	B(H) + 80	B(H) + 120
Mortar	B(H) + 80	B(H) + 150
Mineral wool	B(H) + 80	B(H) + 120
Fire Batt/Weichschott	B(H) + 300	B(H) + 450

All dampers can be installed with the blade axis in a horizontal position or a vertical position in all installation types except installation remote from the wall and battery installation.

The fire damper must be installed into a fire partition structure in such a way that the damper blade in its closed position is located inside this structure (except for installation with Applique/MF1/MF2 installation frame).

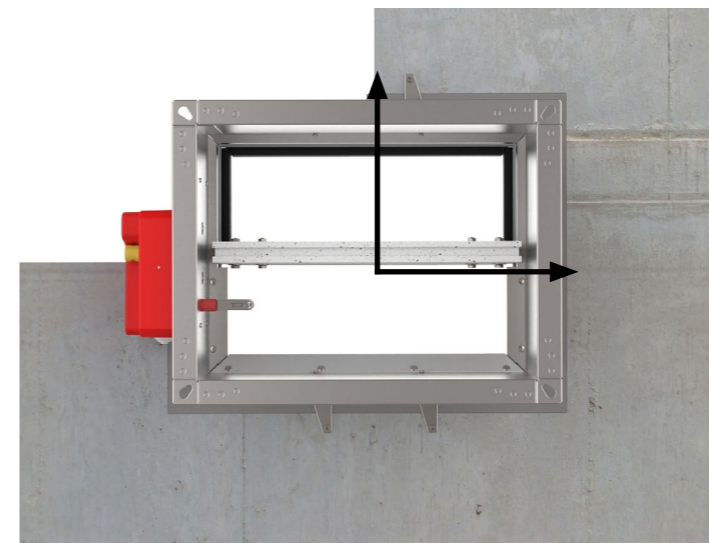

To help you find the suspension plane, a bendable fixing bracket is provided on the damper body (the use of bendable fixing brackets is not required to meet the classification) and the red tape is placed on the casing to mark the location of the wall limit (distance from wall limit to the end of fire damper is 125 mm). This does not apply for Applique/MF1/MF2 kit installations. Check the operation of the fire damper before commencing the installation!

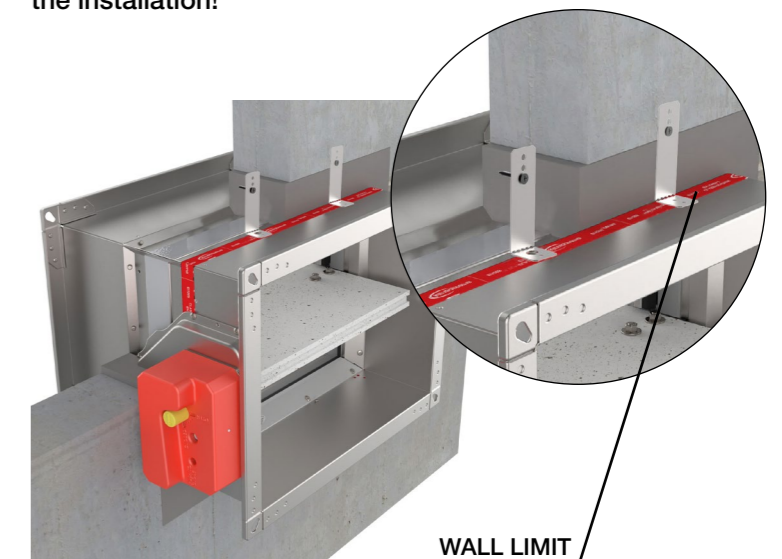

WALL LIMIT

Range	Supporting construction	Type of installation	Wall thickness	Supporting construction details	Classification	Tested underpressure	Details	Construction type	Sealing type		
FD25 / FD40	Rigid wall	Gypsum plaster/Mortar	≥ 100 mm	Aerated concrete (≥ 450 kg/m³) Reinforced concrete (≥ 2200 kg/m³)	EI 120 (ve i↔o)S	500Pa	▼				
		Mineral wool and cover boards								500Pa	▼
		Fire Batt/Weichschott								300Pa	▼
	Flexible wall	Gypsum plaster/Mortar and cover boards	≥ 70 mm	Gypsum blocks (≥ 995 kg/m³)	EI 120 (ve i↔o)S	500Pa	▼				
		Gypsum plaster / Mortar and cover boards								300Pa	▼
		Gypsum plaster / Mortar	≥ 100 mm	A: Plasterboard type F (EN520), mineral wool up to 115 kg/m³ B: Plasterboard type A (EN520), mineral wool up to 60 kg/m³	A: EI 120 (ve i↔o)S B: EI 60 (ve i↔o)S	500Pa	▼				
		Mineral wool and cover boards			A: EI 90 (ve i↔o)S B: EI 60 (ve i↔o)S	500Pa	▼				
		Fire Batt/Weichschott			A: EI 90 (ve i↔o)S B: EI 60 (ve i↔o)S	300Pa	▼				
		Flexible wall	Fire Batt/Weichschott	≥ 75 mm	Plasterboard type F (EN520), mineral wool up to 115 kg/m³	EI 45 (ve i↔o)S	300Pa	▼			
			Fire Batt/ Weichschott		Cross laminated timber (30+40+30 mm)	EI 90 (ve i↔o)S	300Pa	▼			
Eurobond Firemaster Extra	≥ 100 mm		Mineral wool (≥ 23 kg/m³)	FD25:EI 60 (i↔o)S FD40: EI 60 S/ E 90 S (i↔o)S	300Pa	▼					
Eurobond Firemaster Extra, Battery 2x2, 1x2, 2x1		Mineral wool (≥ 23 kg/m³)	FD40: EI 90 (i↔o)S	300Pa	▼						
FD25 / FD40	Rigid wall + Sliding ceiling	Gypsum plaster / Mortar + Mineral wool (70 kg/m³)	≥ 100 mm	Aerated concrete (≥ 450 kg/m³)	EI 120 (ve i↔o)S	300Pa	▼				
	Flexible wall + Sliding ceiling	Gypsum plaster / Mortar and cover boards + Mineral wool (115 kg/m³)	≥ 100 mm	Plasterboard type F (EN520)	EI 120 (ve i↔o)S	300Pa	▼				
	Floor/ceiling	Gypsum plaster/Mortar	≥ 100 mm	Aerated concrete (≥ 450 kg/m³) Reinforced concrete (≥ 2200 kg/m³)	EI 120 (ho i↔o)S	500Pa	▼				
Fire Batt/Weichschott		EI 90 (ho i↔o)S			300Pa	▼					
APP INSTALLATION FRAME FD25 100x200 till 800x600 mm	Rigid wall	APPLIQUE (installation frame)	≥ 100 mm	Aerated concrete (≥ 450 kg/m³) Reinforced concrete (≥ 2200kg/m³)	EI 90 (ve i↔o)S	500Pa	▼				
		APPLIQUE (installation frame)	≥ 70 mm	Gypsum blocks (≥ 995 kg/m³)	EI 90 (ve i↔o)S	500Pa	▼				
	Flexible wall	APPLIQUE (installation frame)	≥ 100 mm	Plasterboard type F (EN520) type A (EN520)	EI 90 (ve i↔o)S EI 60 (ve i↔o)S	500Pa	▼				

## INSTALLATION

Check for more information about certificate installations in the declaration of performance:

- Aerated concrete (≥ 450 kg/m³) or reinforced concrete (≥ 2200 kg/m³) wall, more than 100 mm thick
- Gypsum blocks (≥ 995 kg/m³) wall, more than 70 mm thick
- Plasterboard wall, type F (EN520), Plasterboard wall, type A (EN520), more than 100 mm thick
- Shaft wall, steel frame construction
- Aerated concrete (≥ 450 kg/m³) or reinforced concrete (≥ 2200 kg/m³) ceiling / floor, more than 100 mm thick

## FIRE DAMPER - FD

- Gypsum plaster, mortar sealing or mortar and cover boards. Mortar EN 998-2 Classes M 2.5 to M 20 or equivalent mortars that meet the requirements of the above standards, gypsum mortar or concrete.
- Sealing with mineral wool and cover boards
- Sealing with mineral wool and fireproof coating - FireBatt
- Applique kit installation
- MF1/MF2 kit installation
- Remote from wall installation
- Battery installation

Range	Supporting construction	Type of installation	Wall thickness	Supporting construction details	Classification	Tested underpressure	Details	Construction type	Sealing type			
MF1/ MF2 INSTALLATION FRAME FD25 MF1/MF2 100x200 till 800x600 mm FD40 MF2 800x600 till 1500x800 mm	Rigid wall	MF1 (installation frame)	≥ 100 mm	Aerated concrete (≥ 450 kg/m³) Reinforced concrete (≥ 2200kg/m³)	FD25: EI 60 (ve i↔o)S	500Pa	▼					
		MF2 (installation frame)		EI 90 (ve i↔o)S	FD25: 300Pa FD40: 500Pa							
		MF1 (installation frame)	≥ 70 mm	Gypsum blocks (≥ 995 kg/m³)	FD25: EI 60 (ve i↔o)S	500Pa				▼		
		MF2 (installation frame)		EI 90 (ve i↔o)S								
	Flexible wall	MF1 (installation frame)	≥ 100 mm	Plasterboard A: type A (EN520) B: type F (EN520)	A: FD25:EI 60 (ve i↔o)S B: FD25:EI 60 (ve i↔o)S	500Pa	▼					
		MF2 (installation frame)			A:EI 60 (ve i↔o)S B:EI 90 (ve i↔o)S							
	Floor/ceiling	MF1 (installation frame)	≥ 100 mm	Aerated concrete (≥ 450 kg/m³) Reinforced concrete (≥ 2200 kg/m³)	FD25: EI 120 (ho i↔o)S	300Pa				▼		
		MF2 (installation frame)			FD40: EI 90 (ho i↔o)S							
MF2 INSTALLATION FRAME FD25/FD40	Flexible wall	MF2 (installation frame)	≥ 75 mm	Shaft wall (steel frame)	EI 60 (ve i↔o)S	300Pa	▼					
			≥ 90 mm		EI 90 (ve i↔o)S							
FD25 / FD40	Rigid wall	REMOTE FROM WALL (Isover)	≥ 100 mm	Aerated concrete (≥ 450 kg/m³) Reinforced concrete (≥ 2200 kg/m³)	EI 60 (ve i↔o)S	300Pa				▼		
	Flexible wall											
FD40	Rigid wall	REMOTE FROM WALL (Promat)	≥ 110 mm	Aerated concrete (≥ 450 kg/m³) Reinforced concrete (≥ 2200 kg/m³)	EI 120 (ve i↔o)S	300Pa	▼					
FD40	Rigid wall	Battery 2x2, 2x1, 1x2	≥ 100 mm	Aerated concrete (≥ 450 kg/m³) Reinforced concrete (≥ 2200 kg/m³)	EI 120 (ve i↔o)S	500Pa						
	Floor/ceiling									Battery 2x2, 2x1, 1x2	EI 120 (ho i↔o)S	

## INSTALLATION

Check for more information about certificate installations in the declaration of performance:

- Aerated concrete (≥ 450 kg/m³) or reinforced concrete (≥ 2200 kg/m³) wall, more than 100 mm thick
- Gypsum blocks (≥ 995 kg/m³) wall, more than 70 mm thick
- Plasterboard wall, type F (EN520), Plasterboard wall, type A (EN520), more than 100 mm thick
- Shaft wall, steel frame construction
- Aerated concrete (≥ 450 kg/m³) or reinforced concrete (≥ 2200 kg/m³) ceiling / floor, more than 100 mm thick

## FIRE DAMPER - FD

- Gypsum plaster, mortar sealing od mortar and cover boards
- Sealing with mineral wool and cover boards
- Sealing with mineral wool and fireproof coating - FireBatt
- Applique kit installation
- MF1/MF2 kit installation
- Remote from wall installation
- Battery installation

## Rigid wall installation (mortar sealing)

The wall is composed of concrete blocks (minimum density of 450 kg/m<sup>3</sup>) or reinforced concrete (minimum density of 2200 kg/m<sup>3</sup>) and with a minimum thickness of 100 mm.  
Installation material:  
mortar (C).



### INSTALLATION

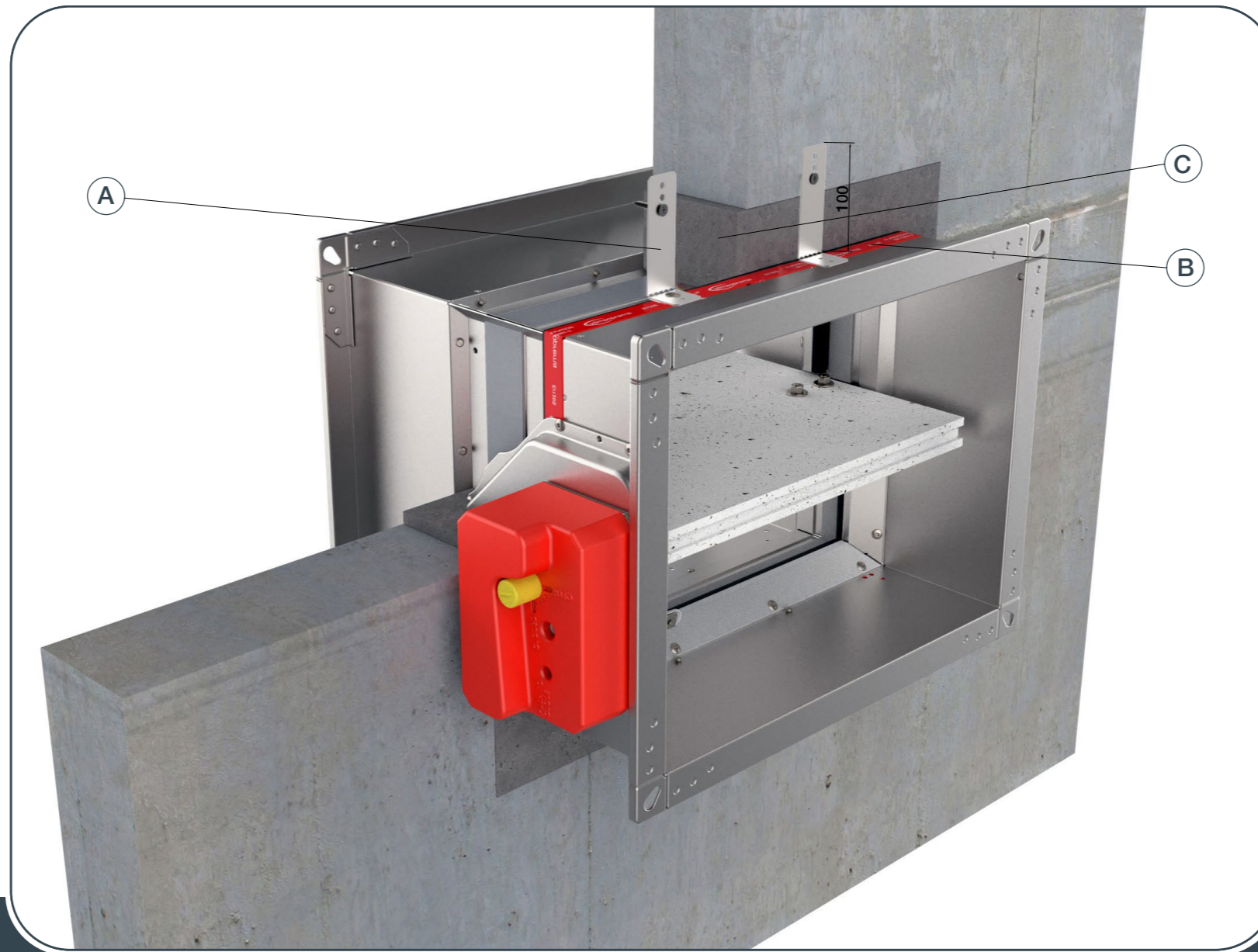

- ▼ [PRODUCT OVERVIEW](#)
- ▼ [DIMENSIONS](#)
- ▼ [INSTALLATIONS](#)
- ▼ [ACTUATORS](#)
- ▼ [ACCESSORIES](#)
- ▼ [REPLACEMENTS](#)
- ▼ [MAINTENANCE AND OPERATION](#)

Possible damper orientations



FIRE DAMPER - FD

**Always ensure the damper is sufficiently supported and a breakaway joint is incorporated between the damper and adjoining ductwork on both sides**

1. Recommended wall opening for the fire damper installation is B (H) + 80 mm or more (up to 50% more). Bend the fixing bracket (A) 90°. Place the damper in the opening up to the wall limit mark (B) on the damper.

**Damper blade must be closed during the installation!**

2. Fix the fire damper to the wall with the screws. Bracket screw hole is 6 mm in diameter.

3. Fill the space between the damper and the wall with mortar (C).

\*Multiple fire dampers can be installed next to each other or ceiling/wall with the minimal distance as shown on [page 52](#).

\* Build the support for installation according to the drawing, [see page 53](#).

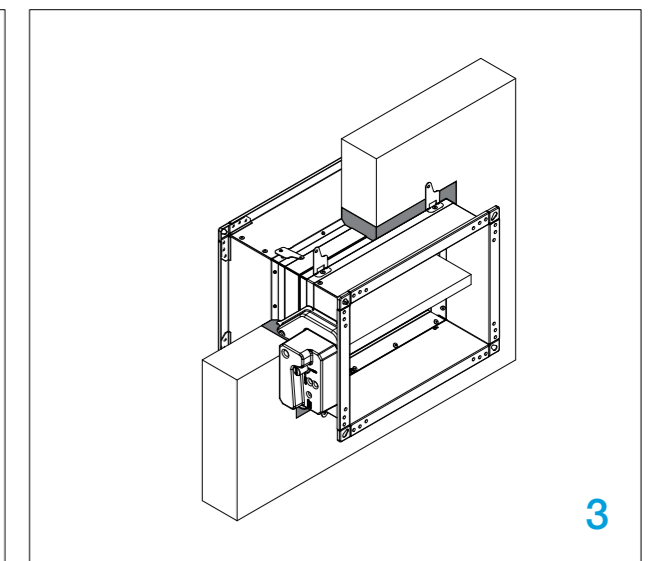
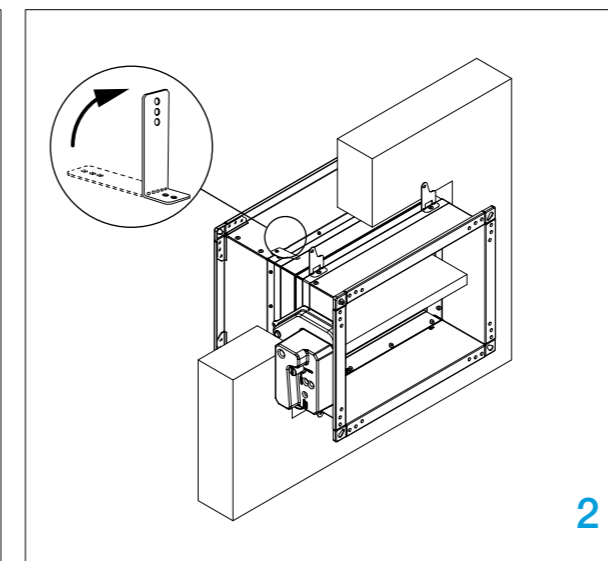
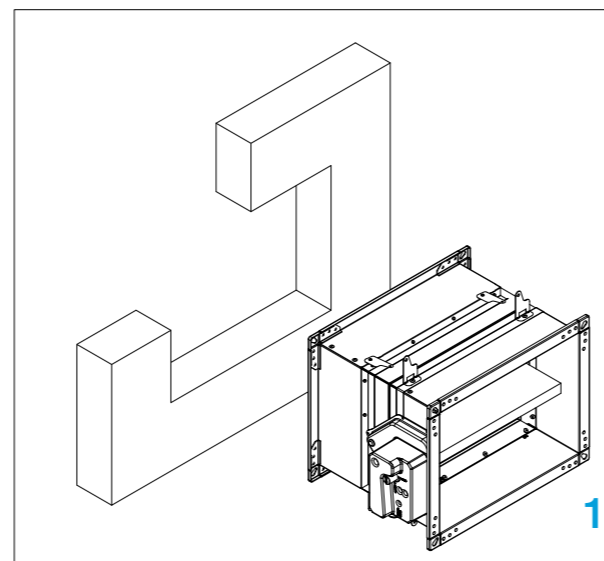

**Test the operation of the damper blade!**

## Rigid wall installation (mineral wool sealing)

The wall is composed of concrete blocks (minimum density of 450 kg/m<sup>3</sup>) or reinforced concrete (minimum density of 2200 kg/m<sup>3</sup>) and with a minimum thickness of 100 mm. Installation material: mineral wool (C) (minimum density of 100 kg/m<sup>3</sup>) covered with plasterboard cover boards (D).

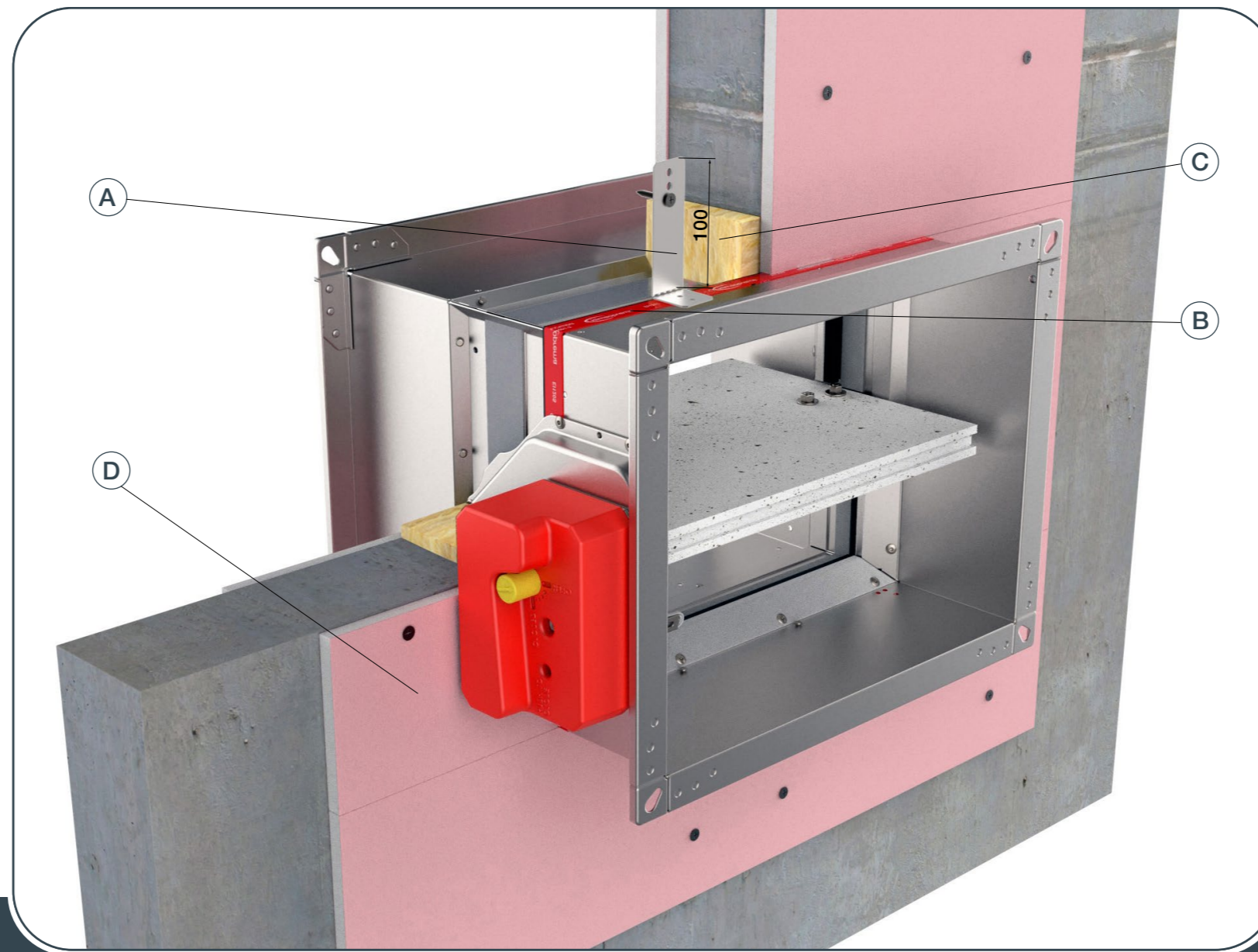

- ▼ PRODUCT OVERVIEW
- ▼ DIMENSIONS
- ▼ INSTALLATIONS
- ▼ ACTUATORS
- ▼ ACCESSORIES
- ▼ REPLACEMENTS
- ▼ MAINTENANCE AND OPERATION

Possible damper orientations



FIRE DAMPER - FD

**Always ensure the damper is sufficiently supported and a breakaway joint is incorporated between the damper and adjoining ductwork on both sides**

1. Recommended wall opening for the fire damper installation is B (H) + 80 mm or more (up to 50% more). Bend the fixing bracket (A) 90° (bracket screw hole is 6 mm in diameter). Place the damper in the opening up to the wall limit mark (B) on the damper.

**Damper blade must be closed during the installation!**

2. Fix the fire damper to the wall with the screws.

3. Fill the space between casing and wall with mineral wool (C).

4. Cover the wool with GKF gypsum boards (D) (12,5 mm thick).

\*Multiple fire dampers can be installed next to each other or ceiling/wall with the minimal distance as shown on [page 52](#).

**Test the operation of the damper blade!**

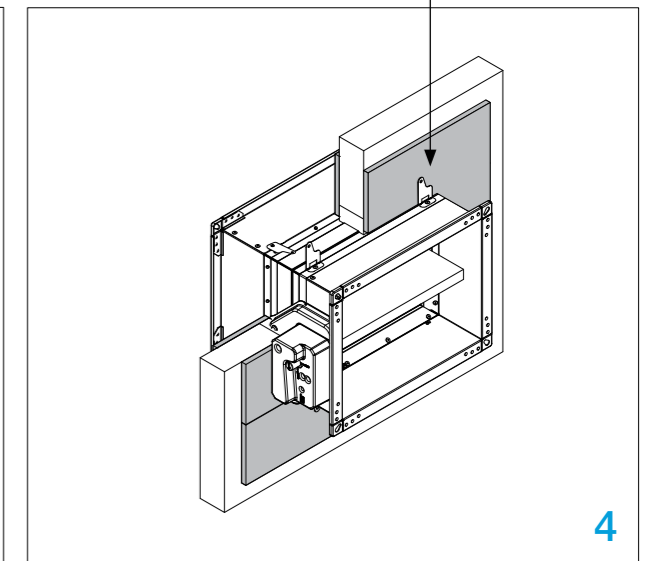
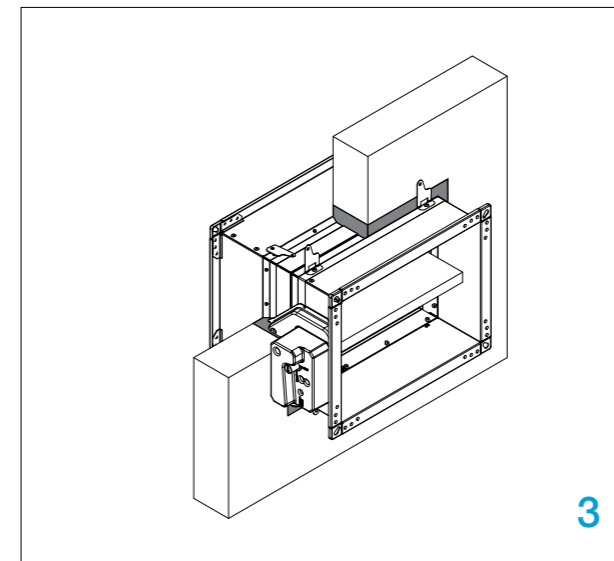
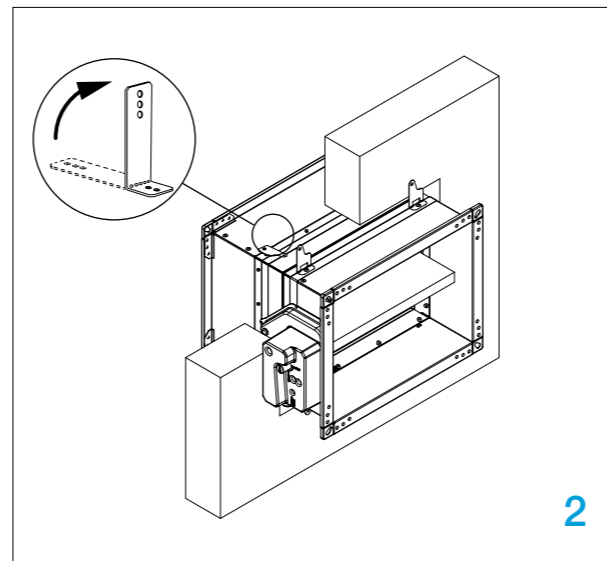
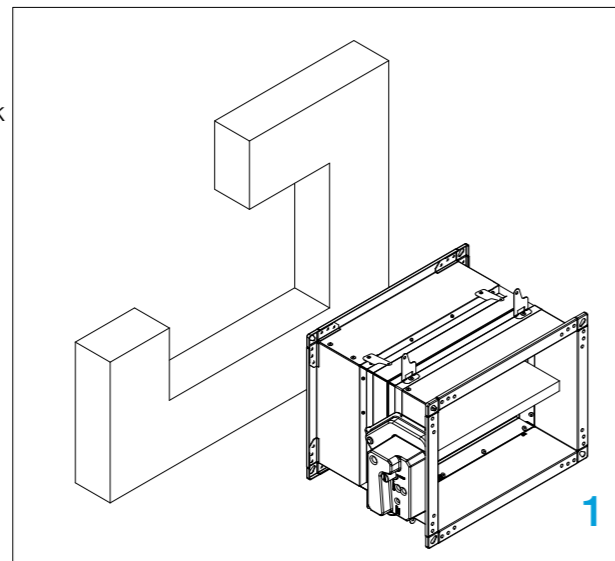

FD-A-CSP-BxH  
For more details see [pg.59](#)

## Rigid wall installation (Fire Batt/ Weichschott)

The wall is composed of concrete blocks (minimum density of 450 kg/m<sup>3</sup>) or reinforced concrete (minimum density of 2200 kg/m<sup>3</sup>) and with a minimum thickness of 100 mm. Installation material: mineral wool (C) (minimum density of 140 kg/m<sup>3</sup>), fire protection coating (D).



### INSTALLATION

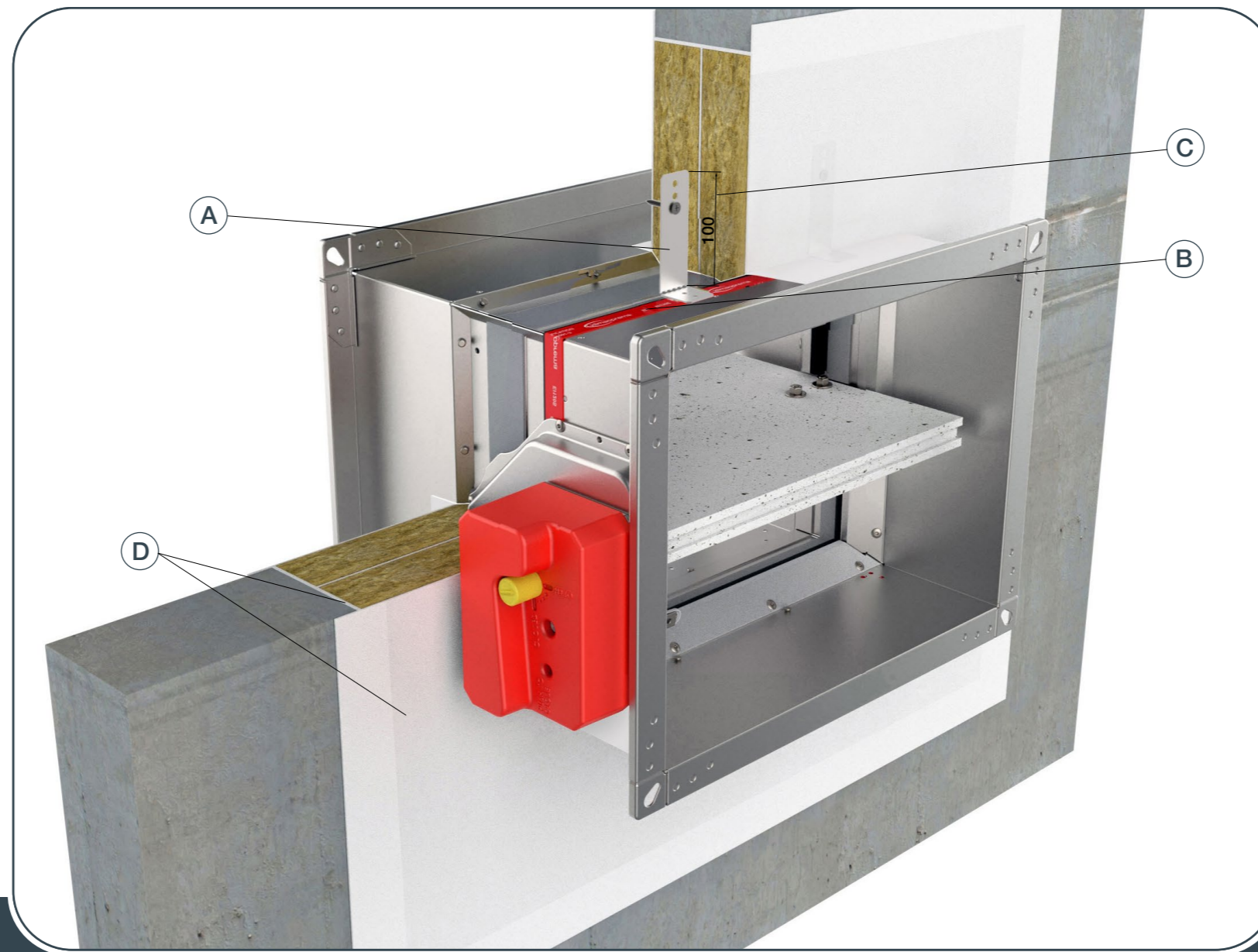

- ▼ PRODUCT OVERVIEW
- ▼ DIMENSIONS
- ▼ INSTALLATIONS
- ▼ ACTUATORS
- ▼ ACCESSORIES
- ▼ REPLACEMENTS
- ▼ MAINTENANCE AND OPERATION

Possible damper orientations



FIRE DAMPER - FD

1. Recommended wall opening for fire damper installation is B(H) + 300 mm, but openings from B(H) + 80...450 mm can also be used.

2. Bend the fixing bracket (A) 90° (bracket screw hole is 6 mm in diameter). Place the damper in the opening up to the wall limit mark (B) on the damper.

**Damper blade must be closed during installation!**

3. Close space between casing and wall with two layers of mineral wool (C) (50 mm thick, coated on one side). Seal the connections of mineral wool with wall and damper with intumescent fire resistant sealant (D). Mineral wool and damper casing must be coated with 2 mm thick fire protection coating. Damper casing should be coated up to profile flanges.

\*Multiple fire dampers can be installed next to each other or ceiling/wall with the minimal distance as shown on [page 52](#).

\*\*Fire Batt/ Weichschott installations adjacent to ceiling or wall require a suspension for the fire damper. For more details, [see page 37](#).

**Test the operation of the damper blade!**

**Always ensure the damper is sufficiently supported and a breakaway joint is incorporated between the damper and adjoining ductwork on both sides**

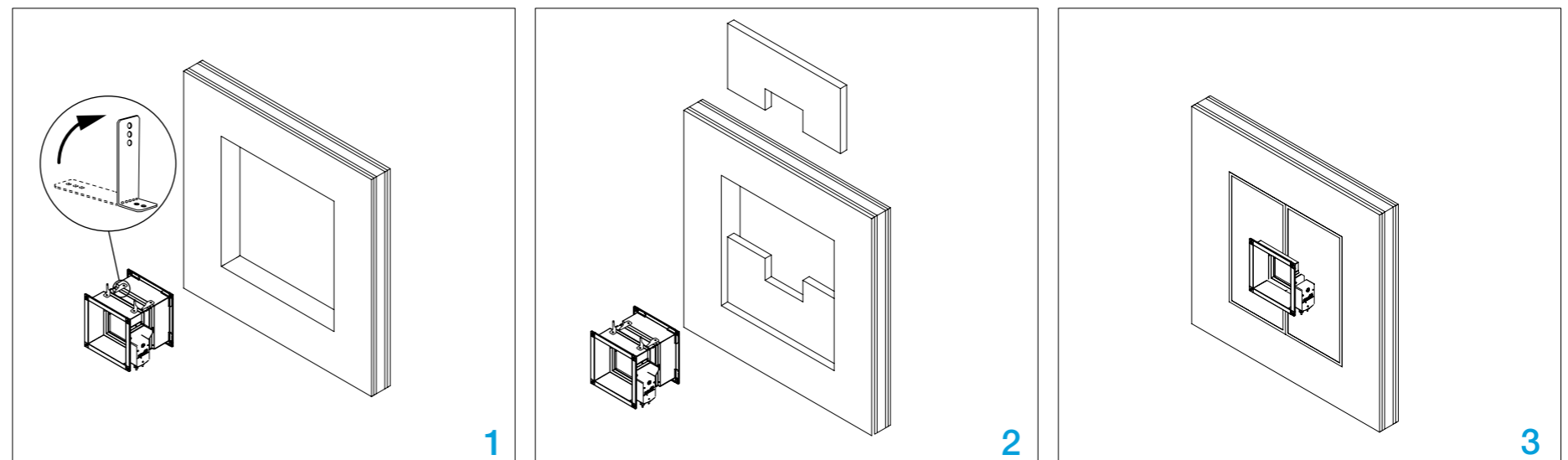

## Gypsum blocks wall installation (mortar sealing)

The wall is composed of gypsum blocks (minimum density of 995 kg/m<sup>3</sup>) and with minimum thickness of 70 mm. Installation material: gypsum plaster or mortar (C), covered with plasterboard cover boards (D).



### INSTALLATION

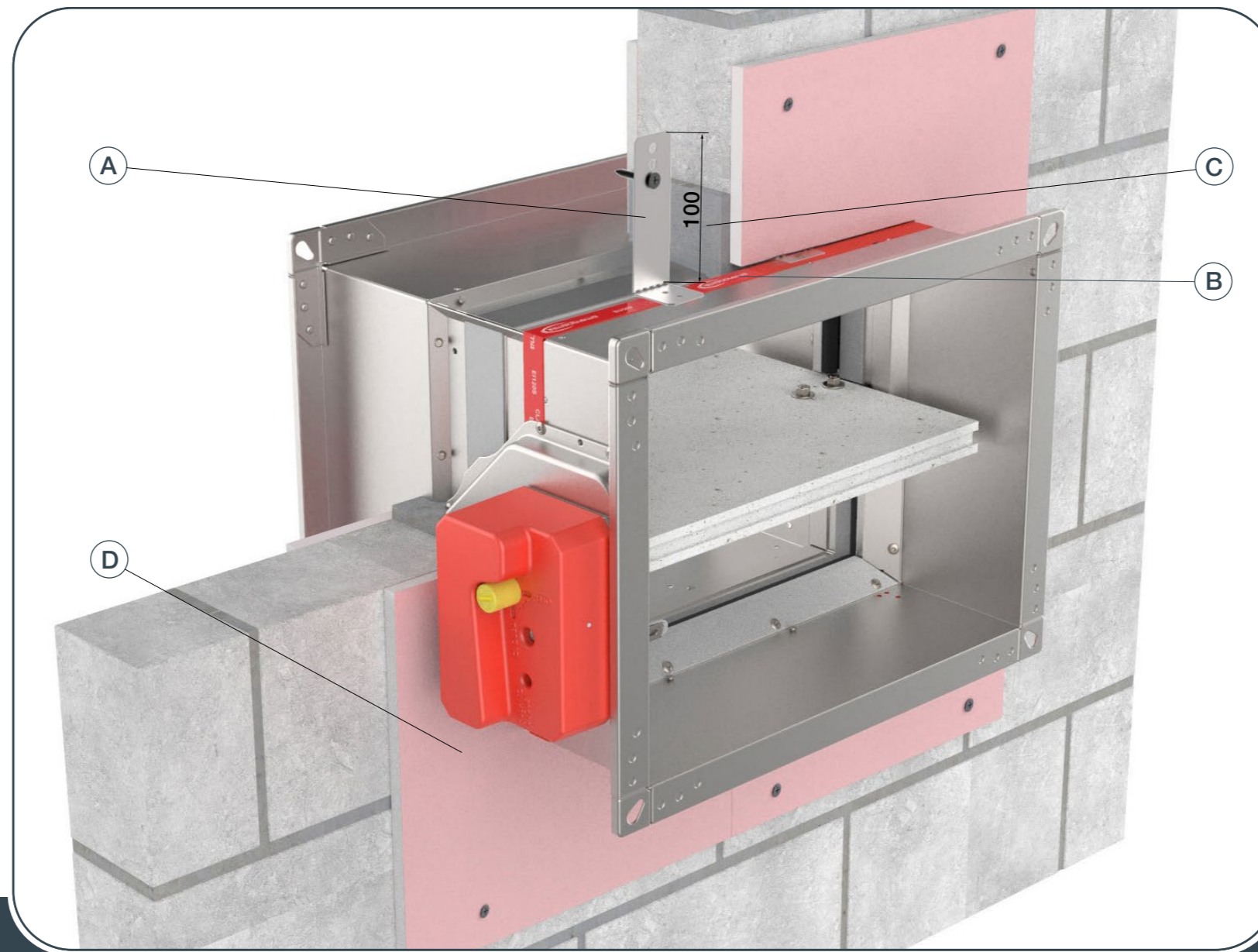

- ▼ PRODUCT OVERVIEW
- ▼ DIMENSIONS
- ▼ INSTALLATIONS
- ▼ ACTUATORS
- ▼ ACCESSORIES
- ▼ REPLACEMENTS
- ▼ MAINTENANCE AND OPERATION

Possible damper orientations



FIRE DAMPER - FD

**Always ensure the damper is sufficiently supported and a breakaway joint is incorporated between the damper and adjoining ductwork on both sides**

1. Recommended wall opening for the fire damper installation is B (H) + 80 mm or more (up to 50% more).

**Damper blade must be closed during the installation!**

2. Bend the fixing bracket (A) 90° (bracket screw hole is 6 mm in diameter). Place the damper in the opening up to the wall limit mark (B) on the damper.

3. Fill the space between casing and wall with mortar (C).

4. Cover the mortar with GKF gypsum boards (D) (12,5 mm thick).

\*Multiple fire dampers can be installed next to each other or ceiling/wall with the minimal distance as shown on [page 52](#).

\*Build the support for installation according to the drawing, [see page 53](#).  
**Test the operation of the damper blade!**

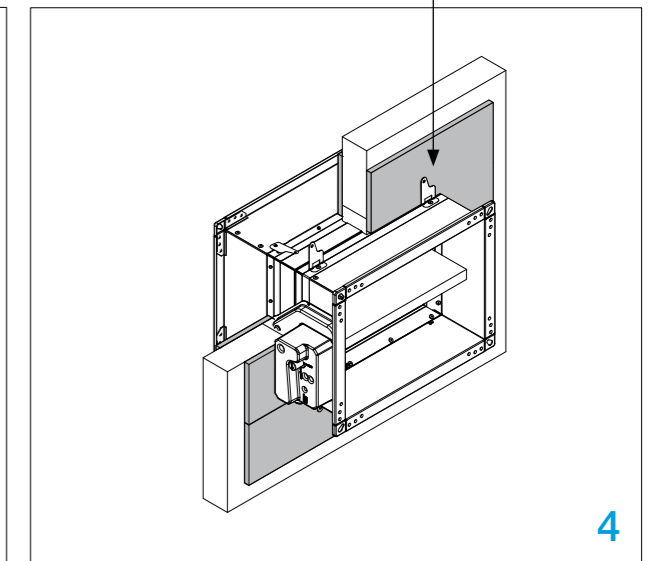
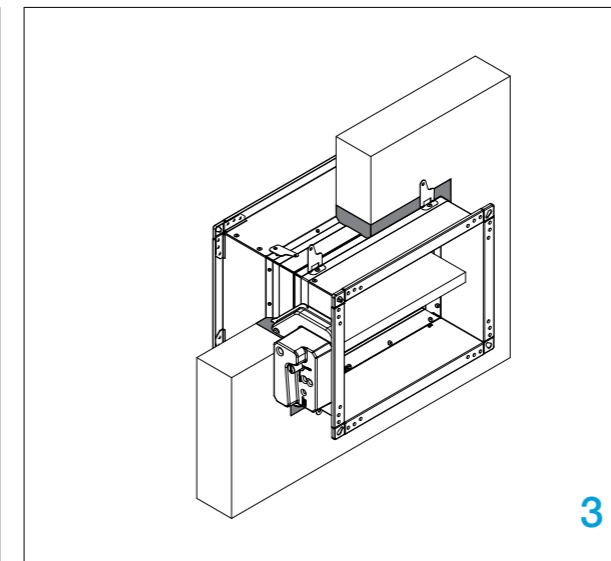
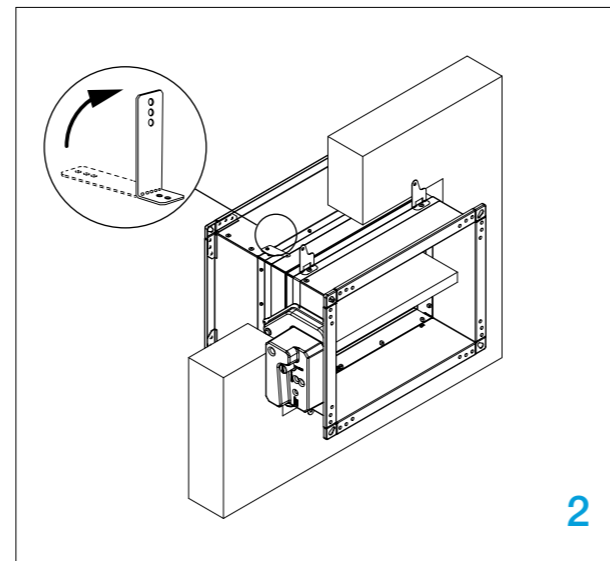
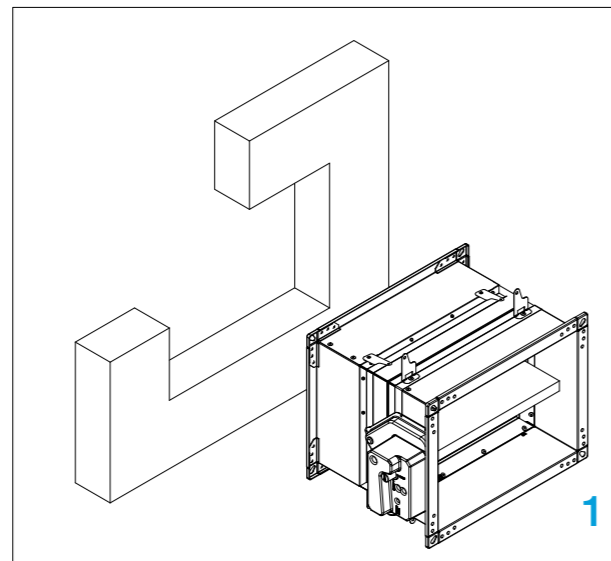

FD-A-CSP-BxH  
For more details see [pg.59](#)

## Flexible wall installation (mortar sealing)

The wall is composed of 2x2 plasterboard boards, 12,5 mm thick, installed on a steel frame construction. Installation material: gypsum plaster or mortar (C) covered with type F(EI 120) or type A(EI 60) cover boards (D). The minimum thickness of the wall is 100 mm.

### EI 120 (ve i↔o)S

The wall is made out of type F (EN520) gypsum plaster boards. To fulfill the classification it is **NOT** mandatory to use the mineral wool inside the wall (mineral wool (E) with density up to 100 kg/m<sup>3</sup> can be used).

### EI 60 (ve i↔o)S

The wall is made out of type A (EN520) gypsum plaster boards. To fulfill the classification it is **NOT** mandatory to use the mineral wool inside the wall (mineral wool (E) with density up to 60 kg/m<sup>3</sup> can be used).

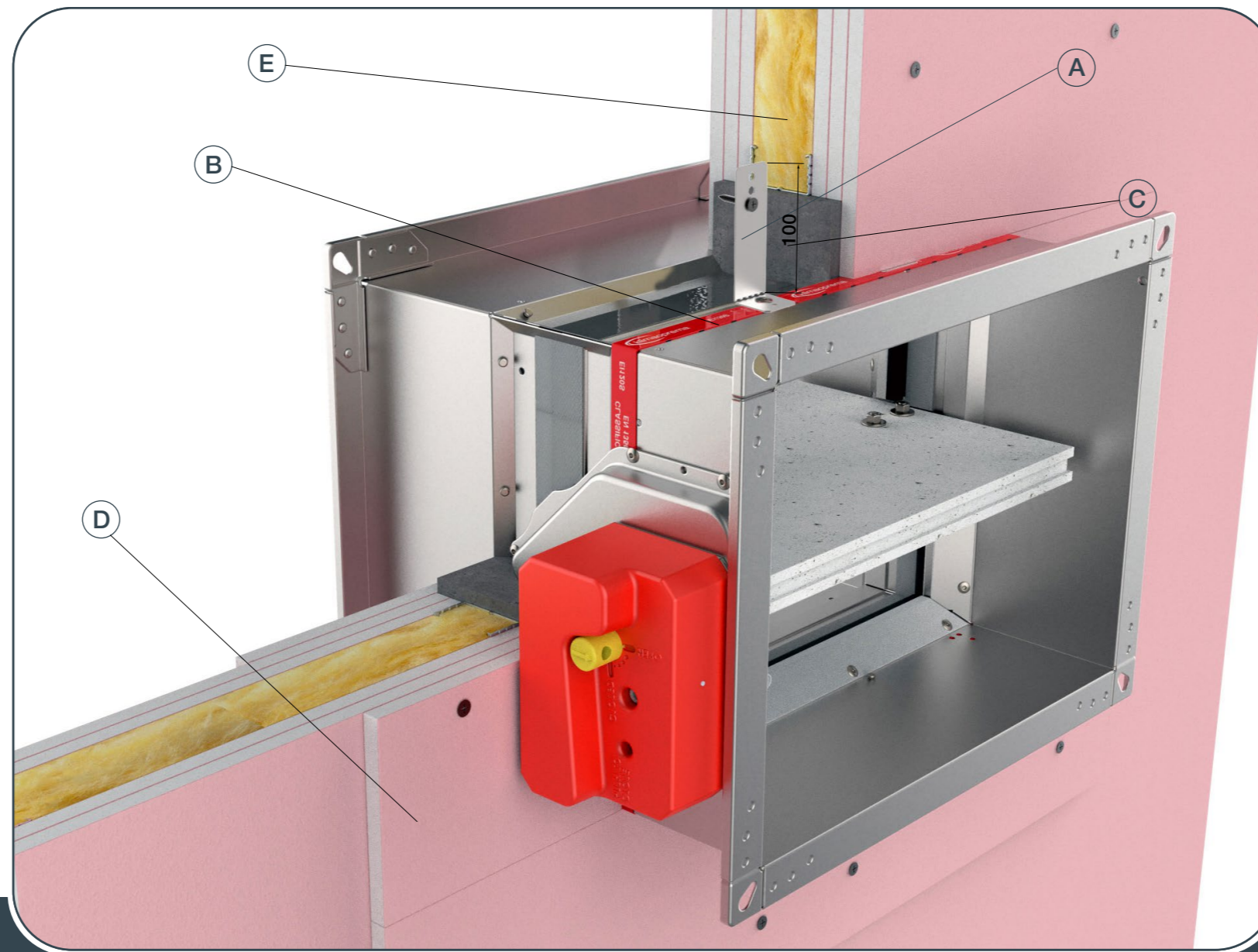

- ▼ [PRODUCT OVERVIEW](#)
- ▼ [DIMENSIONS](#)
- ▼ [INSTALLATIONS](#)
- ▼ [ACTUATORS](#)
- ▼ [ACCESSORIES](#)
- ▼ [REPLACEMENTS](#)
- ▼ [MAINTENANCE AND OPERATION](#)

Possible damper orientations



## INSTALLATION

FIRE DAMPER - FD

**Always ensure the damper is sufficiently supported and a breakaway joint is incorporated between the damper and adjoining ductwork on both sides**

1. Recommended wall opening for the fire damper installation is B (H) + 80 mm or more (up to 50% more). Build the subframe according to the drawing, [see page 53](#). Bend the fixing bracket (A) 90°. Place the damper in the opening up to the wall limit mark (B) on the damper.

**Damper blade must be closed during the installation!**

2. Fix the damper to the wall using self-tapping screws Ø3,5x45 mm (bracket screw hole is 6 mm in diameter).

3. Fill the space between the damper and the wall with mortar sealing (C). Cover the mortar with (D) GKF gypsum boards (12,5 mm thick, FD-A-CSP-BxH).

\*Multiple fire dampers can be installed next to each other or ceiling/wall with the minimal distance as shown on [page 52](#).

\*Build the support for mortar installation according to the drawing, [see page 53](#).

**Test the operation of the damper blade!**

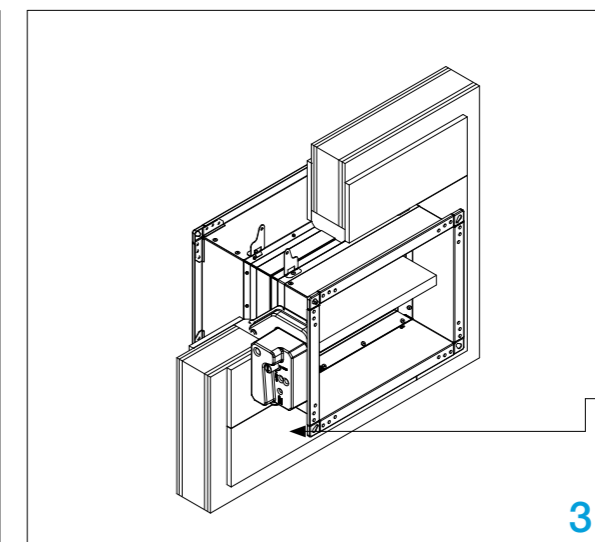
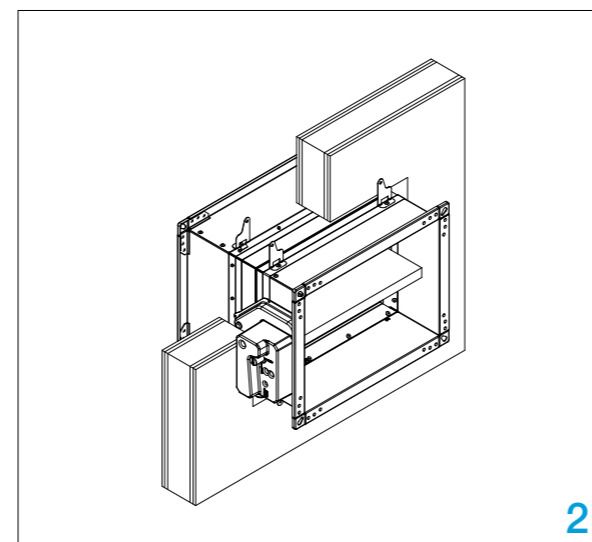
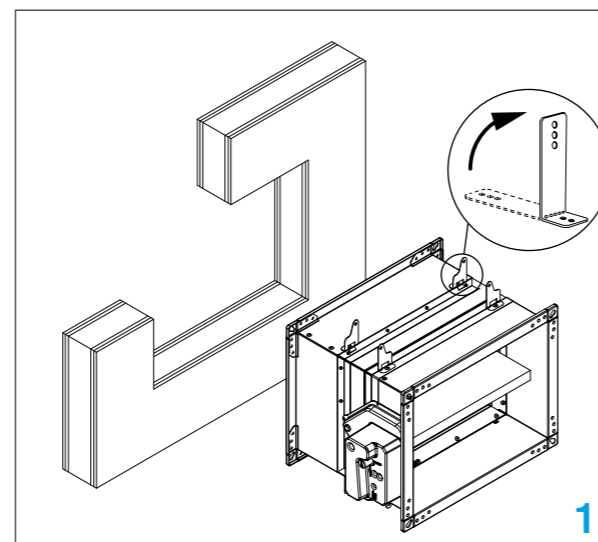

FD-A-CSP-BxH  
For more details see [pg.59](#)

## Flexible wall installation (mortar sealing)

The wall is composed of 2x2 plasterboard boards, 12,5 mm thick, installed on a steel frame construction. Installation material: gypsum plaster or mortar (C). The minimum thickness of the wall is 100 mm.

### EI 120 (ve i↔o)S

The wall is made out of type F (EN520) gypsum plaster boards. To fulfill the classification it is **NOT** mandatory to use the mineral wool inside the wall (mineral wool (E) with density up to 100 kg/m<sup>3</sup> can be used).

### EI 60 (ve i↔o)S

The wall is made out of type A (EN520) gypsum plaster boards. To fulfill the classification it is **NOT** mandatory to use the mineral wool inside the wall (mineral wool (E) with density up to 60 kg/m<sup>3</sup> can be used).



## INSTALLATION

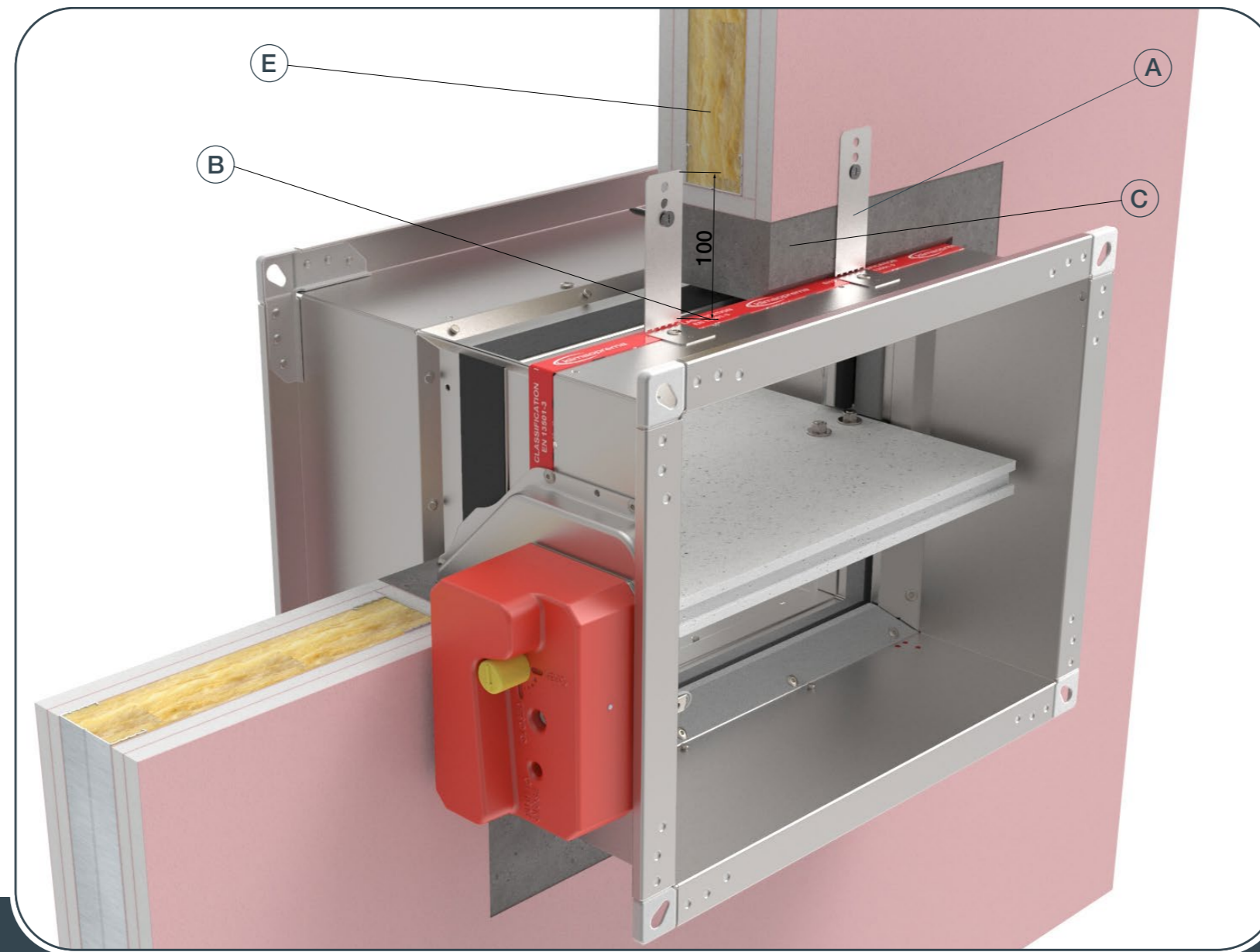

- ▼ PRODUCT OVERVIEW
- ▼ DIMENSIONS
- ▼ INSTALLATIONS
- ▼ ACTUATORS
- ▼ ACCESSORIES
- ▼ REPLACEMENTS
- ▼ MAINTENANCE AND OPERATION

Possible damper orientations



FIRE DAMPER - FD

**Always ensure the damper is sufficiently supported and a breakaway joint is incorporated between the damper and adjoining ductwork on both sides**

1. Recommended wall opening for the fire damper installation is FD25 B (H) + 105 mm, FD40 B (H) + 120 mm or more (up to 50% more). Build the subframe according to the drawing, [see page 53](#). Bend the fixing bracket (A) 90°. Place the damper in the opening up to the wall limit mark (B) on the damper.

**Damper blade must be closed during the installation!**

2. Fix the damper to the wall using self-tapping screws Ø3,5x45 mm (bracket screw hole is 6 mm in diameter).

3. Fill the space between the damper and the wall with mortar sealing (C).

\*Multiple fire dampers can be installed next to each other or ceiling/wall with the minimal distance as shown on [page 52](#).

\*Build the support for mortar installation according to the drawing, [see page 53](#).

**Test the operation of the damper blade!**

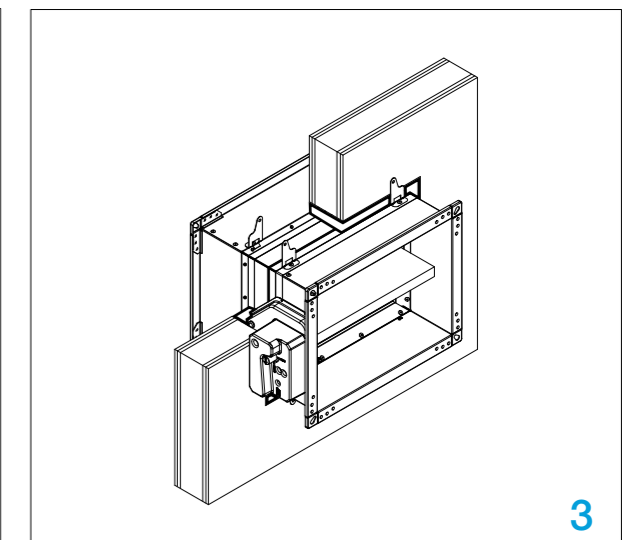
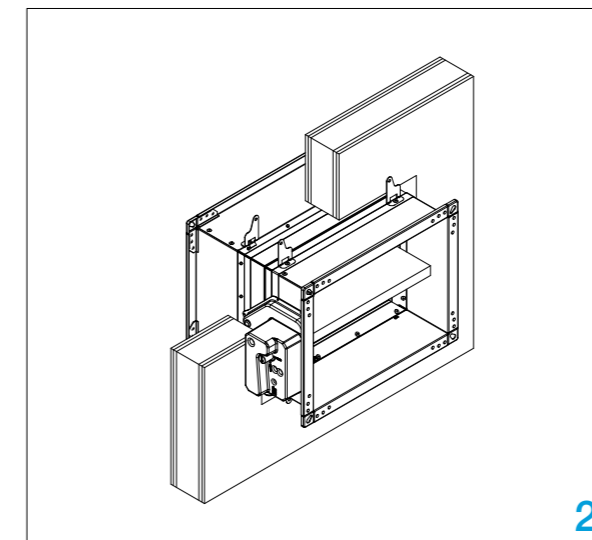
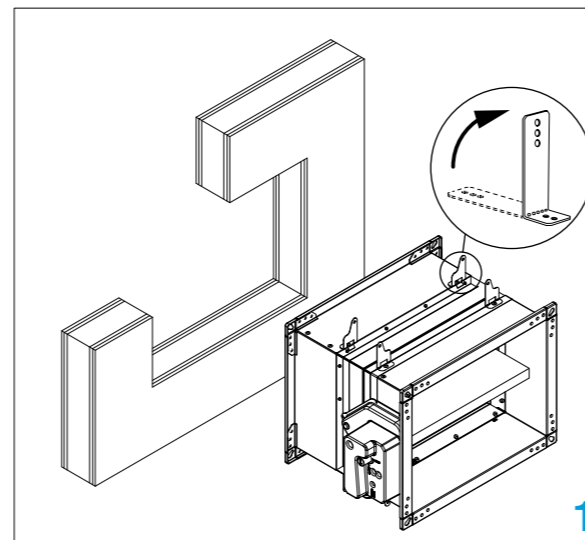

## Flexible wall installation (mineral wool sealing)

The wall is composed of 2x2 plasterboard boards, 12,5 mm thick, installed on a steel frame construction. Installation material: mineral wool (C) (minimum density of 100 kg/m<sup>3</sup>) covered with type F(EI 120) or type A(EI 60) cover boards (D). The minimum thickness of the wall is 100 mm.

### EI 90 (ve i↔o)S

The wall is made out of type F (EN520) gypsum plaster boards. To fulfill the classification it is **NOT** mandatory to use the mineral wool inside the wall (mineral wool (E) with density up to 100 kg/m<sup>3</sup> can be used).

### EI 60 (ve i↔o)S

The wall is made out of type A (EN520) gypsum plaster boards. To fulfill the classification it is **NOT** mandatory to use the mineral wool inside the wall (mineral wool (E) with density up to 60 kg/m<sup>3</sup> can be used).

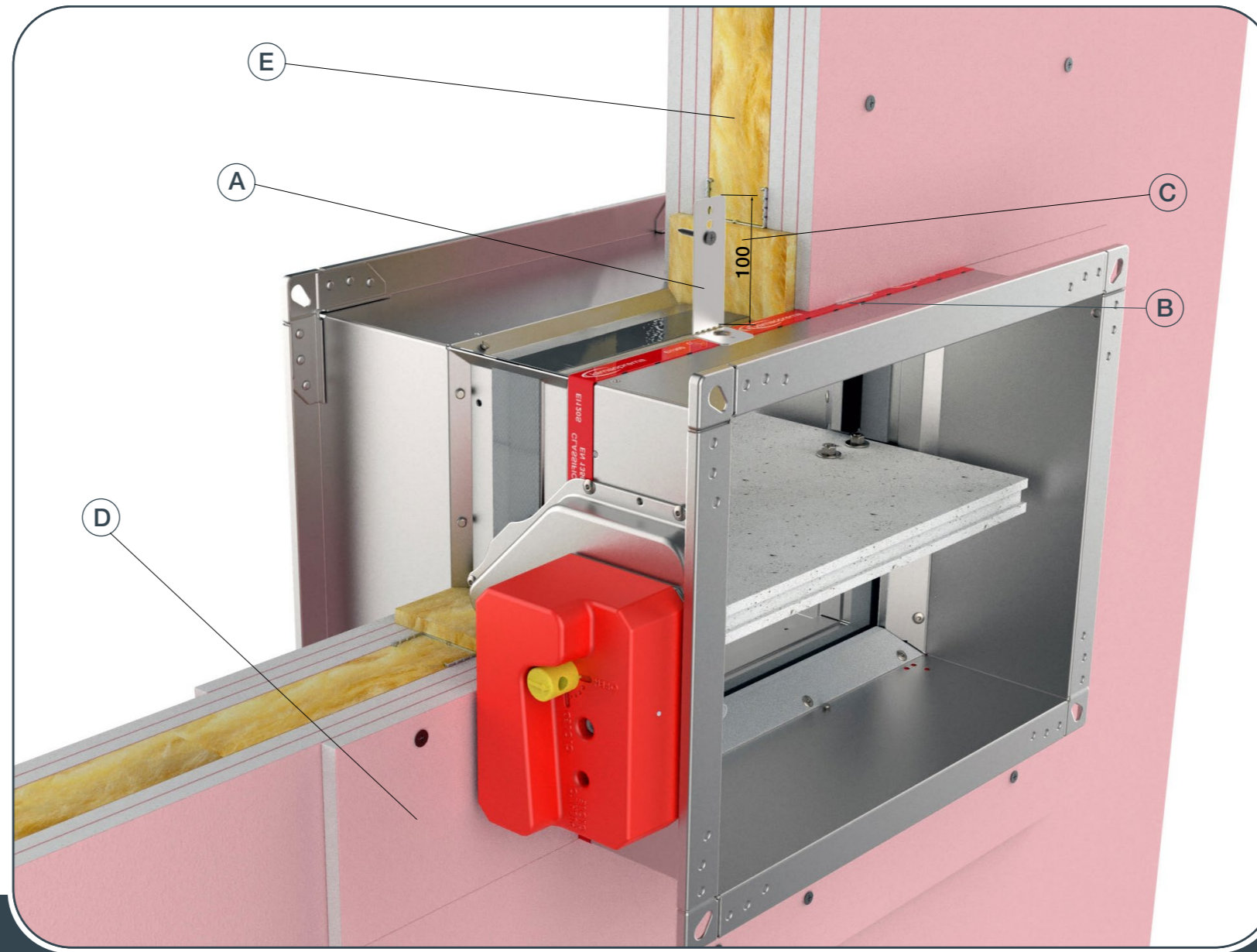

- ▼ PRODUCT OVERVIEW
- ▼ DIMENSIONS
- ▼ INSTALLATIONS
- ▼ ACTUATORS
- ▼ ACCESSORIES
- ▼ REPLACEMENTS
- ▼ MAINTENANCE AND OPERATION

Possible damper orientations



## INSTALLATION

## FIRE DAMPER - FD

**Always ensure the damper is sufficiently supported and a breakaway joint is incorporated between the damper and adjoining ductwork on both sides**

1. Recommended wall opening for the fire damper installation is B (H) + 80 mm or more (up to 50% more). Build the subframe according to the drawing, [see page 53](#). Bend the fixing bracket (A) 90°. Place the damper in the opening up to the wall limit mark (B) on the damper.

**Damper blade must be closed during the installation!**

2. Fix the damper to the wall using self-tapping screws Ø3,5x45 mm (bracket screw hole is 6 mm in diameter).

3. Fill the space between the damper and the wall with mineral wool (C). Cover the mineral wool with GKF gypsum boards (12,5 mm thick) (D) and fix them with self-tapping screws Ø3,5x45 mm.

\*Multiple fire dampers can be installed next to each other or ceiling/wall with the minimal distance as shown on [page 52](#).

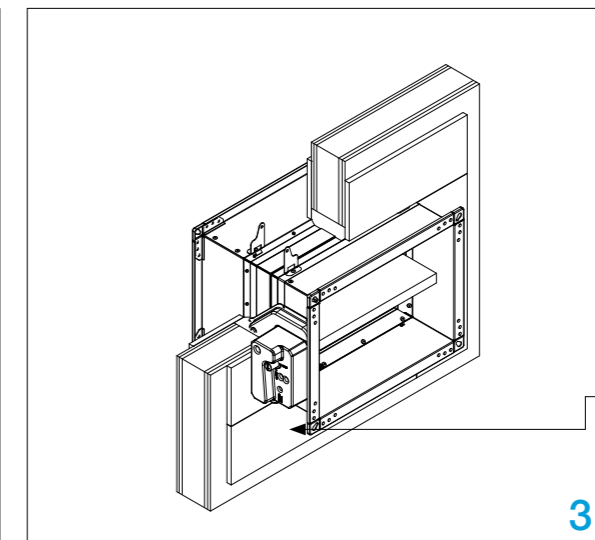
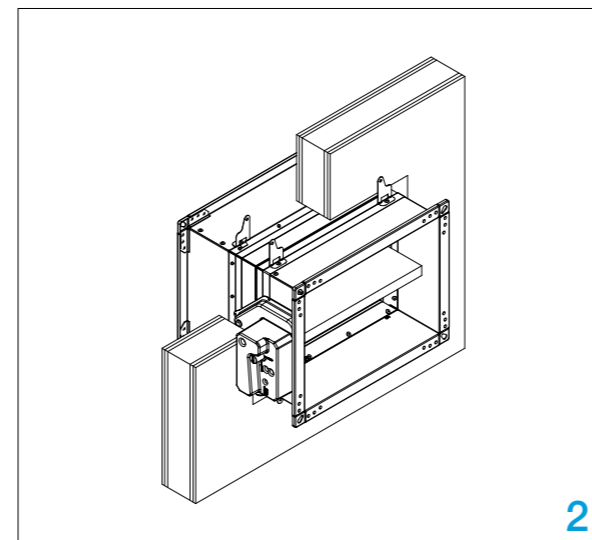
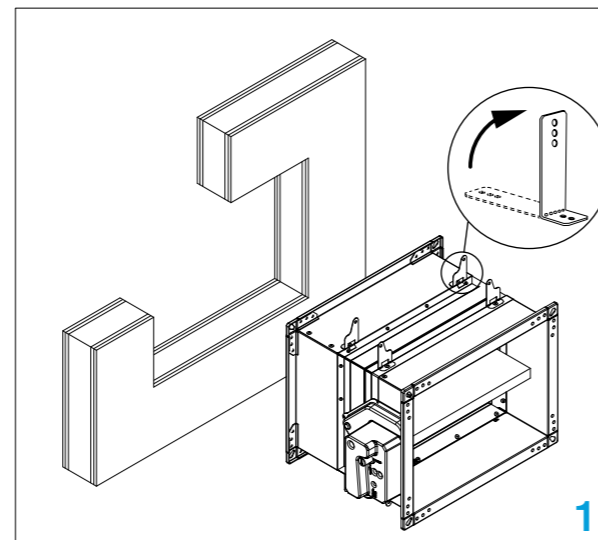

FD-A-CSP-BxH  
For more details see [pg.59](#)

**Test the operation of the damper blade!**

## Flexible wall installation (Fire Batt/ Weichschott)

The wall is composed of 2x2 plasterboard boards, 12,5 mm thick, installed on a steel frame construction. Installation material: mineral wool (C) (minimum density of 140 kg/m<sup>3</sup>) and fire protection coating (D). The minimum thickness of the wall is 100 mm.

### EI 90 (ve i↔o)S

The wall is made out of type F (EN520) gypsum plaster boards. To fulfill the classification it is **NOT** mandatory to use the mineral wool inside the wall (mineral wool (E) with density up to 100 kg/m<sup>3</sup> can be used).

### EI 60 (ve i↔o)S

The wall is made out of type A (EN520) gypsum plaster boards. To fulfill the classification it is **NOT** mandatory to use the mineral wool inside the wall (mineral wool (E) with density up to 60 kg/m<sup>3</sup> can be used).



with density up to 60 kg/m<sup>3</sup> can be used).

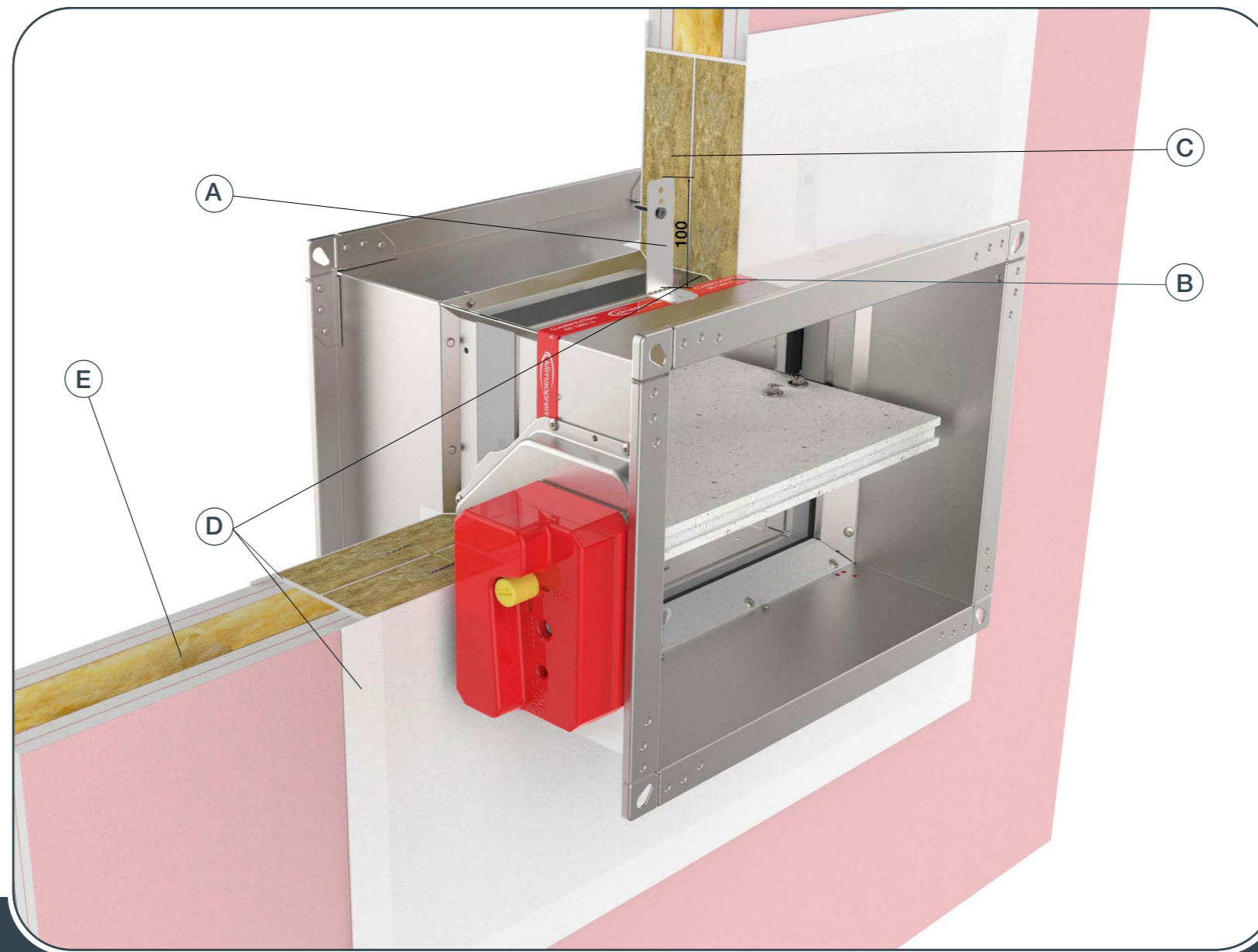

- ▼ [PRODUCT OVERVIEW](#)
- ▼ [DIMENSIONS](#)
- ▼ [INSTALLATIONS](#)
- ▼ [ACTUATORS](#)
- ▼ [ACCESSORIES](#)
- ▼ [REPLACEMENTS](#)
- ▼ [MAINTENANCE AND OPERATION](#)

Possible damper orientations



INSTALLATION

FIRE DAMPER - FD

**Always ensure the damper is sufficiently supported and a breakaway joint is incorporated between the damper and adjoining ductwork on both sides**

1. Recommended wall opening for fire damper installation is B(H) + 300 mm, but openings from B(H) + 80...450 mm can also be used. Build the subframe according to the drawing, [see page 53](#). Bend the fixing bracket (A) 90° (bracket screw hole is 6 mm in diameter).

2. Insert fire damper into wall to the wall limit mark (B) on the damper.

**Damper blade must be closed during installation!**

3. Fill the space between casing and wall, close with two layers of mineral wool (C) (50 mm thick, coated on one side). Seal the connections of mineral wool with intumescent fire resistant sealant (D). Mineral wool and damper casing must be coated with 2 mm thick fire protection coating. Damper casing

should be coated up to profile flanges.

\*Multiple fire dampers can be installed next to each other or ceiling/wall with the minimal distance as shown on [page 52](#).

\*\*Fire Batt/ Weichschott installations adjacent to ceiling or wall require a suspension for the fire damper. For more details, [see page 37](#).

**Test the operation of the damper blade!**

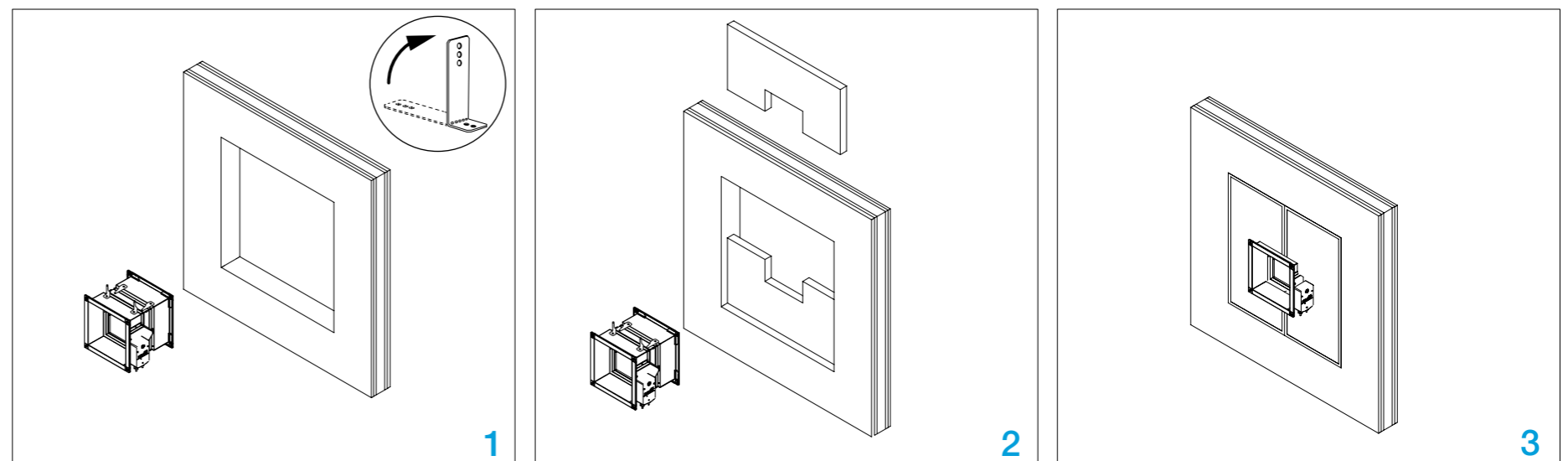

## Flexible wall installation-75mm (Fire Batt/ Weichschott)

The wall is composed of 1x1 plasterboard boards, 12,5 mm thick, installed on a steel frame construction. Installation material: mineral wool (C) (minimum density of 140 kg/m<sup>3</sup>) and fire protection coating (D). The minimum thickness of the wall is 75 mm.

### EI 45(ve i↔o)S

The wall is made out of type F (EN520) gypsum plaster boards. To fulfill the classification it is **NOT** mandatory to use the mineral wool inside the wall (mineral wool (E) with density up to 115 kg/m<sup>3</sup> can be used).



## INSTALLATION

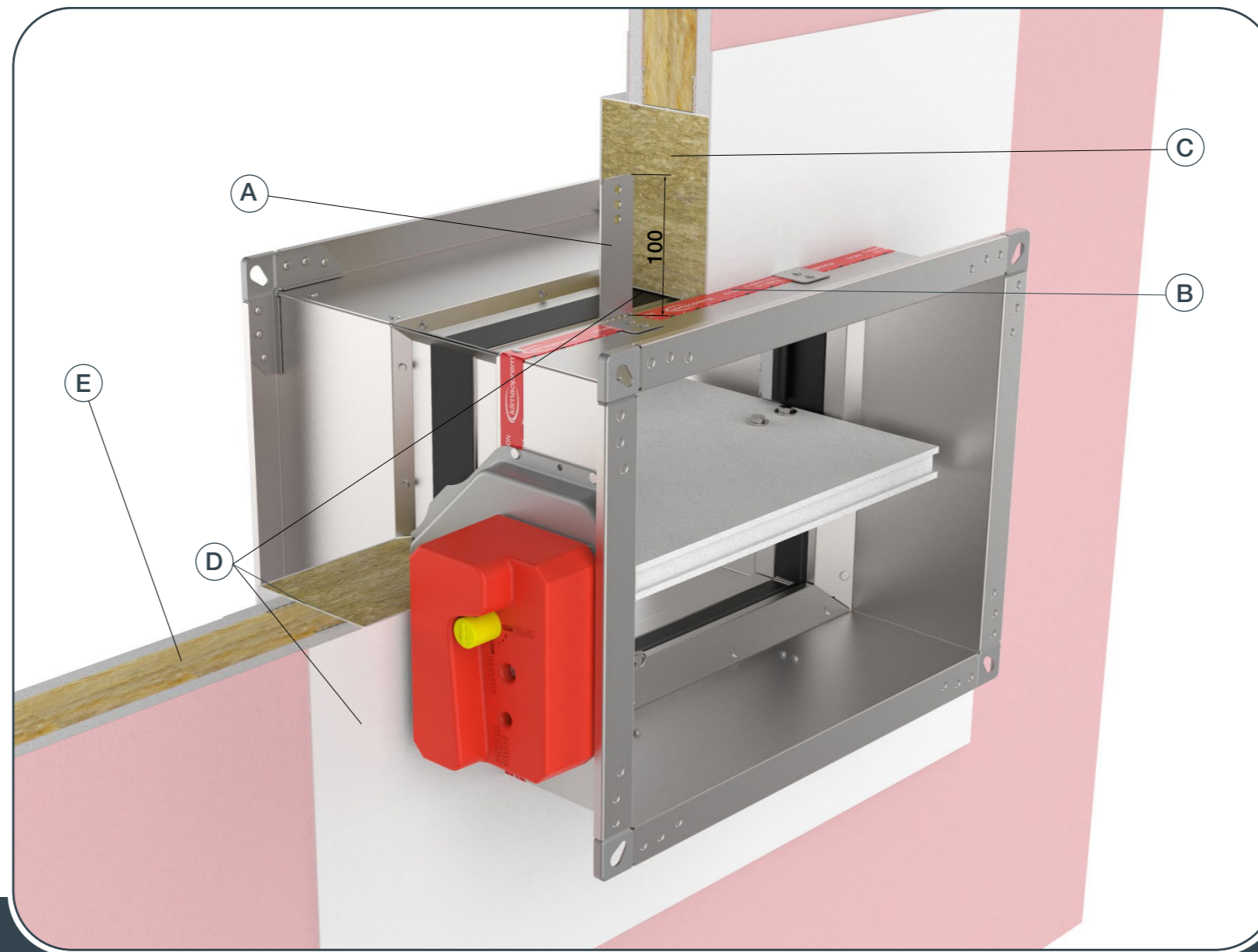

- ▼ [PRODUCT OVERVIEW](#)
- ▼ [DIMENSIONS](#)
- ▼ [INSTALLATIONS](#)
- ▼ [ACTUATORS](#)
- ▼ [ACCESSORIES](#)
- ▼ [REPLACEMENTS](#)
- ▼ [MAINTENANCE AND OPERATION](#)

Possible damper orientations



FIRE DAMPER - FD

**Always ensure the damper is sufficiently supported and a breakaway joint is incorporated between the damper and adjoining ductwork on both sides**

1. Recommended wall opening for fire damper installation is B(H) + 300 mm, but openings from B(H) + 80...450 mm can also be used. Build the subframe according to the drawing, [see page 53](#). Bend the fixing bracket (A) 90° (bracket screw hole is 6 mm in diameter).

2. Insert fire damper into wall to the wall limit mark (B) on the damper.

**Damper blade must be closed during installation!**

3. Fill the space between casing and wall, close with two layers of mineral wool (C) (50 mm thick, coated on one side). On the side opposite the drive, leave the wool 25 mm outside the wall.

Seal the connections of mineral wool with intumescent fire resistant sealant (D). Mineral wool and damper casing

must be coated with 2 mm thick fire protection coating. Damper casing should be coated up to profile flanges.

\*Multiple fire dampers can be installed next to each other or ceiling/wall with the minimal distance as shown on [page 52](#).

\*\*Fire Batt/ Weichschott installations adjacent to ceiling or wall require a suspension for the fire damper. For more details, [see page 37](#).

**Test the operation of the damper blade!**

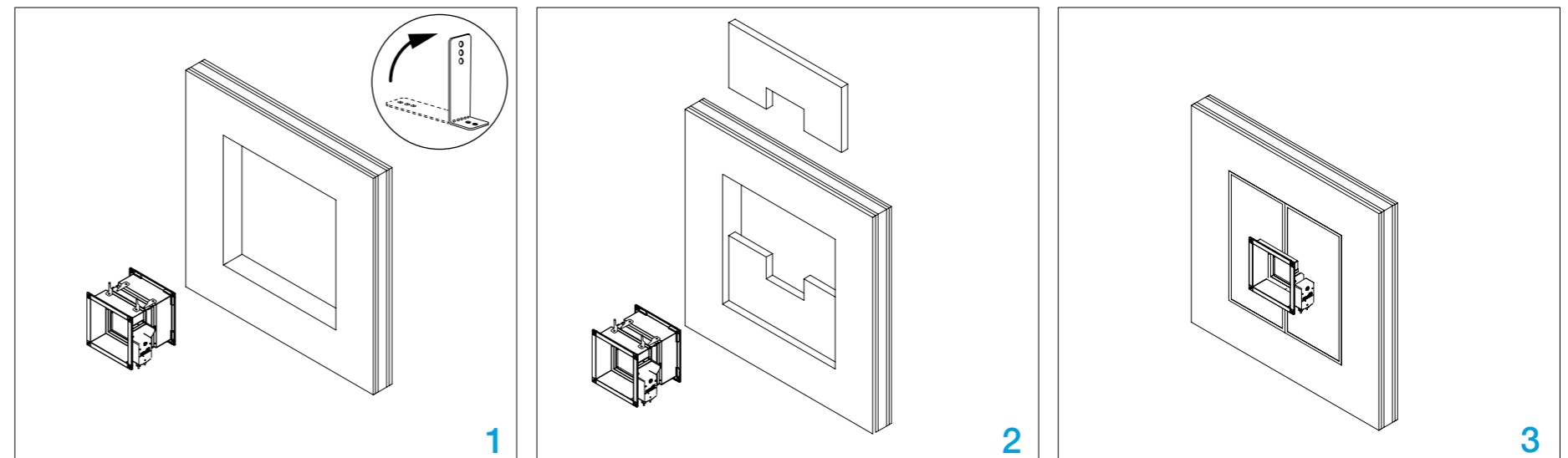

## Flexible wall installation CLT wall (Fire Batt/ Weichschott)

Fire dampers are mounted in CLT (Cross laminated timber) wooden wall with density 480 kg/m<sup>3</sup>. Wall is made of 3 layers (30 – 40 – 30 mm).

### EI 90 (ve i↔o)S

Installation material: Mineral wool (minimum density of 140 kg/m<sup>3</sup>, fire protection coating).



## INSTALLATION

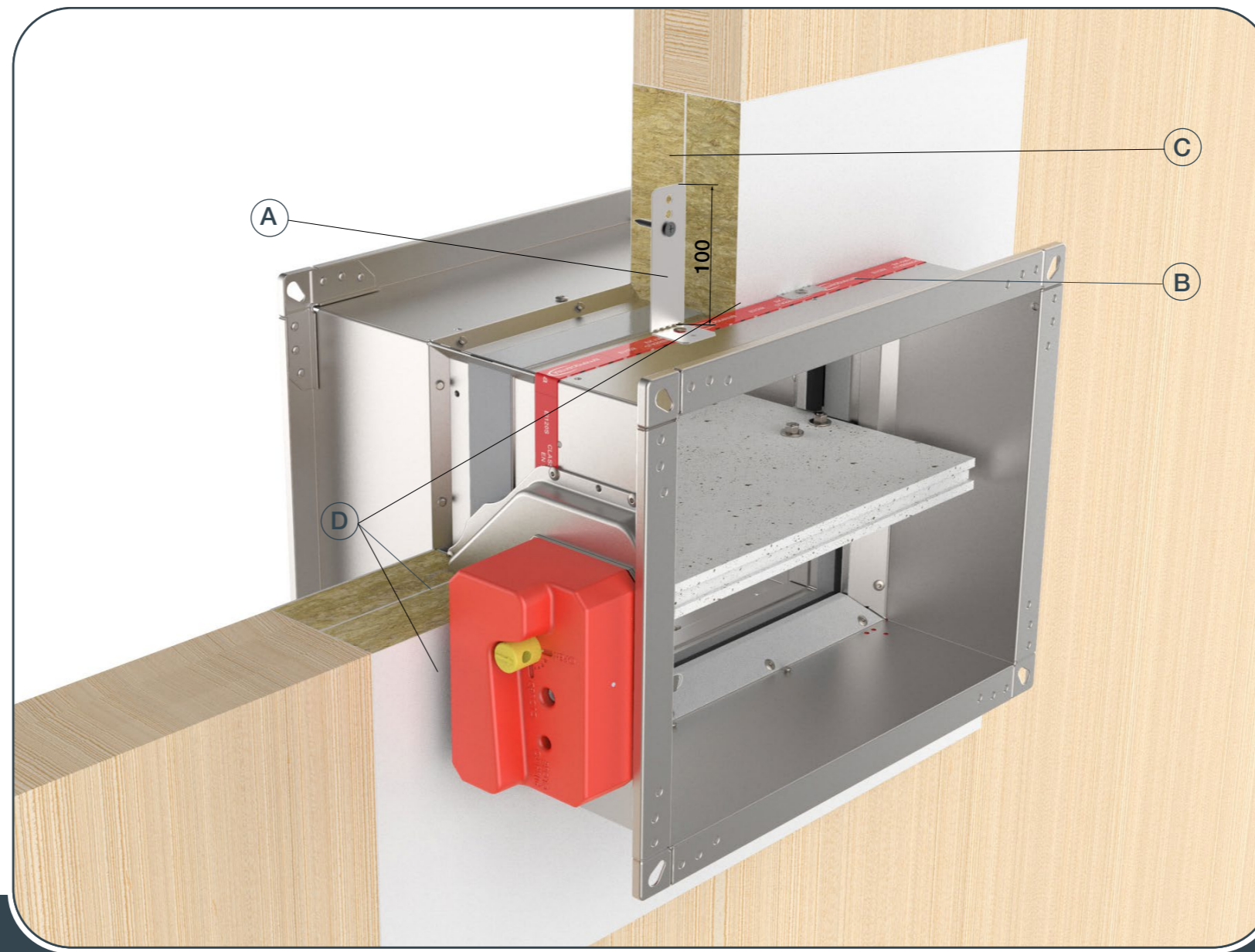

- ▼ [PRODUCT OVERVIEW](#)
- ▼ [DIMENSIONS](#)
- ▼ [INSTALLATIONS](#)
- ▼ [ACTUATORS](#)
- ▼ [ACCESSORIES](#)
- ▼ [REPLACEMENTS](#)
- ▼ [MAINTENANCE AND OPERATION](#)

Possible damper orientations



FIRE DAMPER - FD

**Always ensure the damper is sufficiently supported and a breakaway joint is incorporated between the damper and adjoining ductwork on both sides**

1. Recommended wall opening for fire damper installation is B(H) + 40...300 mm, but openings from B(H) + 80...450 mm can also be used. Bend the fixing bracket **(A)** 90° (bracket screw hole is 6 mm in diameter).

2. Insert fire damper into wall to the wall limit mark **(B)** on the damper.

**Damper blade must be closed during installation!**

3. Fill the space between casing and wall, close with two layers of mineral wool **(C)** (50 mm thick, coated on one side). Seal the connections of mineral

wool with intumescent fire resistant sealant **(D)**. Mineral wool and damper casing must be coated with 2 mm thick fire protection coating. Damper casing should be coated up to profile flanges.

**Test the operation of the damper blade!**

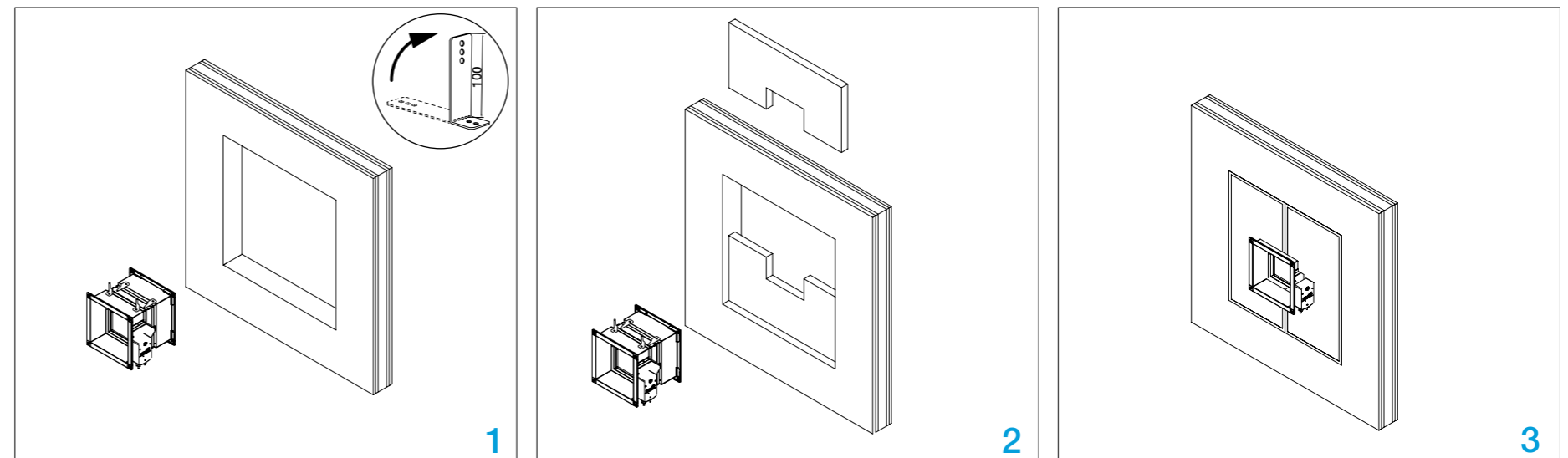

## Flexible wall installation Eurobond

The wall is composed of Eurobond Firemaster boards, in 100 mm thickness, installed in a steel frame construction.

**FD 25 EI 60 (i↔o)S**

**FD 40 EI 60 (i↔o)S**

Sealing between dampers and wall is 2 layers of Rockwool Firepro 50 mm thick sealed with intumescent fire resistant sealant.



### INSTALLATION

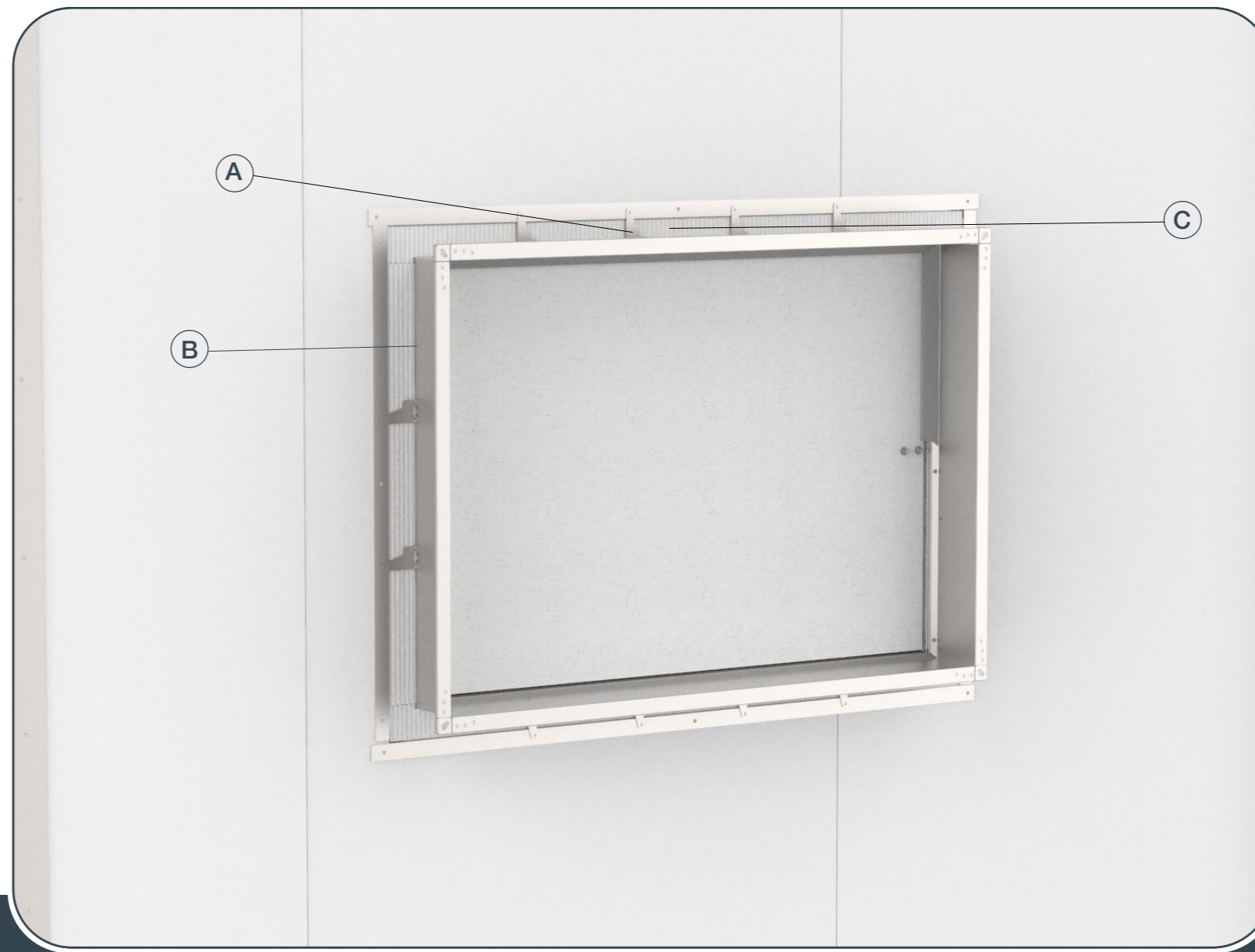

- ▼ [PRODUCT OVERVIEW](#)
- ▼ [DIMENSIONS](#)
- ▼ [INSTALLATIONS](#)
- ▼ [ACTUATORS](#)
- ▼ [ACCESSORIES](#)
- ▼ [REPLACEMENTS](#)
- ▼ [MAINTENANCE AND OPERATION](#)

Possible damper orientations



FIRE DAMPER - FD

**Always ensure the damper is sufficiently supported and a breakaway joint is incorporated between the damper and adjoining ductwork on both sides**

Create the wall. See [technical drawing](#).

1. Make the opening in the wall B + 120 mm x H + 120 mm on the connection of two boards. The opening is re-inforced with L profiles 30x30x2mm and screws 6,3x25 on one sides and 6,3x120mm on other side.

The opening must be coated with 2 mm thick fire protection coating.

2. Place the damper in the opening up to the wall limit mark (B) on the damper.

**Damper blade must be closed during installation!**

3. Close the space between casing and wall with two layers of mineral wool (C) (50 mm thick, coated on one side). Seal the connections of mineral wool with intumescent fire resistant sealant. Mineral wool and damper casing must be coated with 2 mm thick fire protection coating. Damper casing should be coated up to profile protrusions.

**Test the operation of the damper blade!**



## Flexible wall installation Eurobond Battery 2x2

The wall is composed of Eurobond Firemaster wall panels, in 100 mm thickness, stabled in a steel frame construction.

### FD 40 EI 90 (i↔o)S

Sealing between dampers and wall is 2 layers of Rockwool Firepro 50 mm thick sealed with intumescent fire resistant sealant.



## INSTALLATION



- ▼ [PRODUCT OVERVIEW](#)
- ▼ [DIMENSIONS](#)
- ▼ [INSTALLATIONS](#)
- ▼ [ACTUATORS](#)
- ▼ [ACCESSORIES](#)
- ▼ [REPLACEMENTS](#)
- ▼ [MAINTENANCE AND OPERATION](#)

Possible damper orientations



FIRE DAMPER - FD

**Always ensure the damper is sufficiently supported and a breakaway joint is incorporated between the damper and adjoining ductwork on both sides**

1. Prepare a hole of dimensions 2B + Connecting frame width (CF60/CF100) + 80 mm and 2H + Connecting frame width (CF60/CF100) + 80 mm on the connection of two boards. The opening is re-inforced with L profiles and screws 6,3x25 on one sides and 6,3x120mm on other side and coated with 2 mm thick fire protection coating. Install [suspension](#).

2. Place two lower dampers in the opening/ on the suspension, and fix dampers to the wall using screws. Place the vertical part from the installation kit to the dampers on both sides, and attach it using the self-tapping screws. Fill the space between the dampers and the wall with two layers of mineral wool, (23 kg/m<sup>3</sup> of density or higher) **Damper blade must be closed during installation!**

3. Place two upper dampers and fix the dampers to the wall using the screws. Fill the space between the dampers and the wall with mineral wool.

4. Place the vertical part and two horizontal parts from the installation kit to the dampers on both sides, and attach it using the self-tapping screws every 150 mm. Fill the gap between dampers and wall on upper side with mineral wool and seal the connections of mineral wool with intumescent fire resistant sealant up to profile protrusions. **Test the operation of the damper blade!**

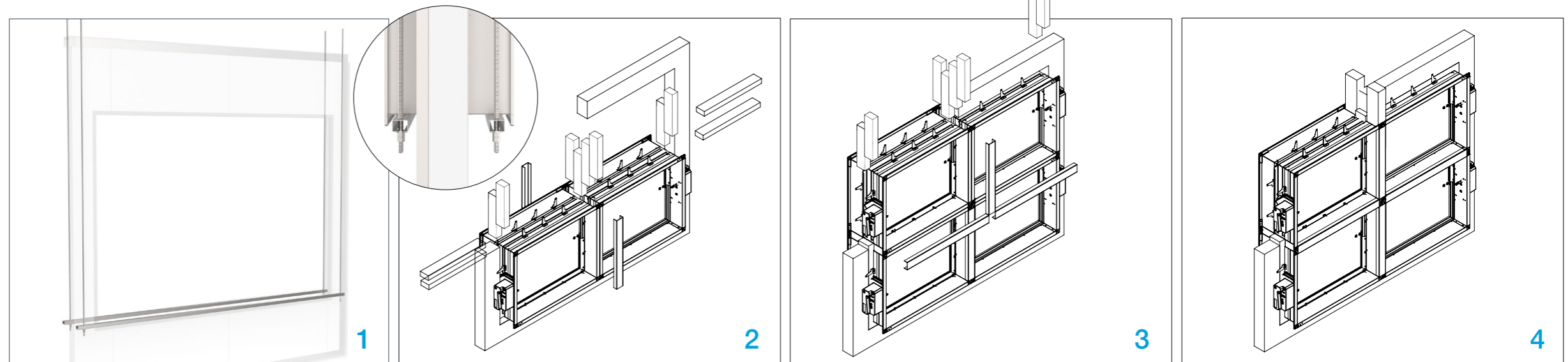







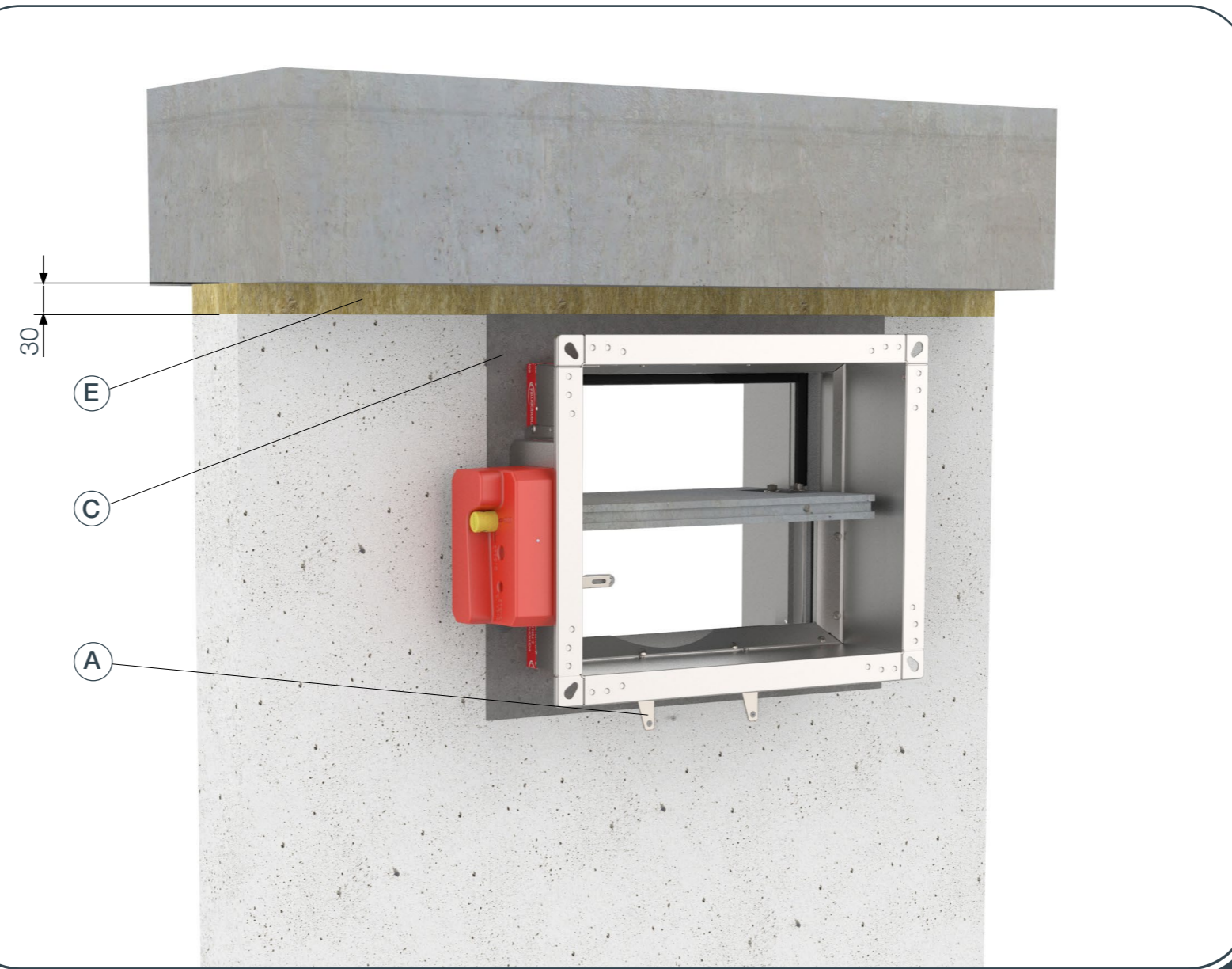

## Flexible ceiling joint Gypsum blocks flexibile wall

The wall is composed out of gypsum blocks (minimum density of 450 kg/m<sup>3</sup>) and with minimum thickness of 100 mm. Installation material is gypsum plaster (C) and mineral wool (70 kg/m<sup>3</sup>) (E), thickness of the wool is 40 mm.



### INSTALLATION



-  [PRODUCT OVERVIEW](#)
-  [DIMENSIONS](#)
-  [INSTALLATIONS](#)
-  [ACTUATORS](#)
-  [ACCESSORIES](#)
-  [REPLACEMENTS](#)
-  [MAINTENANCE AND OPERATION](#)

Possible damper orientations

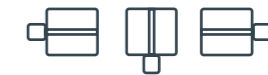

FIRE DAMPER - FD

**Always ensure the damper is sufficiently supported and a breakaway joint is incorporated between the damper and adjoining ductwork on both sides**

1. Create an opening in the wall B + 80...300 mm x H + 80 mm, 30mm below the ceiling.
2. Insert the fire damper into the opening and fix the mounting bracker with self tapping screw (3,5 x 35 mm)
3. Fill the space between the damper and the wall with gypsum plaster/ mortar.
4. Fill the space between the ceiling and the wall with mineral wool (70 kg/m<sup>3</sup>, thickness 40 mm).

**Damper blade must be closed during installation!**

**Test the operation of the damper blade!**

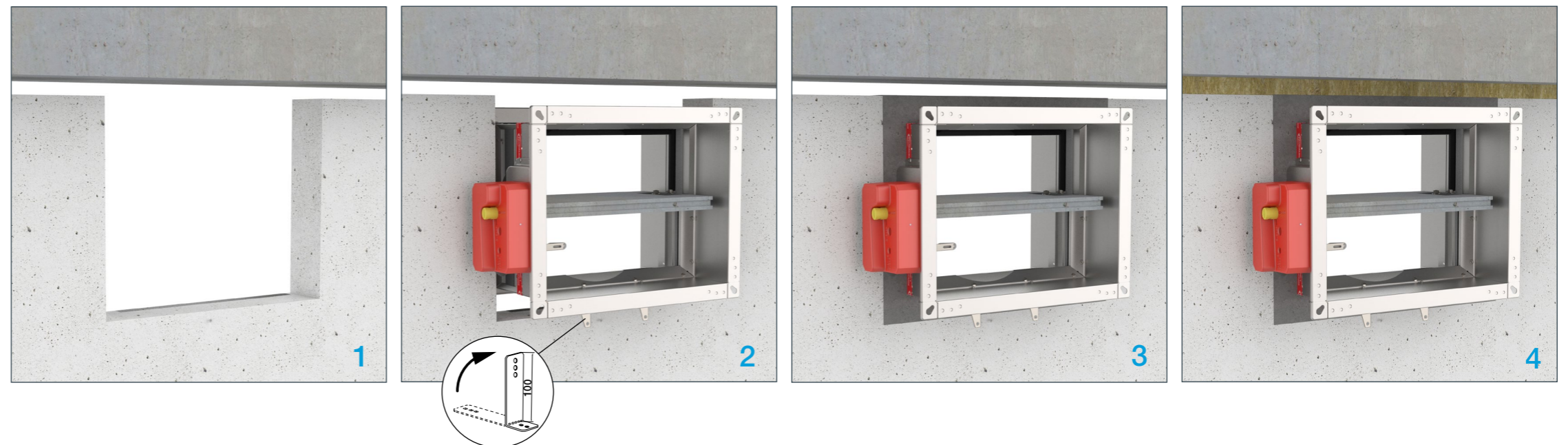



## Flexible ceiling joint Plasterboard type F wall

The wall is composed of 2x2 plasterboard boards, 12,5 mm thick, installed on a steel frame construction. To fulfill the classification it is **NOT** mandatory to use the mineral wool inside the wall (mineral wool with density up to 100 kg/m<sup>3</sup> can be used). The minimum thickness of the wall is 100 mm. Installation material is gypsum plaster (C) and mineral wool (115 kg/m<sup>3</sup>) (E), thickness of the wool is 50 mm.

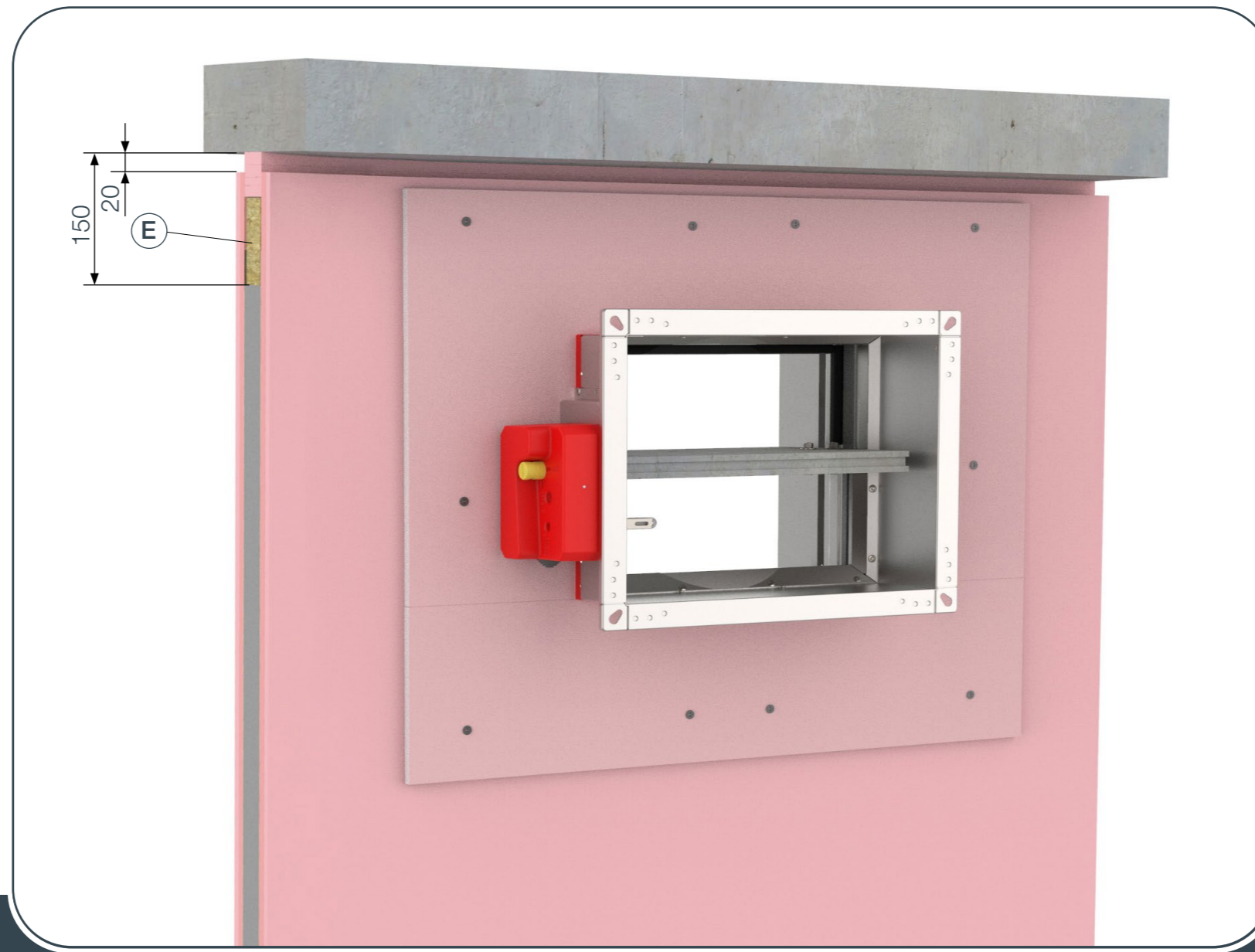

### INSTALLATION



-  [PRODUCT OVERVIEW](#)
-  [DIMENSIONS](#)
-  [INSTALLATIONS](#)
-  [ACTUATORS](#)
-  [ACCESSORIES](#)
-  [REPLACEMENTS](#)
-  [MAINTENANCE AND OPERATION](#)

Possible damper orientations



FIRE DAMPER - FD

**Always ensure the damper is sufficiently supported and a breakaway joint is incorporated between the damper and adjoining ductwork on both sides**

1. Prepare subconstruction and cladding of the wall with gypsum boards acc. to technical drawing. Take care that cladding of the wall is not connected to profile connected to the ceiling so it could compensate movement of the ceiling without impact to the wall." Fill the space between the ceiling segment and the wall with mineral wool. Create an opening in the wall B + 80 mm x H + 80 mm.

2. Insert the fire damper into the opening and fix the mounting bracker with self tapping screw (3,5 x 35 mm)

3. Fill the space between the damper and the wall with gypsum plaster/ mortar.

4. Cover the mineral wool with GKF gypsum boards (12,5 mm thick) and fix them with self-tapping screws Ø3,5x45 mm.

**Damper blade must be closed during installation!**

**Test the operation of the damper blade!**

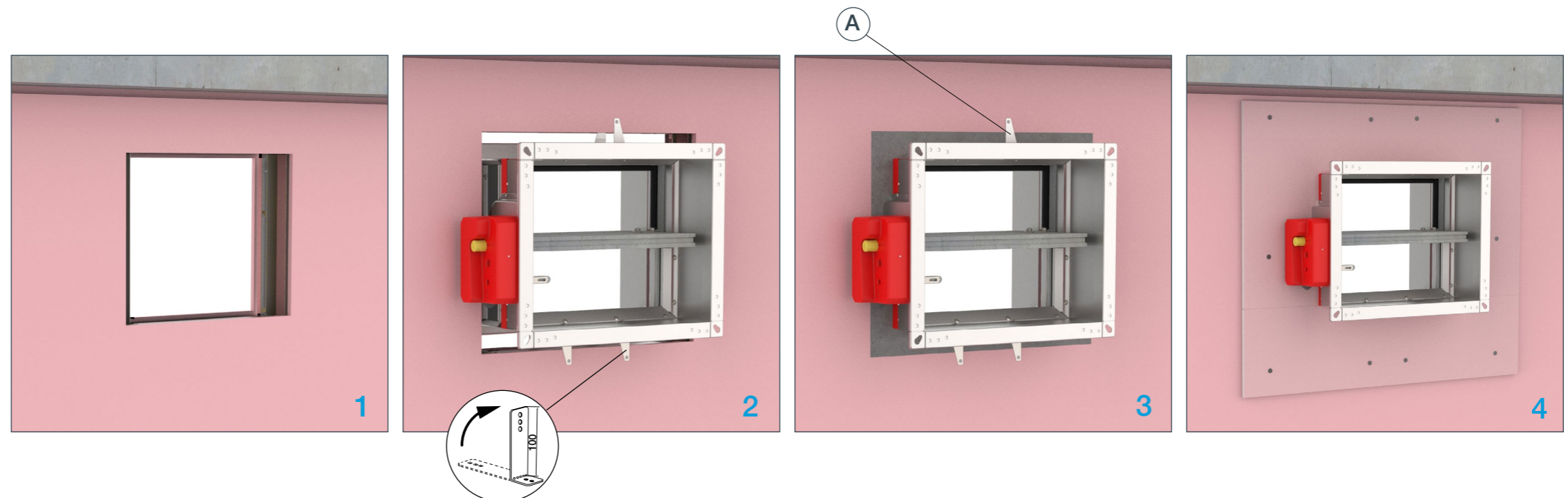

## Rigid floor/ceiling installation (mortar sealing)

The floor/ceiling is composed of concrete blocks (minimum density of 450 kg/m<sup>3</sup>) or reinforced concrete (minimum density of 2200 kg/m<sup>3</sup>) and with a minimum thickness of 100 mm. Installation material: gypsum plaster or mortar (C).



### INSTALLATION

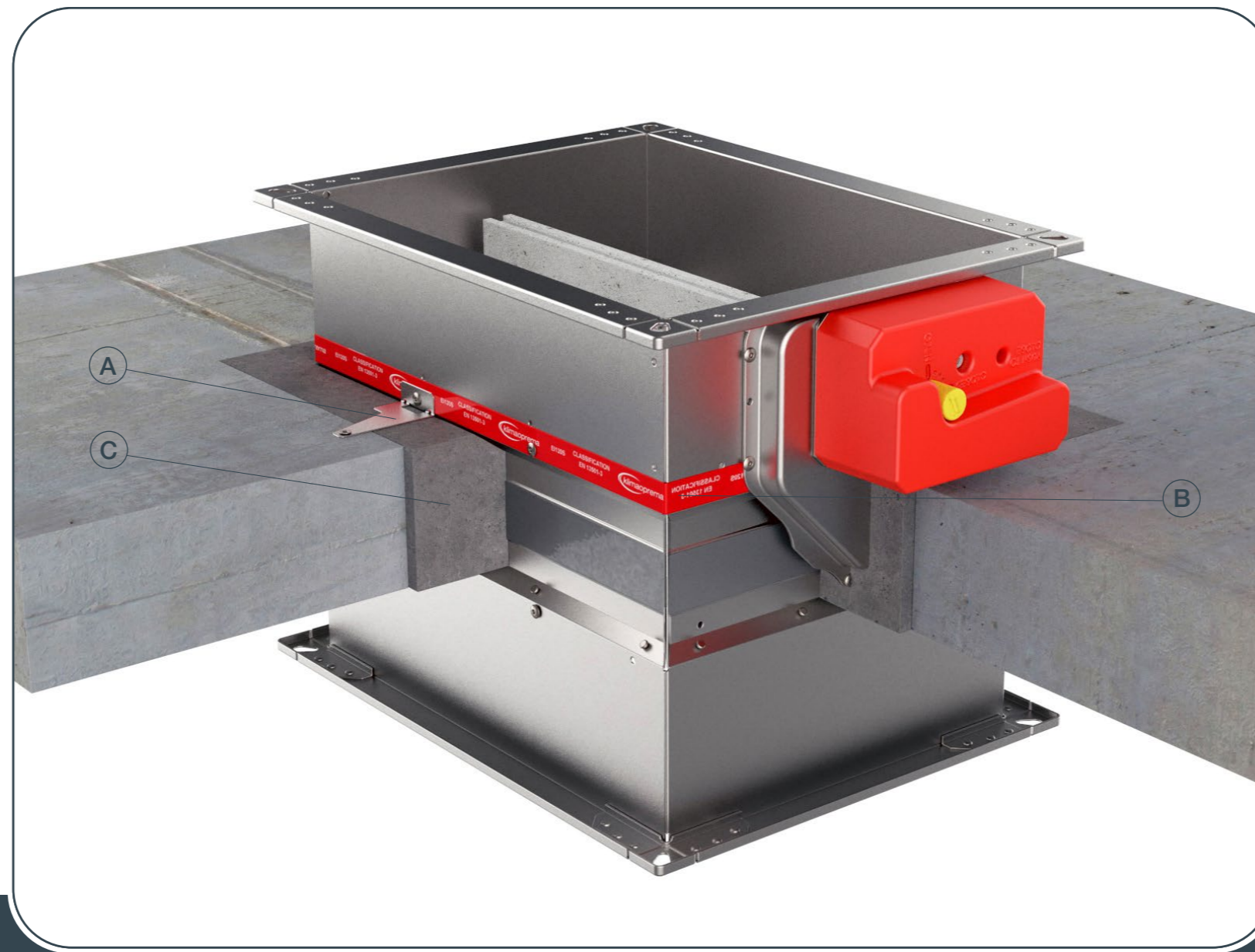

- ▼ [PRODUCT OVERVIEW](#)
- ▼ [DIMENSIONS](#)
- ▼ [INSTALLATIONS](#)
- ▼ [ACTUATORS](#)
- ▼ [ACCESSORIES](#)
- ▼ [REPLACEMENTS](#)
- ▼ [MAINTENANCE AND OPERATION](#)

Possible damper orientations



FIRE DAMPER - FD

**Always ensure the damper is sufficiently supported and a breakaway joint is incorporated between the damper and adjoining ductwork on both sides**

1. Recommended wall opening for the fire damper installation is B (H) + 80 mm or more (up to 50% more). Bend the fixing bracket (A) 90° (bracket screw hole is 6 mm in diameter). Insert fire damper into wall to the wall limit mark (B) on the damper.

**Damper blade must be closed during installation!**

2. Fix the damper to the floor/ceiling using screws.

3/3\*. Fill the space between the damper and the floor/ceiling with mortar (C).

**Test the operation of the damper blade!**

\* Build the support for installation according to the drawing, [see page 53](#).

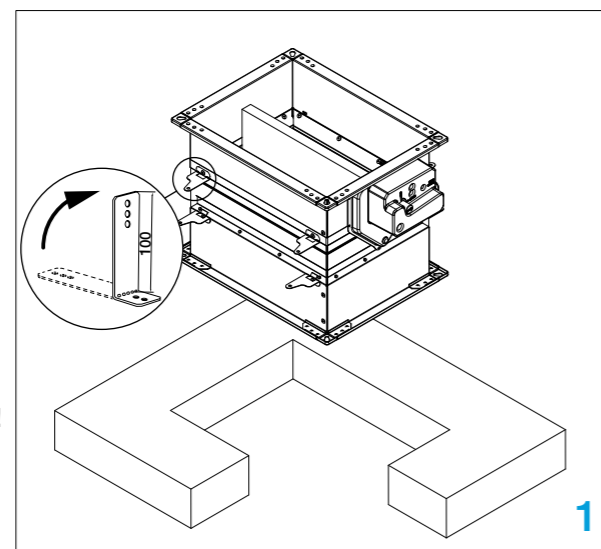

1

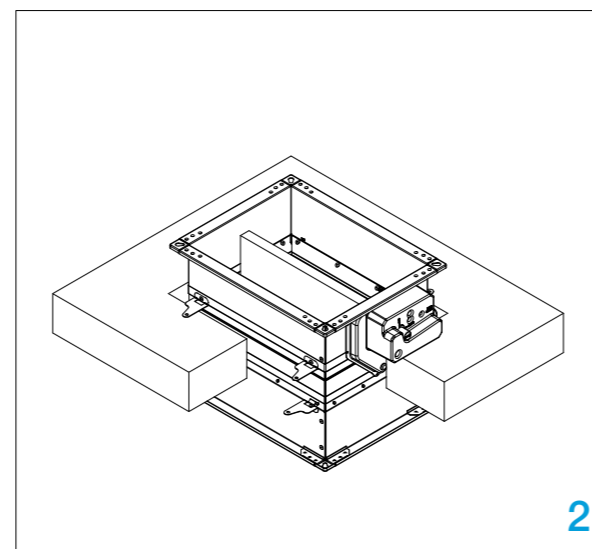

2

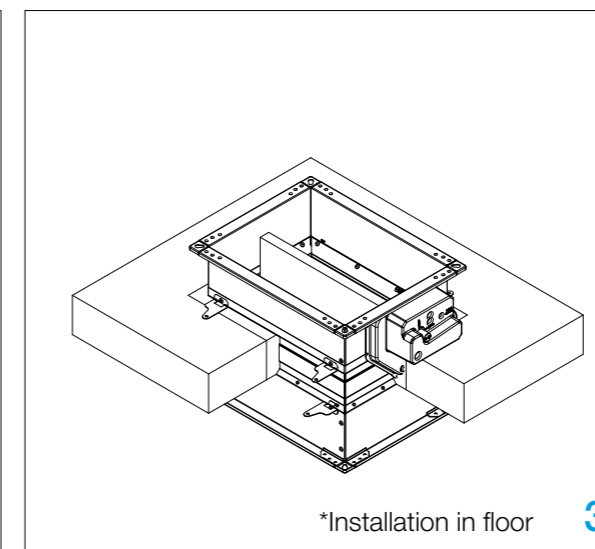

\*Installation in floor 3

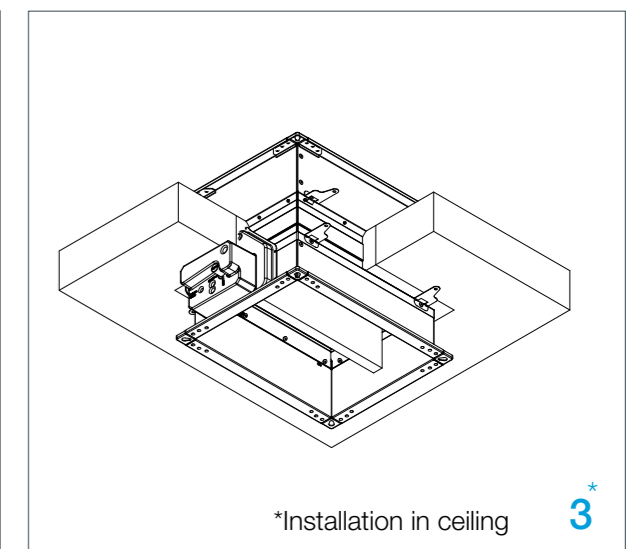

\*Installation in ceiling 3\*

## Rigid floor/ceiling installation (Fire Batt/ Weichschott)

The floor/ceiling is composed of concrete blocks (minimum density of 450 kg/m<sup>3</sup>) or reinforced concrete (minimum density of 2200 kg/m<sup>3</sup>) and with a minimum thickness of 100 mm. Installation material: mineral wool (C) (minimum density of 140 kg/m<sup>3</sup>), fire protection coating (D).



### INSTALLATION

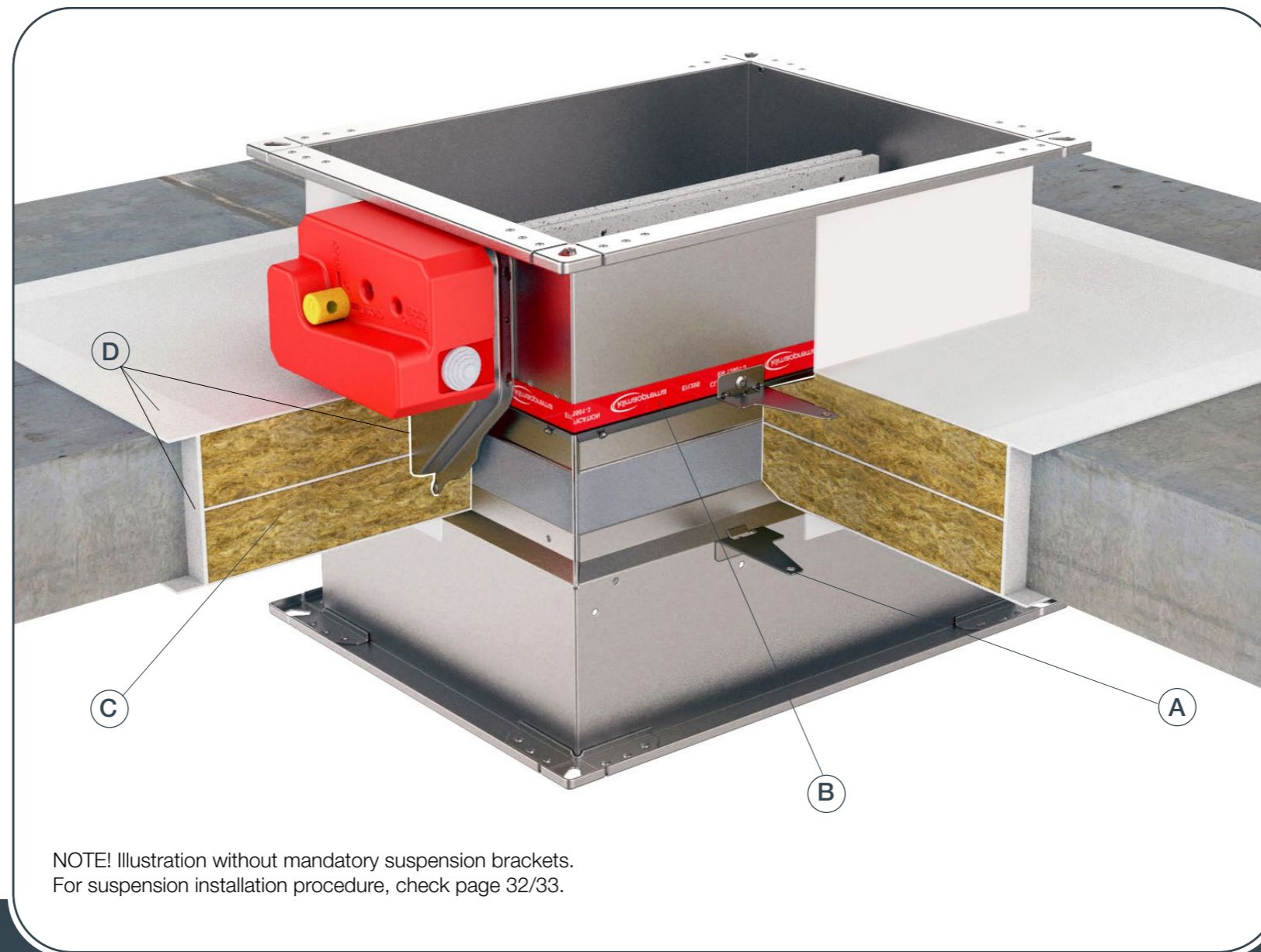

- ▼ PRODUCT OVERVIEW
- ▼ DIMENSIONS
- ▼ INSTALLATIONS
- ▼ ACTUATORS
- ▼ ACCESSORIES
- ▼ REPLACEMENTS
- ▼ MAINTENANCE AND OPERATION

Possible damper orientations



FIRE DAMPER - FD

**Always ensure the damper is sufficiently supported and a breakaway joint is incorporated between the damper and adjoining ductwork on both sides**

1. Recommended floor/ceiling opening for fire damper installation is B(H)+ 300 mm, but openings from B(H)+ 80...450 mm can also be used.

**Damper blade must be closed during installation!**

2. Bend the fixing bracket (A) 90° (bracket screw hole is 6 mm in diameter). Insert fire damper into wall to the wall limit mark (B) on the damper. Fill the space between casing and ceiling with two layers of mineral wool (C) (50 mm thick, coated on one side).

3/3\*. Connections of mineral wool should be sealed with intumescent fire resistant sealant (D). Mineral wool and damper casing must be coated with 2 mm thick fire protection coating. Damper casing should be coated up to profile flanges.

\*Fire Batt floor/ceiling installations require a suspension for the fire damper. For more details, see [page 35 rigid floor /](#) [page 36 ceiling](#).

**Test the operation of the damper blade!**

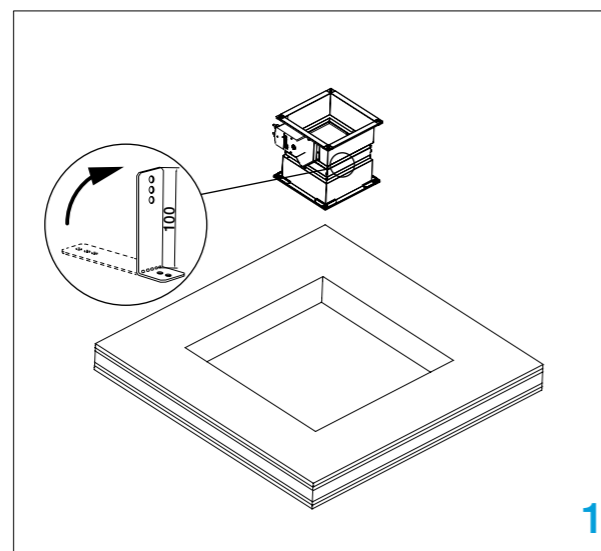

1

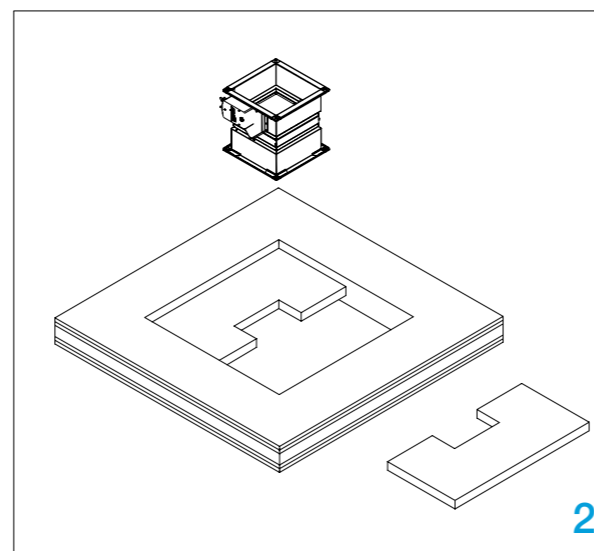

2

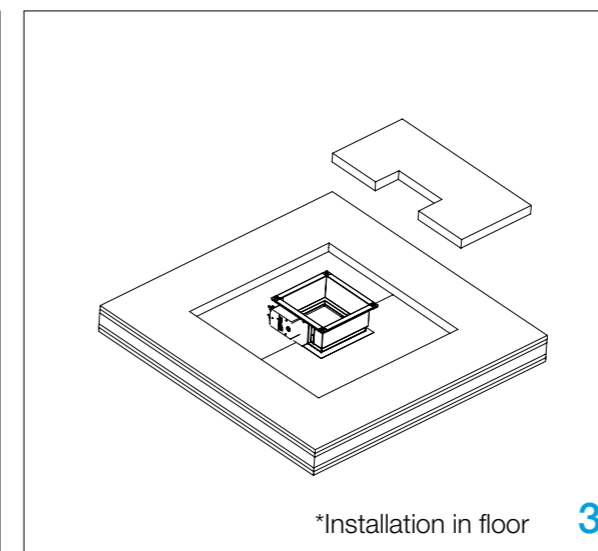

\*Installation in floor 3

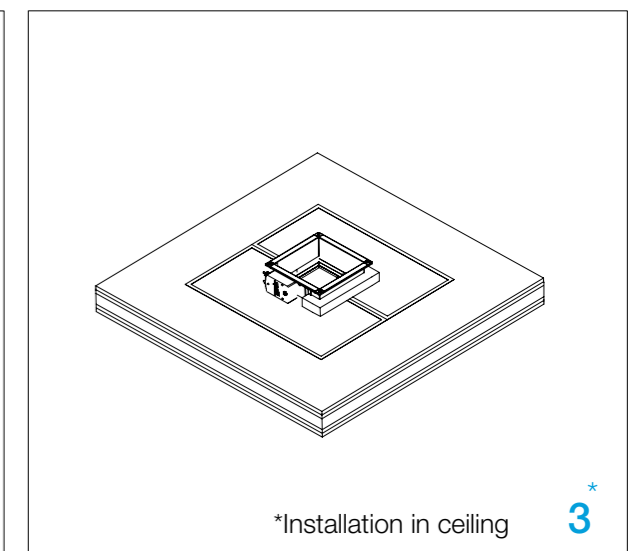

\*Installation in ceiling 3\*

## Suspension for mortarless floor installation

Suspension systems are required for the Fire Batt/Weichschott installation of the fire damper with mineral wool in floor slabs. Fire dampers can be suspended from solid floor slabs using adequately sized threaded rods. Load the suspension system only with the weight of the fire damper. Ducts must be suspended separately.



### INSTALLATION

1. Suspension strut should be connected with drop rods (8/10 mm) to the floor. It is used to support the damper and ease the installation.
2. Support steel C profiles by 90 mm high piece of aerated concrete or similar rigid material.
3. Suspend the fire damper to the steel C profiles. Close the space between casing and floor with Firestop board (Firebatt) 2x50 mm (minimum density of 140 kg/m<sup>3</sup>) and coat the casing.

**Damper blade must be closed during installation!**

**Test the operation of the damper blade!**

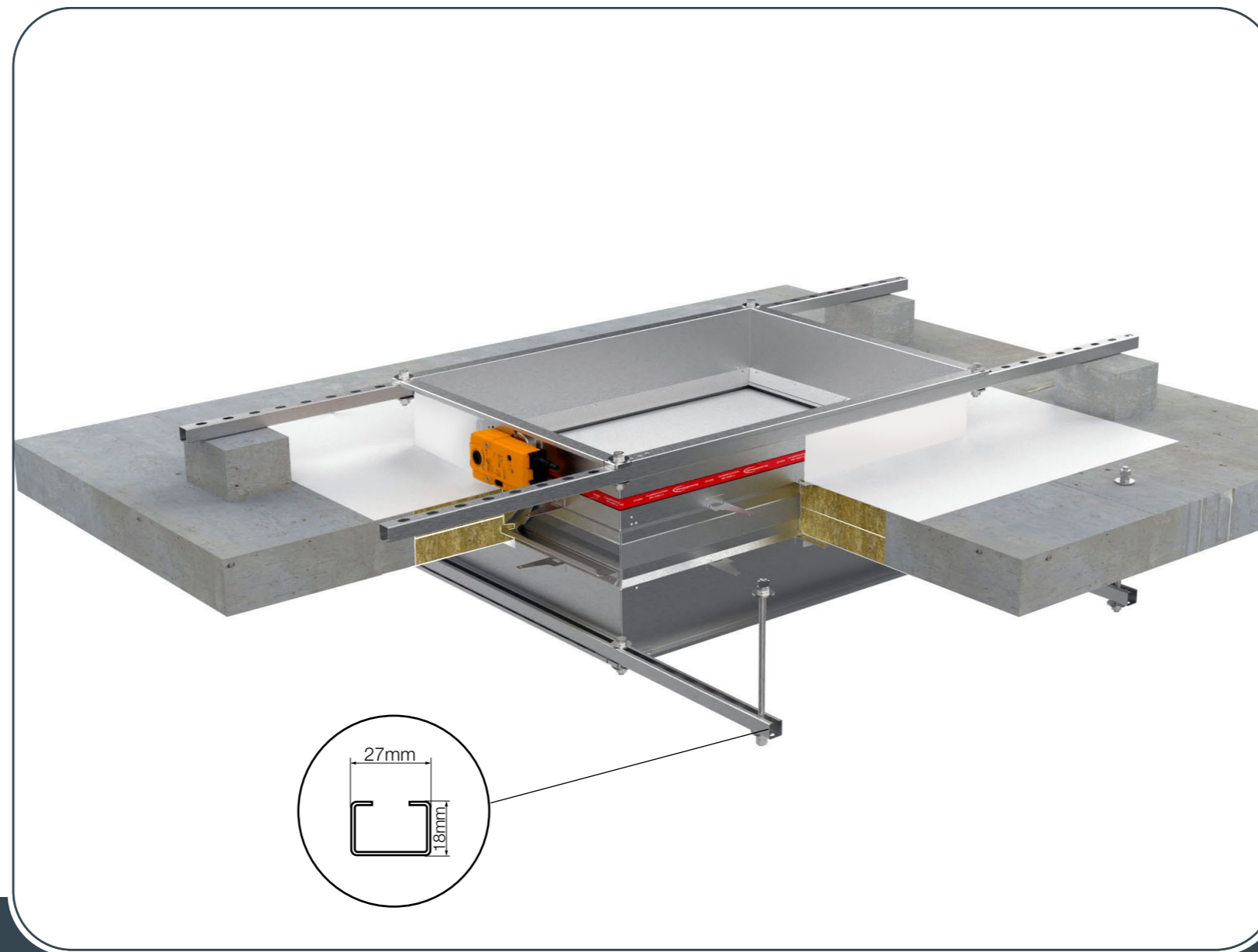

- ▼ [PRODUCT OVERVIEW](#)
- ▼ [DIMENSIONS](#)
- ▼ [INSTALLATIONS](#)
- ▼ [ACTUATORS](#)
- ▼ [ACCESSORIES](#)
- ▼ [REPLACEMENTS](#)
- ▼ [MAINTENANCE AND OPERATION](#)

Possible damper orientations



FIRE DAMPER - FD

**Always ensure the damper is sufficiently supported and a breakaway joint is incorporated between the damper and adjoining ductwork on both sides**

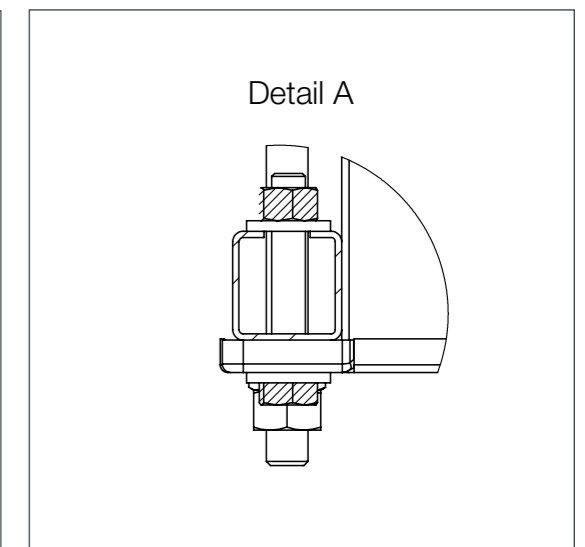
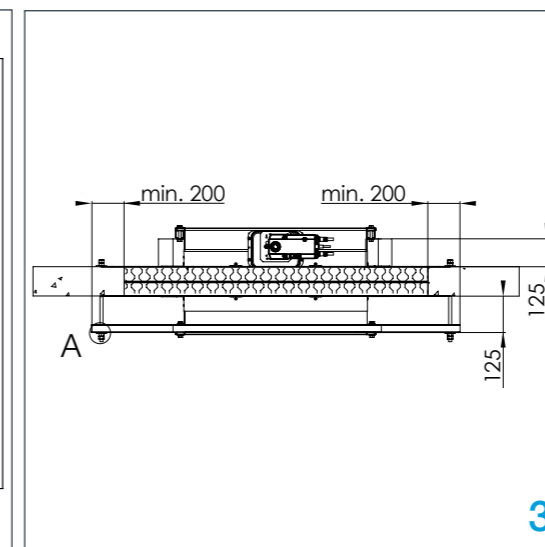
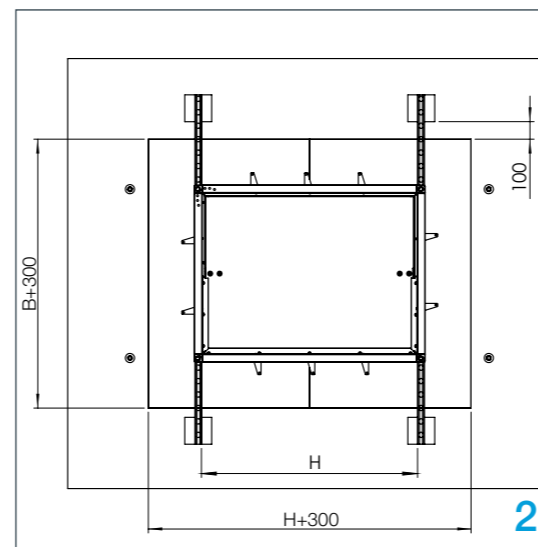
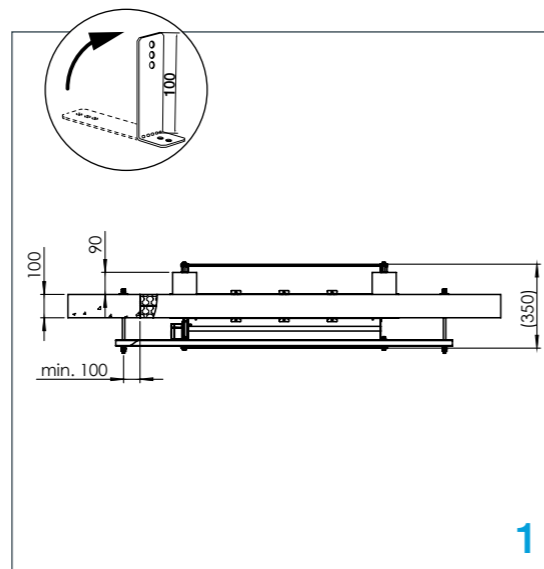

## Suspension for mortarless ceiling installation

Suspension systems are required for the Fire Batt/Weichschott installation of the fire damper with mineral wool in floor ceiling slabs. Fire dampers can be suspended from solid ceiling slabs using adequately sized threaded rods. Load the suspension system only with the weight of the fire damper. Ducts must be suspended separately.



### INSTALLATION

1. Suspension strut should be connected with drop rods (8/10 mm) to the ceiling slab above. It is used to support the damper and ease the installation.
2. Support steel C profiles by 90 mm high piece of aerated concrete or similar rigid material.
3. Suspend the fire damper to the steel C profiles. Close the space between casing and floor/ceiling with Firestop board (Firebatt) 2x50 mm (minimum density of 140 kg/m<sup>3</sup>) and coat the casing.

**Damper blade must be closed during installation!**

**Test the operation of the damper blade!**

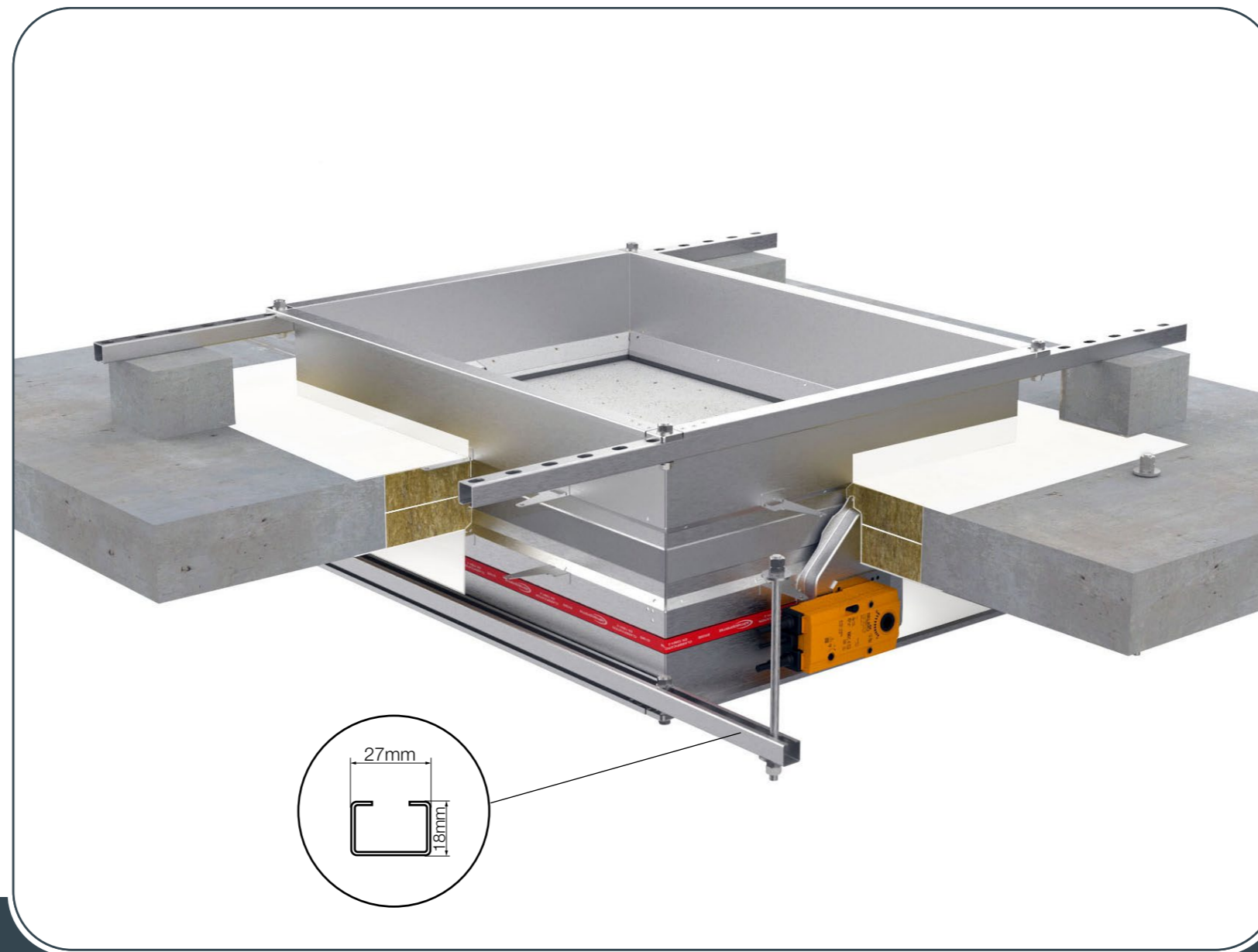

- ▼ [PRODUCT OVERVIEW](#)
- ▼ [DIMENSIONS](#)
- ▼ [INSTALLATIONS](#)
- ▼ [ACTUATORS](#)
- ▼ [ACCESSORIES](#)
- ▼ [REPLACEMENTS](#)
- ▼ [MAINTENANCE AND OPERATION](#)

Possible damper orientations



FIRE DAMPER - FD

**Always ensure the damper is sufficiently supported and a breakaway joint is incorporated between the damper and adjoining ductwork on both sides**

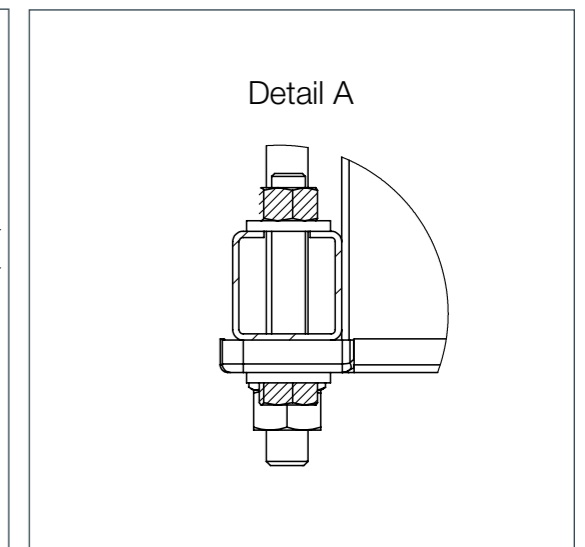
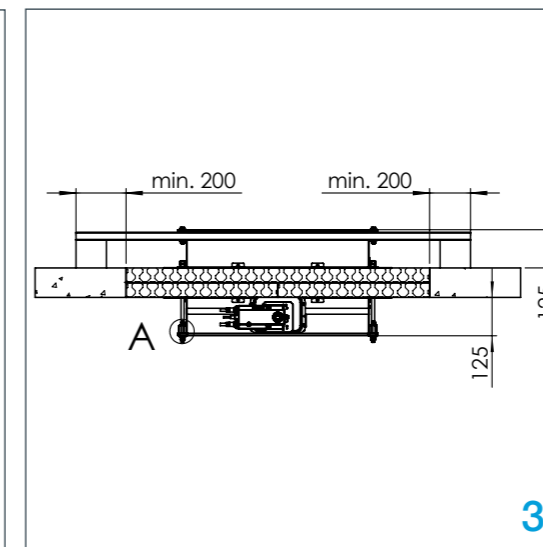
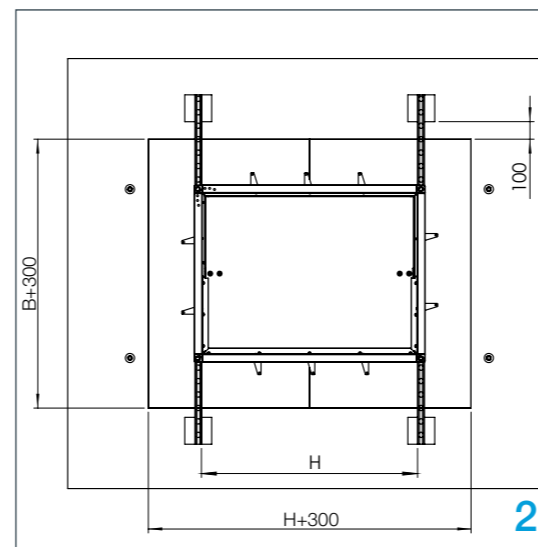
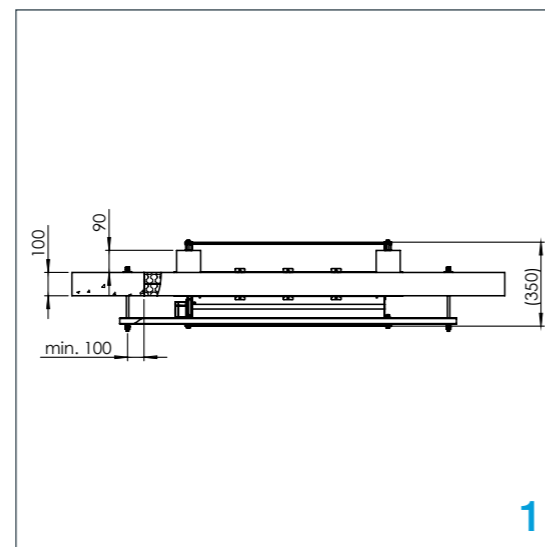

## Suspension for mortarless installation close to ceiling

Suspension systems are required for the dry mortarless installation of the fire damper with mineral wool in solid walls and flexible walls. Fire dampers can be suspended from solid ceiling slabs using adequately sized threaded rods. Load the suspension system only with the weight of the fire damper. Ducts must be suspended separately.

**Refers to dampers that are installed less than 80 mm to the ceiling!**



### INSTALLATION



- ▼ [PRODUCT OVERVIEW](#)
- ▼ [DIMENSIONS](#)
- ▼ [INSTALLATIONS](#)
- ▼ [ACTUATORS](#)
- ▼ [ACCESSORIES](#)
- ▼ [REPLACEMENTS](#)
- ▼ [MAINTENANCE AND OPERATION](#)

Possible damper orientations



FIRE DAMPER - FD

**Always ensure the damper is sufficiently supported and a breakaway joint is incorporated between the damper and adjoining ductwork on both sides**

1. Create an opening. The opening must be large enough to install the seal! (min.80 mm) Install threaded rods (8 mm) to the ceiling above.

**WARNING!**

Provide enough space for servicing and testing the actuator!

2. Bend the fixing bracket **(A)** 90° (bracket screw hole is 6 mm in diameter). Insert fire damper into wall to the wall limit mark **(B)** on the damper. Fix the C profile on the drop rods using M8 screws.

**Damper blade must be closed during installation!**

3. Close the space between casing and wall with mineral wool **(C)** (minimum density of 140 kg/m<sup>3</sup>). Connections of mineral wool should be sealed with intumescent fire resistant sealant **(D)**. Mineral wool and damper casing must be coated with 2 mm.

**Test the operation of the damper blade!**

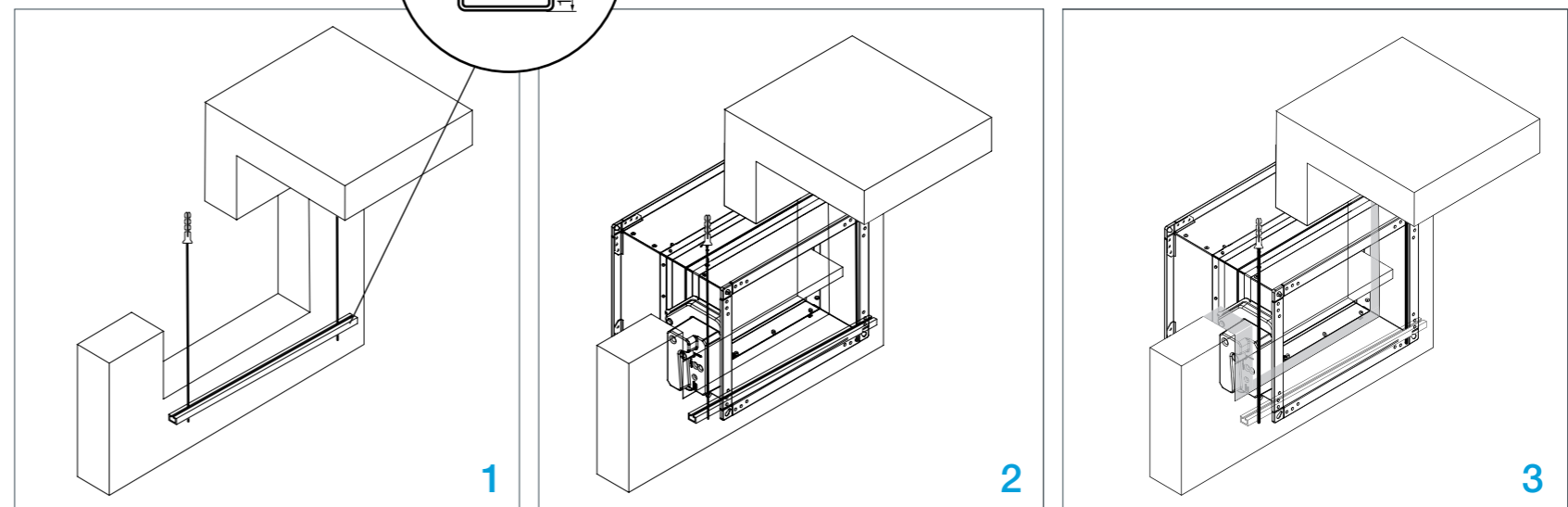
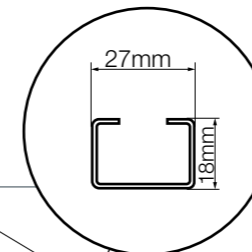

## Rigid wall installation Applique installation frame

The wall is composed of concrete blocks (minimum density of 450 kg/m<sup>3</sup>) or reinforced concrete (minimum density of 2200 kg/m<sup>3</sup>) and with a minimum thickness of 100 mm.

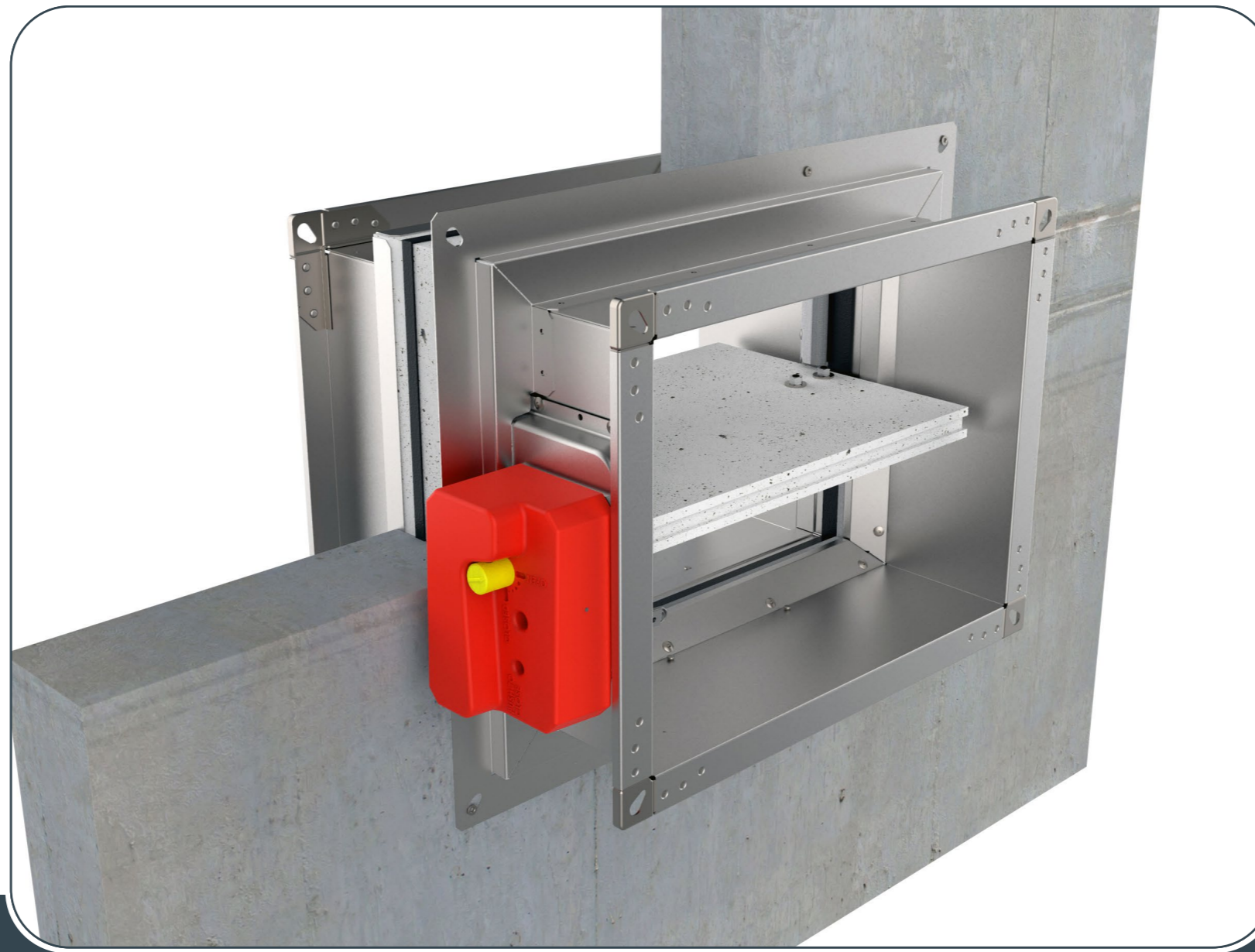

- ▼ [PRODUCT OVERVIEW](#)
- ▼ [DIMENSIONS](#)
- ▼ [INSTALLATIONS](#)
- ▼ [ACTUATORS](#)
- ▼ [ACCESSORIES](#)
- ▼ [REPLACEMENTS](#)
- ▼ [MAINTENANCE AND OPERATION](#)

Possible damper orientations



FIRE DAMPER - FD

**Always ensure the damper is sufficiently supported and a breakaway joint is incorporated between the damper and adjoining ductwork on both sides**

1. Recommended wall opening for the fire damper installation is B (H) + 80 mm.

**Damper blade must be closed during installation!**

2. Insert fire damper into wall and fasten with screws (4 pcs, 4,8x60 mm).

**Test the operation of the damper blade!**

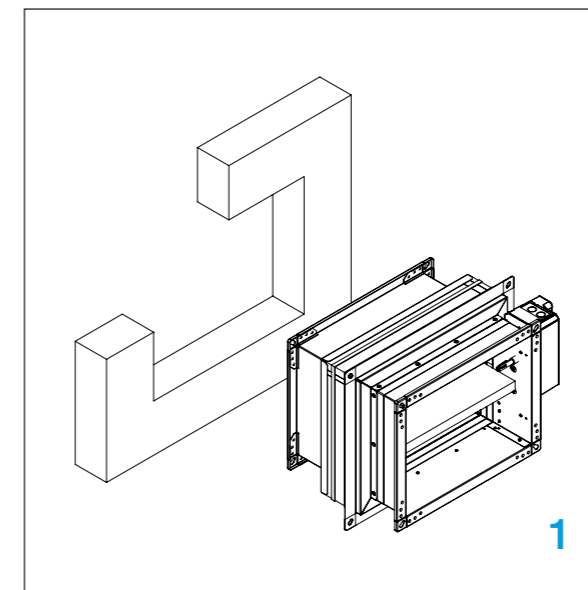

1

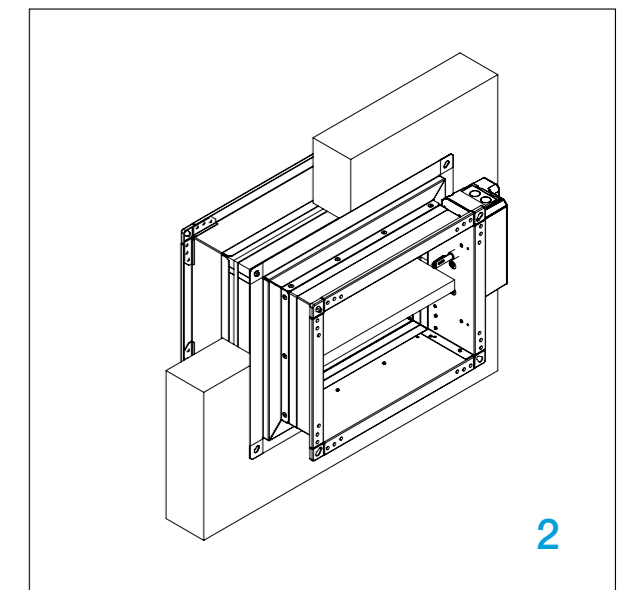

2

## Gypsum blocks wall installation Applique installation frame

The wall is composed of gypsum blocks (minimum density of 995 kg/m<sup>3</sup>), and with minimum thickness of 70 mm.

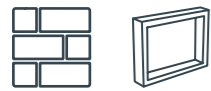

### INSTALLATION

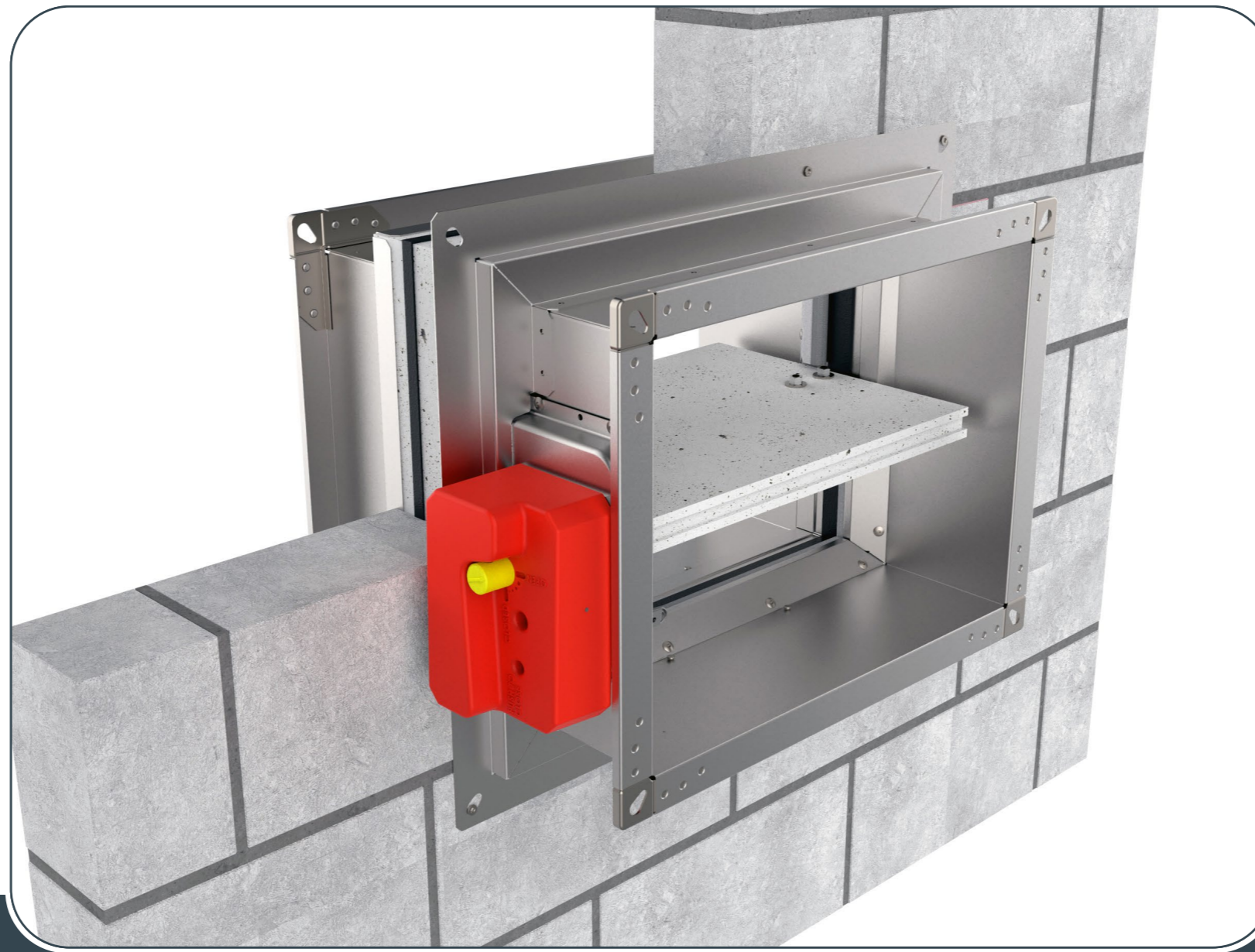

- ▼ [PRODUCT OVERVIEW](#)
- ▼ [DIMENSIONS](#)
- ▼ [INSTALLATIONS](#)
- ▼ [ACTUATORS](#)
- ▼ [ACCESSORIES](#)
- ▼ [REPLACEMENTS](#)
- ▼ [MAINTENANCE AND OPERATION](#)

Possible damper orientations



FIRE DAMPER - FD

**Always ensure the damper is sufficiently supported and a breakaway joint is incorporated between the damper and adjoining ductwork on both sides**

1. Recommended wall opening for the fire damper installation is B (H) + 80 mm.

**Damper blade must be closed during installation!**

2. Insert fire damper into wall and fasten with screws (4 pcs, 4,8x60 mm).

**Test the operation of the damper blade!**

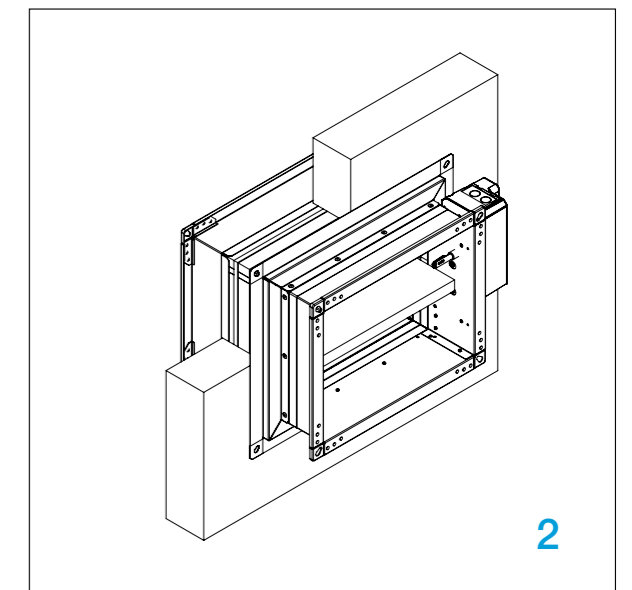
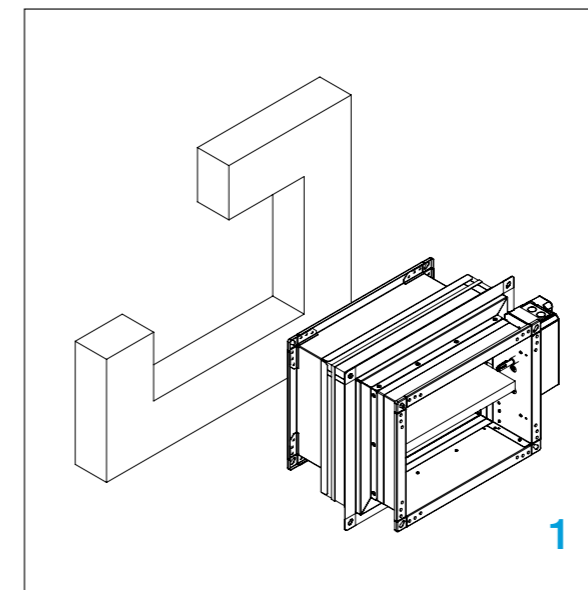

## Flexible wall installation Applique installation frame

The wall is composed of 2x2 plasterboard boards, 12,5 mm thick, installed on a steel frame construction. To fulfill the classification it is **NOT** mandatory to use the mineral wool inside the wall (mineral wool with density up to 100 kg/m<sup>3</sup> can be used). The minimum thickness of the wall is 100 mm.



### INSTALLATION

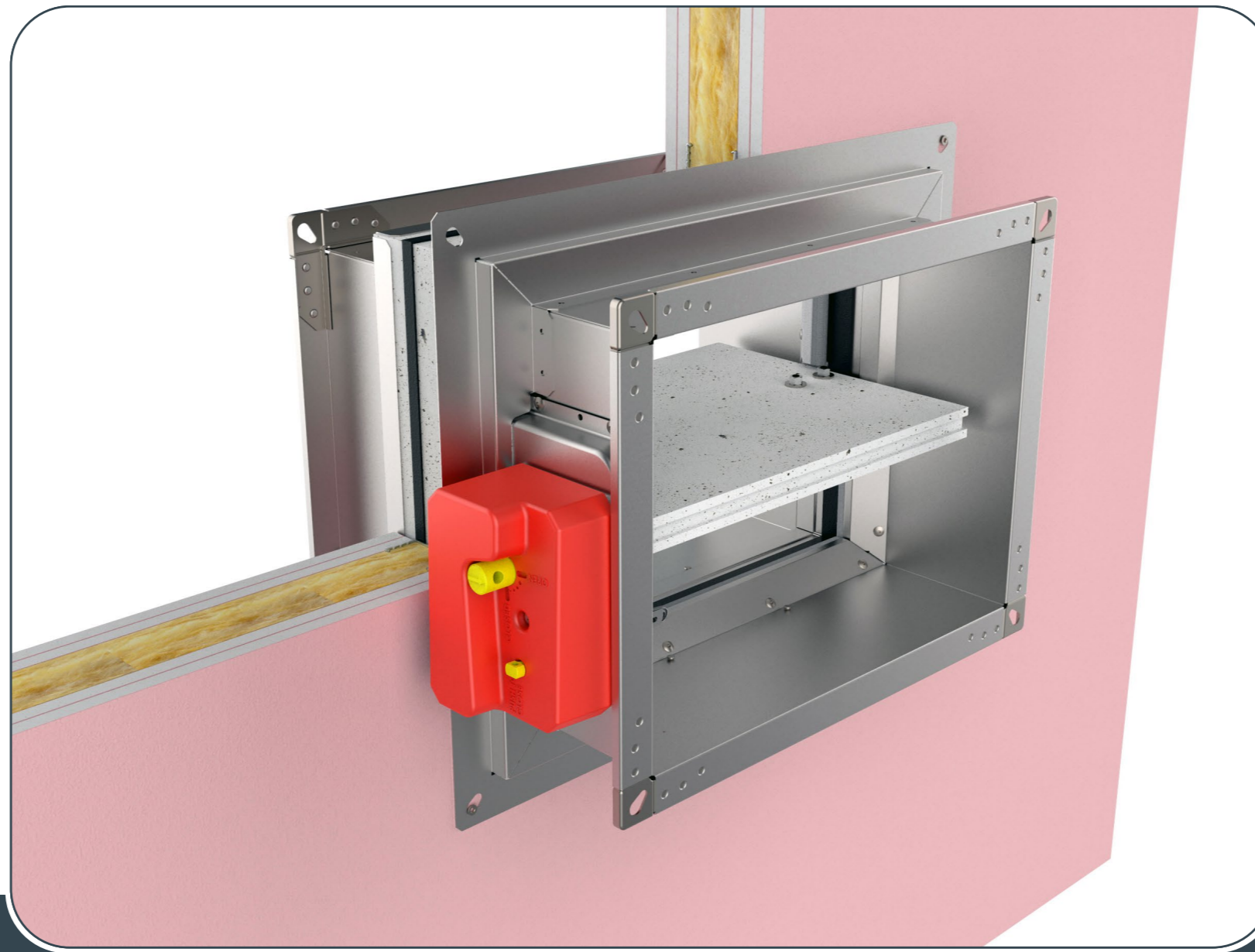

- ▼ [PRODUCT OVERVIEW](#)
- ▼ [DIMENSIONS](#)
- ▼ [INSTALLATIONS](#)
- ▼ [ACTUATORS](#)
- ▼ [ACCESSORIES](#)
- ▼ [REPLACEMENTS](#)
- ▼ [MAINTENANCE AND OPERATION](#)

Possible damper orientations



FIRE DAMPER - FD

**Always ensure the damper is sufficiently supported and a breakaway joint is incorporated between the damper and adjoining ductwork on both sides**

\*Create an opening according to the dimension of the fire damper and build the subframe according to the drawing, [see page 50](#).

1. Place the fire damper in the opening.

**Damper blade must be closed during installation!**

2. Fasten the fire damper with screws.  
(4 pcs, 4,8x60 mm).

**Test the operation of the damper blade!**

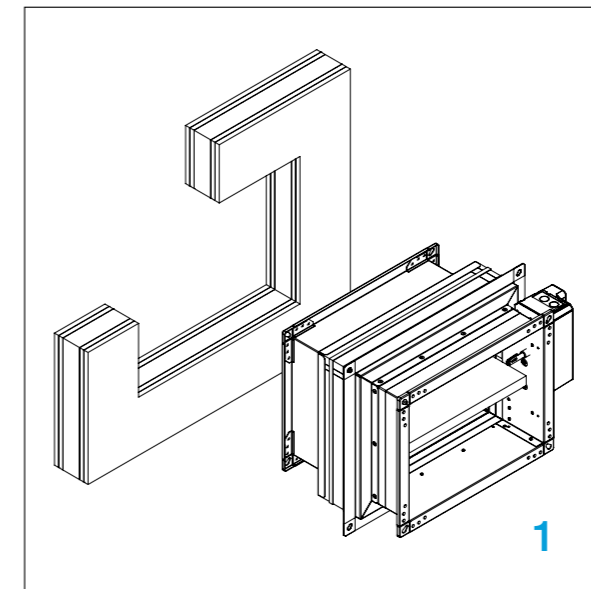

1

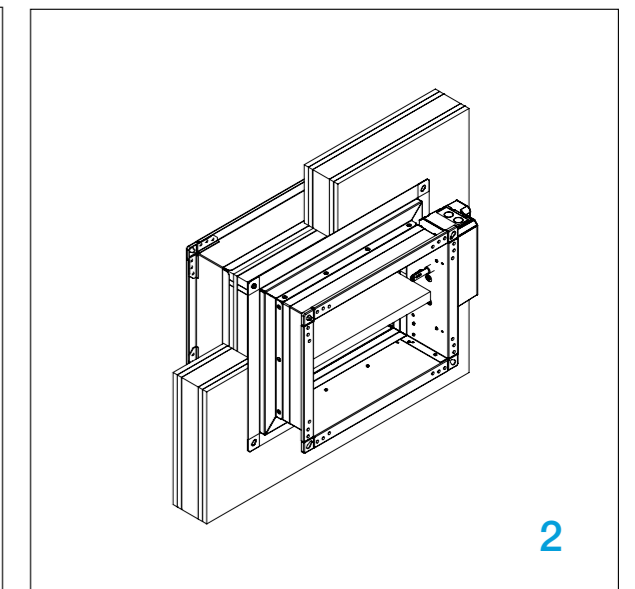

2

## Rigid wall installation MF1/MF2 installation frame

The wall is composed of concrete blocks (minimum density of 450 kg/m<sup>3</sup>) or reinforced concrete (minimum density of 2200 kg/m<sup>3</sup>) and with a minimum thickness of 100 mm.



### INSTALLATION

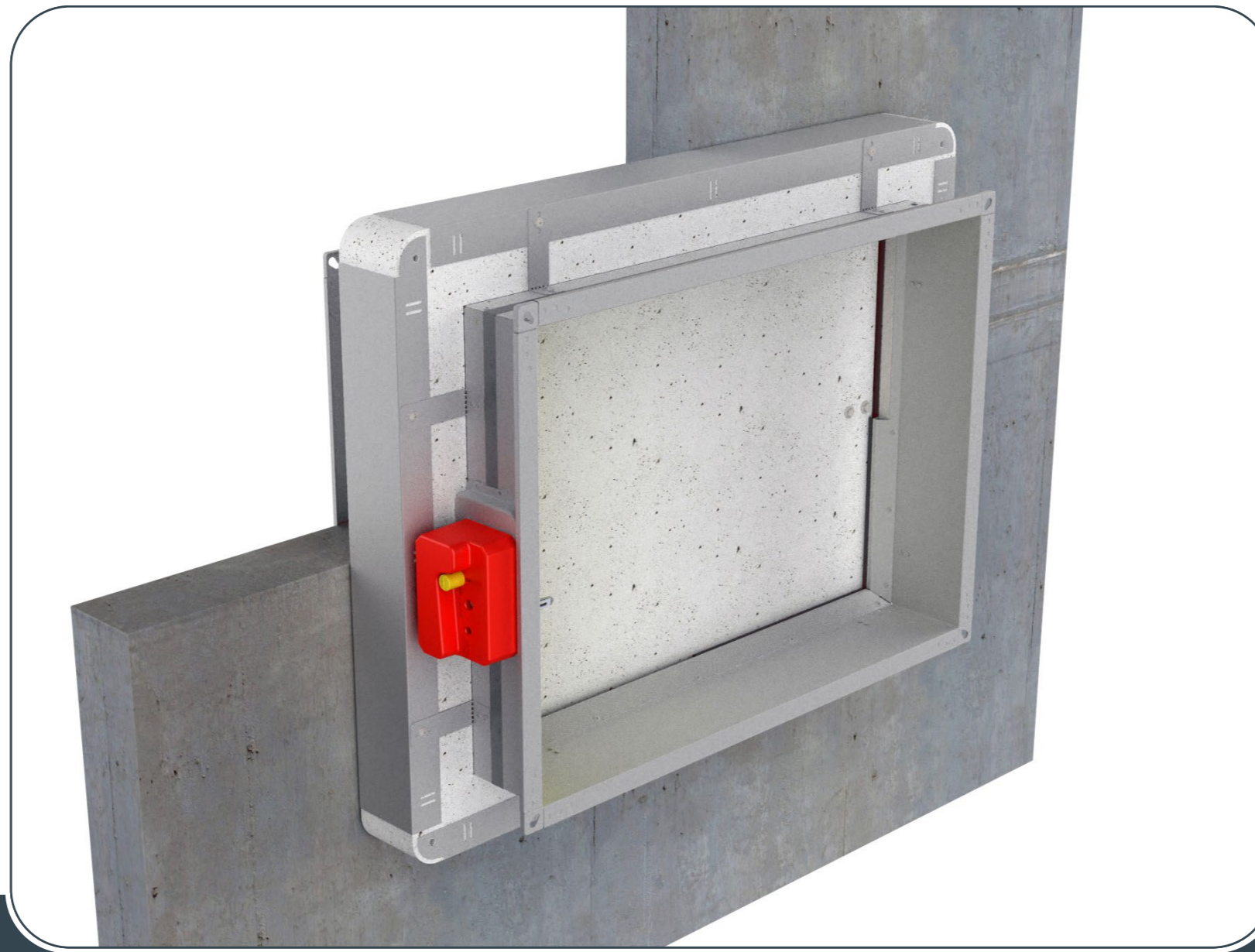

- ▼ [PRODUCT OVERVIEW](#)
- ▼ [DIMENSIONS](#)
- ▼ [INSTALLATIONS](#)
- ▼ [ACTUATORS](#)
- ▼ [ACCESSORIES](#)
- ▼ [REPLACEMENTS](#)
- ▼ [MAINTENANCE AND OPERATION](#)

Possible damper orientations



FIRE DAMPER - FD

**Always ensure the damper is sufficiently supported and a breakaway joint is incorporated between the damper and adjoining ductwork on both sides**

1. Recommended wall opening for the fire damper installation is B (H) + 80 mm.

**Damper blade must be closed during installation!**

2. Insert fire damper into wall and fasten with screws.

FD25 - 4 pcs, 6x140 mm,  
FD40 - 12 pcs, 6x140 mm

**Test the operation of the damper blade!**

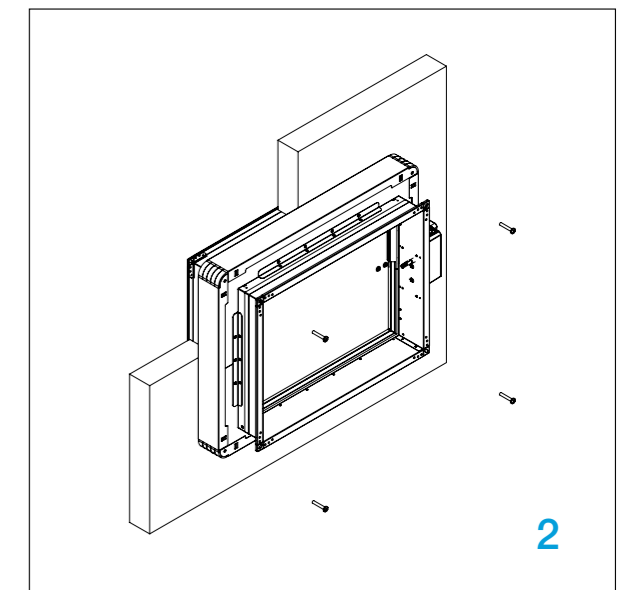
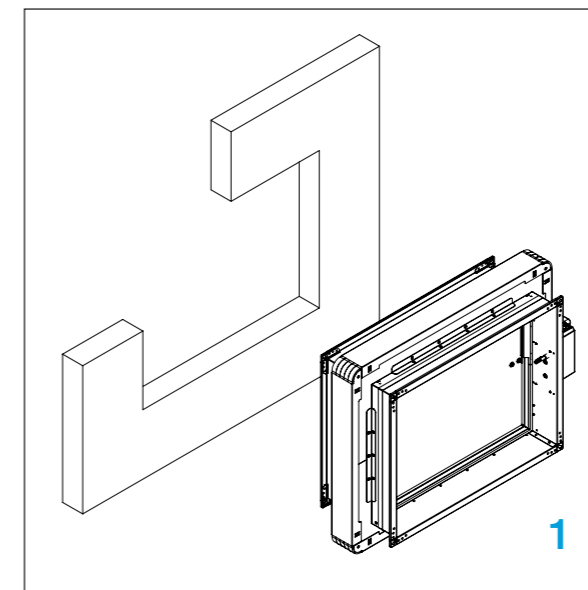

## Gypsum blocks wall installation MF1/MF2 installation frame

The wall is composed of gypsum blocks (minimum density of 995 kg/m<sup>3</sup>), and with minimum thickness of 70 mm.

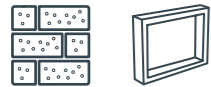

INSTALLATION

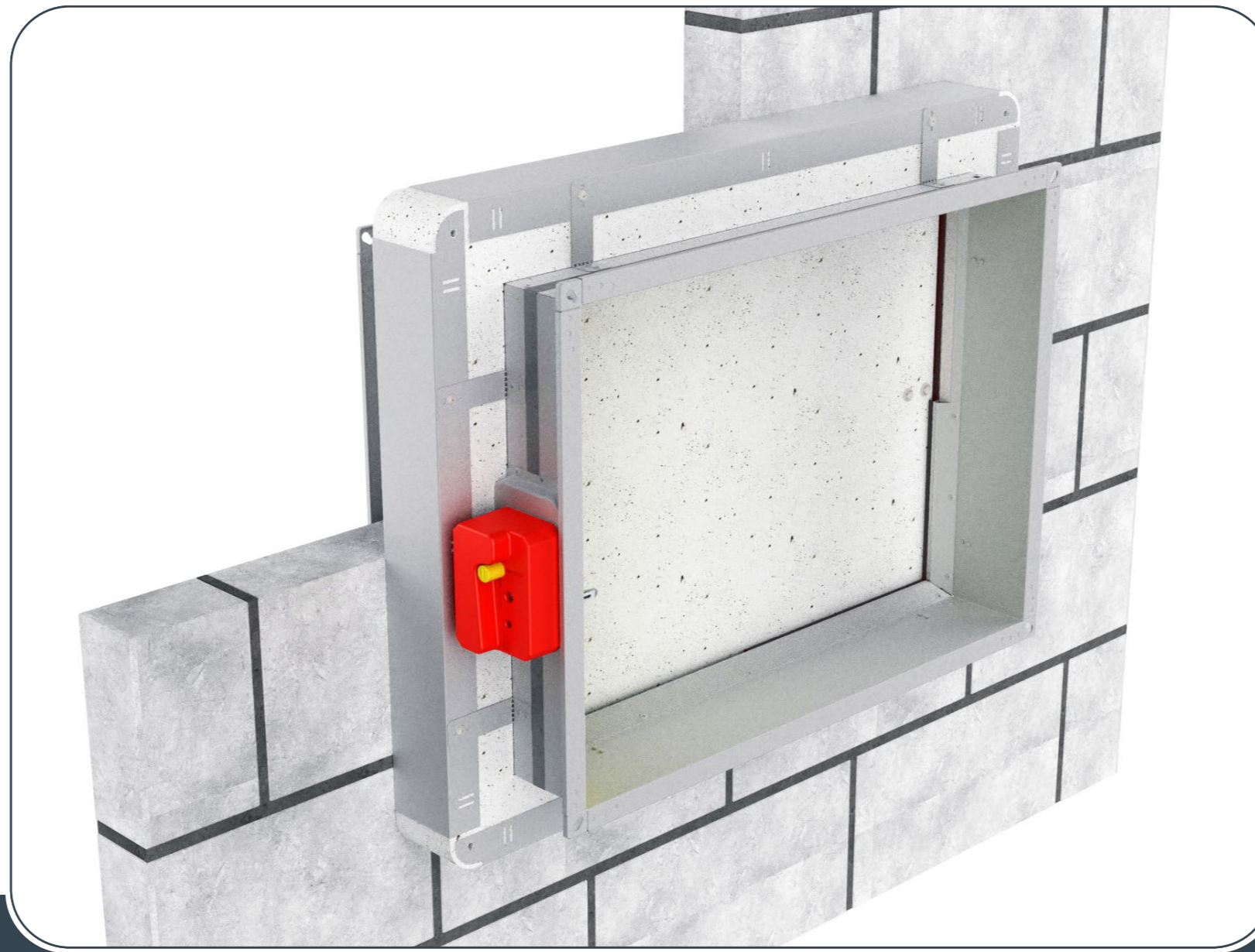

- ▼ [PRODUCT OVERVIEW](#)
- ▼ [DIMENSIONS](#)
- ▼ [INSTALLATIONS](#)
- ▼ [ACTUATORS](#)
- ▼ [ACCESSORIES](#)
- ▼ [REPLACEMENTS](#)
- ▼ [MAINTENANCE AND OPERATION](#)

Possible damper orientations



FIRE DAMPER - FD

**Always ensure the damper is sufficiently supported and a breakaway joint is incorporated between the damper and adjoining ductwork on both sides**

1. Recommended wall opening for the fire damper installation is B (H) + 80 mm.

**Damper blade must be closed during installation!**

2. Insert fire damper into wall and fasten with screws.

FD25 - 4 pcs, 6x140 mm,  
FD40 - 12 pcs, 6x140 mm

**Test the operation of the damper blade!**

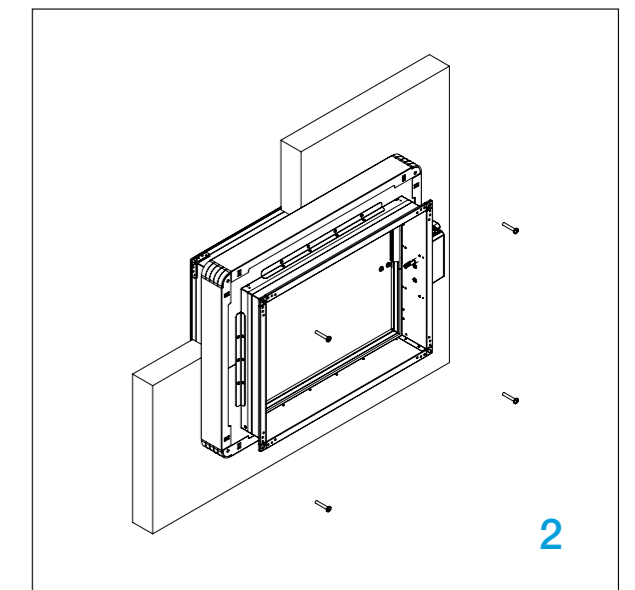
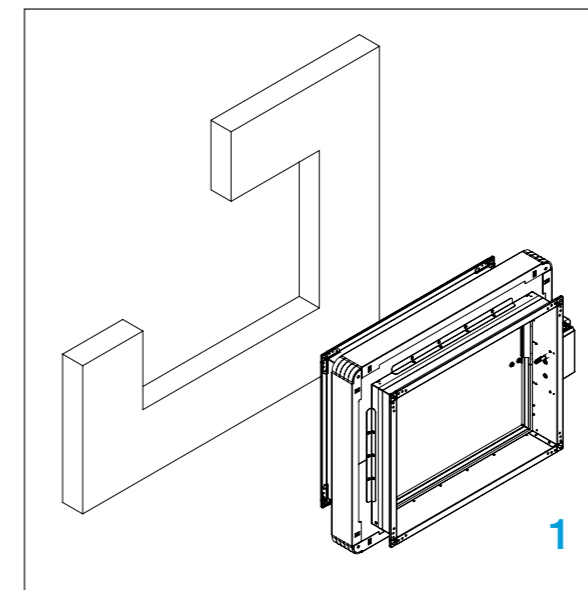

## Flexible wall installation MF1/MF2 installation frame

### MF1 (EI 60 (ve i↔o)S)

The wall is made out of type A (EN520) gypsum plaster boards. To fulfill the classification it is **NOT** mandatory to use the mineral wool inside the wall (mineral wool with density up to 60 kg/m<sup>3</sup> can be used). The minimum thickness of the wall is 100 mm.

### MF2 (EI 90 (ve i↔o)S)

The wall is made out of type F (EN520) gypsum plaster boards, installed on a steel frame construction. To fulfill the classification it is **NOT** mandatory to use the mineral wool inside the wall (mineral wool with density up to 100 kg/m<sup>3</sup> can be used). The minimum thickness of the wall is 100 mm.



INSTALLATION

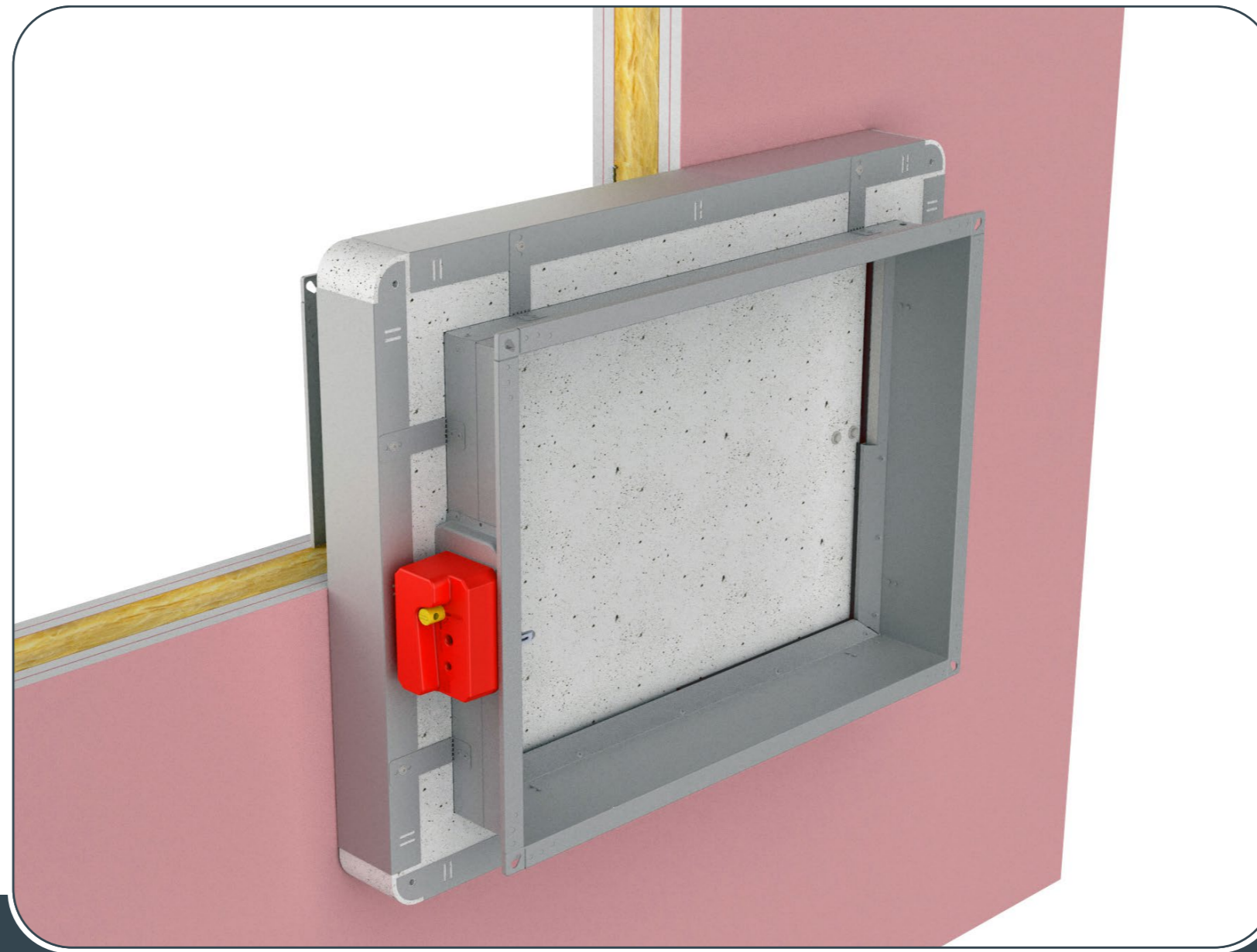

- ▼ [PRODUCT OVERVIEW](#)
- ▼ [DIMENSIONS](#)
- ▼ [INSTALLATIONS](#)
- ▼ [ACTUATORS](#)
- ▼ [ACCESSORIES](#)
- ▼ [REPLACEMENTS](#)
- ▼ [MAINTENANCE AND OPERATION](#)

Possible damper orientations



FIRE DAMPER - FD

**Always ensure the damper is sufficiently supported and a breakaway joint is incorporated between the damper and adjoining ductwork on both sides**

\* Create an opening according to the dimension of the fire damper and build the subframe according to the drawing, [see page 53](#).

1. Place the fire damper in the opening.

**Damper blade must be closed during installation!**

2. Fasten the fire damper with screws.

FD25 - 4 pcs, 6x140 mm,  
FD40 - 12 pcs, 6x140 mm

**Test the operation of the damper blade!**

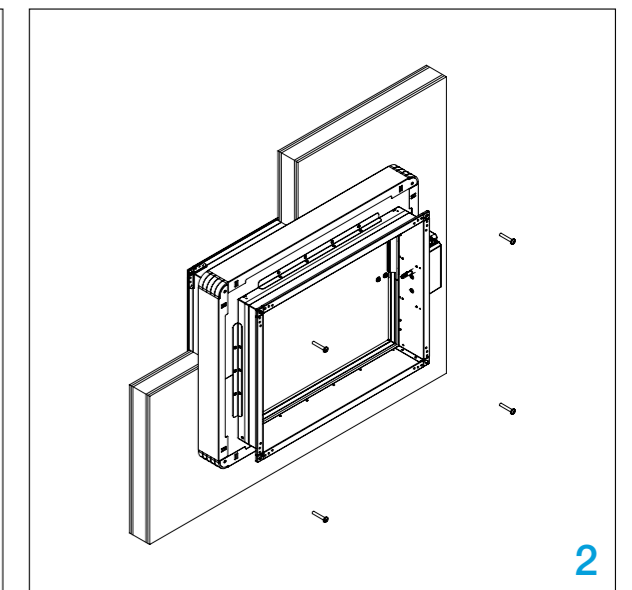
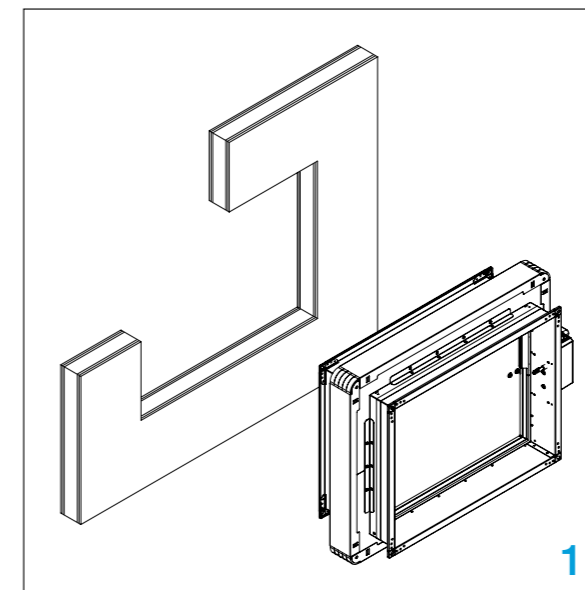

## Rigid floor/ceiling installation MF1/MF2 installation frame

The floor/ceiling is composed of concrete blocks (minimum density of 450 kg/m<sup>3</sup>) or reinforced concrete (minimum density of 2200 kg/m<sup>3</sup>) and with a minimum thickness of 100 mm.



### INSTALLATION

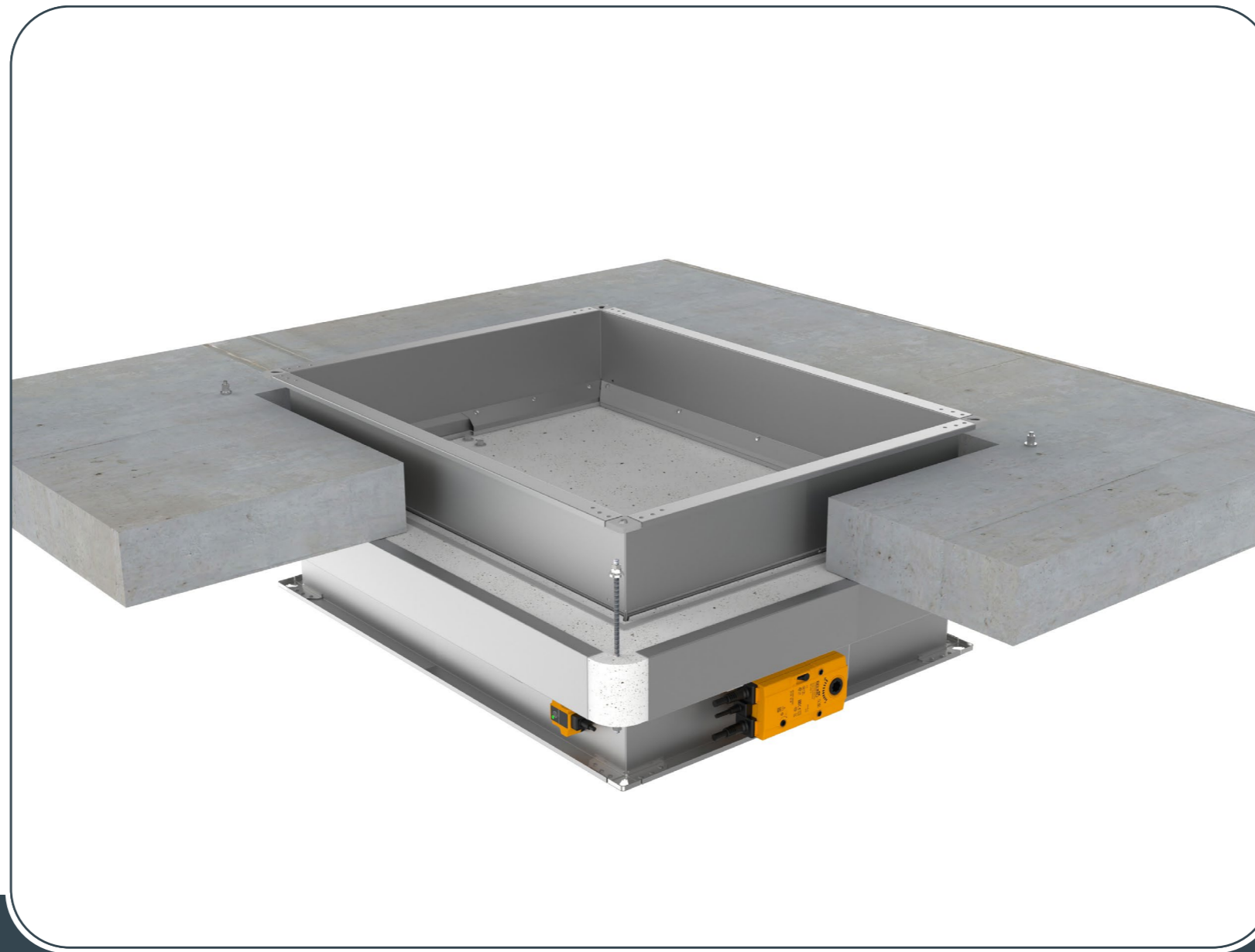

- ▼ [PRODUCT OVERVIEW](#)
- ▼ [DIMENSIONS](#)
- ▼ [INSTALLATIONS](#)
- ▼ [ACTUATORS](#)
- ▼ [ACCESSORIES](#)
- ▼ [REPLACEMENTS](#)
- ▼ [MAINTENANCE AND OPERATION](#)

Possible damper orientations



FIRE DAMPER - FD

**Always ensure the damper is sufficiently supported and a breakaway joint is incorporated between the damper and adjoining ductwork on both sides**

1. Recommended opening for the fire damper installation is  $B(H) + 80$  mm. Insert the fire damper into the opening and mark the places for drilling holes.

2. Remove the fire damper and drill the marked places (8 mm).

3. Mount 4/12 sets of pre-cut threaded rods, washer, nut and conternut on one side. Place pre-assembled threaded rods in holes in floor/ceiling, and place the damper in the opening. Tighten the tightening sets from opposite side with washer, nut and conternut.

**Damper blade must be closed during installation!**

**Test the operation of the damper blade!**

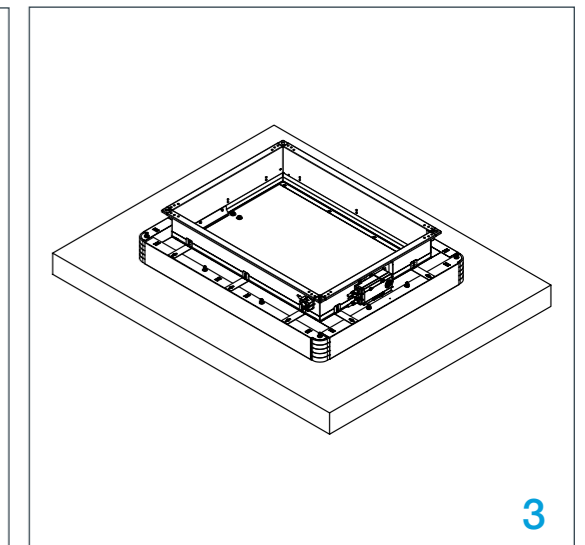
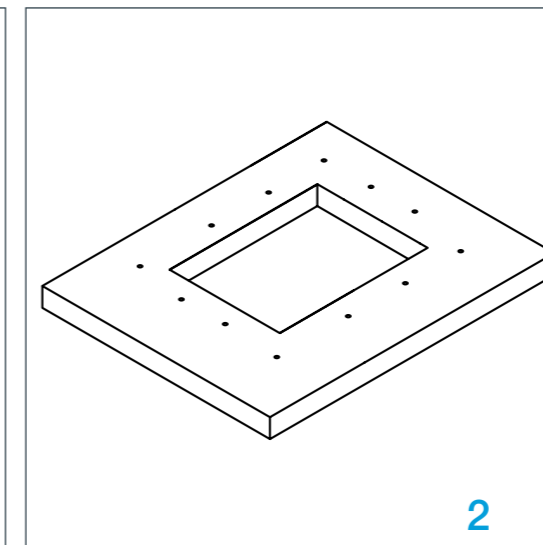
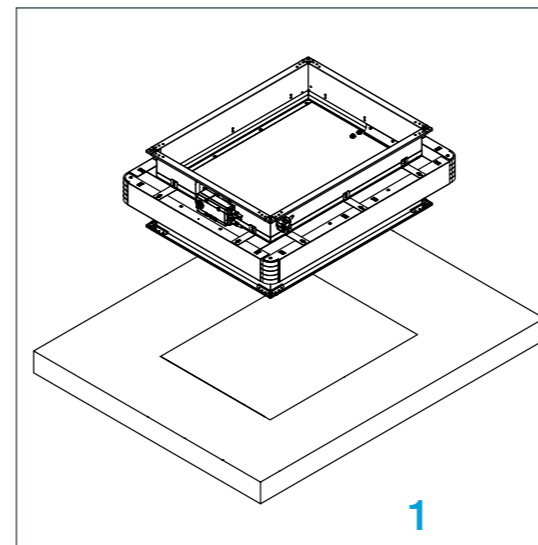

# Shaft wall installation MF2 installation frame

The wall is composed of 1x2 plasterboard boards, 12,5 / 20 mm thick, installed on a steel frame construction.

FD25/FD40 MF2 (EI 60 (ve i↔o)S) - 12,5 mm - GKF/ Piano  
FD25/FD40 MF2 (EI 90 (ve i↔o)S) - 20 mm - Fireboard

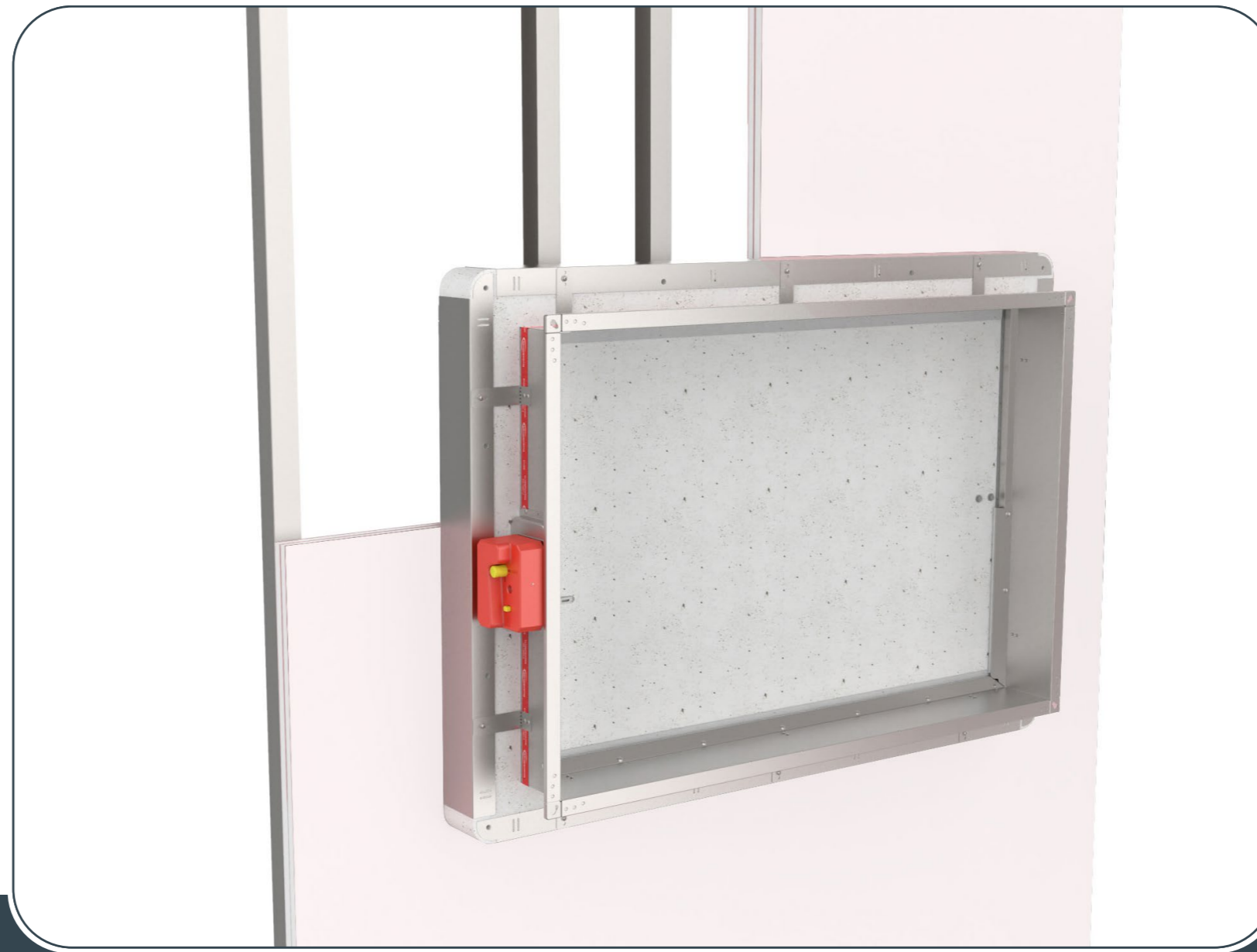

- ▼ [PRODUCT OVERVIEW](#)
- ▼ [DIMENSIONS](#)
- ▼ [INSTALLATIONS](#)
- ▼ [ACTUATORS](#)
- ▼ [ACCESSORIES](#)
- ▼ [REPLACEMENTS](#)
- ▼ [MAINTENANCE AND OPERATION](#)

Possible damper orientations



## INSTALLATION

FIRE DAMPER - FD

**Always ensure the damper is sufficiently supported and a breakaway joint is incorporated between the damper and adjoining ductwork on both sides**

FD-MF2 Fire damper (**B < 625 mm**) installation in 75/90 mm shaft wall with metal studs

FD-MF2 Fire damper (**B > 625 mm**) installation in 75/90 mm shaft wall with metal studs

FD-MF2 Fire damper installation in 90 mm Shaft wall without metal studs (**< 2000 mm**)

1. For fire dampers **B < 625 mm**, make a steel subframe according to drawing (1). For fire dampers **B > 625 mm**, make a steel subframe according to drawing (2). For installation in shaft walls without metal studs, make a steel subframe according to drawing (3).

**Damper blade must be closed during installation!**

2. Place the fire damper in the opening.
3. Insert fire damper into wall and fasten with screws (12 pcs, 6x160 mm).

**Test the operation of the damper blade!**

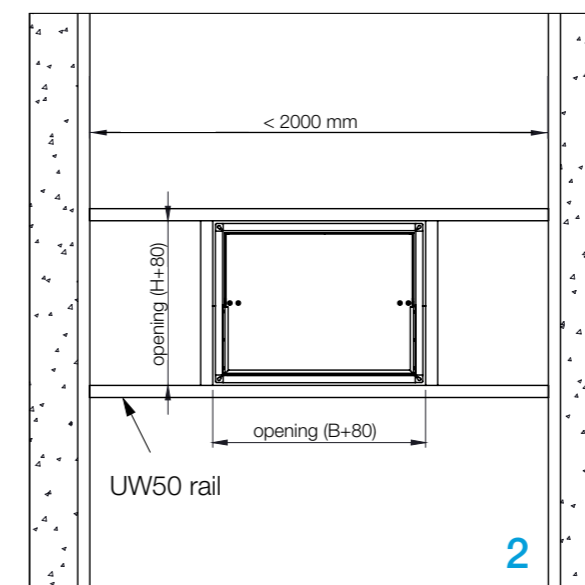
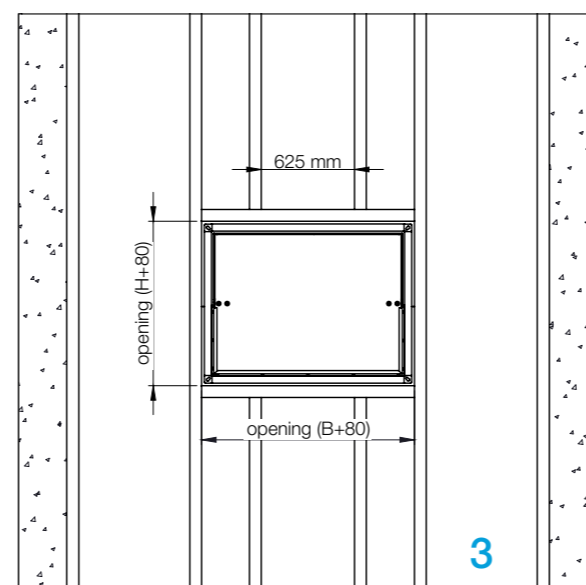
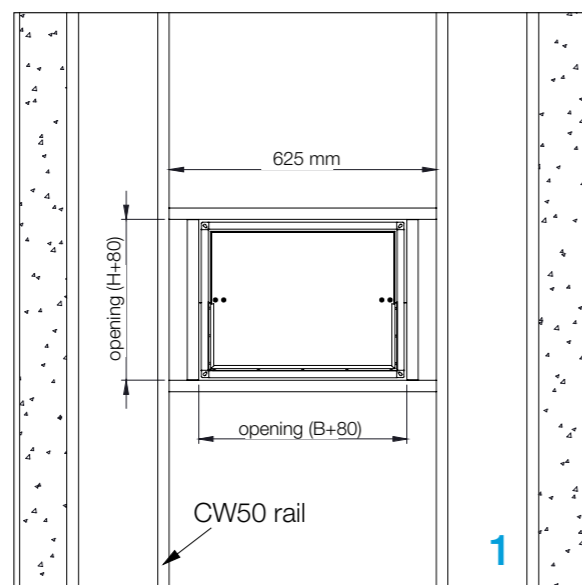

FD25, FD40 - side cross section

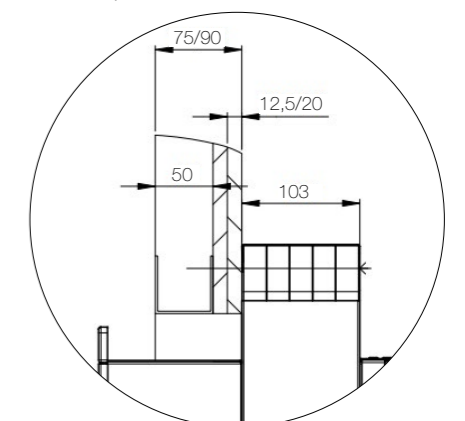

## Installation remote from the rigid wall (Promat)

The wall is composed of concrete blocks (minimum density of 450 kg/m<sup>3</sup>) or reinforced concrete (minimum density of 2200 kg/m<sup>3</sup>) and with a minimum thickness of 100 mm.

**Installation only possible with FD40!**



INSTALLATION

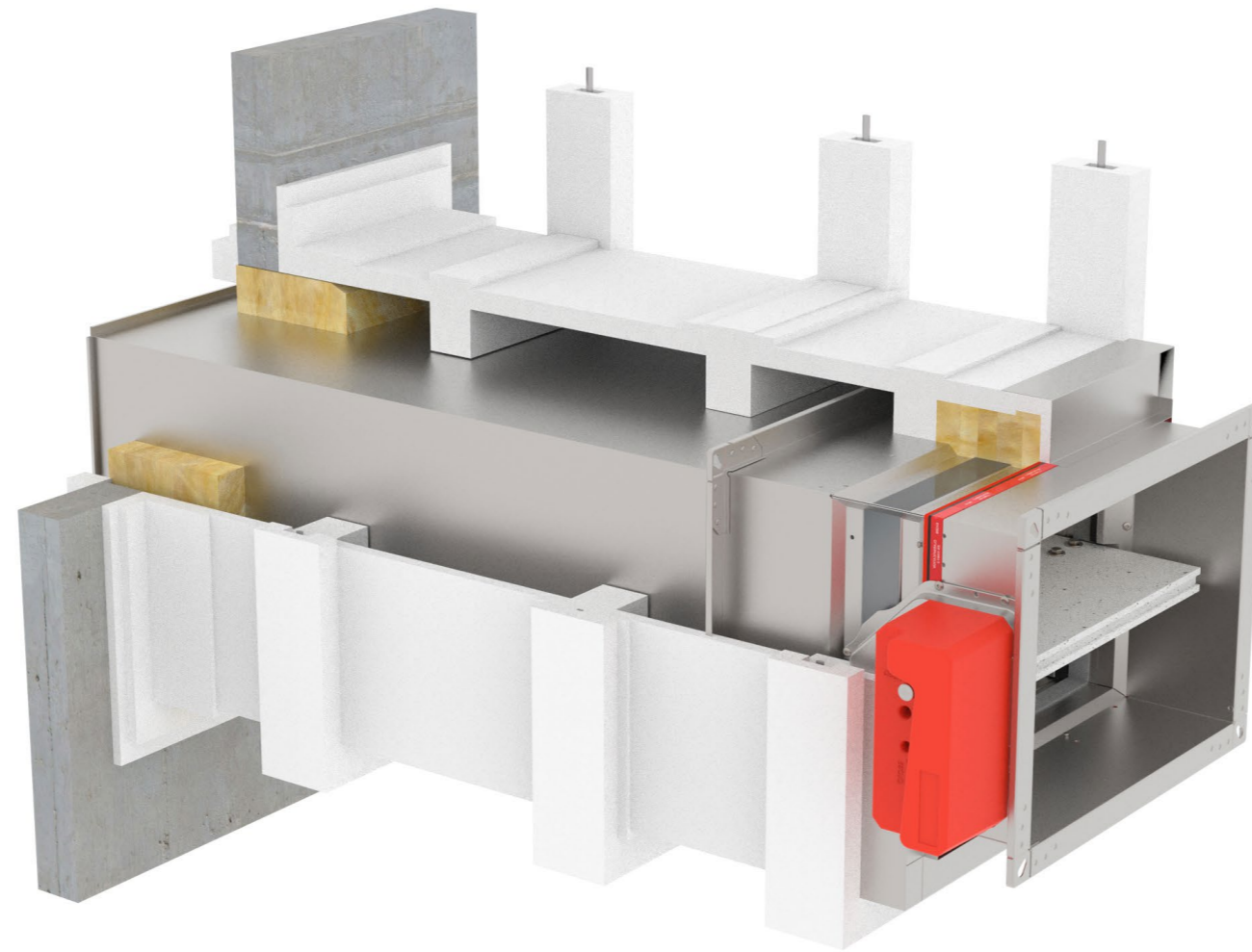

- ▼ [PRODUCT OVERVIEW](#)
- ▼ [DIMENSIONS](#)
- ▼ [INSTALLATIONS](#)
- ▼ [ACTUATORS](#)
- ▼ [ACCESSORIES](#)
- ▼ [REPLACEMENTS](#)
- ▼ [MAINTENANCE AND OPERATION](#)

Possible damper orientations



FIRE DAMPER - FD

**Always ensure the damper is sufficiently supported and a breakaway joint is incorporated between the damper and adjoining ductwork on both sides**

1. Recommended wall opening for the fire damper installation is B (H) + 100 mm. Place fire damper and duct on pre-cut calcium silicate 52 mm (Promat L500), 100 mm wide supports (max. every 1000 mm) from same material need to be used to support the duct as well as the damper.

**Damper blade must be closed during installation!**

2. Fit the duct and the damper through the wall, and cover them with 52 mm calcium silicate (Promat L500). Board corner joints must be glued with glue PROMAT K84 and connected with staples every 100 mm.

3. The gap between the damper and the wall must be filled with mineral wool (density 140 kg/m<sup>3</sup> or more). Close the mineral wool with Promatect H plates 20 mm thick. Duct and damper supporting brackets have to be insulated with 52 and 20 mm calcium silicate boards (Promatect H and L500).

**Test the operation of the damper blade!**

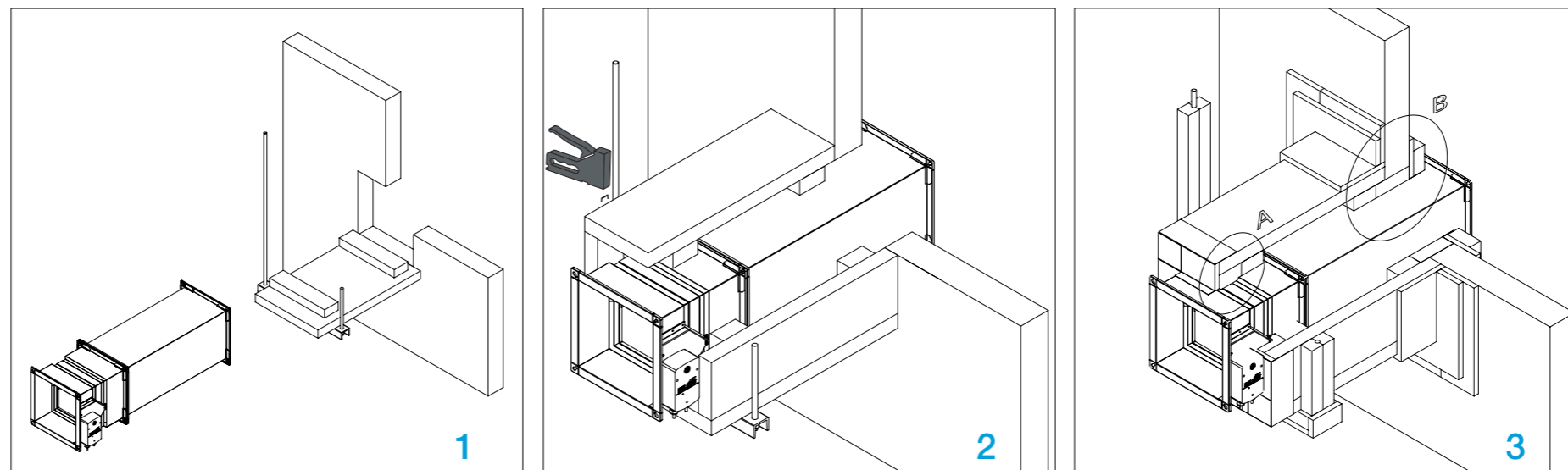

**A**

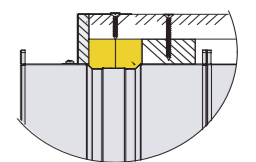

**B**

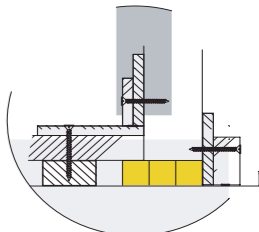

## Installation remote from flexible/rigid wall

**Flexible wall:** The wall is composed of 2x2 plasterboard boards, 12.5 mm thick, installed on a steel construction. To fulfill the classification it is **NOT** mandatory to use the mineral wool inside the wall (mineral wool with density up to 115 kg/m<sup>3</sup> can be used).

**Rigid wall:** The wall is composed of concrete blocks (minimum density of 450 kg/m<sup>3</sup>) or reinforced concrete (minimum density of 2200 kg/m<sup>3</sup>) and with a minimum thickness of 100 mm.



### INSTALLATION

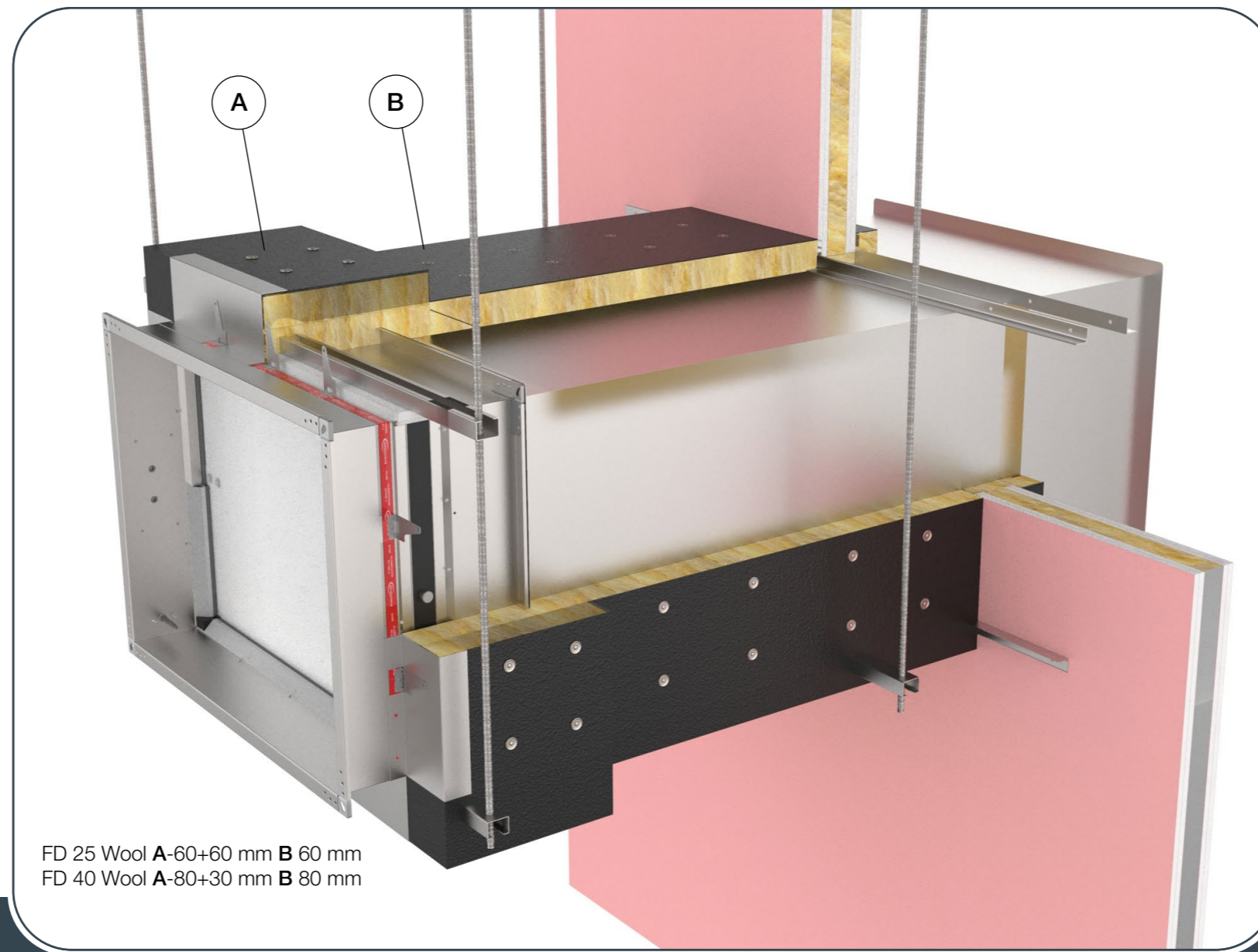

FD 25 Wool A-60+60 mm B 60 mm  
FD 40 Wool A-80+30 mm B 80 mm

- ▼ [PRODUCT OVERVIEW](#)
- ▼ [DIMENSIONS](#)
- ▼ [INSTALLATIONS](#)
- ▼ [ACTUATORS](#)
- ▼ [ACCESSORIES](#)
- ▼ [REPLACEMENTS](#)
- ▼ [MAINTENANCE AND OPERATION](#)

Possible damper orientations



FIRE DAMPER - FD

1. Place the damper in an opening (B + 80) x (H + 80). Place ventilation duct trough wall. Distance between suspensions is max. 800 mm (thickness of threaded rod for suspension should be M10 (FDC25) or M12 (FDC40)).

**Damper blade must be closed during installation!**

2. Install fire damper and secure it to ventilation duct. Space between duct and wall should be filled with (Isover U protect Slab), the same material as the ones that is used for insulation of the duct mineral wool. Additionally, paint wool with Isover BSF in thickness of 1 mm.

3. Close installation with L profiles 30x30x3 mm. Additionally fix profiles to duct with self-tapping screws, and screw them to wall with 4,5x50 screws with 200 mm distance between them. On connection wool-wall apply glue Isover BSK in thickness of 2 mm. Repeat the same procedure on the other side.

4. Secure the wool with welding nails. Nails are placed 60 mm from the end of the plate and 150 mm between each other. Isover Fire Protect Screw screws are additionally used on the corner on every 150 mm. Additionally place steel protection on place where insulation on damper ends. Place the wool on ventilation duct in length of 80 mm and secure it with welding nails. Repeat the process on the other side of the wall. **Test the operation of the damper blade!**

**\*Use MWC accessories kit for installation!**

**Always ensure the damper is sufficiently supported and a breakaway joint is incorporated between the damper and adjoining ductwork on both sides**

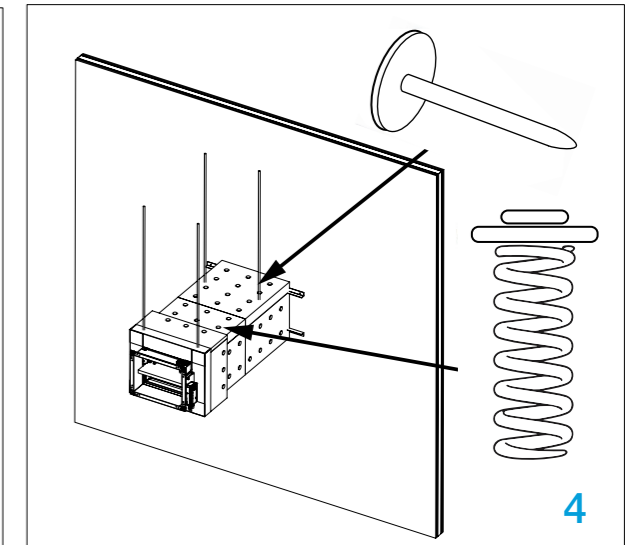
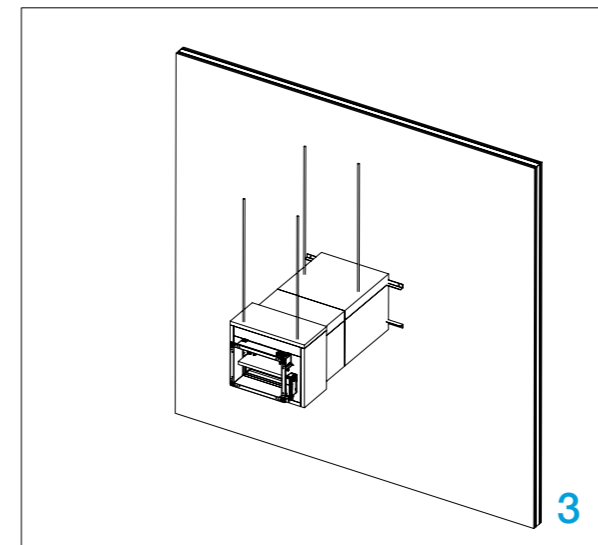
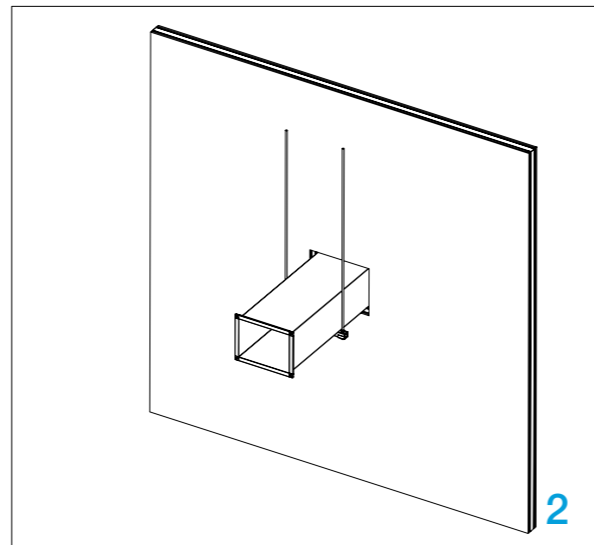
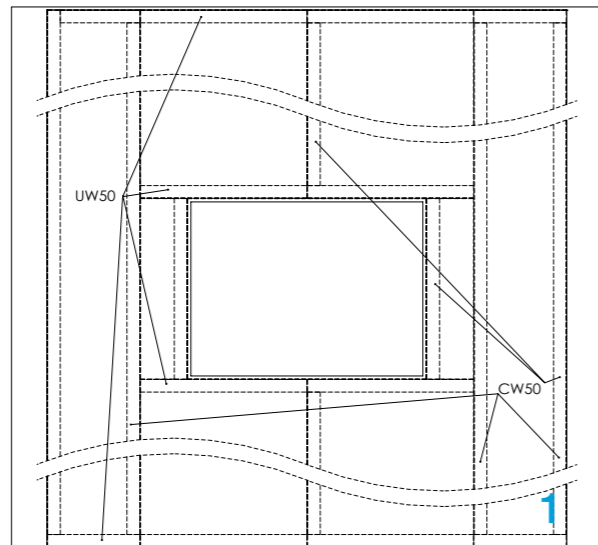

## Battery assembly installation 2x2

The wall is composed of concrete blocks (minimum density of 450 kg/m<sup>3</sup>) or reinforced concrete (minimum density of 2200 kg/m<sup>3</sup>) and with a minimum thickness of 100 mm.

**Maximum dimension of fire dampers:**  
2X2 grid: 1500x800 mm

\*For battery installation 2x2 use 8x connecting frames and 2x connecting plate.

**Installation only possible with FD40!**



### INSTALLATION

1. Prepare a hole of dimensions 2B + Connecting frame width (CF60/CF100) + 80 mm and 2H + Connecting frame width (CF60/CF100) + 80 mm. Fill the bottom with mortar/gypsum in 50 mm height.

2. Place two lower dampers in the opening, and fix dampers to the wall using screws (only 2 sides facing aerated concrete). Place the vertical part from the installation kit to the dampers on both sides, and attach it using the self-tapping screws.

**Damper blade must be closed during installation!**

3. Fill the space between the dampers and the wall with mortar/gypsum, and fill the space between the dampers with mineral wool (100 kg/m<sup>3</sup> of density or higher). Place two upper dampers and fix the dampers to the wall using the screws (only 2 sides facing aerated concrete).

4. Place the vertical part and two horizontal parts from the installation kit to the dampers on both sides, and attach it using the self-tapping screws every 150 mm. Fill the gap between dampers and wall on upper side with mortar/gypsum and the installation is complete.

**Test the operation of the damper blade!**

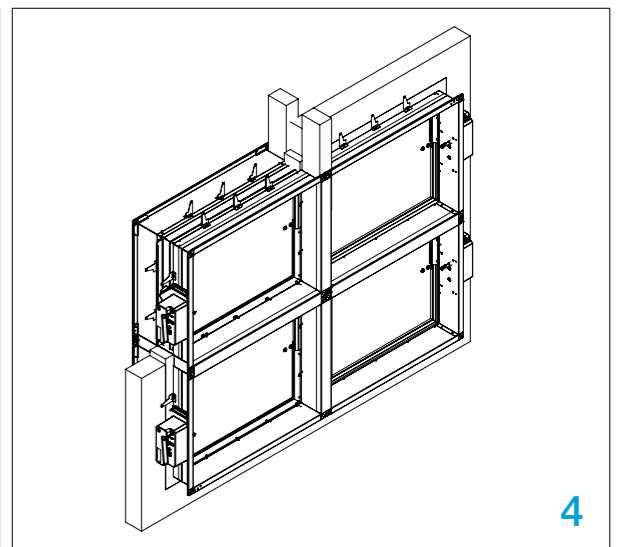
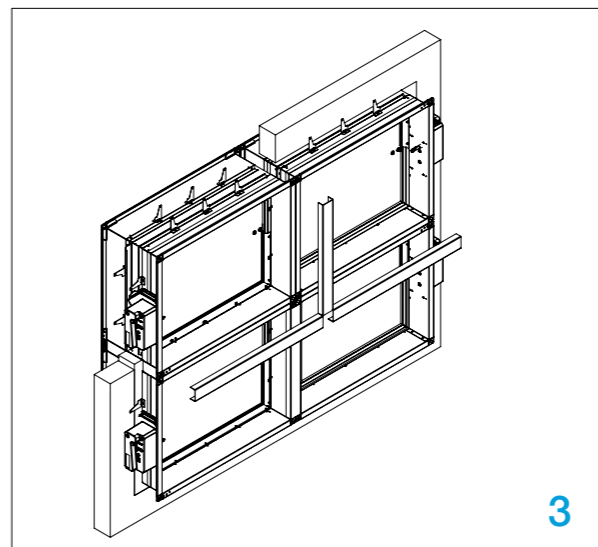
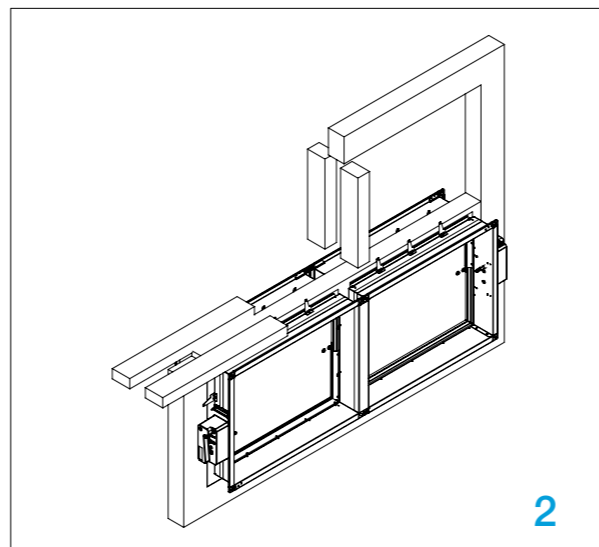
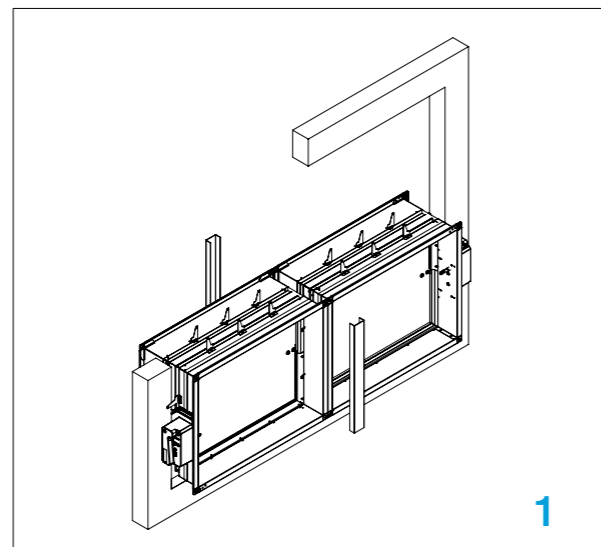

(1) Accessories (2) Type (3) Length

FD-A - CF60 - 800

(1) Fire damper accessories  
FD-A

(2) Type  
CF60 - Connecting frame 60 mm  
CF100 - Connecting frame 100 mm  
CP60 - Connecting plate 60 mm  
CP100 - Connecting plate 100 mm

(3) Connecting frame length

200 ... 1500 [mm]

- ▼ [PRODUCT OVERVIEW](#)
- ▼ [DIMENSIONS](#)
- ▼ [INSTALLATIONS](#)
- ▼ [ACTUATORS](#)
- ▼ [ACCESSORIES](#)
- ▼ [REPLACEMENTS](#)
- ▼ [MAINTENANCE AND OPERATION](#)

Possible damper orientations



FIRE DAMPER - FD

# Battery assembly installation (floor/ceiling) 2x2, 1x2, 2x1

The floor/ceiling is composed of concrete blocks (minimum density of 450 kg/m<sup>3</sup>) or reinforced concrete (minimum density of 2200 kg/m<sup>3</sup>) and with a minimum thickness of 100 mm.

**Maximum dimension of fire dampers:**  
2X2 grid: 1500x800 mm

\*For battery installation 2x2 use 8x connecting frame and 2x connecting plate.

**Installation only possible with FD40!**



## INSTALLATION

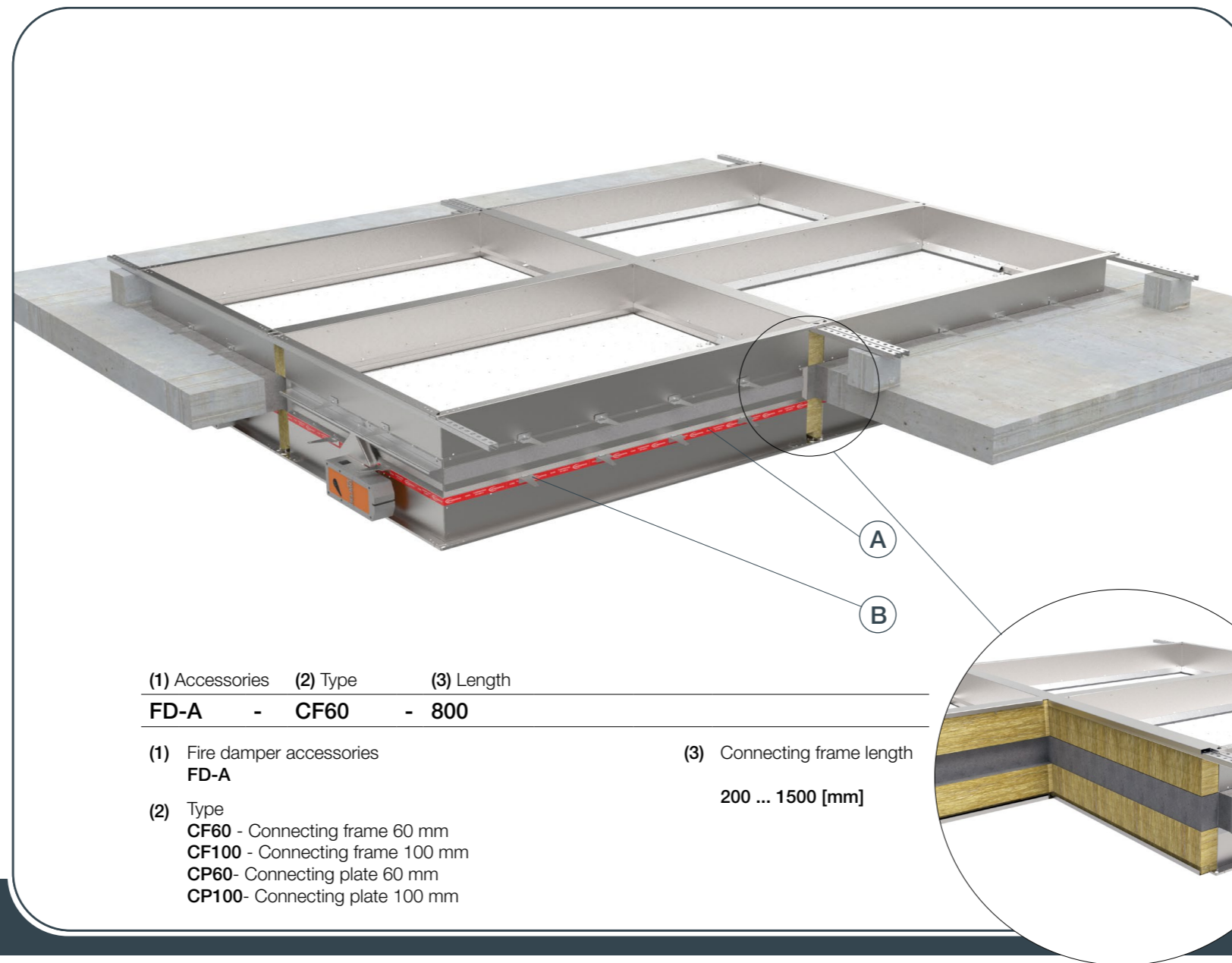

(1) Accessories	(2) Type	(3) Length
FD-A	CF60	800

(1) Fire damper accessories FD-A	(3) Connecting frame length 200 ... 1500 [mm]
(2) Type CF60 - Connecting frame 60 mm CF100 - Connecting frame 100 mm CP60 - Connecting plate 60 mm CP100 - Connecting plate 100 mm	

- ▼ [PRODUCT OVERVIEW](#)
- ▼ [DIMENSIONS](#)
- ▼ [INSTALLATIONS](#)
- ▼ [ACTUATORS](#)
- ▼ [ACCESSORIES](#)
- ▼ [REPLACEMENTS](#)
- ▼ [MAINTENANCE AND OPERATION](#)

Possible damper orientations



FIRE DAMPER - FD

**Always ensure the damper is sufficiently supported and a breakaway joint is incorporated between the damper and adjoining ductwork on both sides**

1. Prepare a hole of dimensions 2B + Connecting frame width (CF60/CF100) + 80 mm and 2H + Connecting frame width (CF60/CF100) + 80 mm. Set all U profiles to a height of 118 mm (use blocks of aerated concrete to keep distance between ceiling and profiles).

2. Arrangement of steel C profiles (27x18 mm).

3. Place the dampers in the openings to the wall limit mark (A) and bend the fixing bracket (B) 90°. Put them on U profiles. Fix the dampers and profiles to the ceiling using the screws for concrete. Place four connection profiles from the installation kit to the dampers on both sides and attach it using the self-tapping screws.

4. The space between fire dampers and wall and fire dampers themselves should be filled with mortar/gypsum in the thickness of the concrete slab. The remaining free space between damper

casings (above and below mortar filling) should be filled with mineral wool (density 100kg/m<sup>3</sup> or higher). The recommended procedure is to install the lower mineral wool between casings and use it as formwork. Install additional wooden formwork

around the perimeter of the installation between casing and concrete slab. Pour in the mortar up to the thickness of the concrete slab. When the mortar sets, fill the upper space between casings with the mineral wool. **Damper blade must be closed during installation!** **Test the operation of the damper blade!**

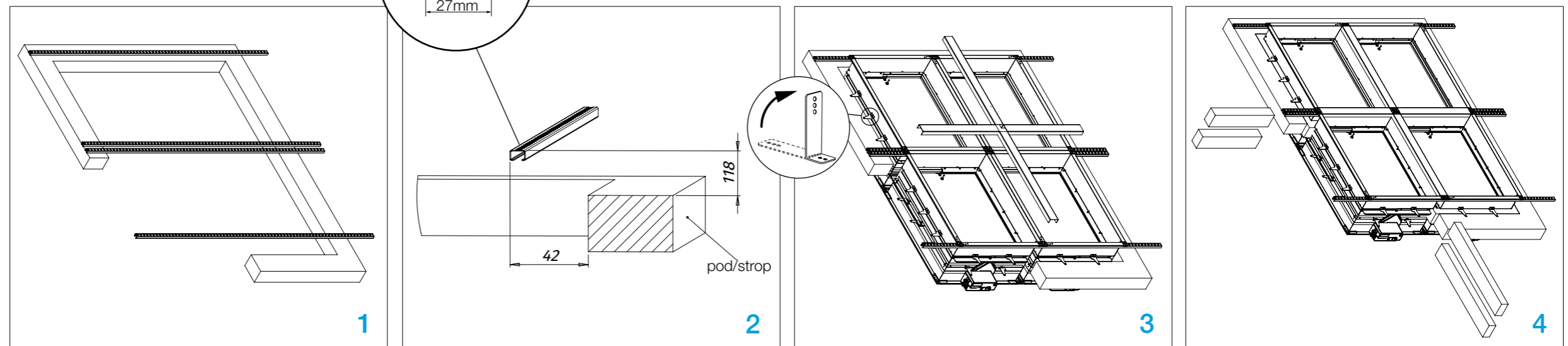

# Battery assembly installation 1x2

The wall is composed of blocks of aerated concrete (minimum density 450 kg/m<sup>3</sup>) and with a minimum thickness of 100 mm.

\*For battery installation 1x2 use 2x connecting frame.

**Installation only possible with FD40!**



## INSTALLATION

1. Prepare a hole of dimensions B + 80 mm and 2H + Connecting frame width (CF60/CF100) + 140 mm. Fix the dampers to the wall using the screws.

**Damper blade must be closed during installation!**

2. Place the installation kit to the dampers. Attach the installation kit to the dampers using the self-tapping screws every 150 mm.

3. Fill the space between the dampers with mineral wool (100 kg/m<sup>3</sup> of density).

4. Fill the space between the dampers and the wall with mortar.

Test the operation of the damper blade!

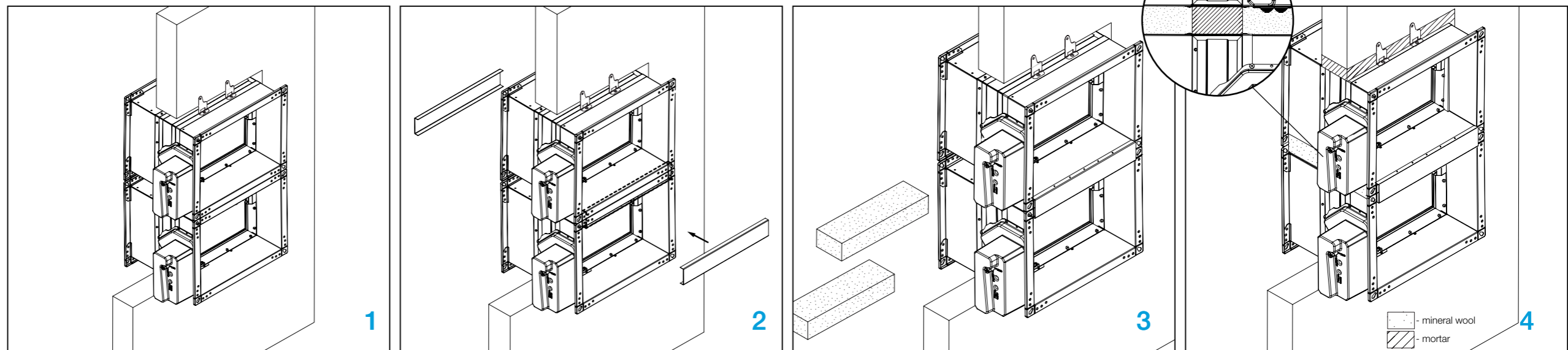

**Always ensure the damper is sufficiently supported and a breakaway joint is incorporated between the damper and adjoining ductwork on both sides**

(1) Accessories	(2) Type	(3) Length
FD-A	- CF60	- 800

(1) Fire damper accessories  
FD-A

(3) Connecting frame length  
200 ... 1500 [mm]

(2) Type  
CF60 - Connecting frame 60 mm  
CF100 - Connecting frame 100 mm

- ▼ [PRODUCT OVERVIEW](#)
- ▼ [DIMENSIONS](#)
- ▼ [INSTALLATIONS](#)
- ▼ [ACTUATORS](#)
- ▼ [ACCESSORIES](#)
- ▼ [REPLACEMENTS](#)
- ▼ [MAINTENANCE AND OPERATION](#)

Possible damper orientations



FIRE DAMPER - FD

## Battery assembly installation 2x1

The wall is composed of blocks of aerated concrete (minimum density 450 kg/m<sup>3</sup>) and with a minimum thickness of 100 mm.

\*For battery installation 2x1 use 2x connecting frame.

**Installation only possible with FD40!**



### INSTALLATION

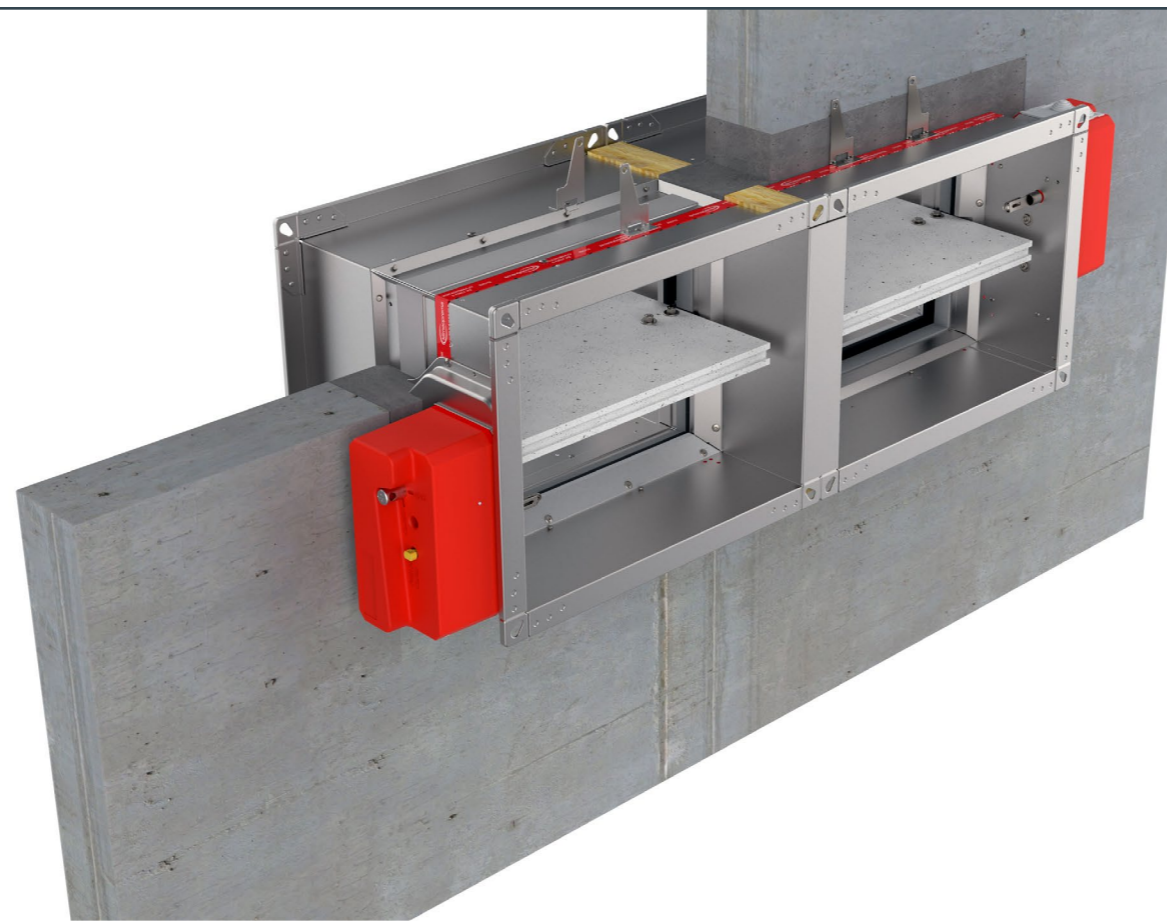

(1) Accessories	(2) Type	(3) Length
FD-A	CF60	800

(1) Fire damper accessories FD-A	(3) Connecting frame length 200 ... 1500 [mm]
(2) Type CF60 - Connecting frame 60 mm CF100 - Connecting frame 100 mm	

- ▼ [PRODUCT OVERVIEW](#)
- ▼ [DIMENSIONS](#)
- ▼ [INSTALLATIONS](#)
- ▼ [ACTUATORS](#)
- ▼ [ACCESSORIES](#)
- ▼ [REPLACEMENTS](#)
- ▼ [MAINTENANCE AND OPERATION](#)

Possible damper orientations



FIRE DAMPER - FD

**Always ensure the damper is sufficiently supported and a breakaway joint is incorporated between the damper and adjoining ductwork on both sides**

1. Prepare a hole of dimensions 2B + Connecting frame width (CF60/CF100) + 140 mm and H + 80 mm. Fix the dampers to the wall using the screws.

**Damper blade must be closed during installation!**

2. Place the installation kit to the dampers. Attach the installation kit to the dampers using the self-tapping screws every 150 mm.

3. Fill the space between the dampers with mineral wool (100 kg/m<sup>3</sup> of density).

4. Fill the space between the dampers and the wall with mortar.

**Test the operation of the damper blade!**

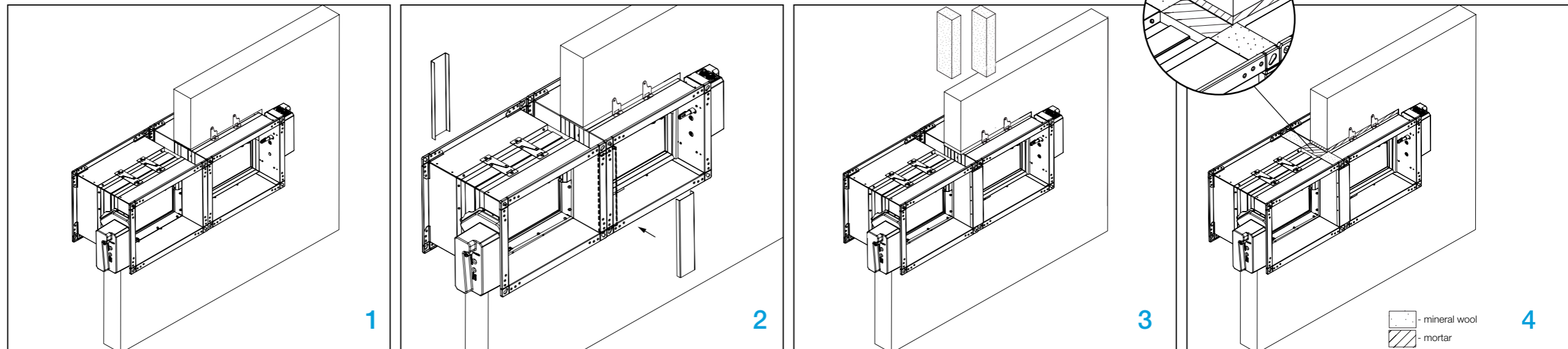

## Multiple fire dampers installation

- Material compliant with the classification from [DOP](#)
- \*Coated mineral wool (140 kg/m<sup>3</sup>) up to flanges from both sides (only in case of weichschott/firebatt)

**Damper blade must be closed during installation!**

1. Prepare opening in the wall according to B (H) + 80 mm or 50% more (Weichschott/Firebatt installation- build the subframe according to the drawing, [see page 50](#)). Fire damper can be installed with minimal distance of 30 mm between wall/ceiling and 60 mm from other dampers.
2. Insert the fire dampers into the wall and fill the space between the casings with mineral wool up to flanges. Fill the space between the wall/ceiling with mineral wool up to flanges.
3. Fill the rest of the wall openings according to the type of installation in the DOP.
4. Complete the installation according to the DOP.

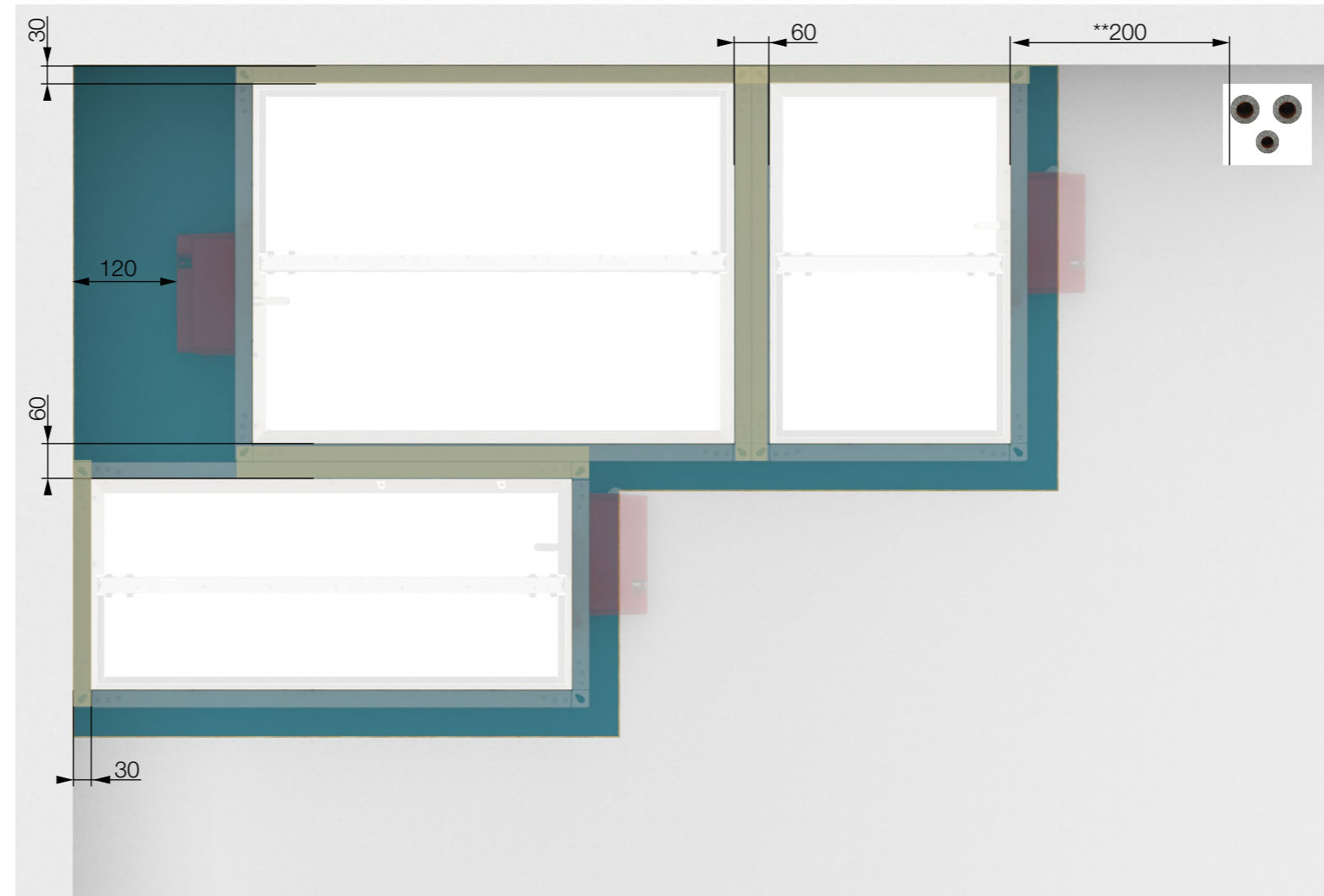

\* Minimal distances from another damper or wall/ceiling.  
\*\* Minimal distances from any other penetration through the wall.

- ▼ [PRODUCT OVERVIEW](#)
- ▼ [DIMENSIONS](#)
- ▼ [INSTALLATIONS](#)
- ▼ [ACTUATORS](#)
- ▼ [ACCESSORIES](#)
- ▼ [REPLACEMENTS](#)
- ▼ [MAINTENANCE AND OPERATION](#)



FIRE DAMPER - FD

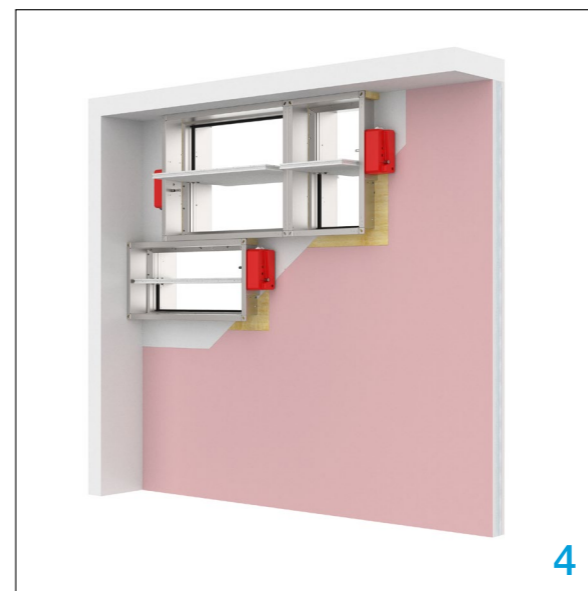
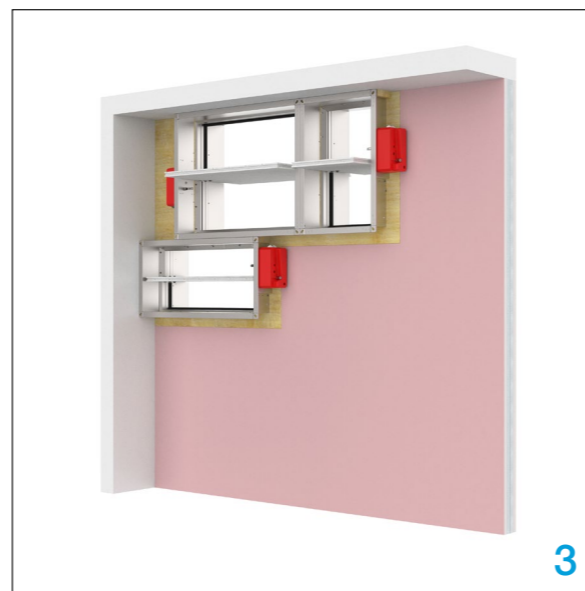
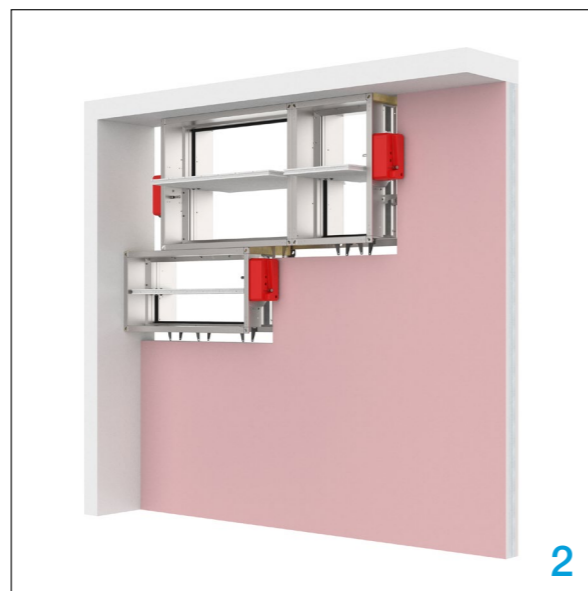
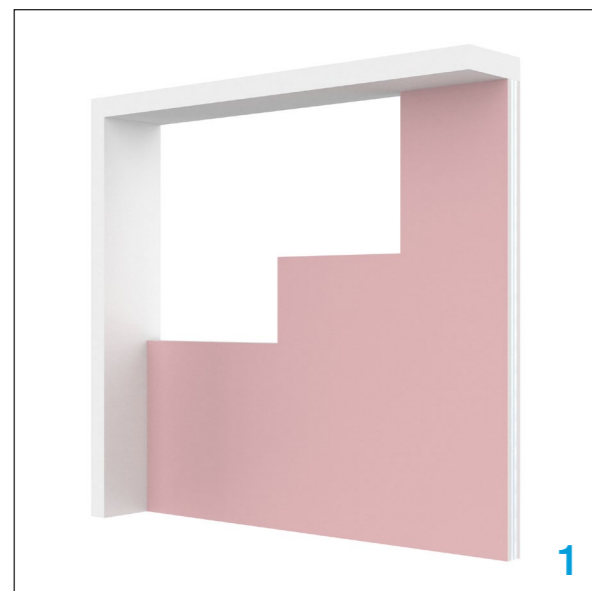

\*Examples for Weichschott/Firebatt installation

## Flexible wall subframe

When installing the fire dampers in the flexible walls it is necessary to make a metal subframe onto which the damper will be fixed with screws. Subframe should be prepared according to the drawings below.

FD25

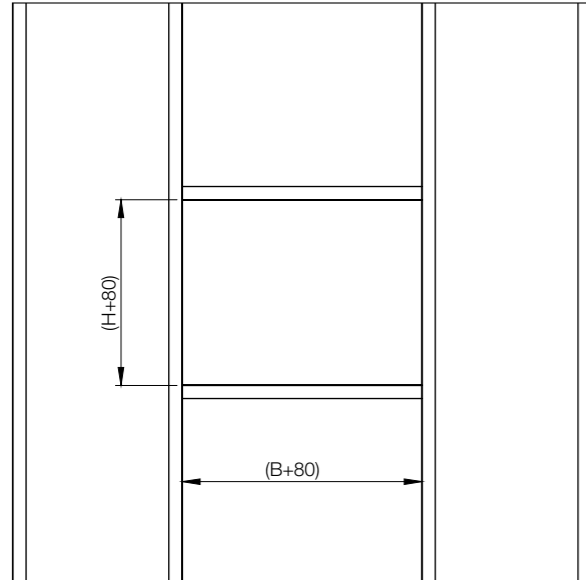

FD40

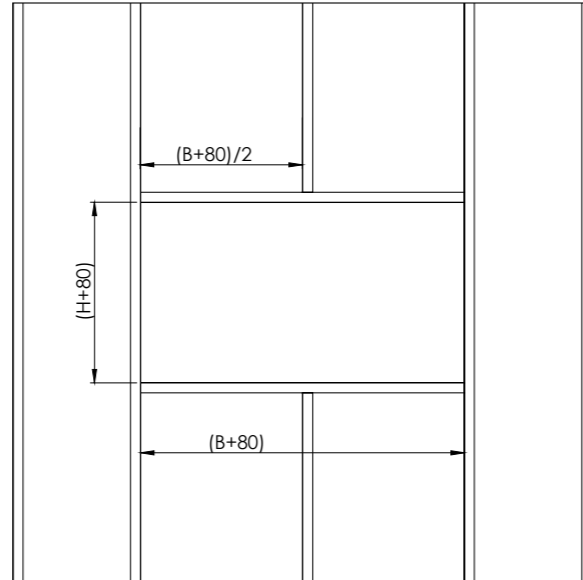

## Support for installation with mortar

In fire damper installations with mortar, it may be necessary to use wooden supports to prevent the casing from deforming while mortar is getting

hardened. Before filling the gap between wall and fire damper, close the damper blade and install the wooden supports as seen in the drawings below. **Place the wooden support as close as possible to the fire damper blade!**



- ▼ [PRODUCT OVERVIEW](#)
- ▼ [DIMENSIONS](#)
- ▼ [INSTALLATIONS](#)
- ▼ [ACTUATORS](#)
- ▼ [ACCESSORIES](#)
- ▼ [REPLACEMENTS](#)
- ▼ [MAINTENANCE AND OPERATION](#)



FIRE DAMPER - FD

## MANUAL ACTUATORS R, R-S

Manual operating mechanism, optionally with end switches (R-S). In case of fire, the fire damper closes automatically. Damper closing can be initiated either by thermal fuse melting, or by manual activation on the operating mechanism. Upon closure, damper blade is locked in closed position and can only be opened manually. Thermal fuse melting point is 72 °C.

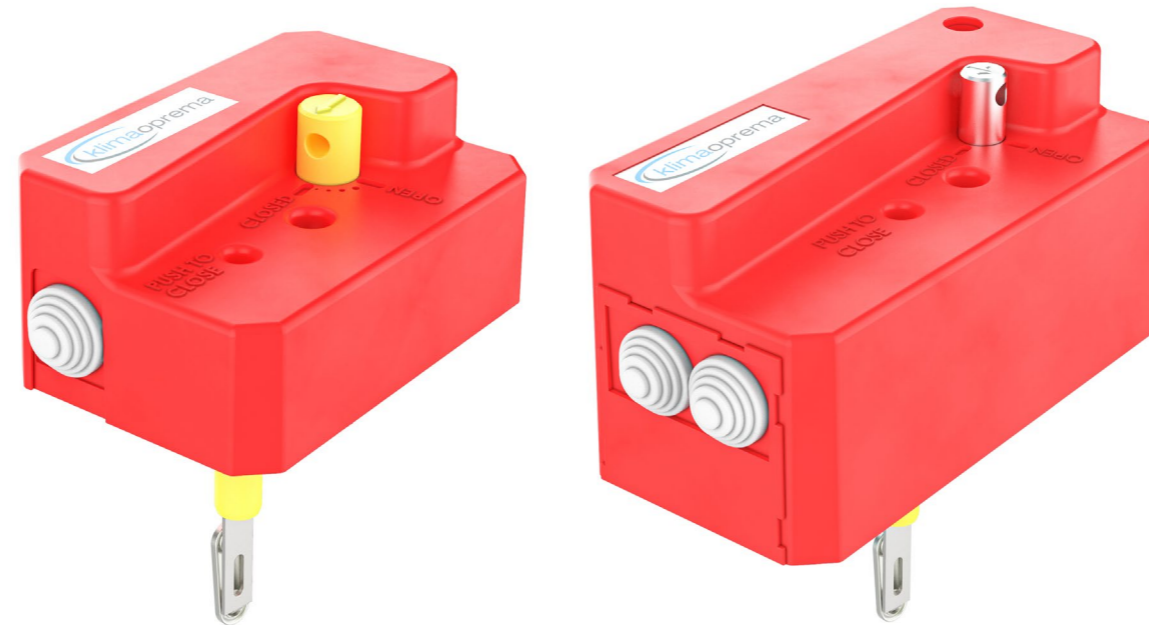

**R25**  
(up to 800x600)

**R40**  
(800x600 up to 1500x800)

- ▼ [PRODUCT OVERVIEW](#)
- ▼ [DIMENSIONS](#)
- ▼ [INSTALLATIONS](#)
- ▼ [ACTUATORS](#)
- ▼ [ACCESSORIES](#)
- ▼ [REPLACEMENTS](#)
- ▼ [MAINTENANCE AND OPERATION](#)

### R25

R25 manual actuator is installed on FD25 fire dampers range from 100x200 till 800x600. It is available in version with (R-S) and without (R) end switches. End switches and thermal fuse are easily replaceable and available as service parts. To upgrade to EMS, upgrade of R25 to R40 is required.

### R40

R40 manual actuator is installed on FD40 fire dampers from 800x600 till 1500x800. It is available in version with (R-S) and without (R) end switches. In case remote activation is needed, R40 actuator is easily upgradeable to electromagnetic EMS-S actuator with installation of the electromagnet. End switches, thermal fuse and electromagnet are easily replaceable and available as service parts.

### Technical specifications

Nominal voltage	N/A
Power	N/A
Switching capacity	1mA...500mA, 5VDC...48VDC
Blade closing time	Spring: 1 sec
Blade opening time	Manual
Manual activation	Release button on the casing
Degree of protection	IP 42
Ambient temperature range	min. -30 °C, max. 50 °C
Ambient humidity	95% r.h., non-condensing
Service life	Min. 30,000 cycles
Maintenance	Maintenance-free
Weight R25/R40	0,5 kg / 1,7 kg

### Wiring diagram

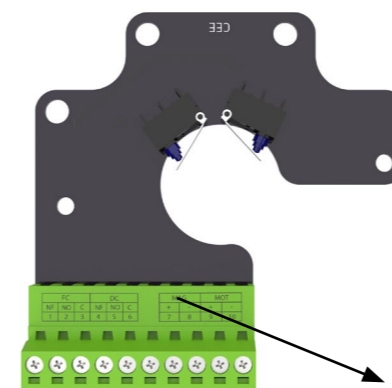

FC			DC		
NF	NO	C	NF	NO	C
11	12	13	14	15	16

FC = Limit switch - end  
DC = Limit switch - start  
NO = normally open  
NF = normally closed  
C = common

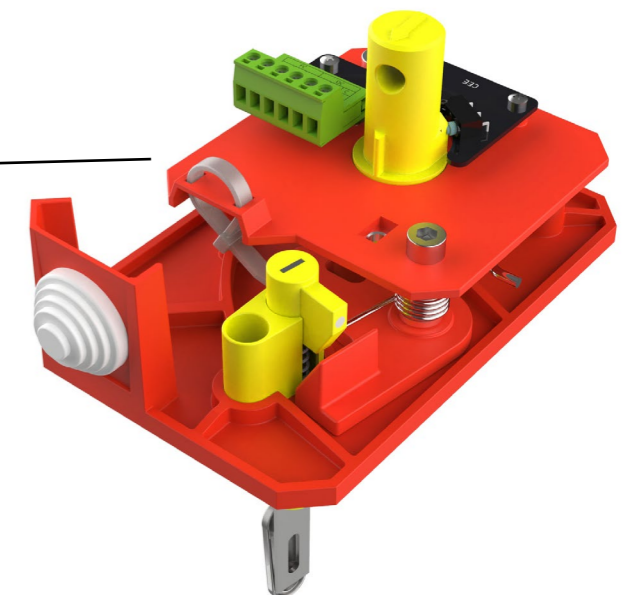
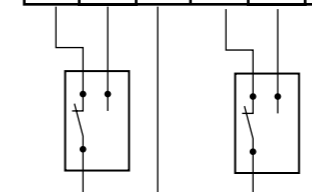

# SOLENOID ACTUATOR EMS-S

Electromagnetic operating mechanism, comes with end switches as standard. In case of fire, the fire damper closes automatically. Damper closing can be initiated either by thermal fuse melting or remotely by triggering the electromagnet. Electromagnet is constantly under power and activates closing of the damper blade in case the power cuts out. Upon closure, damper blade is locked in closed position and can only be opened manually. Thermal fuse melting point is 72 °C. EMS-S mechanism is the same for FD25/FD40 fire dampers.



- ▼ [PRODUCT OVERVIEW](#)
- ▼ [DIMENSIONS](#)
- ▼ [INSTALLATIONS](#)
- ▼ [ACTUATORS](#)
- ▼ [ACCESSORIES](#)
- ▼ [REPLACEMENTS](#)
- ▼ [MAINTENANCE AND OPERATION](#)

## Technical specifications

Nominal voltage	Solenoid: 24/48 VDC
Power	Dual voltage SOLENOID: Break of current: P <sub>nom</sub> = 1.6W
Switching capacity	1 mA...500 mA, 5 VDC...48 VDC
Blade closing time	Spring: 1 sec
Blade opening time	Manual
Manual activation	Release button on the casing
Degree of protection	IP 42
Ambient temperature range	min. -30 °C, max. 50 °C
Ambient humidity	95% r.h., non-condensing
Service life	Min. 30,000 cycles
Maintenance	Maintenance-free
Weight	2,2 kg

## Wiring diagram

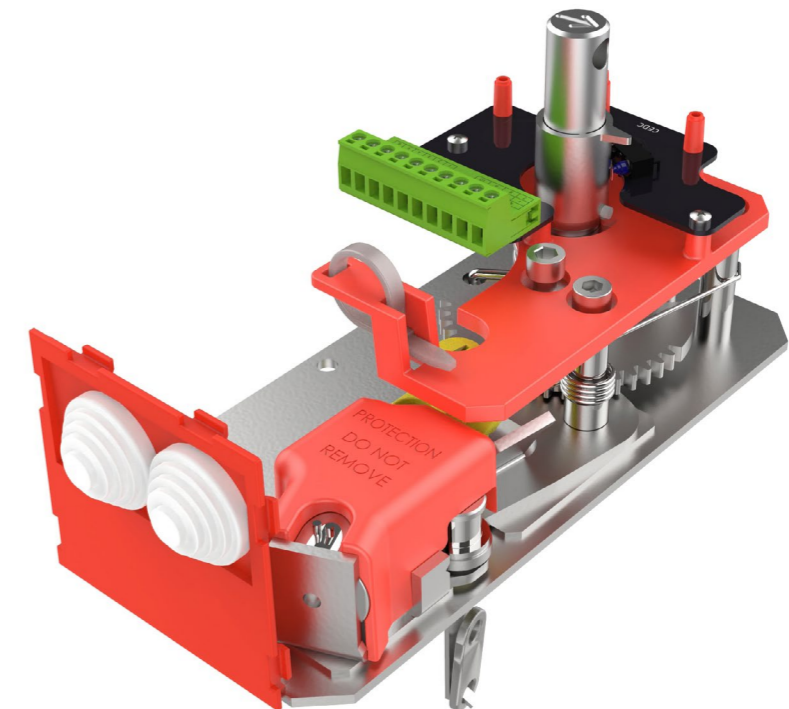
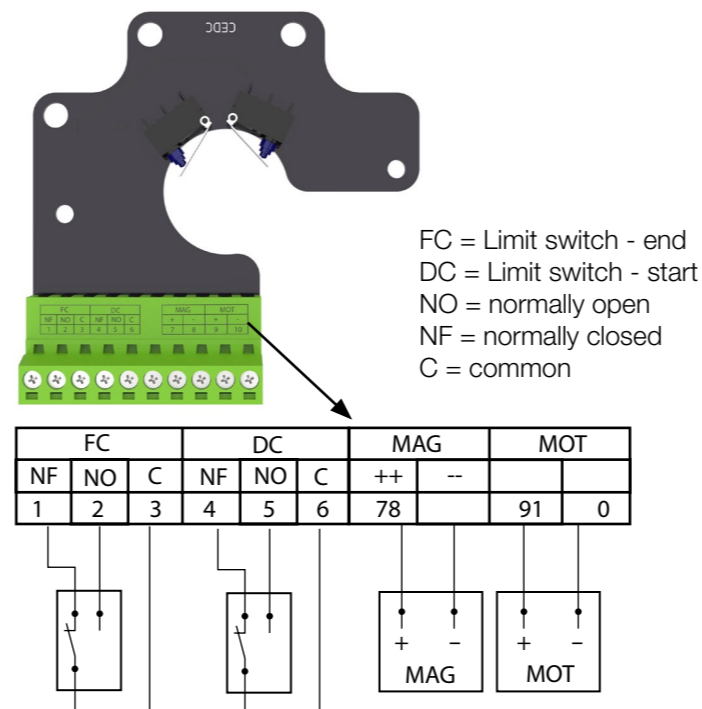

# ELECTRIC ACTUATOR M24-S, M230-S, M24-S-ST

Damper is delivered in closed position. When electric actuator is connected to the power supply damper will open. When the damper reaches the end position (damper open), the electro motor will stop. Closing fire damper takes place automatically when a power failure occurs. Thermal tripping device that comes with fire damper causes power circuit break at a temperature of 72 °C, optional 95 °C (inside or outside duct). If checking is needed for proper functioning of fire damper, pushing the switch on the thermal tripping device will close damper.



- ▼ [PRODUCT OVERVIEW](#)
- ▼ [DIMENSIONS](#)
- ▼ [INSTALLATIONS](#)
- ▼ [ACTUATORS](#)
- ▼ [ACCESSORIES](#)
- ▼ [REPLACEMENTS](#)
- ▼ [MAINTENANCE AND OPERATION](#)

When switch on tripping device is released, the damper will open. Damper can be opened without connecting to a voltage with enclosed handle turning in the direction of the arrow on electric actuator (clockwise). Damper can be locked in the desired position by fast turning back handle a quarter of a turn (counter clockwise) for Belimo BF, and by pulling brake on Belimo BFL and BFN.

To unlock the electro motor, turn handle clockwise for a quarter of a turn for Belimo BF, or release brake for Belimo BFL and BFN. After release, damper will be closed by return spring. When damper is opened manually, electric actuator will not move the damper into closed position in case of power failure.

## Technical specifications

Type of Belimo actuator	BFL24-T	BFN24-T	BFL230-T	BFN230-T	BF24-T	BF230-T	
voltage	AC/DC 24 V, 50/60 Hz	AC 24 V, 50/60 Hz	AC 230 V, 50/60 Hz	AC 230 V, 50/60 Hz	AC/DC 24 V, 50/60 Hz	AC 230 V, 50/60 Hz	
Nominal voltage / power	opening	2,5 W	4 W	3,5 W	5 W	7 W	8,5 W
	holding	0,8 W	1,4 W	1,1 W	2,1 W	2 W	3 W
for wire sizing	4 VA	6 VA	6,5 VA	10 VA	10 VA	11 VA	
End switch	1 mA...3 A (0,5 A), DC 5 V... AC 250V	1 mA...3 A (0,5 A), DC 5 V... AC 250 V	1 mA...3 A (0,5 A), DC 5 V... AC 250 V	1 mA...3 A (0,5 A), DC 5 V... AC 250 V	1 mA...6 A (3 A), DC 5 V... AC 250 V	1 mA...3 A (0,5 A), DC 5 V... AC 250 V	
	motor	< 60 s	< 60 s	< 60 s	< 60 s	< 120 s	< 120 s
Running time	spring return	~ 20 s	~ 20 s	~ 20 s	~ 20 s	~16 s	~16 s
	Ambient temperature range	min. -30 °C, max. 50 °C					

## Wiring diagram

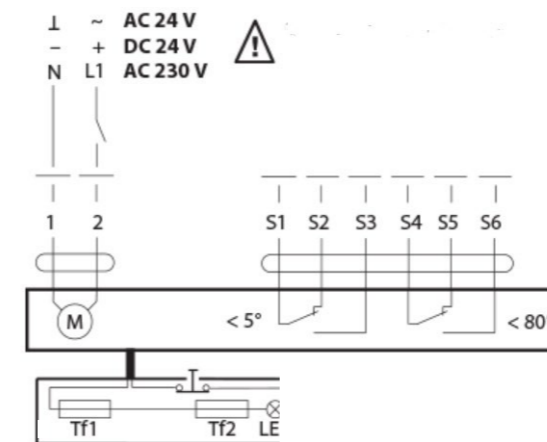

- 1 negative (direct-current) or neutral (alternating current)
- 2 positive (direct-current) or faze (alternating current)
- S1 common micro switch closed damper
- S2 normally closed micro switch closed damper
- S3 normally open micro switch closed damper
- S4 common micro switch open damper
- S5 normally closed micro switch open damper
- S6 normally open micro switch open damper
- Tf temperature sensor on the outer side of the duct (ambient temperature) max. 72 °C

# ELECTRIC ACTUATOR

## Position of thermal fuse

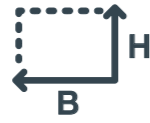

### H < 300

Thermal fuse is located on the underside of the fire damper.

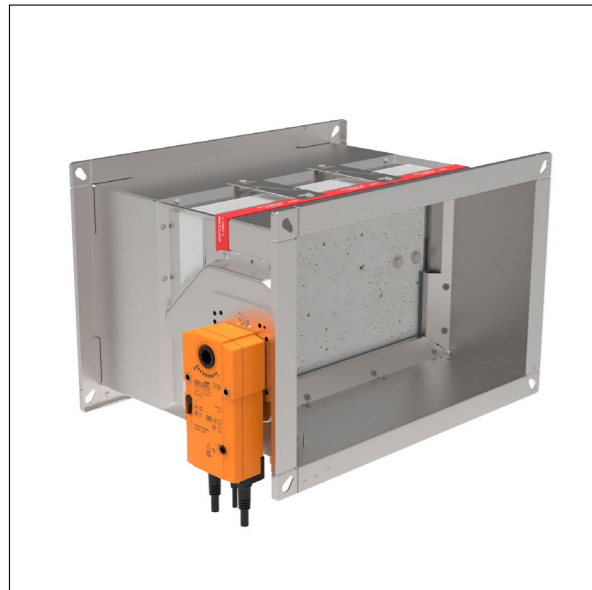

Bottom view

### 300 ≤ H ≤ 450

Thermal fuse is located on the same side as Belimo actuator (above).

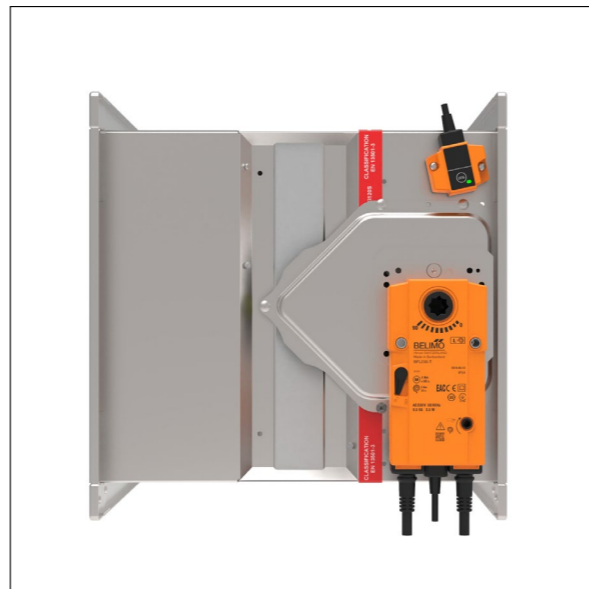
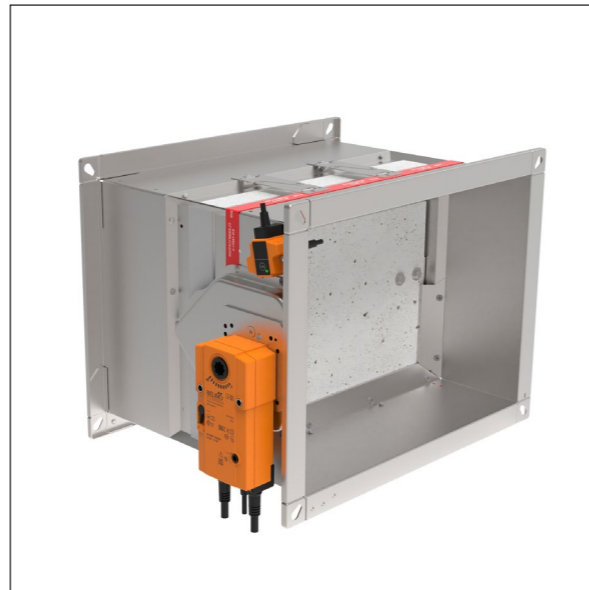

Side view

### H > 450

Thermal fuse is located on the same side as Belimo actuator (below).

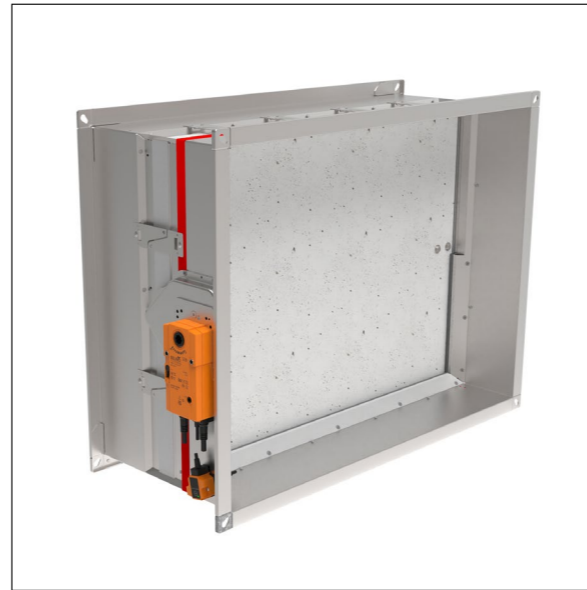

Side view

- ▼ [PRODUCT OVERVIEW](#)
- ▼ [DIMENSIONS](#)
- ▼ [INSTALLATIONS](#)
- ▼ [ACTUATORS](#)
- ▼ [ACCESSORIES](#)
- ▼ [REPLACEMENTS](#)
- ▼ [MAINTENANCE AND OPERATION](#)



FIRE DAMPER - FD

# ELECTRIC ACTUATOR SCHISCHEK ExMax

Damper is delivered in closed position. When electric actuator is connected to the power supply damper will open. When the damper reaches the end position(damper open), in which is it blocked, the electric actuator will stop. Closing fire damper takes place automatically when a power failure occurs. Thermal tripping device that comes with fire damper causes power circuit break at a temperature of 72 °C (inside or outside duct).  
If checking is needed for proper functioning of fire

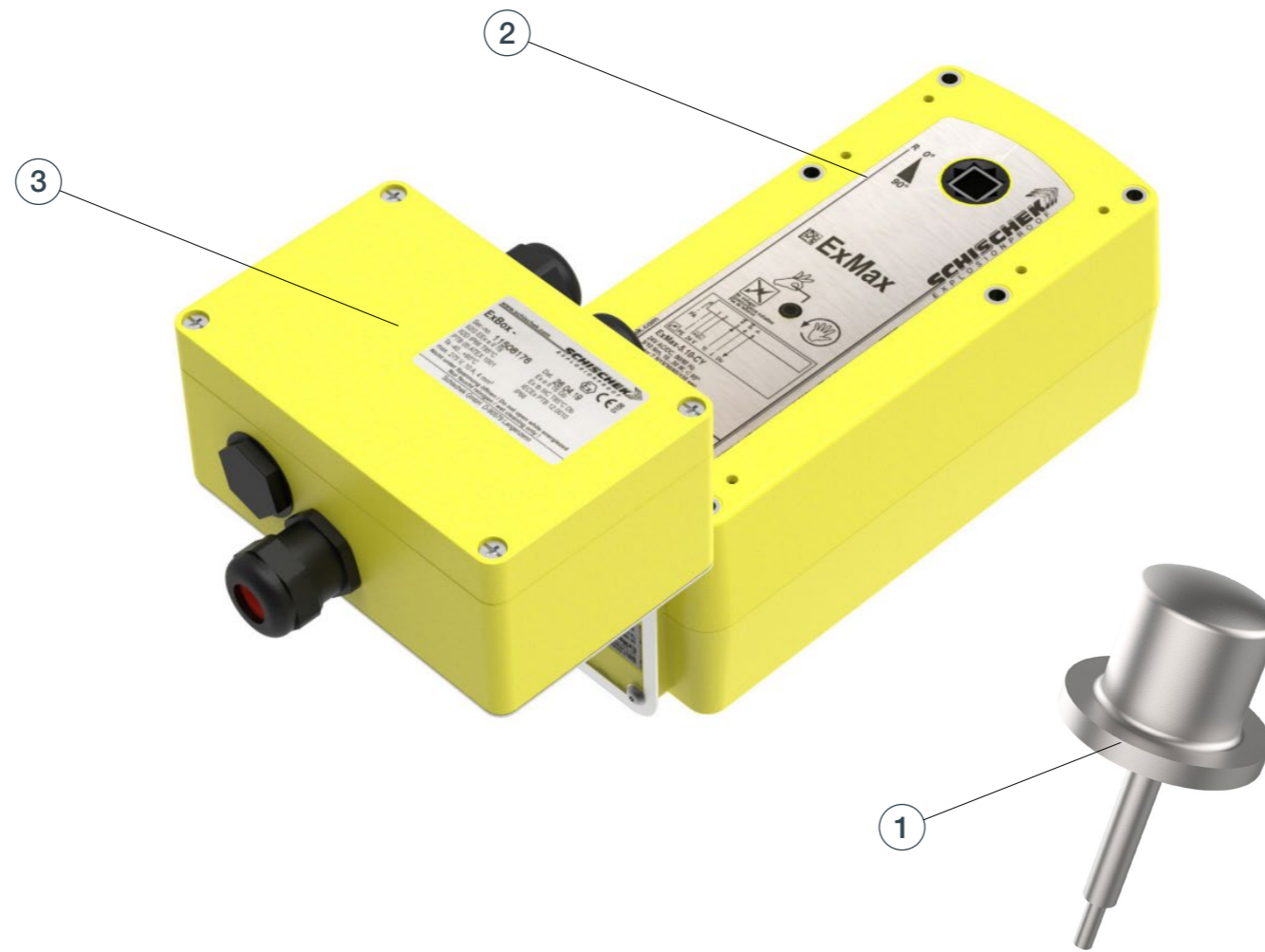

- ▼ [PRODUCT OVERVIEW](#)
- ▼ [DIMENSIONS](#)
- ▼ [INSTALLATIONS](#)
- ▼ [ACTUATORS](#)
- ▼ [ACCESSORIES](#)
- ▼ [REPLACEMENTS](#)
- ▼ [MAINTENANCE AND OPERATION](#)

damper, pushing the switch on the thermal tripping device will close damper. When switch on tripping device is released, the damper will open. Damper can be opened without connecting to a voltage with enclosed Allen key, by turning in the direction of the arrow on electric actuator (clockwise). After release of Allen key, damper will go to closed position.

- 1) [Technical documentation Safety temperature trigger Schischek ExPro-TT](#)
- 2) [Technical documentation electric actuator Schischek ExMax-5.10-BF](#)
- 3) [Technical documentation Ex-e terminal box ExBox-BF](#)

## Technical specifications

Type	ExMax -5.10-BF
Torque	5/10 Nm
Power Supply	24-230 V AC/DC
Running time	3/15/30/60/120 s / 90°
Spring return	3 or 10s / 90°
Control mode	On-Off, 3 position
Feedback	2 x aux switches + Ex. tripping device
Ambient temperature range	min. -40 °C, max. 40 °C
Ambient humidity	0-90% r.h., non-condensing
Service life	Min. 10,000 cycles @ 10 s, min 1000 cycles @ 1s
Maintenance	Maintenance-free
Weight	3,5 kg

## Wiring diagram

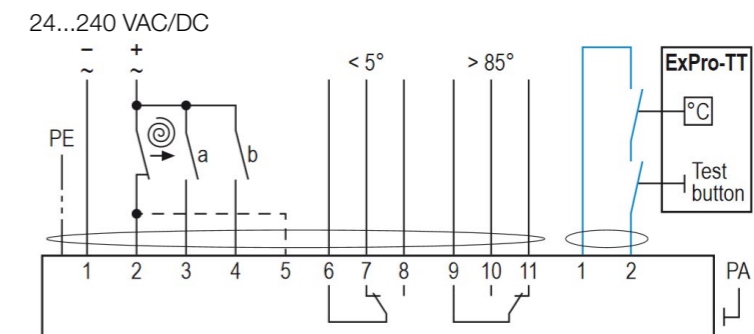

## ACCESSORIES

1 **Safety grill**- Fire damper, safety grille and, if applicable, extension piece are assembled at the factory to form a unit. The free cross sectional area of the cover grille is approx. 70%.

2 **Flexible duct connections** - Flexible duct connectors are used in HVAC systems for isolation from structure-borne noise, expansion compensation and fire damper connections (total length 130 mm, flexible 70 mm).

3 **Extension piece on operation side** - Equipped with inspection hatch

4 **Communication module bracket.**

5 **GKF boards for dry installation** - Calcium silicate plates are used in dry installations as insulation cover. It keeps the insulation in place and provides for better fire penetration characteristics of the whole installation. Cover the complete perimeter around fire damper from both sides with boards in 150 mm height.

6 **Extension piece on installation side** (250 mm)

7 **Circular connections** - Are used to connect the circular ventilation ducts to the rectangular fire dampers.

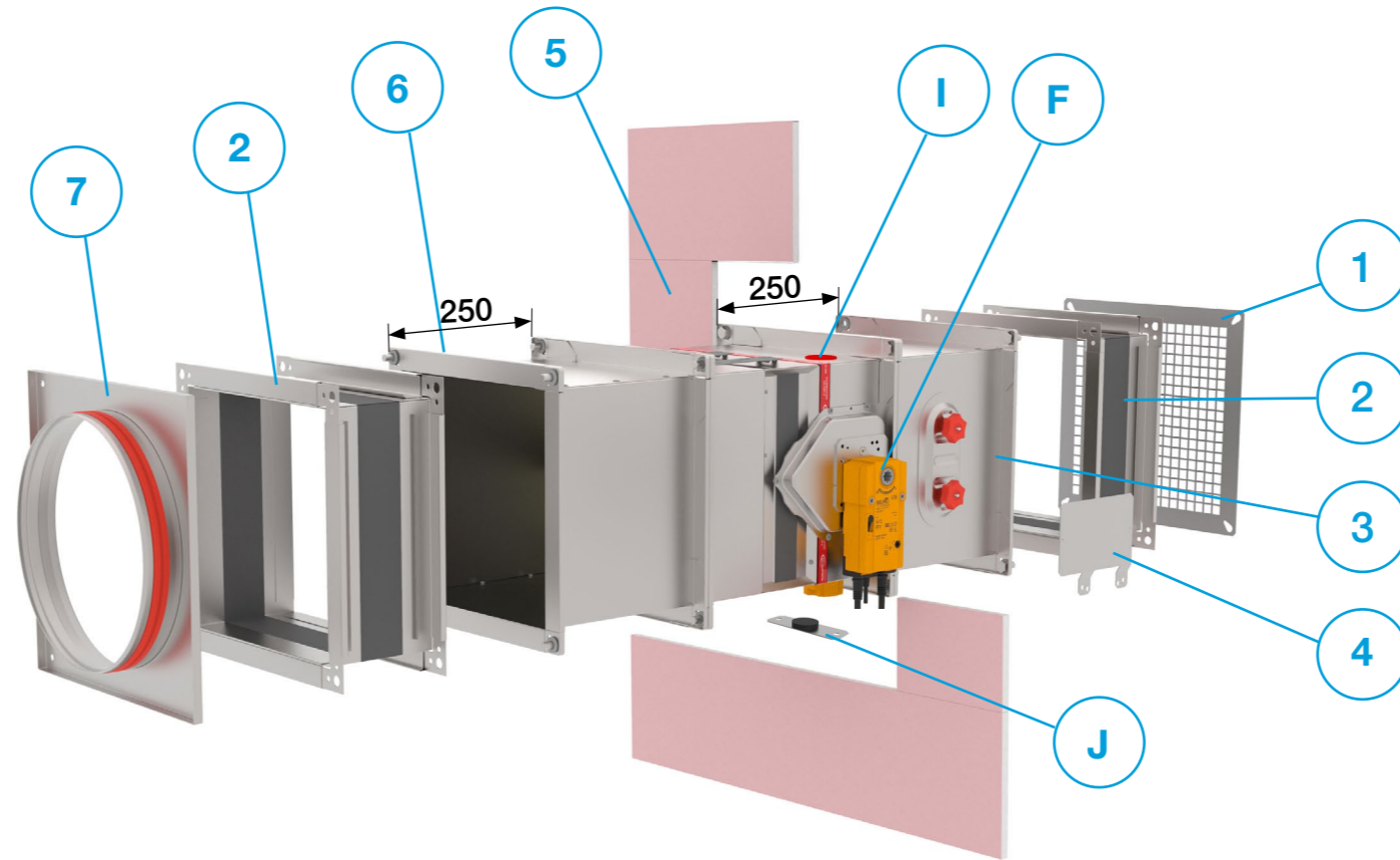

(1) Type            (2) Accessories    (3) Dimension

**FD-A - CSP - 800x600**

(1) **FD-A** accessories for rectangular fire damper

(2) **SG1** - Safety grill on operation side  
**SG2** - Safety grill on installation side  
**FLEX** - Flexible duct connections (1 pc)  
**EXT1** - Extension piece on operation side (with inspection hatch)  
**EXT2** - Extension piece on installation side (250 mm)

**CMB** - Communication module bracket  
**CSP** - GKF boards kit (for both sides of the installation)  
**CIRC** - Circular connection

(3) BxH nominal size of the rectangular fire damper

- ▼ [PRODUCT OVERVIEW](#)
- ▼ [DIMENSIONS](#)
- ▼ [INSTALLATIONS](#)
- ▼ [ACTUATORS](#)
- ▼ [ACCESSORIES](#)
- ▼ [REPLACEMENTS](#)
- ▼ [MAINTENANCE AND OPERATION](#)

## + ACCESSORIES

## FIRE DAMPER - FD

## SPARE PARTS

Spare parts are shown in the table above.  
 For safety reasons, parts need to be changed by a trained personnel or the manufacturer.

**WARNING! Install the original parts only!**

- A **Fuse kit** FD-A-THERM-72
- B **Double contact S kit** FD-A-R25S-KIT
- B\***Double contact S kit** FD-A-R40S-KIT - [see page 48.](#)
- C **Solenoid actuator** FD-A-EMS-KIT
- D **Belimo thermal fuse 72°C** FD-A-BAT72
- E **Belimo thermal fuse 95°C** FD-A-ZBAT95
- F **Kit A** Upgrade to electric actuator (Belimo BFL)
- G **Kit B** Upgrade to electric actuator (Belimo BFN)
- H **Kit C** Upgrade to electric actuator (Belimo BF)
- I **Inspection hatch** FD-A-IH (Not available with MF, App frame)
- J **Thermal fuse blanking plate** FD-BP-KIT
- K **R40 manual mechanism** FD-A-R40 - [see page 47.](#)
- L **Electric actuator rotation kit** FD-A-ERK - [see page 61.](#)
- M **Smoke sensor** spare parts - [see page 53.](#)
- N **Mineral wool cover (for remote installation)**- MWC- [see page 40.](#)

A



B



C

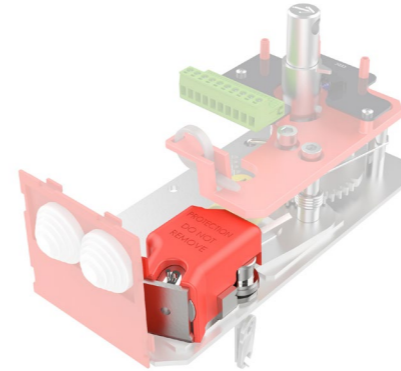

D



E



## SMOKE SENSOR ASSEMBLY FD-SSA

Smoke sensor assembly is developed to detect smoke in ventilation ducts and combines a smoke detector and an adaptor system where both tube and housing are specially designed for optimum airflow through the smoke detector. Smoke sensor provides the signal for the fire damper which is activated when smoke is detected. Smoke sensor assembly consists of casing (length: 415 mm), smoke sensor and specially designed venturi pipe inside the duct.

For proper functioning of the smoke sensor (as it is physically connected as in the render above) a straight length of 5 times hydraulic diameter, in the size of the connecting duct, should be in front of the sensor. When the sensor is installed separate from the fire damper there are two conditions to be met:

- 1) Length of 5 times hydraulic diameter, in the size of the connecting duct, should be in front of the sensor.
- 2) Length of 3 times hydraulic diameter, in the size of the connecting duct, should be after the sensor.  
 $dh=(2xHxB)/(H+B)s$ , dh - hydraulic duct diameter.

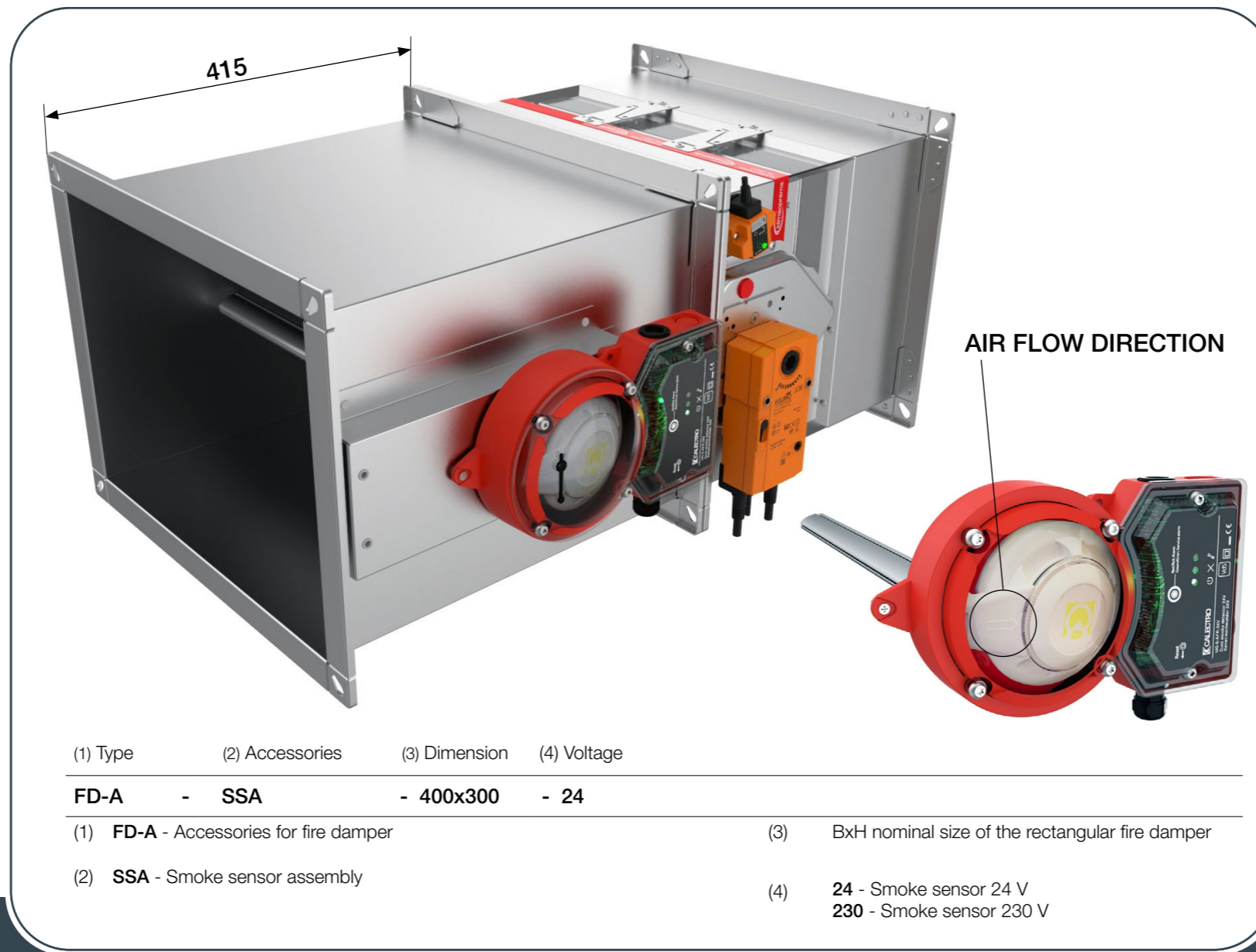

(1) Type                      (2) Accessories                      (3) Dimension                      (4) Voltage

**FD-A**      -      **SSA**                      -      **400x300**      -      **24**

- |   |  |
|---|--|
| (1) <b>FD-A</b> - Accessories for fire damper | (3) BxH nominal size of the rectangular fire damper                  |
| (2) <b>SSA</b> - Smoke sensor assembly        | (4) <b>24</b> - Smoke sensor 24 V<br><b>230</b> - Smoke sensor 230 V |

- ▼ [PRODUCT OVERVIEW](#)
- ▼ [DIMENSIONS](#)
- ▼ [INSTALLATIONS](#)
- ▼ [ACTUATORS](#)
- ▼ [ACCESSORIES](#)
- ▼ [REPLACEMENTS](#)
- ▼ [MAINTENANCE AND OPERATION](#)

### + ACCESSORIES

### FIRE DAMPER - FD

## Spare parts

- Smoke sensor FD-A-UG-5-AFR-24V
- Smoke sensor FD-A-UG-5-AFR-230V
- A Sampling tube FD-A-ST5
- B Rubber gasket FD-A-HFU204
- C Isolation extension FD-A-HFU500

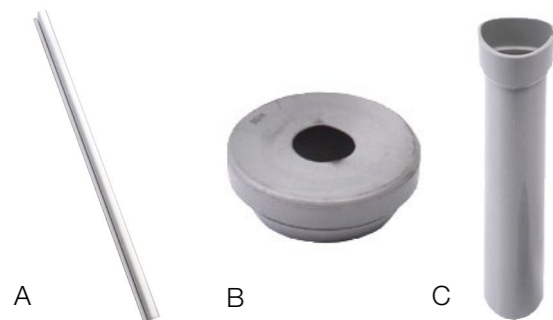

For more information, visit website:  
[Technical documentation Calectro](#)

## Technical specifications

	FD-A-UG-5-AFR-24V	FD-A-UG-5-AFR-230V
Voltage Supply	24V AC/DC -15%, +10% Not polarity sensitive	230V AC -15%, +10% Not polarity sensitive
Detector type	Optical UG-5-AFR-24V	Optical UG-5-AFR-230V
Max. power consumption	220 mA	30 mA
Operating temperature	-10°C to +55°C	
Maximum humidity	99% rH	
Duct air velocity range	1 to 20 m/s	
Approvals	VdS CE, EN-54-27	
Relay output	Potential free	
Smoke alarm relays	Two changing contacts 250V, 8A	
Service alarm	One breaking contact 250V, 5A	
System error alarm	One breaking contact 250V, 5A	
Low Flow alarm:	One breaking contact 250V, 5A	
LED on smoke detector:	Green - service alarm (contamination) Red - smoke alarm	
LED on PCB:	Green - normal operation Yellow - system error Yellow - Low-Flow	

## Wiring diagram

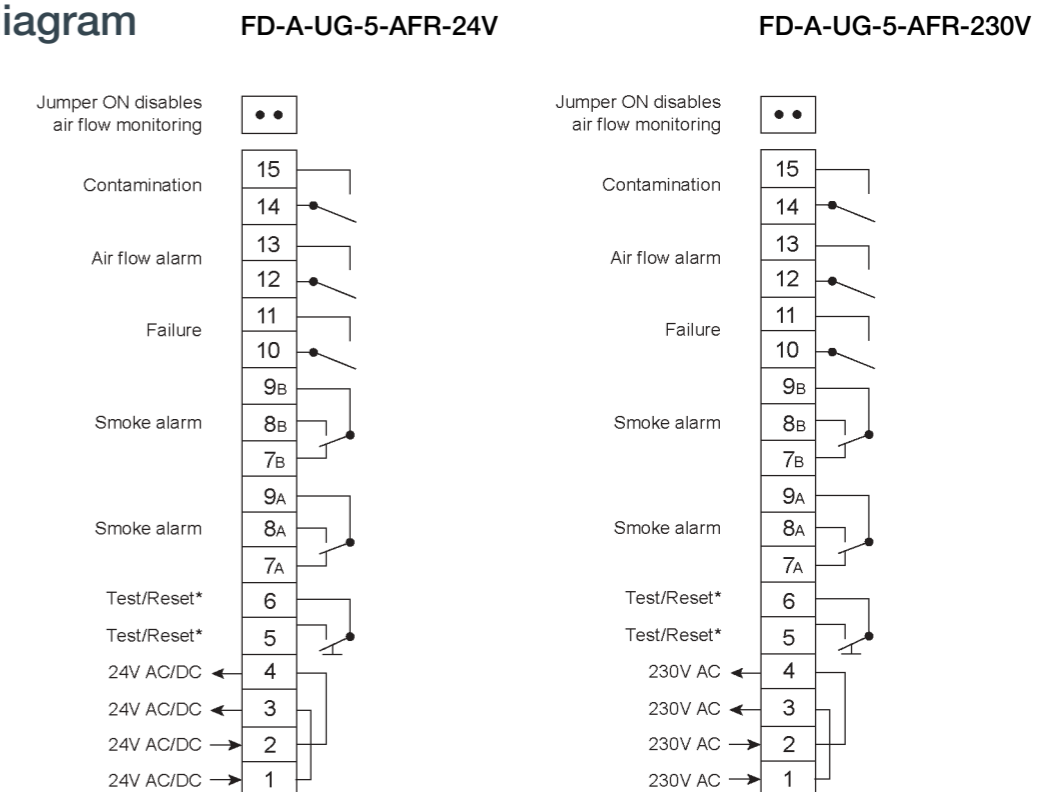

## SMOKE SENSOR CASING ROTATION

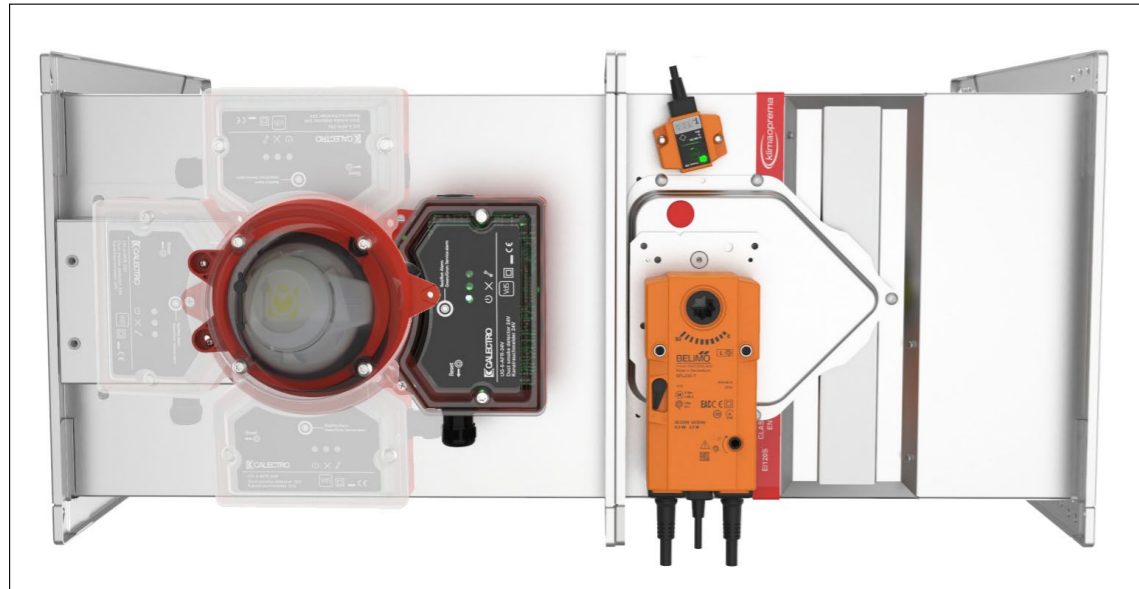

Smoke sensor casing can be rotated (90°-180°-270°) in order to provide better flexibility for wiring.  
To rotate smoke sensor casing, follow the below instructions.

1. Follow first step of **smoke sensor rotation**: locate and remove hex screws.
2. Rotate the smoke sensor casing (90°-180°-270°).
3. Fix the screws following the fourth step of **smoke sensor rotation**.

- ▼ [PRODUCT OVERVIEW](#)
- ▼ [DIMENSIONS](#)
- ▼ [INSTALLATIONS](#)
- ▼ [ACTUATORS](#)
- ▼ [ACCESSORIES](#)
- ▼ [REPLACEMENTS](#)
- ▼ [MAINTENANCE AND OPERATION](#)

↻ [REPLACEMENTS](#)

FIRE DAMPER - FD

## SMOKE SENSOR ROTATION

Smoke sensor assembly is supplied in standard airflow direction.

\*If you rotate the smoke sensor, the distance of 5 times the hydraulic duct diameter should be left before the sensor!

1. Locate hex screws, unscrew them and remove the cover.  
**Pay attention to detail A!**
2. Remove the casing, locate the screws and remove them.
3. Rotate smoke sensor (0°-180°) according to air flow direction and fix it with screws.
4. Put the casing back and install the cover. **Pay attention to detail A!**

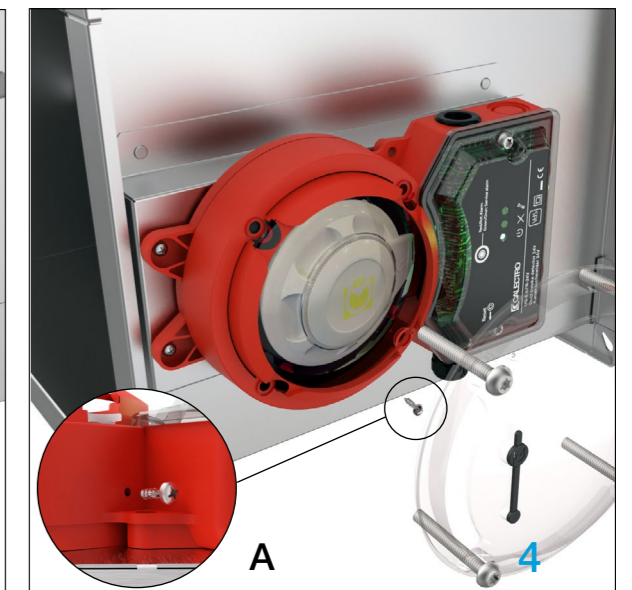
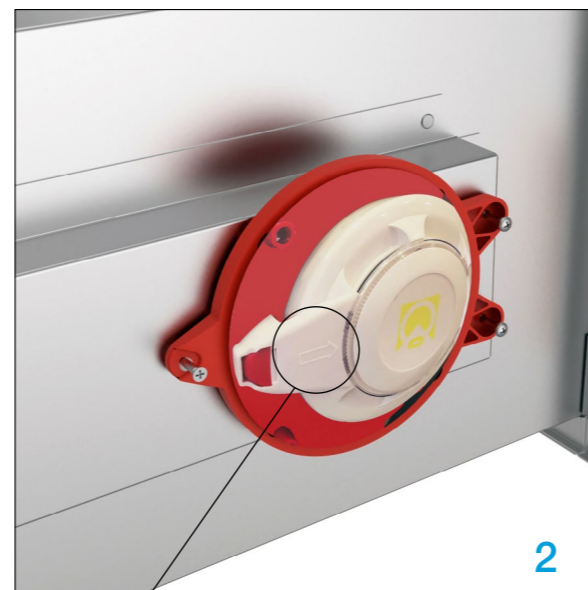
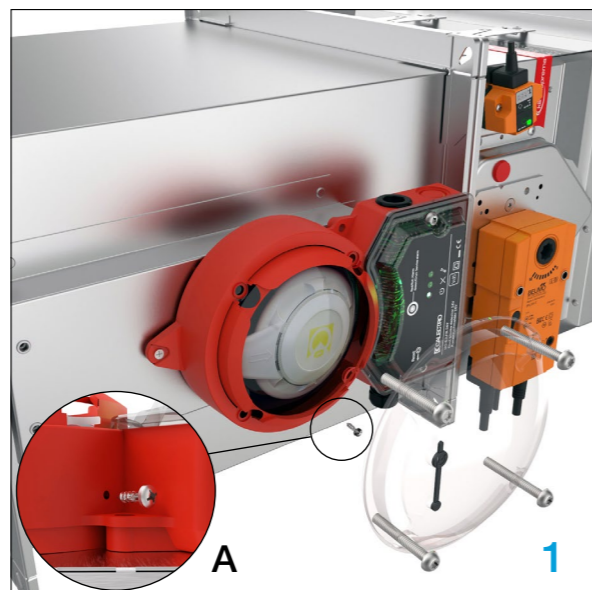

STANDARD AIR FLOW DIRECTION →

← ROTATED AIR FLOW DIRECTION

## UPGRADE TO END CONTACTS (R25 → R25-S)

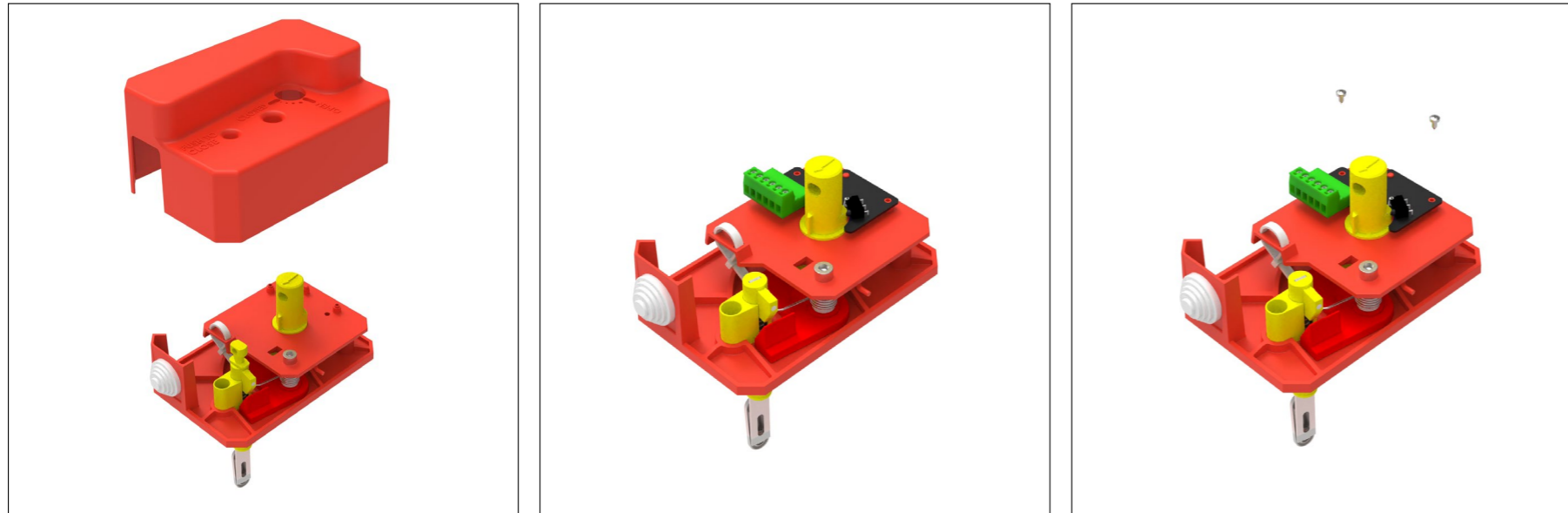

## UPGRADE TO END CONTACTS (R40 → R40-S)

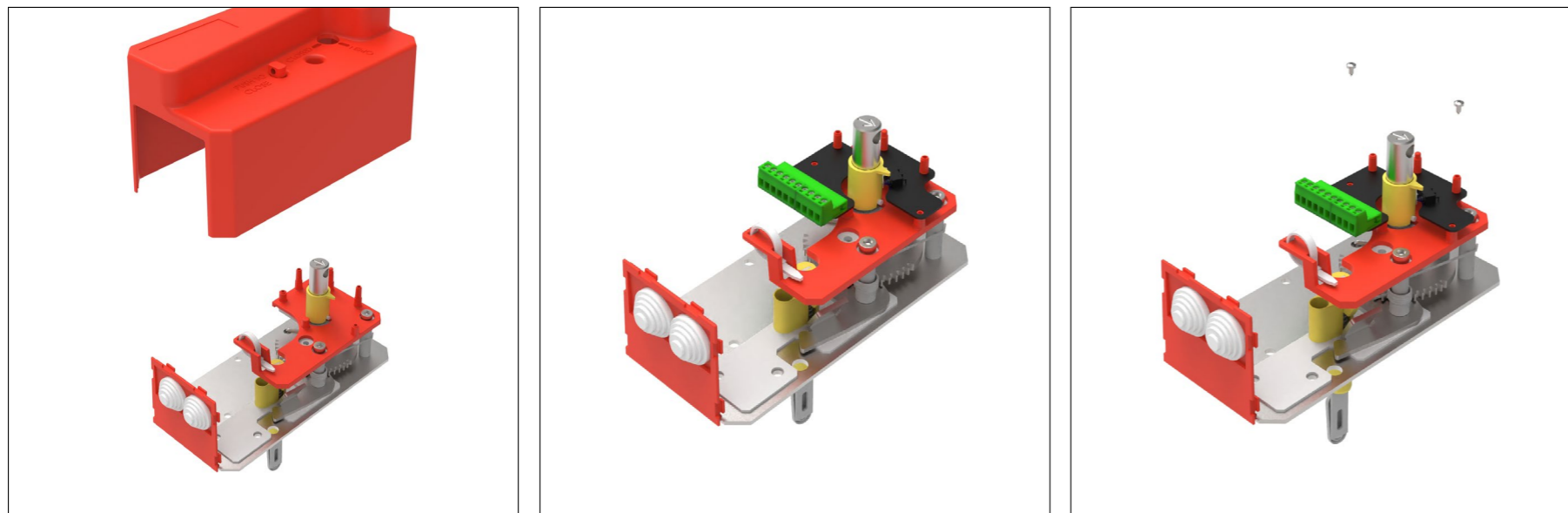

- ▼ [PRODUCT OVERVIEW](#)
- ▼ [DIMENSIONS](#)
- ▼ [INSTALLATIONS](#)
- ▼ [ACTUATORS](#)
- ▼ [ACCESSORIES](#)
- ▼ [REPLACEMENTS](#)
- ▼ [MAINTENANCE AND OPERATION](#)

↻ REPLACEMENTS

FIRE DAMPER - FD

1. Locate hex screw, unscrew it and remove the cover.
2. Insert CEE (R25)/CEDC (R40) board in the appropriate place.
3. Screw the board to the plate. Put the cover back in place!

## UPGRADE FROM MANUAL (R40-S) TO EMS

Before upgrade R40 to EMS, it is necessary to install kit for end contacts (FD-A-R40S-KIT).

Before upgrade R25/RS25-S to EMS, it is necessary to install R40 mechanism (FD-A-R40) and kit for end contacts (FD-A-R40S-KIT).

To upgrade to EMS you need to use the EMS kit!

**Service work may only be performed by authorized persons!**

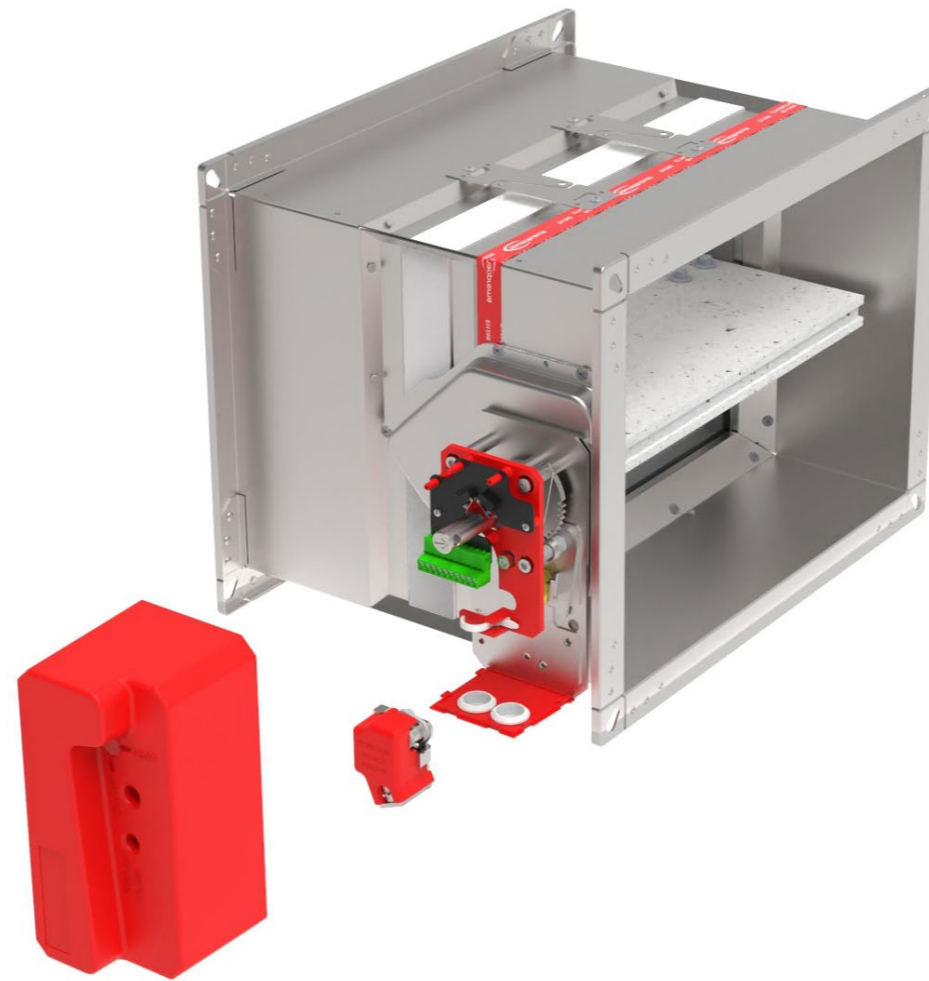

- ▼ [PRODUCT OVERVIEW](#)
- ▼ [DIMENSIONS](#)
- ▼ [INSTALLATIONS](#)
- ▼ [ACTUATORS](#)
- ▼ [ACCESSORIES](#)
- ▼ [REPLACEMENTS](#)
- ▼ [MAINTENANCE AND OPERATION](#)

### REPLACEMENTS

### FIRE DAMPER - FD

1. Locate hex screw. Unscrew it and remove the cover.

2. Insert the EMS on the custom plate.

3. Screw the EMS to the plate and connect the 2-pin connector into the appropriate socket on the CEDC board.

4. Put the cover back in place.

**Test the operation of the damper blade!**

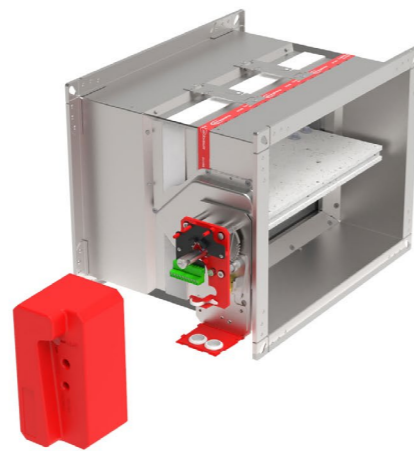

1

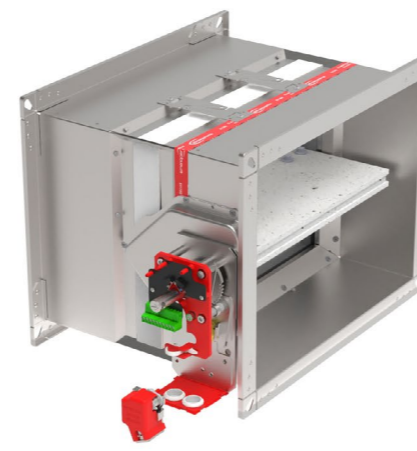

2

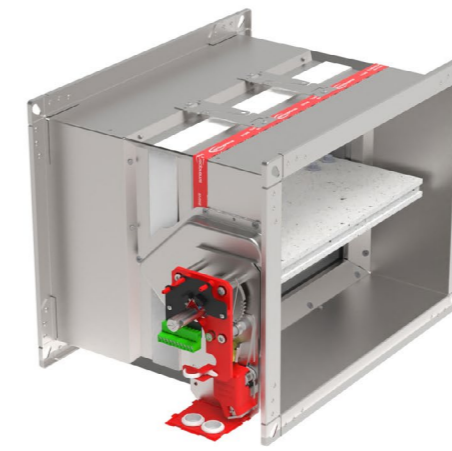

3

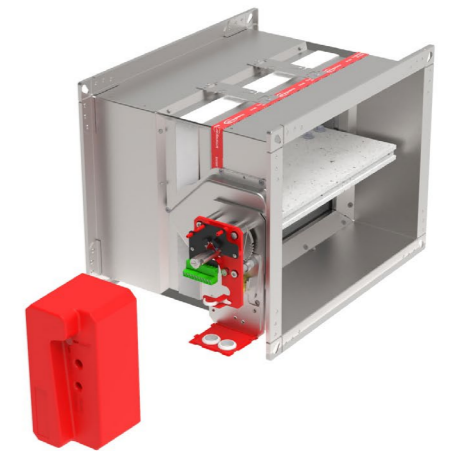

4

## REPLACEMENT OF THERMAL FUSE (R25)



- ▼ [PRODUCT OVERVIEW](#)
- ▼ [DIMENSIONS](#)
- ▼ [INSTALLATIONS](#)
- ▼ [ACTUATORS](#)
- ▼ [ACCESSORIES](#)
- ▼ [REPLACEMENTS](#)
- ▼ [MAINTENANCE AND OPERATION](#)

1. Find the hex screw located on the cover. Unscrew and remove the screw and the cover.

2. Find the hex screw on the thermal fuse and unscrew it.

3. Remove the old thermal fuse. Insert a new thermal fuse and screw it back on.

4. Put the cover back in place.

**Test the operation of the damper blade!**

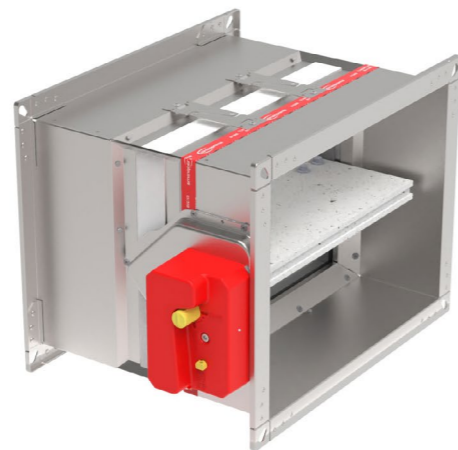

1



2

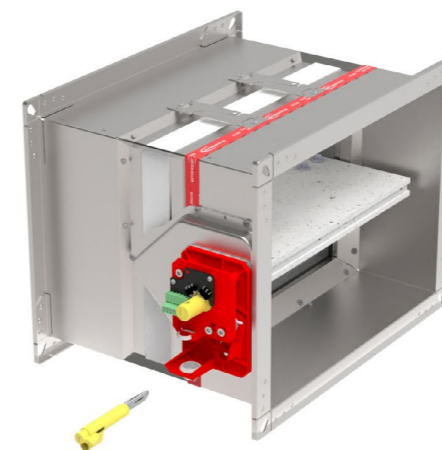

3



4

# REPLACEMENT OF THERMAL FUSE (R40)

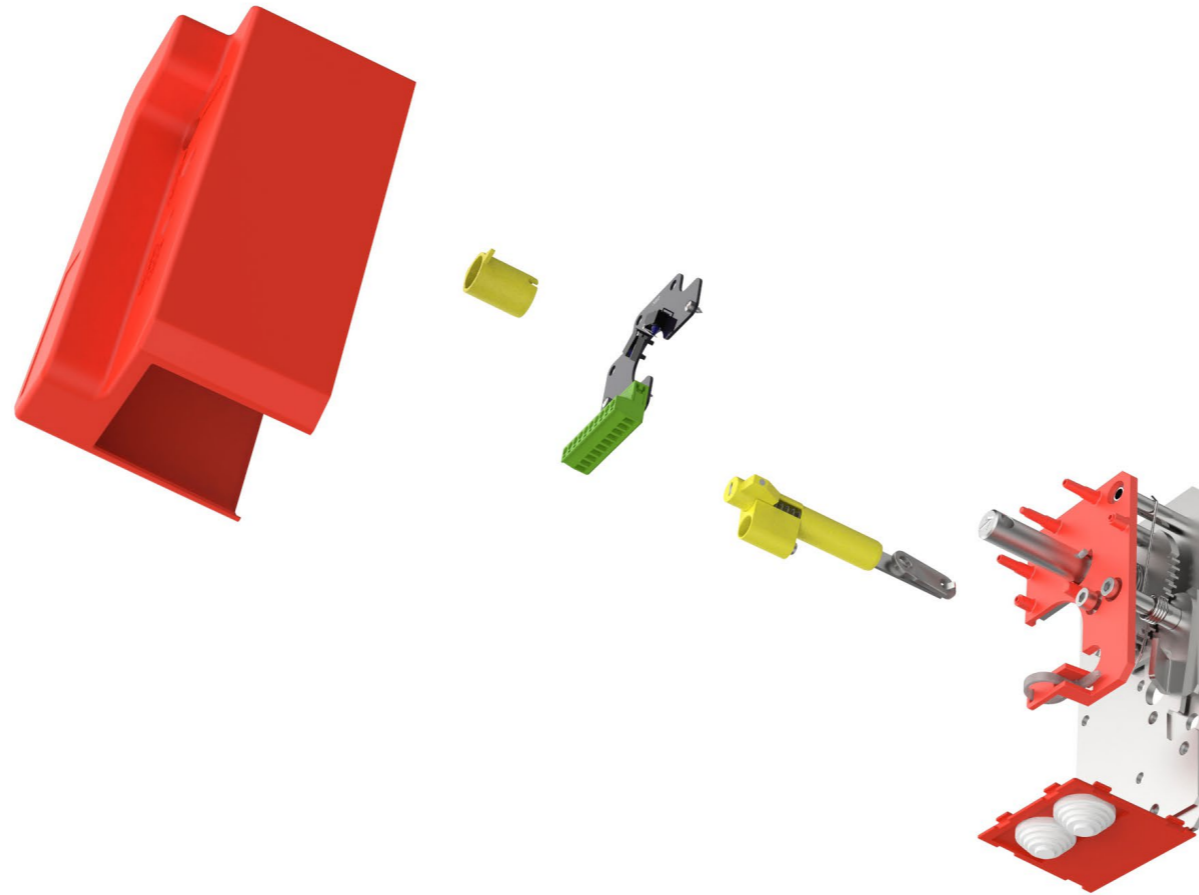

- ▼ [PRODUCT OVERVIEW](#)
- ▼ [DIMENSIONS](#)
- ▼ [INSTALLATIONS](#)
- ▼ [ACTUATORS](#)
- ▼ [ACCESSORIES](#)
- ▼ [REPLACEMENTS](#)
- ▼ [MAINTENANCE AND OPERATION](#)

1. Find the hex screw located on the cover, unscrew and remove the screw and the cover.

2. Remove the position indicator sleeve.

3. Locate the 3 hex screws. Unscrew them. Remove the CEDC board (if applicable).

4. Locate the screw on the thermal fuse. Unscrew it. Remove the old thermal fuse. Insert a new thermal fuse. Put the CEDC board and the cover back in place.

**Test the operation of the damper blade!**

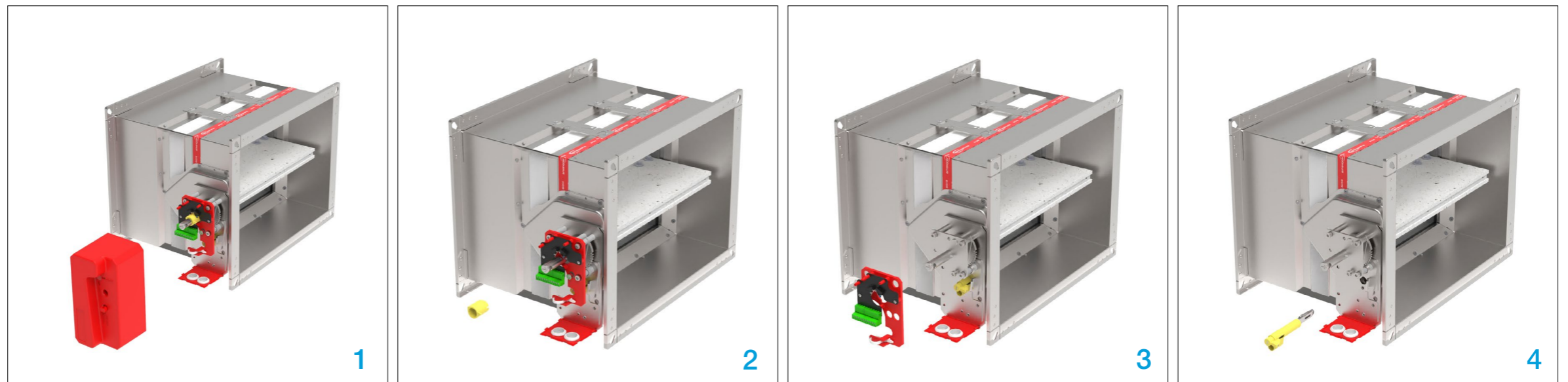

# UPGRADE TO ELECTRIC ACTUATOR Manual R25 <-> Belimo

100x200 to 800x600

The blade must be closed before replacement the mechanism.

**Service work may only be performed by authorized persons!**

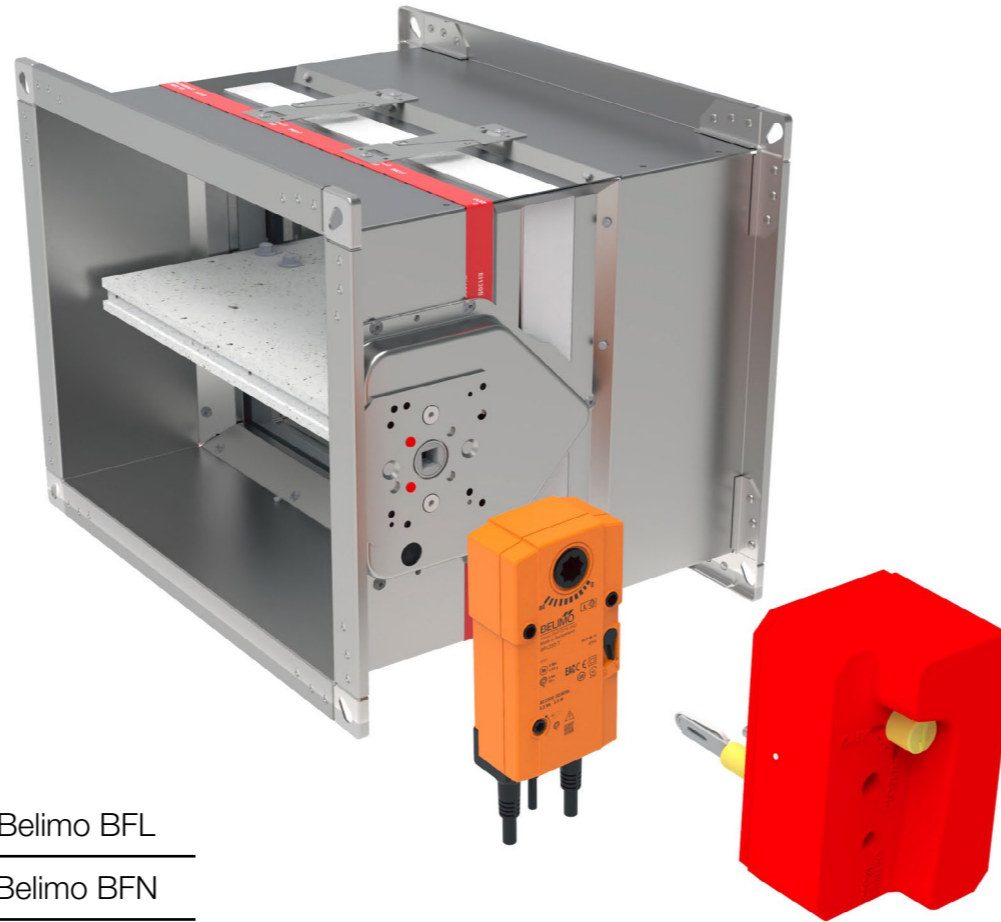

FD-A-KTA	Belimo BFL
FD-A-KTB	Belimo BFN
FD-A-KTC	Belimo BF

- ▼ [PRODUCT OVERVIEW](#)
- ▼ [DIMENSIONS](#)
- ▼ [INSTALLATIONS](#)
- ▼ [ACTUATORS](#)
- ▼ [ACCESSORIES](#)
- ▼ [REPLACEMENTS](#)
- ▼ [MAINTENANCE AND OPERATION](#)

## REPLACEMENTS

## FIRE DAMPER - FD

**NOTE:** Use kit according to table (upgrade to electric actuator)!

\* Before replacing the mechanism, the damper blade must be closed.

\* Find the screw and remove the cover!

1. Find the 2 hex screws located on the board of mechanism, unscrew them and remove manual mechanism.

2. Find the 2 hex screws located on the mechanism (E), unscrew them and replace the manual mechanism plate (A) with BE transition plate (B) provided in the kit.

**NOTE:** Pay attention to the position of indication cut on the BE transition plate.

3. Insert the rubber plug into the opening for the thermal fuse. Install square shaft into the hole, put Belimo actuator on the shaft and fasten the actuator with screws (2 hexagon screws M6x55).

**\*Check the rotation direction of the actuator!** (Clockwise actuation, R mark on the actuator)

4. Drill hole (ø16 mm) for the fuse of Belimo mechanism and fix it with self-tapping screws.

**NOTE:** Install the thermal fuse in a place where it will not interfere with the operation of the damper blade !

**Test the operation of the damper blade!**

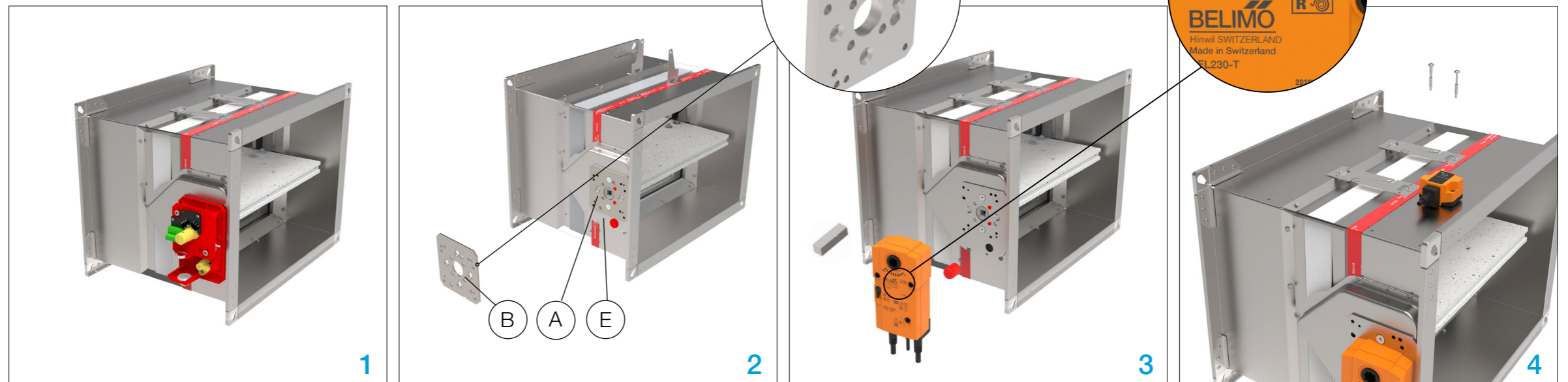

# UPGRADE TO ELECTRIC ACTUATOR Manual R40 <-> Belimo

800x600 to 1500x800

The blade must be closed before replacement the mechanism.

Service work may only be performed by authorized persons!

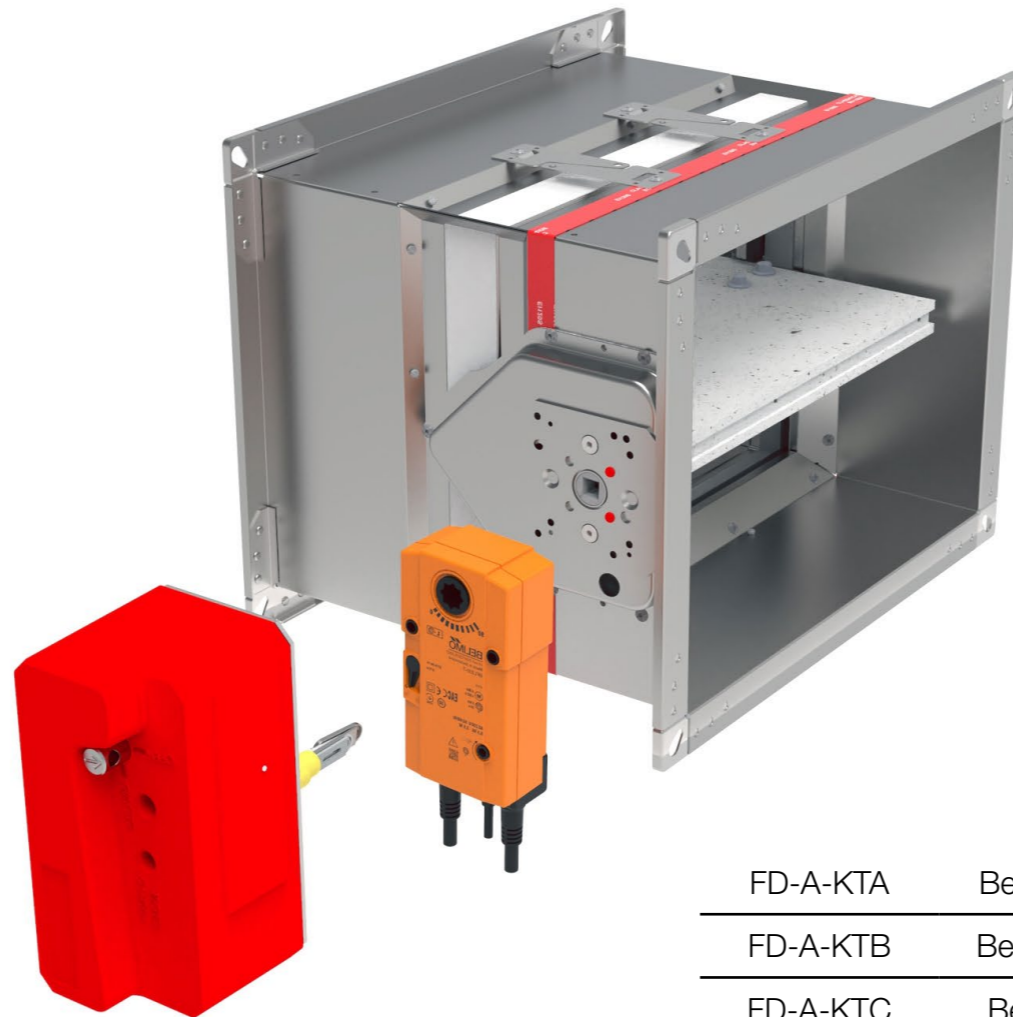

- ▼ [PRODUCT OVERVIEW](#)
- ▼ [DIMENSIONS](#)
- ▼ [INSTALLATIONS](#)
- ▼ [ACTUATORS](#)
- ▼ [ACCESSORIES](#)
- ▼ [REPLACEMENTS](#)
- ▼ [MAINTENANCE AND OPERATION](#)

## REPLACEMENTS

## FIRE DAMPER - FD

**NOTE:** Use kit according to table (upgrade to electric actuator)!

\*Before replacing the mechanism, the damper blade must be closed.

\* Find the screw and remove the cover!

1. Find the 3 hex screws located on the board of mechanism, unscrew them and remove manual mechanism.

2. Find the 2 hex screws located on the mechanism (E), unscrew them and replace the manual mechanism plate (A) with BE transition plate (B) provided in the kit.

**NOTE:** Pay attention to the position of indication cut on the BE transition plate.

3. Insert the rubber plug into the opening for the thermal fuse. Install square shaft into the hole, put Belimo actuator on the shaft and fasten the actuator with screws (2 hexagon screws M6x55).

\***Check the rotation direction of the actuator!** (Clockwise actuation, R mark on the actuator)

4. Drill hole (ø16 mm) for the fuse of Belimo mechanism and fix it with self-tapping screws.

**NOTE:** Install the thermal fuse in a place where it will not interfere with the operation of the damper blade! **Test the operation of the damper blade!**

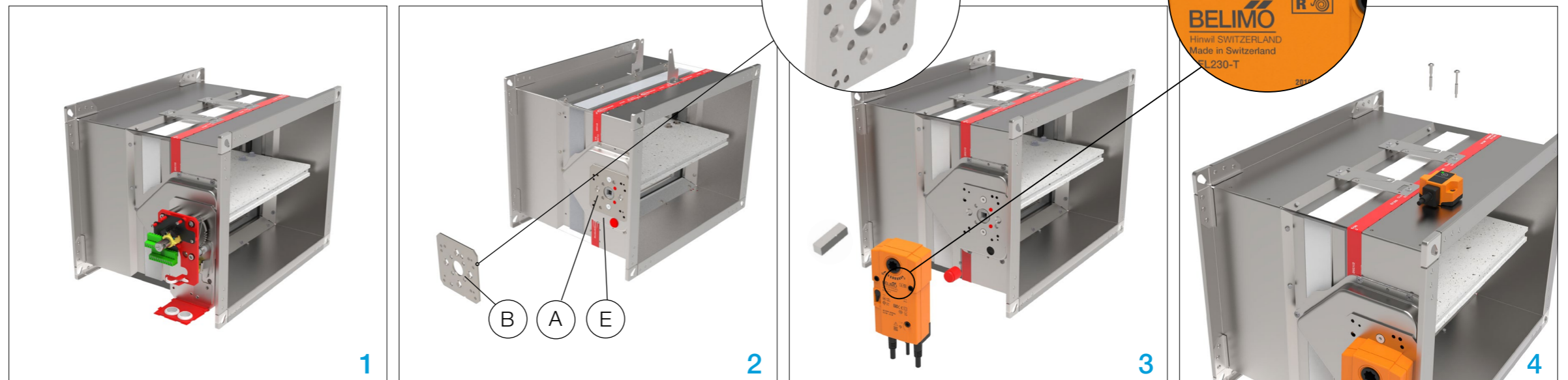

# HOW TO ROTATE ELECTRIC ACTUATOR (Belimo)

100x200 to 1500x800

The blade must be closed before replacement the mechanism.

ERK Kit (FD-A-ERK)

- transition plate
- rectangular shaft
- 2x screws M6x30



- ▼ [PRODUCT OVERVIEW](#)
- ▼ [DIMENSIONS](#)
- ▼ [INSTALLATIONS](#)
- ▼ [ACTUATORS](#)
- ▼ [ACCESSORIES](#)
- ▼ [REPLACEMENTS](#)
- ▼ [MAINTENANCE AND OPERATION](#)

## REPLACEMENTS

## FIRE DAMPER - FD

1) Locate the 2 hex screws, unscrew and remove actuator.

2) Remove FA transition plate and rectangular shaft.

3) Insert new transition plate and rectangular shaft from ERK kit.

### NOTE

**A** Pay attention to the position of the indicator cut!  
**B** Pay attention to the indicator cut, insert the ERK rectangular shaft that a smaller portion of the shaft enters ERK transition plate!

4) Fix the transition plate to the transition board and install the Belimo actuator.

**Test the operation of the damper blade!**

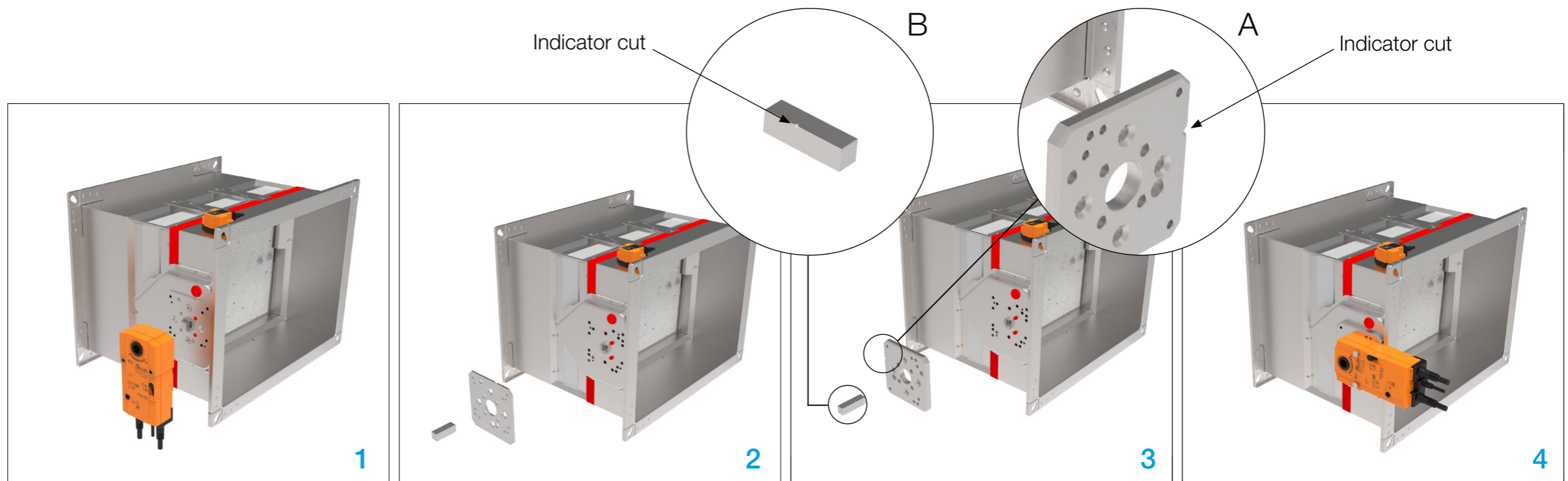



- ▼ [PRODUCT OVERVIEW](#)
- ▼ [DIMENSIONS](#)
- ▼ [INSTALLATIONS](#)
- ▼ [ACTUATORS](#)
- ▼ [ACCESSORIES](#)
- ▼ [REPLACEMENTS](#)
- ▼ [MAINTENANCE AND OPERATION](#)



## TRANSPORT

After arrival, check the fire damper for transport damage and shortcomings. In case of any damage or shortcomings, immediately contact your supplier.

## STORAGE

If the damper is not installed immediately:

- Remove any wrapping.
- Protect fire damper from dust and contamination.
- Do not expose the fire damper to the effects of weather - store fire damper in a dry place.
- Do not store the unit below -20 °C or above 50 °C.

**Please properly dispose of packaging material!**

## MAINTENANCE AND OPERATION

Fire dampers are designed with fully enclosed drive mechanism outside of the duct and as such do not require cleaning and regular maintenance.

However, activation mechanism should be inspected for proper operation on regular basis.

- Provide at least one annual check of the damper
- After each intervention, provide a systematic cleaning of dust and especially the solenoid and its movable plate
- Check the if the electrical terminals are tightened
- Cleaning instruction: clean with a sponge, with water or a mild detergent
- Disinfection instruction: spray disinfectant (disinfectant may contain alcohol which is flammable, take precaution to avoid ignition)

It is not permitted to alter the dampers in any way nor perform any changes to their structure (except for the service procedures described in this manual) without the manufacturer's consent. Provide at least one annual check of the damper. The functional test must be carried out in compliance with the basic maintenance principles of the European norms EN 13306, EN 15423 and EN15650.

## COMMISSIONING

- 1) Carefully unpack FD fire damper - be careful of sharp edges and do not use excessive force for unpacking
- 2) Inspect the fire damper - check the fire damper for damage
- 3) Installation of the fire damper - according to the installation instructions ([page 16.](#))
- 4) Before commissioning: check the fire damper functions

## FUNCTIONS

- 1) Release mechanism:  
Damper blade can be closed and opened manually
- 2) EMS:  
Signal testing - the damper blade must close
- 3) Electric actuator:  
Signal testing - the damper blade must close/open
- 4) Thermal fuse:  
By a button - the damper blade must be closed by pressing the button

# FIRE DAMPER TESTING

## MANUAL ACTUATORS/ SOLENOID ACTUATOR

1. Close the damper blade by pushing the thermic actuator through the hole on the casing.

2. Open the damper blade by inserting the metal rod (i.e. screwdriver, hex wrench) max. 7 mm in diameter, into the yellow/ silver part and rotate the arrow to the open position.



## ELECTRIC ACTUATOR

1. Test the operation of the damper blade by pushing the test button.

2. Opening the damper blade:  
Insert the handle provided with the Belimo actuator into the hole. Rotate it as shown on the actuator.



- ▼ [PRODUCT OVERVIEW](#)
- ▼ [DIMENSIONS](#)
- ▼ [INSTALLATIONS](#)
- ▼ [ACTUATORS](#)
- ▼ [ACCESSORIES](#)
- ▼ [REPLACEMENTS](#)
- ▼ [MAINTENANCE AND OPERATION](#)



**FIRE DAMPER - FD**



## FIRE DAMPER - FD

---

 Joseph Wilson Industrial Estate, Whitstable, CT5  
 3DU UK+44 (0) 1634  
 [actionair@swegon.com](mailto:actionair@swegon.com)  
 [www.swegon.com/uk/](http://www.swegon.com/uk/)

---